

AD 2 AERODROMES

RJAA AD 2.1 AERODROME LOCATION INDICATOR AND NAME

RJAA - NARITA INTL

RJAA AD 2.2 AERODROME GEOGRAPHICAL AND ADMINISTRATIVE DATA

1	ARP coordinates and site at AD	354555N 1402308E 178° / 0.5km from NARITA control tower 123° / 1.9km from RWY 16R THR 349° / 2.5km from RWY 34L THR 171° / 4.5km from RWY 16L THR 194° / 2.4km from RWY 34R THR
2	Direction and distance from (city)	57.5km (31nm) E (BRG. 80° GEO.) from Tokyo Station (JR) 7.0km (3.8nm) ESE (BRG. 100° GEO.) from Narita Station (JR)
3	Elevation/ Reference temperature	135ft / 31°C (2018-2022)
4	Geoid undulation at AD ELEV PSN	116ft
5	MAG VAR/ Annual change	8°W (2023) / 3' W
6	AD Administration, address, telephone, telefax, telex, AFS, e-mail and/or Web-site addresses	Narita International Airport Corporation (NAA) Narita INTL Airport Corporation:P.O.BOX 80 Narita INTL Airport, Narita-shi , Chiba Pref Japan 282-8601 AFS: RJAAYDYX Tel: 0476-34-5635 Fax: 0476-30-1577
7	Types of traffic permitted (IFR/VFR)	IFR/VFR
8	Remarks	Narita Airport Office (Civil Aviation Bureau) Airport Administration Building , Narita INTL Airport , Narita-shi , Chiba Pref Japan 282-8601 Tel: 0476-32-0909 (2330-0815UTC SUN-THU(EXC HOL))

RJAA AD 2.3 OPERATIONAL HOURS

1	AD Administration	H24. (See RJAA AD 2.20)
2	Customs and immigration	Customs: 2100-1400 Immigration: 2030-1500
3	Health and sanitation	Quarantine(human): 2100-1530 Quarantine(animal, plant): 2100-1500
4	AIS Briefing Office	Nil
5	ATS Reporting Office(ARO)	Nil
6	MET Briefing Office	H24
7	ATS	H24
8	Fuelling	H24
9	Handling	H24
10	Security	H24
11	De-icing	H24
12	Remarks	Nil

RJAA AD 2.4 HANDLING SERVICES AND FACILITIES

1	Cargo-handling facilities	All the modern institutions that deal with the weight thing to a Boeing 747 type freighter.
2	Fuel/ oil types	Fuel grades: Jet A-1. Oil grades: All turbine grades.
3	Fuelling facilities/ capacity	Hydrant refuelling and fuel truck refuelling.
4	De-icing facilities	By arrangement with handling agent.
5	Hangar space for visiting aircraft	By arrangement with operating airlines.
6	Repair facilities for visiting aircraft	By arrangement with operating airlines.
7	Remarks	Nil

RJAA AD 2.5 PASSENGER FACILITIES

1	Hotels	Hotels around the airport.
2	Restaurants	At Airport
3	Transportation	Railways, buses and taxis.
4	Medical facilities	First aid treatment, ambulance; hospitals in Narita city 10km .
5	Bank and Post Office	At Airport
6	Tourist Office	At Airport
7	Remarks	Nil

RJAA AD 2.6 RESCUE AND FIRE FIGHTING SERVICES

1	AD category for fire fighting	CAT 10
2	Rescue equipment	Chemical fire fighting truck x 6 Water-supply truck x 3, Emergency medical equipments conveyance truck, Small sized emergency medical equipments conveyance truck, Destructive wrecking truck Form tank Ambulance x 2 Mobile command post
3	Capability for removal of disabled aircraft	B747-400 or B777-300ER JAL STATION CONTROLLER (0476-34-3401)
4	Remarks	Nil

RJAA AD 2.7 SEASONAL AVAILABILITY-CLEARING

1	Types of clearing equipment	Snow Removal Equipment : snow plough x 14, snow sweeper x 7 , snow blower x 4
2	Clearance priorities	Seasonal availability: All seasons. In general, the following priorities will be established for the clearing of the movement areas: RWY 16R/34L, TWY associated with RWY 16R/34L, Apron.
3	Remarks	TWY/APN to measure the coefficient of friction: TWY: A, A1, A3, A7, A10, W (W5NGWY - SPOT 232), Q6 (SPOT 11 - Q5), Q5, W5, R (SPOT 24 - SPOT 42), T (SPOT 44 - T8), P (T10 - C), M (SPOT 801 - SPOT 808), K (A - B8), C (P - B), P2 (C - P3), P3, E2, B, B1, B2, B7, B8 (See attached chart) SPOT: ALL

RJAA AD 2.8 APRONS, TAXIWAYS AND CHECK LOCATIONS DATA

1	Apron surface and strength	Surface : Concrete Strength : PCN 140/R/C/X/T except PCN 65/R/B/X/T NR174, 175, 181, 182, 183, 610A, 610B, 610C, 610D, 611, 612, 613, 614
2	Taxiway width, surface and strength	Width: 30m except 25m on TWY C between B and P2-GWY, TWY K between S4 and E7, TWY C between S1 and S3, TWY T4 between S and S4-GWY, TWY T between S7-GWY and T10, TWY S7, TWY B6, A3, A4, A5, A6, A7 and A8, TWY E8, U8-GWY TWY L between F5 and K, U5-GWY 23m on TWY K between B8 and E2, TWY P1 between C and P1-GWY Surface: Asphalt except Concrete on TWY A between A1 and W3-GWY, A9 and A10 Concrete on TWY B between B1 and B4 Strength : PCN 140/F/C/X/T except PCN 140/R/C/X/T on TWY A between A1 and W3-GWY, A9 and A10 PCN 129/F/C/W/T on TWY B between B4 and K, TWY K between B and E5 PCN 129/R/C/X/T on TWY B between B1 and B4 PCN 74/F/C/X/T on TWY P1 between C and P1-GWY
3	ACL and elevation	Location : Any portion on the apron areas available Elevation : Terminal apron-40m Maintenance apron-41m
4	VOR checkpoints	Not available

5	INS checkpoints	<p>Spot NR</p> <p>11 354600.51N 1402304.94E 12 354601.98N 1402304.50E 14 354602.87N 1402303.03E 15 354602.58N 1402301.34E 16 354601.31N 1402300.44E 17 354559.91N 1402300.98E 18 354558.99N 1402302.42E</p> <p>21 354553.88N 1402258.58E 22 354554.25N 1402256.42E 23 354553.18N 1402255.14E 24 354551.94N 1402255.13E 25 354550.50N 1402256.92E 26 354547.90N 1402258.80E 27 354545.30N 1402300.67E</p> <p>31 354543.18N 1402302.14E 32 354545.21N 1402305.37E 33 354541.08N 1402303.65E 34 354542.15N 1402306.79E 35 354538.99N 1402305.17E 36 354540.06N 1402308.31E 37 354536.37N 1402307.18E 38 354537.86N 1402309.62E 41 354534.12N 1402308.77E 42 354531.99N 1402310.21E 43 354530.67N 1402311.50E 44 354531.57N 1402313.00E 45 354533.14N 1402313.60E 46 354535.20N 1402315.12E 47 354536.69N 1402313.06E</p> <p>51 354545.48N 1402315.31E 52 354543.69N 1402316.61E 53 354542.83N 1402318.28E 54 354543.67N 1402319.83E 54R 354543.33N 1402319.81E 54L 354541.97N 1402319.82E 55 354545.26N 1402320.42E 56 354547.48N 1402321.65E 57A 354550.23N 1402323.17E 57B 354552.40N 1402324.81E 58A 354555.32N 1402326.27E 58B 354557.54N 1402327.50E</p> <p>61 354622.57N 1402323.82E 61R 354623.13N 1402324.18E 62 354620.48N 1402325.34E 62R 354621.07N 1402325.62E 63 354618.38N 1402326.85E 63R 354618.85N 1402327.13E 64 354616.28N 1402328.37E 64R 354616.70N 1402328.65E 65 354614.19N 1402329.88E 66 354612.33N 1402330.90E 66R 354612.54N 1402331.19E 67 354609.61N 1402332.49E 67L 354608.97N 1402333.31E 67R 354610.33N 1402331.70E 68 354606.86N 1402332.48E 68L 354605.96N 1402332.79E 68R 354607.08N 1402332.63E</p> <p>71 354629.98N 1402318.47E 71R 354630.41N 1402318.74E 72 354632.08N 1402316.95E 72R 354632.55N 1402317.25E 73 354634.18N 1402315.44E 73R 354634.76N 1402315.68E 74 354636.28N 1402313.92E 74R 354636.87N 1402314.20E 75 354638.37N 1402312.41E 76 354642.28N 1402310.33E 77 354645.24N 1402308.20E</p>	<p>81 354634.76N 1402332.94E 82 354633.96N 1402329.30E 83 354636.86N 1402331.43E 84 354635.62N 1402328.20E 85 354638.96N 1402329.91E 86 354638.58N 1402326.06E 87 354640.33N 1402328.81E 88 354639.73N 1402327.38E</p> <p>91 354632.67N 1402334.46E 92 354628.37N 1402333.34E 93 354630.57N 1402335.97E 94 354626.78N 1402334.59E 95 354628.47N 1402337.49E 96 354623.75N 1402336.68E 97 354626.38N 1402339.00E 98 354624.20N 1402338.60E 99 354625.22N 1402339.69E</p> <p>100A 354645.43N 1402321.52E 100B 354644.64N 1402319.14E 100C 354643.68N 1402317.77E 100E 354646.68N 1402318.03E 100F 354647.37N 1402319.23E 101 354645.73N 1402321.30E 102 354645.35N 1402320.33E 103 354644.15N 1402317.85E 104 354645.26N 1402317.05E 105 354646.81N 1402319.28E</p> <p>150 354647.95N 1402307.52E 151 354645.22N 1402308.15E 152 354644.59N 1402309.28E 153 354643.30N 1402310.04E 154 354642.08N 1402310.92E 155 354640.94N 1402311.92E</p> <p>161 354649.37N 1402310.14E 162 354650.43N 1402311.38E 163 354651.50N 1402312.61E 164 354652.57N 1402313.85E</p> <p>174 354653.66N 1402311.85E 175 354654.69N 1402313.04E</p> <p>181 354659.34N 1402309.60E 182 354658.32N 1402308.41E 183 354656.62N 1402307.25E</p> <p>191 354532.06N 1402324.78E 191L 354532.99N 1402324.35E 191R 354531.70N 1402323.63E 192 354529.48N 1402323.35E 192L 354530.42N 1402322.92E 192R 354529.13N 1402322.21E</p> <p>201 354611.92N 1402301.14E 202 354610.54N 1402258.20E 203 354609.00N 1402255.05E 204 354607.79N 1402252.55E 205 354605.92N 1402250.30E 206 354607.75N 1402249.74E 207 354610.13N 1402248.02E 208 354612.39N 1402246.38E 209 354614.87N 1402244.60E 210 354617.53N 1402242.68E 211 354620.61N 1402240.45E 212 354623.01N 1402238.72E</p>
---	-----------------	--	---

5	INS checkpoints	<p>221 354603.21N 1402242.92E 222 354605.04N 1402241.28E 223 354607.23N 1402239.83E 224 354609.40N 1402238.26E 225 354611.57N 1402236.69E 226 354614.07N 1402234.89E</p> <p>231 354620.39N 1402231.23E 231A 354619.92N 1402231.56E 231B 354621.61N 1402230.34E 231C 354623.29N 1402229.12E 232 354622.90N 1402229.41E</p> <p>401 354620.70N 1402346.98E 402 354617.95N 1402345.45E 402L 354619.19N 1402346.16E 402R 354618.33N 1402344.85E 403 354615.19N 1402343.93E 403L 354616.53N 1402344.65E 403R 354615.58N 1402343.33E</p> <p>410 354604.27N 1402330.96E 410L 354603.35N 1402331.32E 410R 354604.99N 1402331.35E 411 354601.65N 1402329.51E 411L 354600.73N 1402329.87E 411R 354602.44N 1402329.71E 412 354559.64N 1402328.93E</p> <p>421 354543.01N 1402334.72E 421L 354543.94N 1402334.71E 421R 354543.10N 1402334.01E 422 354545.50N 1402336.06E 422L 354546.41N 1402336.09E 422R 354545.58N 1402335.40E 423 354548.13N 1402337.52E 423L 354549.05N 1402337.55E 423R 354548.21N 1402336.85E 424 354550.65N 1402338.91E 424L 354551.56N 1402338.94E 424R 354550.72N 1402338.25E 425 354553.13N 1402340.29E 425L 354554.04N 1402340.32E 425R 354553.21N 1402339.62E 426 354555.62N 1402341.66E 426L 354556.53N 1402341.70E 426R 354555.69N 1402341.00E 427 354558.31N 1402343.21E 427L 354559.25N 1402342.76E 427R 354557.64N 1402342.91E 428 354600.90N 1402344.64E 428L 354601.84N 1402344.19E 428R 354600.23N 1402344.35E 429 354603.16N 1402344.82E 430 354604.46N 1402345.54E 431 354605.60N 1402346.66E</p> <p>441 354638.90N 1402354.49E 441L 354639.25N 1402353.49E 441R 354638.01N 1402354.34E 442 354636.46N 1402356.26E 442L 354636.80N 1402355.26E 442R 354635.56N 1402356.11E 443 354634.01N 1402358.02E 443L 354634.56N 1402357.45E 443R 354633.29N 1402358.23E 444 354631.54N 1402359.83E 444L 354631.79N 1402358.62E 444R 354630.56N 1402359.50E 445 354629.10N 1402401.59E</p>	<p>445L 354629.74N 1402401.21E 445R 354628.51N 1402402.09E 446 354626.22N 1402403.68E 446L 354626.46N 1402402.47E 446R 354625.24N 1402403.35E 447 354623.77N 1402405.42E 447L 354624.23N 1402404.65E 447R 354623.14N 1402405.82E 448 354621.33N 1402407.19E 448L 354621.57N 1402405.98E 448R 354620.35N 1402406.87E 449 354618.88N 1402408.96E 449L 354619.47N 1402408.48E 449R 354618.25N 1402409.36E 450 354616.43N 1402410.72E 450L 354616.68N 1402409.52E 450R 354615.46N 1402410.40E</p> <p>501 354517.97N 1402344.99E 502 354520.07N 1402343.47E 503 354522.16N 1402341.96E 504 354524.26N 1402340.44E 505 354526.50N 1402338.83E 505L 354526.47N 1402337.57E 505R 354525.35N 1402338.38E</p> <p>508 354522.26N 1402329.96E 509 354521.21N 1402329.37E 510 354518.99N 1402328.15E 511 354511.91N 1402324.22E 512 354511.22N 1402325.08E</p> <p>600A 354515.68N 1402335.97E 600B 354513.70N 1402335.68E 600C 354513.58N 1402334.11E 600D 354513.17N 1402335.09E 600E 354513.01N 1402333.72E 600F 354512.26N 1402332.52E 600G 354510.84N 1402335.96E</p> <p>600J 354510.34N 1402334.68E 600K 354509.81N 1402334.43E 600L 354509.07N 1402334.97E 600M 354511.49N 1402340.47E 600N 354512.78N 1402339.61E 600P 354514.09N 1402338.67E 600Q 354514.30N 1402337.23E 600R 354515.19N 1402336.50E 600S 354516.56N 1402336.42E 600T 354517.56N 1402335.69E 600U 354516.97N 1402335.87E 601 354516.50N 1402334.97E 602 354510.78N 1402338.42E 603 354510.28N 1402335.33E 604 354514.40N 1402335.57E 605 354514.57N 1402337.38E 610A 354512.45N 1402350.73E 610B 354511.55N 1402351.70E 610C 354510.56N 1402352.43E 610D 354509.59N 1402353.14E 611 354513.11N 1402349.10E 612 354512.35N 1402350.69E 613 354511.25N 1402351.81E 614 354510.03N 1402352.68E</p>
---	-----------------	--	---



5	INS checkpoints	701 354506.04N 1402329.49E 702 354503.83N 1402329.27E 703 354501.63N 1402330.86E 704 354459.44N 1402332.44E 705 354457.24N 1402334.03E 706 354455.05N 1402335.61E 707 354452.85N 1402337.20E 708 354447.18N 1402341.29E 709 354444.88N 1402342.96E 710 354442.57N 1402344.63E	801 354500.69N 1402328.75E 802 354458.41N 1402330.40E 803 354456.12N 1402332.05E 804 354454.00N 1402333.59E 805 354451.87N 1402335.12E 806 354446.19N 1402339.22E 807 354443.88N 1402340.89E 808 354441.58N 1402342.56E 902 354436.71N 1402351.15E 903 354435.35N 1402348.32E 904 354434.00N 1402345.49E 905 354433.63N 1402340.92E
6	Remarks	Nil	

RJAA AD 2.9 SURFACE MOVEMENT GUIDANCE AND CONTROL SYSTEM AND MARKINGS

1	Use of aircraft stand ID signs, TWY guide lines and Visual docking/ parking guidance system of aircraft stands	ACFT stand ID signs : NR11,12,14-18, 21-27, 31-38, 41-47, 51-56, 57A, 57B, 58A, 58B, 61-68, 71-77, 81-88, 91-99, 151-155, 161-164, 174, 175, 201-212, 231, 232 ACFT stand taxilane : See AD2.24 Aerodrome Ground Movement Chart Visual docking guidance system : See attachment
2	RWY and TWY markings and LGT	RWY 16R/34L, 16L/34R: (Marking) RWY designation, RWY CL, RWY THR, Aiming point, TDZ, RWY middle point, RWY side stripe (LGT) RCLL , REDL, RTHL , RENL , RTZL , WBAR TWY: (Marking) TWY CL, RWY HLDG PSN, Mandatory instruction, TWY side stripe, Intermediate HLDG PSN(See attached chart), SFC painted location sign (See attached chart), SFC painted direction sign (See attached chart) (LGT) TWY edge LGT, TWY CL LGT, Taxiing guidance signs, Stop bar LGT (A1 - A10, B1 - B9) , RWY guard LGT (A1 - A10, B1 - B9), Intermediate HLDG PSN LGT (See attached chart)
3	Stop bars	Stop Bar Light Operations: 1) Stop bar lights are installed at each runway-holding position associated with RWY 16R/34L and 16L/34R. 2) Stop bar lights will be operated when the visibility or the lowest RVR of RWY 16R/34L and 16L/34R is at or less than 600m(1968ft) 3) Stop bar lights on TWY A1, A2, B8 and B9 are controlled individually by ATC. 4) Stop bar lights on TWY A3 - A10, B1 - B7 are not controlled individually by ATC. 5) During the period stop bar lights are operated, TWY A3 - A10, B1 - B7 are not available for the departing aircraft.
4	Remarks	Apron: (Marking) ACFT stand, Taxilane CL, Taxilane side stripe and Stand ID (LGT) Apron stop bar LGT Other: (Marking) Overrun area

Surface Painted Direction Sign and Surface Painted Location Sign

1. Type of Surface Painted Markings
(1)Surface Painted Direction Sign
This type of marking at a taxiway intersection indicates the designation and direction of the taxiway leading out of an intersection. Black inscriptions with an arrow with a yellow background.
(2)Surface Painted Location Sign
This type of marking indicates the designation of the taxiway on which the aircraft is located. Yellow inscriptions with a black background and a yellow frame.
2. On the Taxiways at multi-crossing junctions and the standard taxiing routes, surface painted taxiway location and direction markings are provided as shown below.



APRON STOP BAR

1. Apron stop bars are provided on the aprons. (Refer to the taxiing charts for their locations). Each apron stop bar consists of five lights, illuminated in red towards the direction of the aircraft movement and when turned on by ramp controllers. Apron stop bars designated No.1 and 2 are used for arriving aircraft and No.4, No.5 and 6 are used for both arriving and departing aircraft.
2. Aircraft is required to hold at apron stop bars until the red lights are turned off and "CLEARED TO TAXI" is given by radio.
3. As shown below, the red lights are visible when an aircraft following the yellow apron taxiway center line/green center line light approaches the apron stop bar.

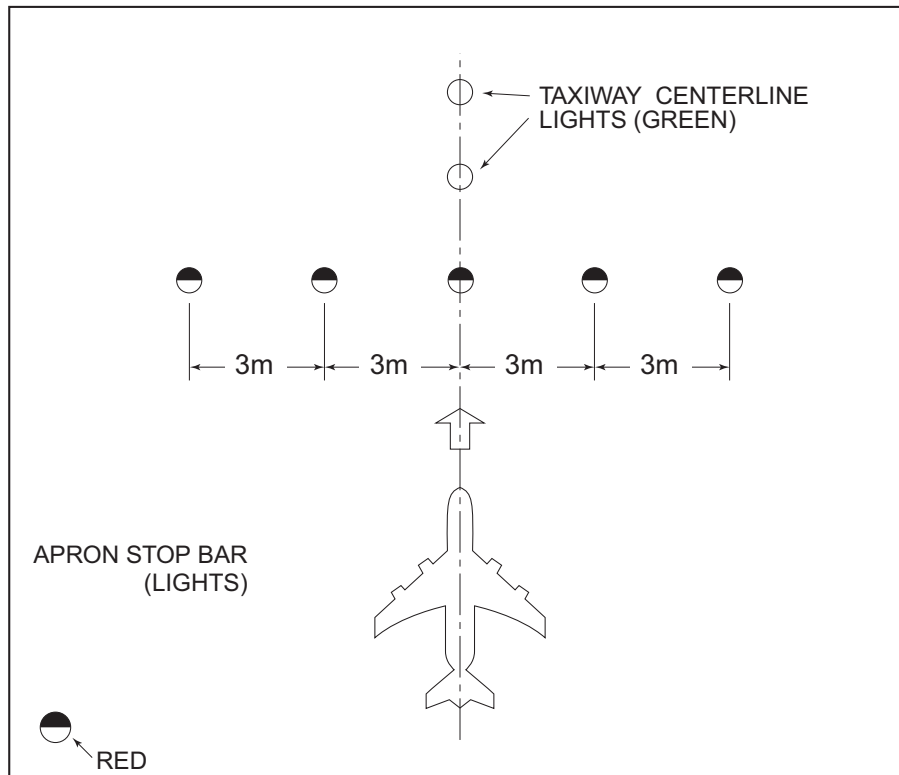

VISUAL DOCKING GUIDANCE SYSTEM

1. General

- (1) The pilots of an arriving aircraft assigned to park at one of these parking stands can use this system to be guided and stop the aircraft at the correct parking position.
- (2) This system is operational only in the automatic mode and in an event of a system failure, the aircraft shall be manually guided by a marshaller to the stopping position.
- (3) The visual docking guidance system consists of a display screen for pilots and a laser scanner. The system detects and analyses the aircraft type of an approaching aircraft, tracks it through the laser scanner, and displays these results on the display screen.
- (4) The display screen indicates the following information:
 - a) type of the approaching aircraft,
 - b) deviation from the lead-in center line, and
 - c) distance to the stopping position.

The above information is provided equally to the pilots on both left seat and right seat.

- (5) The following aircraft parking stands are equipped with a visual docking guidance system:
 - Safedock Type 1 (T1): NR11, 12, 14-17, 22-27, 31-38, 41-47, 51-56, 57A, 57B, 58A, 58B
 - Safedock Type 2 (T2): NR61-68, 71-75, 81-88, 91-99

2. Safedock Type 1 (T1)

2.1 Aircraft Type Indication

- (1) An operator on ground shall input the aircraft type into the system before the aircraft approaches the parking stand. Upon accepting the input, the system carries out internal calibration, starts the laser scanner simultaneously, and indicates the aircraft type according to the input. The system then will begin to indicate yellow lead-in arrows scrolling upwards prompting the aircraft to proceed (Fig.1).



Fig. 1

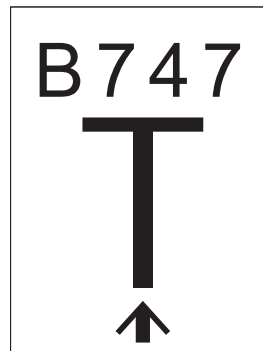

Fig. 2

- (2) When the laser scanner detects the approaching aircraft, the display screen will indicate the aircraft type, a "T" bar, and a lead-in upward arrow in yellow (Fig.2).
- (3) At least until the approaching aircraft arrives at a point 15m before the stopping position, the system will identify the aircraft type and will compare with the previously input aircraft type. If these data match, the system will continue its operation. If they do not match, the display screen will continue displaying "STOP", "ID FAIL" (Fig.3).

NOTE : At this moment, the pilots must stop the aircraft immediately.

When the operator re-input the correct aircraft type into the system and the system finds it correct, it resumes normal operations indicating the correct aircraft type on its display screen.



Fig. 3

2.2 Spot-in and Lateral Center line Guidance

- (1) When entering an aircraft parking stand using the system, the pilots should maneuver the aircraft at a low speed to the stopping position. In an event when "SLOW" is indicated on the display screen, the pilots should further decelerate the taxiing speed to avoid overshooting(Fig.4).

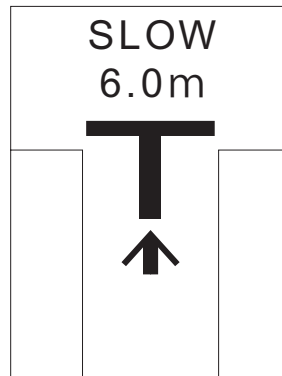

Fig. 4

- (2) Deviation of an upward yellow arrow from the center line of "T" indicates the deviation of the approaching aircraft relative to the center line of the parking stand either to right or left. Further, an additional flashing red arrow on the either side indicates the required direction for the aircraft to turn (Fig.5, Fig.6), and numerical value of remaining distance (Fig.7, Fig.8).

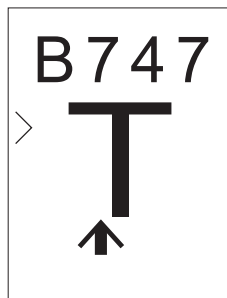

Fig. 5

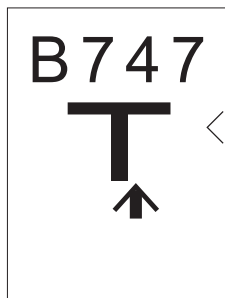

Fig. 6

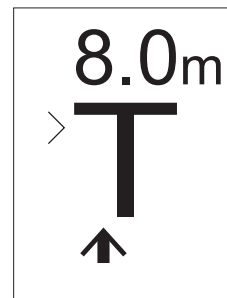

Fig. 7

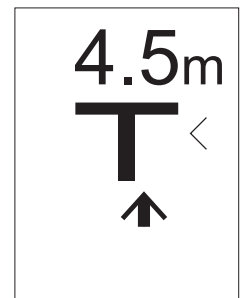

Fig. 8

2.3 Stop Guidance

- (1) When the approaching aircraft is within 20m from the stopping position, the shaft of the illuminated "T" will start to reduce in its length from the bottom to indicate the approaching rate of the aircraft, indicating the remaining distance to the stopping position successively (Fig.9, Fig.10).
As the aircraft approaches the stopping position, the shaft of the illuminated "T" retract one row for every 0.3m.

When the approaching aircraft is within 30m from the stopping position, display of digital countdown will start. As the aircraft approaches the stopping position, digital countdown is for every 1.0m (from 30 to 5m to the stopping position) or for every 0.5m (from 5 to 2m to the stopping position) or for every 0.1m (from 2m to the stopping position) (Fig.11, Fig.12).

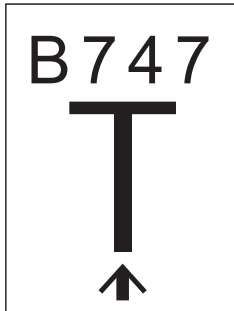

Fig. 9

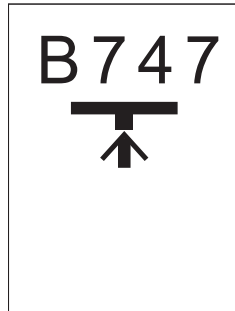

Fig. 10

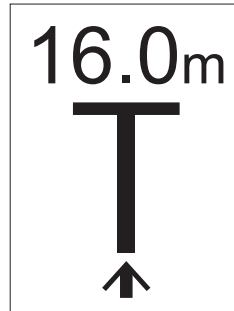

Fig. 11

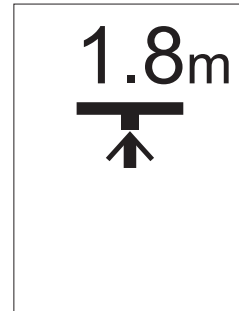

Fig. 12

- (2) When the aircraft reaches the stopping position, a message "STOP" with a red border will be displayed on the screen (Fig.13).

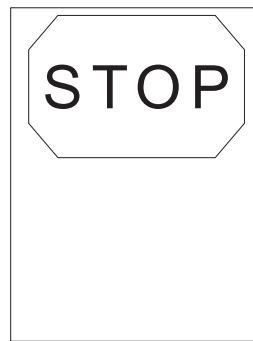

Fig. 13

- (3) When the aircraft is stopped at the correct stopping position, a message "OK" will be displayed on the screen in several seconds(Fig.14).

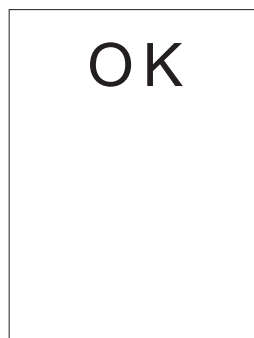

Fig. 14

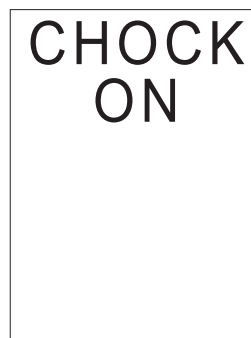

Fig. 15

- (4) When the operator applies chocks, and switches on "CHOCK ON" switch, a message "CHOCK ON" will be displayed on the screen(Fig.15).

- (5) If the aircraft stops at a position beyond the correct stopping position, a message "TOO FAR" will be displayed on the screen(Fig.16).



Fig. 16

2.4 Cautions and Safety

- (1) When the system displays an incorrect aircraft type, or when such a message as "STOP", "ID", "FAIL", or "WAIT" appears on the display screen, the pilots should stop the aircraft immediately (Fig.3, Fig.13, Fig.17).

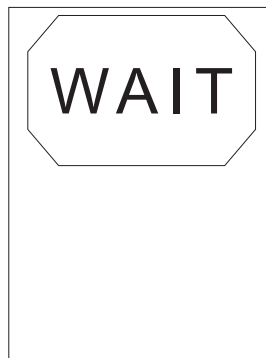

Fig. 17

- (2) During heavy fog, rain or snow the visibility for the docking system can be reduced. When the system is activated and in capture mode, the display will deactivate the floating arrows and show "SLOW" (Fig.18). The message will be superseded by the closing rate bar as soon as the system detects the approaching aircraft. The pilot must not proceed beyond the passenger boarding bridge, unless the "SLOW" message has been superseded by the closing rate bar.



Fig. 18

3. Safedock Type 2 (T2)

3.1 Aircraft Type Indication

- (1) An operator on ground shall input the aircraft type into the system before the aircraft approaches the parking stand. Upon accepting the input, the system carries out internal calibration, starts the laser scanner simultaneously, and indicates the aircraft type according to the input. The system then will begin to indicate yellow lead-in arrows scrolling upwards prompting the aircraft to proceed (Fig.19).

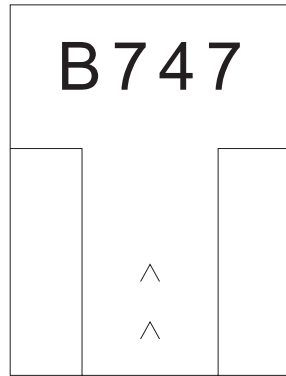

Fig. 19

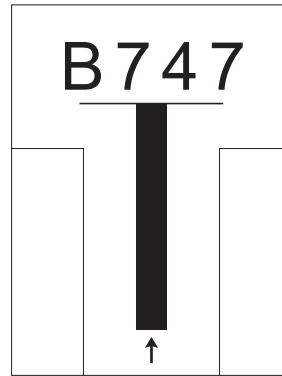

Fig. 20

- (2) When the laser scanner detects the approaching aircraft, the display screen will indicate the aircraft type, a “T” bar, and a lead-in upward arrow in yellow (Fig.20).
- (3) At least until the approaching aircraft arrives at a point 12m before the stopping position, the system will identify the aircraft type and will compare with the previously input aircraft type. If these data match, the system will continue its operation. If they do not match, the display screen will repeatedly indicate “STOP”, “ID” and “FAIL” in sequence and will indicate 2 illuminated red squares simultaneously (Fig.21 to Fig.23).

NOTE: At this moment, the pilots must stop the aircraft immediately.

When the operator re-input the correct aircraft type into the system and the system finds it correct, it resumes normal operations indicating the correct aircraft type on its display screen.

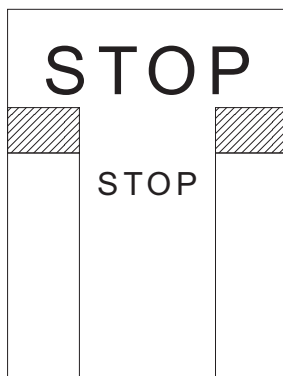

Fig. 21

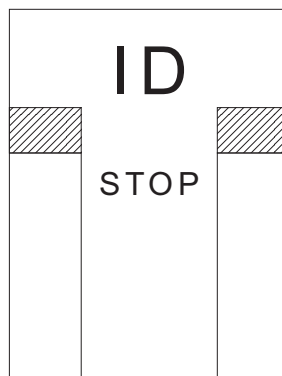

Fig. 22

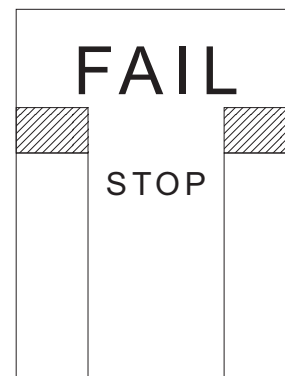

Fig. 23

3.2 Spot-in and Lateral Center line Guidance

- (1) When entering an aircraft parking stand using the system, the pilots should maneuver the aircraft at a low speed to the stopping position. In an event when “SLOW DOWN” is indicated on the display screen, the pilots should further decelerate the taxiing speed to avoid overshooting (Fig.24).

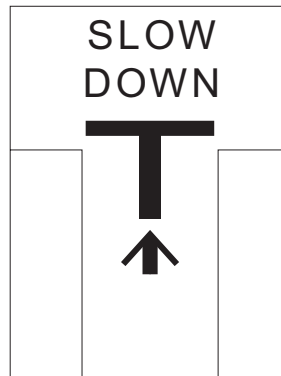

Fig. 24

- (2) Deviation of an upward yellow arrow from the center line of "T" indicates the deviation of the approaching aircraft relative to the center line of the parking stand either to right or left. Further, an additional flashing red arrow on the either side indicates the required direction for the aircraft to turn (Fig25, Fig.26).

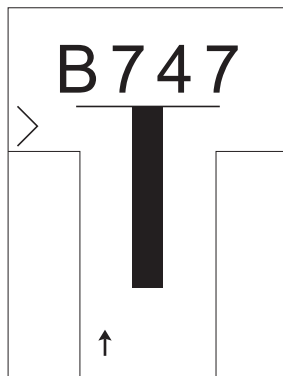

Fig. 25

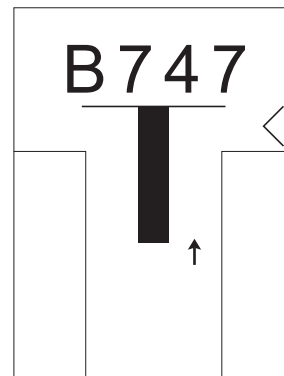

Fig. 26

3.3 Stop Guidance

- (1) When the approaching aircraft is within 16m from the stopping position, the shaft of the illuminated "T" will start to reduce in its length from the bottom to indicate the approaching rate of the aircraft, indicating the remaining distance to the stopping position successively (Fig.27 ,Fig.28).
As the aircraft approaches the stopping position, the shaft of the illuminated "T" retract one row for every 0.5m.

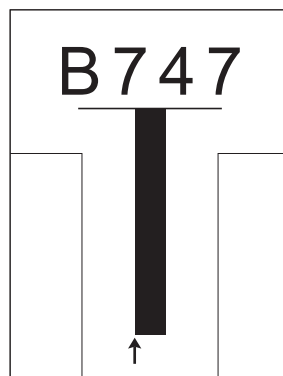

Fig. 27

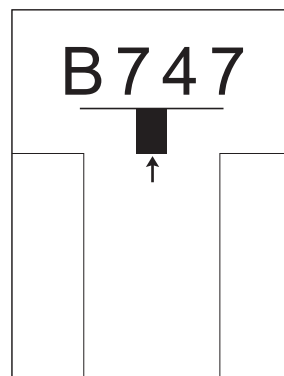

Fig. 28

- (2) When the aircraft reaches the stopping position, a message “STOP” will be displayed on the screen together with two red squares, one each at the either side of the screen at the positions previously used for indication of a direction to turn (Fig.29).

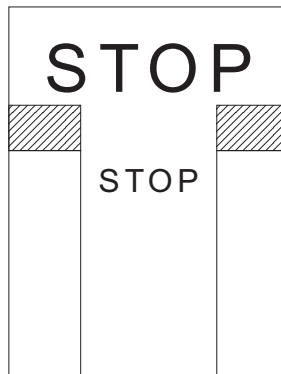

Fig. 29

- (3) When the aircraft is stopped at the correct stopping position, a message “OK” will be displayed on the screen in several seconds (Fig.30).

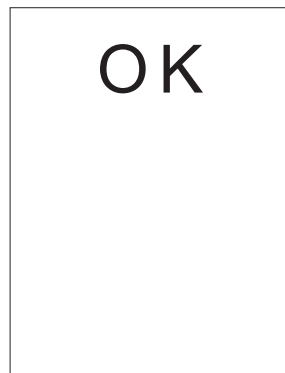

Fig. 30



Fig. 31

- (4) When the operator applies chocks, and switches on “CHOCK ON” switch, a message “CHOCK ON” will be displayed on the screen (Fig.31).
- (5) If the aircraft stops at a position beyond the correct stopping position, a message “TOO FAR” will be displayed on the screen (Fig.32).



Fig. 32

3.4 Cautions and Safety

- (1) When the system displays an incorrect aircraft type, or when such a message as “STOP”, “ID”, “FAIL”, or “WAIT” appears on the display screen, the pilots should stop the aircraft immediately (Fig.21 to Fig.23 Fig.29, Fig.33).

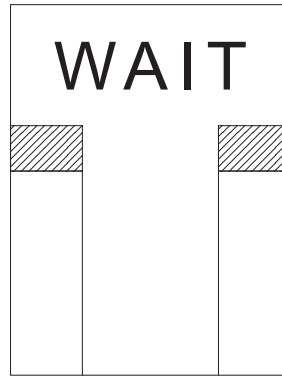

Fig. 33

- (2) During heavy fog, rain or snow the visibility for the docking system can be reduced. When the system is activated and in capture mode, the display will deactivate the floating arrows and show "DOWN GRADE" (Fig.34, Fig.35). The message will be superseded by the closing rate bar as soon as the system detects the approaching aircraft. The pilot must not proceed beyond the passenger boarding bridge, unless the "DOWN GRADE" message has been superseded by the closing rate bar.

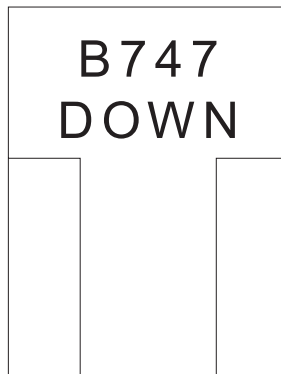
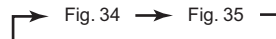

Fig. 34

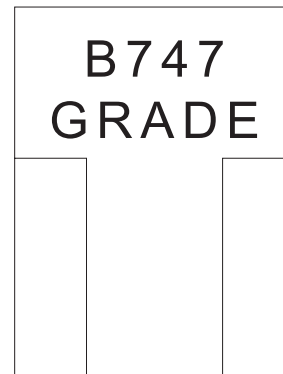
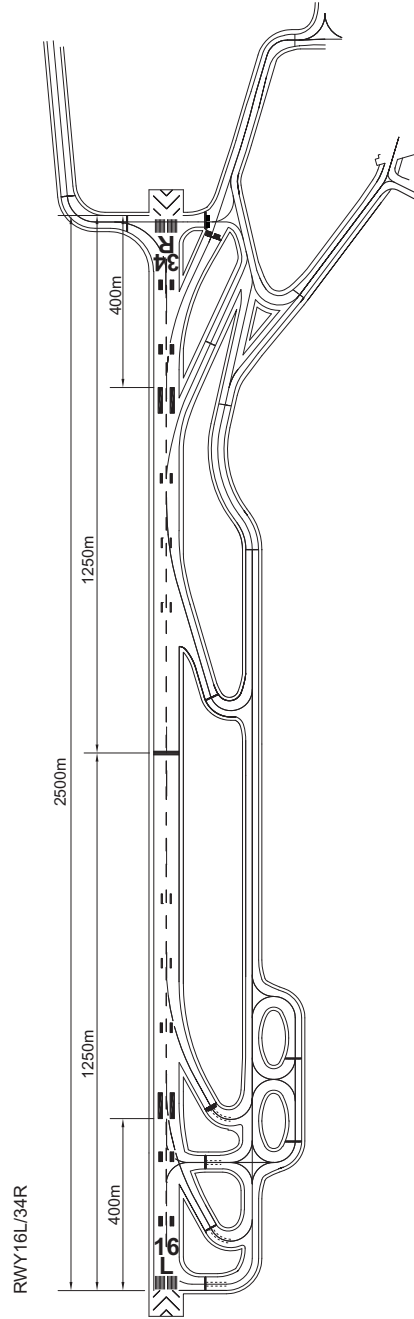
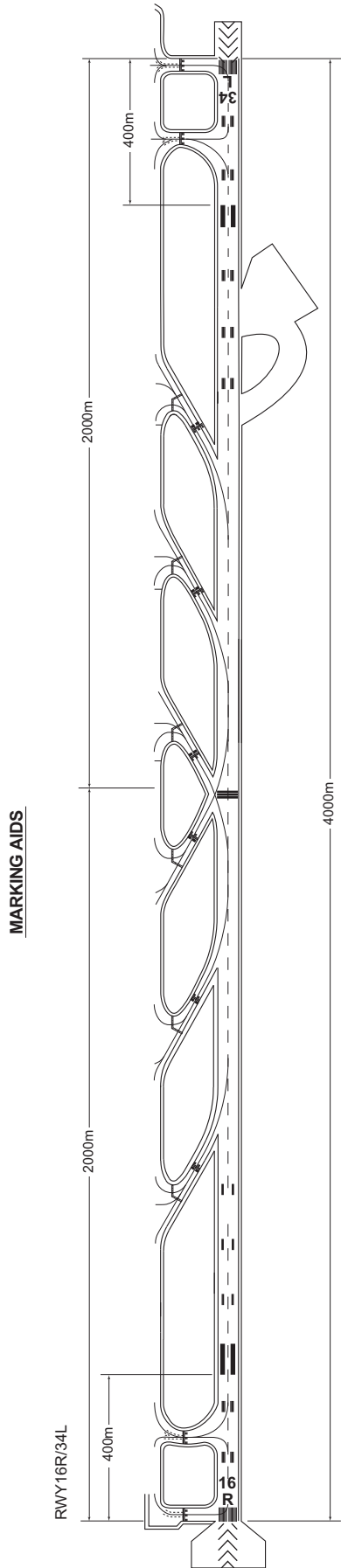

Fig. 35



Marking aids



RJAA AD 2.10 AERODROME OBSTACLES

In Area2 See Obstacle data

In Area3 To be developed

RJAA AD 2.11 METEOROLOGICAL INFORMATION PROVIDED

1	Associated MET Office	NARITA
2	Hours of service MET Office outside hours	H24
3	Office responsible for TAF preparation Periods of validity	NARITA 30 Hours
4	Trend forecast Interval of issuance	TREND 30min.
5	Briefing/ consultation provided	P, Ja, En
6	Flight documentation Language(s) used	C En
7	Charts and other information available for briefing or consultation	S ₆ , U ₈₅ , U ₇ , U ₅ , U ₃ , U ₂₅ , U ₂ /T _r , P _S , P ₅ , P ₃ , P ₂₅ , P _{SWE} , P _{SWF} , P _{SWG} , P _{SWI} , P _{SWM} , P _{SW} (domestic), E, C, W _E , W _F , W _G , W _I , W, N
8	Supplementary equipment available for providing information	Doppler Radar and Lidar for Airport Weather (See attached chart)
9	ATS units provided with information	TWR, APP, ATIS
10	Additional information (limitation of service, etc.)	Nil

Airspace for the advisory service concerning low level wind shear

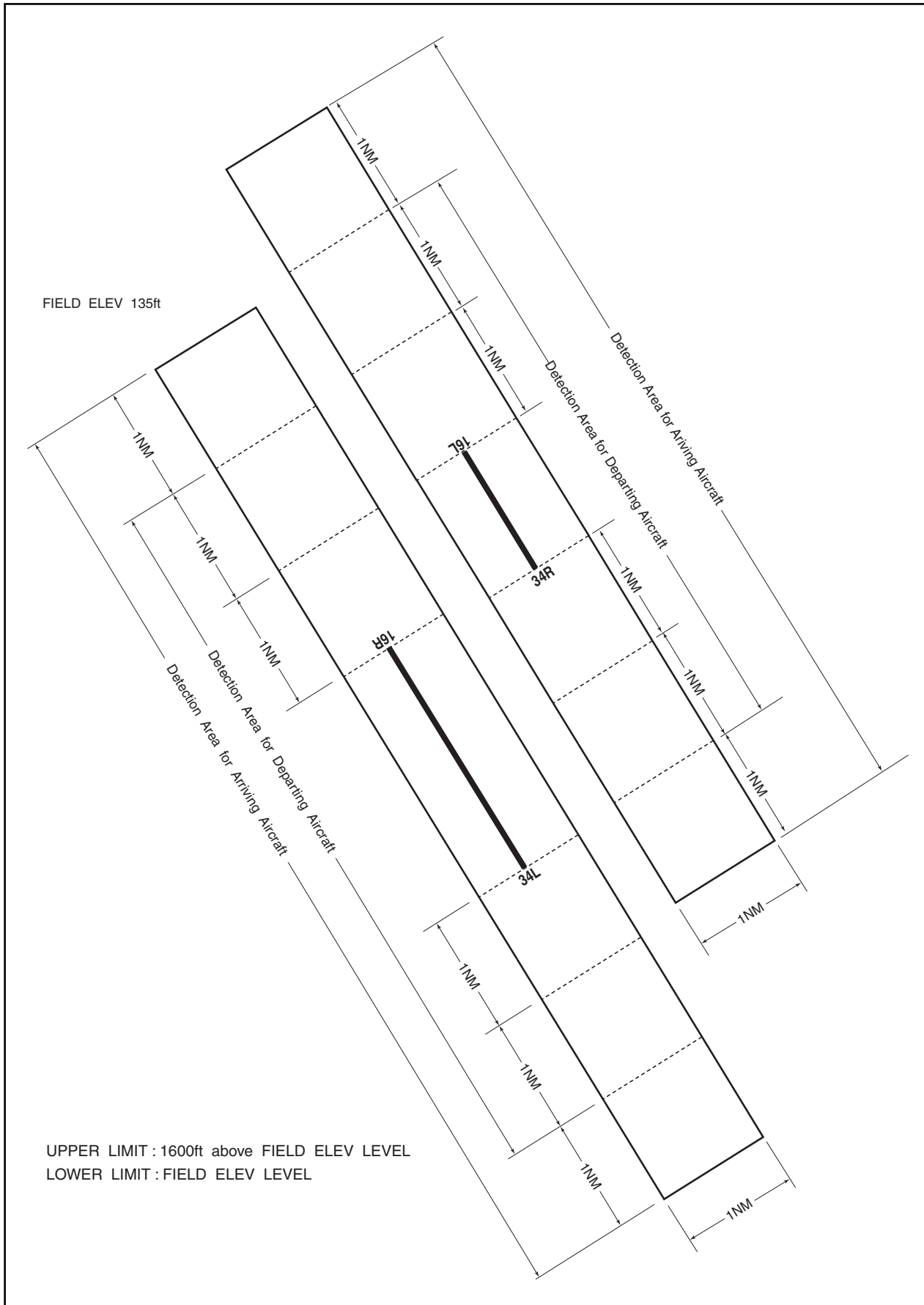

RJAA AD 2.12 RUNWAY PHYSICAL CHARACTERISTICS

Designations RWY NR	TRUE BRG	Dimensions of RWY(M)	Strength(PCN) and surface of RWY	THR coordinates THR geoid undulation	THR elevation and highest elevation of TDZ of precision APP RWY
1	2	3	4	5	6
16R	149.50°	4000x60	PCN 140/F/C/X/T Asphalt	354627.80N 1402205.85E 116.4ft	THR ELEV:129.6ft TDZ ELEV : 130.0ft
34L	329.51°	4000x60	PCN 140/F/C/X/T Asphalt	354435.96N 1402326.66E 114.9ft	THR ELEV:139.4ft TDZ ELEV : 140.0ft
16L	149.50°	2500x60	PCN 129/F/C/X/T Asphalt	354818.72N 1402241.19E 117.2ft	THR ELEV:134.5ft TDZ ELEV : 134.5ft
34R	329.51°	2500x60	PCN 129/F/C/X/T Asphalt	354708.82N 1402331.72E 116.4ft	THR ELEV:141.1ft TDZ ELEV : 139.7ft
Slope of RWY		Strip Dimensions(M)		RESA (Overrun) Dimensions(M)	
7		10		11	
See below chart		4120x300		164 x 300	
		4120x300		90 x 300	
See below chart		2620x150		40 x 300	
		2620x150		240 x (MNM:120 MAX:300)* *For detail, ask airport administrator	
Remarks					
14					
Dimension of RWY16R/34L grooved area is 3825m x 60m from THR of RWY34L. NOTE : First 150m of RWY34L is paved by concrete, PCN is 140/R/C/X/T.					
Dimension of RWY16L/34R grooved area is 2500m x 60m. NOTE : First 440m of RWY16L is paved by concrete, PCN is 129/R/C/X/T.					
Slope of RWY					

RJAA AD 2.13 DECLARED DISTANCES

RWY Designator	TORA (m)	TODA (m)	ASDA (m)	LDA (m)	Remarks
1	2	3	4	5	6
16R	4000	4000	4000	4000	Nil
34L	4000	4000	4000	4000	Nil
16L	2500	2500	2500	2500	Nil
34R	2500	2500	2500	2500	Nil

RJAA AD 2.14 APPROACH AND RUNWAY LIGHTING

RWY Designator	APCH LGT type LEN INTST	RTHL Color WBAR	PAPI (VASIS) Angle DIST FM THR MEHT	RTZL LEN	RCLL LEN Spacing Color INTST	REDL LEN Spacing Color INTST	RENL Color WBAR	STWL LEN Color
1	2	3	4	5	6	7	8	9
16R	PALS (CAT III) 900m LIH	Green Green	PAPI 3.0°/Left 431m 67.3ft	900m	4000m 15m Coded color (White/Red) LIH	4000m 30m Coded color (White/Yellow) LIH	Red	Nil(*)
34L	PALS (CAT I) 750m LIH	Green Green	PAPI 3.0°/Left 425m 67.3ft	900m	4000m 15m Coded color (White/Red) LIH	4000m 30m Coded color (White/Yellow) LIH	Red	Nil(*)
16L	PALS (CAT I) 900m LIH	Green Green	PAPI 3.0°/Left 419m 65.6ft	900m	2500m 30m Coded color (White/Red) LIH	2500m 30m Coded color (White/Yellow) LIH	Red	Nil(*)
34R	PALS (CAT I) 900m LIH	Green Green	PAPI 3.0°/Right 460m 66.2ft	900m	2500m 30m Coded color (White/Red) LIH	2500m 30m Coded color (White/Yellow) LIH	Red	Nil(*)
Remarks								
10								
(*) Overrun area edge LGT(LEN:60m, color:Red)								

RJAA AD 2.15 OTHER LIGHTING, SECONDARY POWER SUPPLY

1	ABN/IBN location, characteristics and hours of operation	ABN: 354511N/1402400E,White/Green EV4.3sec, HO
2	LDI location and LGT Anemometer location and LGT	LDI : Nil Anemometer : RWY 34L : 276m from RWY 34L THR, LGTD RWY 16R : 397m from RWY 16R THR, LGTD RWY 34R : 415m from RWY 34R THR, LGTD RWY 16L : 485m from RWY 16L THR, LGTD
3	TWY edge and center line lighting	TWY edge and center line lights installed.see AD 2.9
4	Secondary power supply/ switch-over time	Within 1sec: PALS(RWY16R/34L), PAPI, RENL, RTHL, WBAR, RCLL, RTZL, Stop bar LGT and RWY guard LGT(B1-B9) Within 15sec:Other lights
5	Remarks	WDI LGT

RJAA AD 2.16 HELICOPTER LANDING AREA

Nil

RJAA AD 2.17 ATS AIRSPACE

Designation and lateral limits		Vertical limits (ft)	Airspace classification	ATS unit call sign Language	Remarks
1		2	3	4	6
NARITA CTR	Area defined as follows. (1) Area within a radius of 5nm of NARITA INTERNATIONAL ARP (3546N14023E). (2) Area within a line connecting 354826N 1401749E, 355054N 1402341E, 355238N 1402225E, 354957N 1401647E and 354826N 1401749E	3000 or below	D	NARITA TWR En	exclude area(1)
NARITA PCA	See attached chart		C	TOKYO APP(1) NARITA TWR(2) En	(1)Primary (2)Secondary
TOKYO ACA	See RJTT attached chart		E	TOKYO APP TOKYO DEP TOKYO RADAR En	
TOKYO TCA	See RJTT attached chart		E	TOKYO TCA En	

成田特別管制区
Narita Positive Control Area

NAME	LATERAL LIMITS	UPPER LIMIT (AMSL)	UNIT PROVIDING SERVICE	REMARKS
		LOWER LIMIT (AMSL) M(ft)		
1	2	3	4	5
成田 Narita	下記に示された区域 The area shown below		Primary Tokyo APP 124.4 127.7 261.2 Secondary Narita Tower 118.2 118.35 236.8	当該空域を飛行しようとする航空機は東京アプローチ又は成田タワーに連絡し、コールサイン、現在位置、高度及び意図を通報し指示を受けること。 Pilot of aircraft operating in this area shall contact Tokyo APP or Narita Tower for ATC instructions giving information on aircraft identification, position, altitude and pilot's intentions.

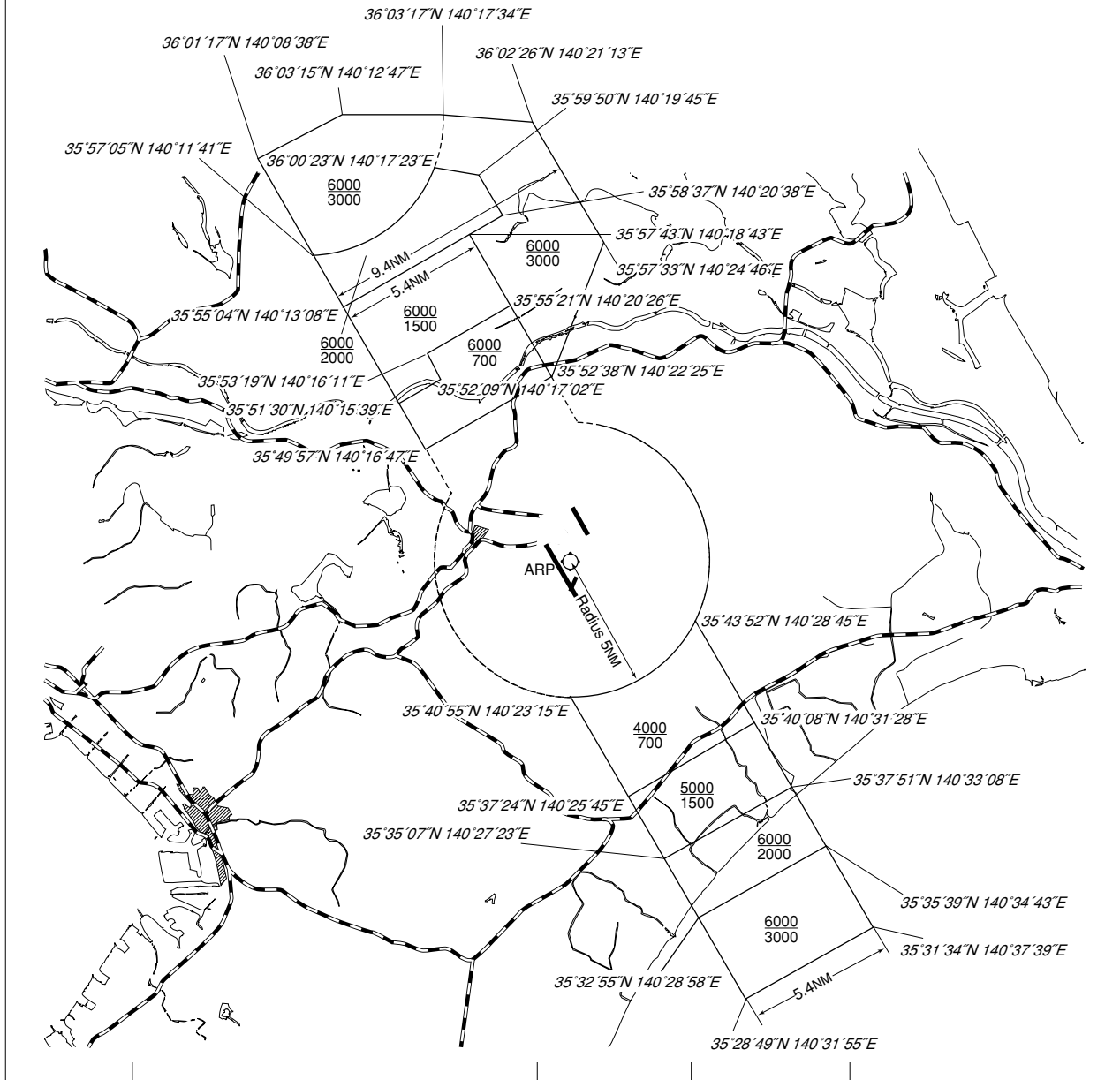

RJAA AD 2.18 ATS COMMUNICATION FACILITIES

Service designation	Call sign	Frequency	Hours of operation	Remarks
1	2	3	4	5
APP	Tokyo Approach	124.4MHz(1) 121.275MHz 125.2MHz 125.8MHz 127.7MHz 225.65MHz 121.5MHz(E) 243.0MHz(E)	H24	(1)Primary
ASR	Tokyo Radar	120.2MHz 121.5MHz(E) 243.0MHz(E)	H24	
DEP	Tokyo Departure	124.2MHz(1) 119.6MHz 120.6MHz 125.525MHz 127.5MHz	H24	
TCA	Tokyo TCA	119.45MHz 246.1MHz	2300 - 1030	
TWR	Narita Tower	118.2MHz(1) 118.35MHz 122.7MHz 126.2MHz 236.8MHz 121.5MHz(E) 243.0MHz(E)	H24	
GND	Narita Ground	121.95MHz(1) 121.85MHz	H24	
DELIVERY	Narita Delivery	121.9MHz(1) 121.65MHz	H24	
ATIS	Narita INTL Airport	128.25MHz	H24	
RAMP	Narita Ramp Control	121.6MHz 121.75MHz 118.15MHz 121.7MHz	H24	See RJAA AD2.20 2.1.1 Ramp control
A/G	Tokyo	(2)	H24	(2)SELCAL AVBL HF* RDO CK AVBL. *LOCAL HF AT NARITA INTL AP. NP: 2932KHz 5628KHz 5667KHz 6655KHz 8915KHz 8951KHz 10048KHz 11330KHz 13273KHz 17946KHz 21925KHz CWP: 2998KHz 3455KHz 4666KHz 6532KHz 8903KHz 11384KHz 13300KHz 17904KHz

RJAA AD 2.19 RADIO NAVIGATION AND LANDING AIDS

Type of aid (VOR declination)	ID	Frequency	Hours of operation	Position of transmitting antenna coordinates	Elevation of DME transmitting antenna	Remarks
1	2	3	4	5	6	7
VOR	NRE	117.9MHz	H24	354656.44N/1402145.13E		VOR unusable: 110°-120° beyond 15nm BLW 3000ft. 120°-150° beyond 25nm BLW 3000ft. 170°-180° beyond 35nm BLW 3000ft. 210°-220° beyond 35nm BLW 4000ft. 260°-270° beyond 35nm BLW 3000ft. 280°-300° beyond 25nm BLW 3000ft Note:There is a course roughness due to crossing over the station by other aircraft.
DME	NRE	1213MHz (CH-126X)	H24	354656.44N/1402145.13E	153ft	DME unusable: 060°-110° beyond 30nm BLW 3000ft. 110°-120° beyond 20nm BLW 3000ft. 130°-140° beyond 25nm BLW 3000ft. 140°-150° beyond 35nm BLW 4000ft. 260°-270° beyond 35nm BLW 3000ft. 280°-300° beyond 25nm BLW 3000ft.
ILS-LOC 16R (CAT-III)	IKF	111.5MHz	H24	354422.75N/1402336.17E		Back course unusable. LOC : 472m(1549ft) away FM RWY34L THR, BRG(MAG) 157°.
ILS-GP 16R	-	332.9MHz	H24	354616.14N/1402208.25E		GP:340m(1115ft) inside FM RWY16R THR,130m(427ft) W of RCL. GP angle 3.0°, HGT of ILS Ref datum 18.0m(59ft).
ILS-DME 16R	IKF	1013MHz (CH-52X)	H24	354616.17N/1402208.55E	142ft	DME : 343m(1125ft) inside FM RWY16R THR, 123m(404ft) W of RCL.
IM 16R	-	75MHz	H24	354635.61N/1402200.18E		IM : 280m(918ft) away FM RWY16R THR.
ILS-LOC 34L	IYQ	111.9MHz	H24	354640.25N/1402156.83E		Back course unusable. LOC : 446m(1463ft) away FM RWY16R THR. BRG(MAG) 337°.
ILS-GP 34L	-	331.1MHz	H24	354443.26N/1402315.36E		GP : 338m(1109ft) inside FM RWY34L THR, 130m(426ft) W of RCL. GP angle 3.0° HGT of ILS Ref datum 17.7m(58ft).
ILS-DME 34L	IYQ	1017.0MHz (CH-56X)	H24	354443.18N/1402315.19E	155ft	DME : 338m(1109ft) inside FM RWY34L THR, 135m(443ft) W of RCL.

Type of aid (VOR declination)	ID	Frequency	Hours of operation	Position of transmitting antenna coordinates	Elevation of DME transmitting antenna	Remarks
1	2	3	4	5	6	7
ILS-LOC 16L	ITM	110.7MHz	H24	354702.26N/1402336.44E		Back course unusable. LOC : 234m(767ft) away FM RWY34R THR, BRG (MAG) 157°
ILS-GP 16L	-	330.2MHz	H24	354810.90N/1402253.85E		GP : 369m(1210ft) inside FM RWY16L THR, 153m(500ft) E of RCL. GP angle 3.0°. HGT of ILS Ref datum 16.53m(54.2ft)
ILS-DME 16L	ITM	1005.0MHz (CH-44X)	H24	354810.82N/1402253.68E	142ft	DME: 369m(1210ft) inside FM RWY16L THR, 148m(484ft) E of RCL.
ILS-LOC 34R	ITJ	110.9MHz	H24	354826.12N/1402235.80E		Back course unusable. LOC : 265m(869ft) away FM RWY16L THR, BRG (MAG) 337°
ILS-GP 34R	-	330.8MHz	H24	354721.37N/1402330.81E		GP : 345m(1131ft) inside FM RWY34R THR, 177m(581ft) E of RCL. GP angle 3.0° HGT of ILS Ref datum 16.7m(54.9ft) .
ILS-DME 34R	ITJ	1007.0MHz (CH-46X)	H24	354721.45N/1402330.99E	149ft	DME : 345m(1131ft) inside FM RWY34R THR,182m(597ft) E of RCL.
DME	SND	1174MHz (CH-87X)	H24	355606.33N/1395852.43E	126ft	
MSAS		1575.42MHz	H24			Transmitting antennas are satellite based

ILS for RWY 16R

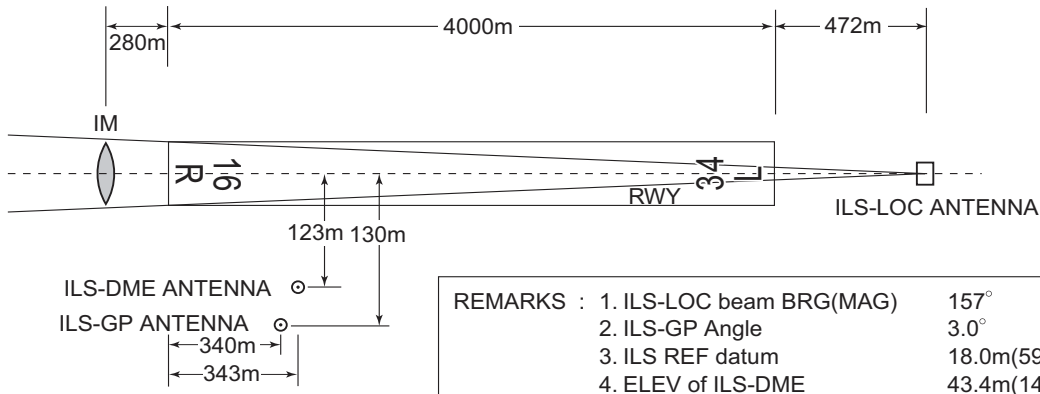

ILS for RWY 34L

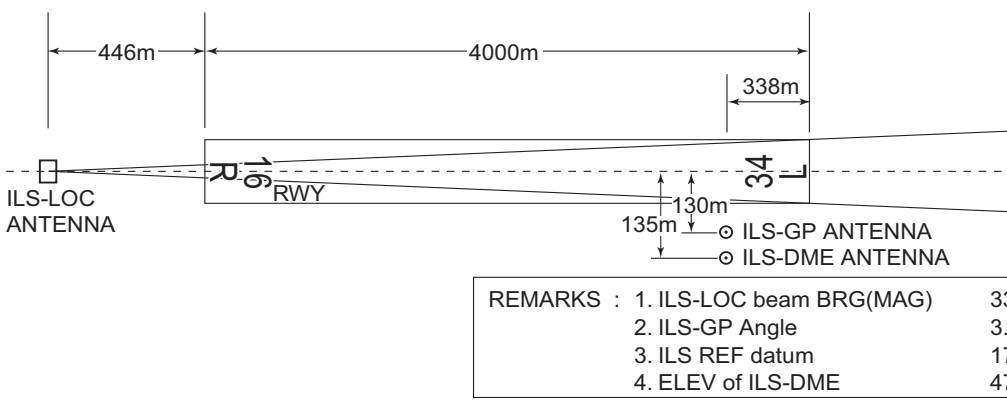

ILS for RWY 16L

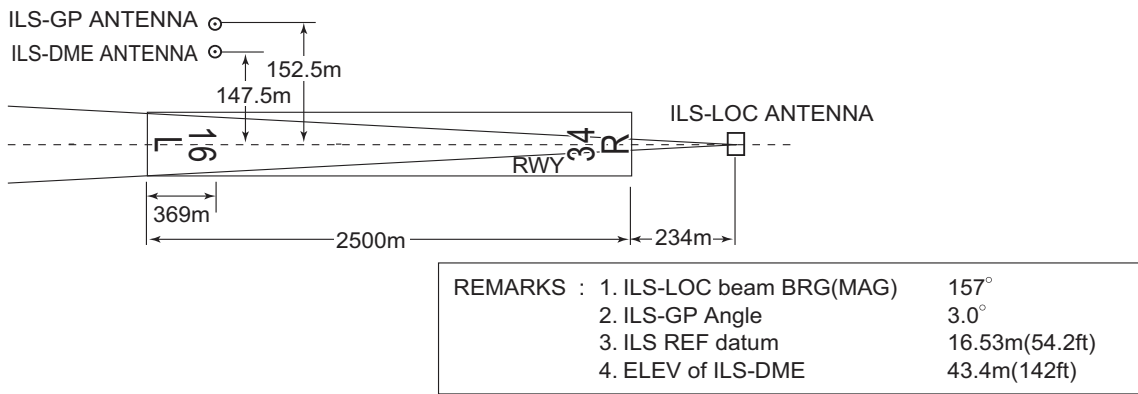

ILS for RWY 34R

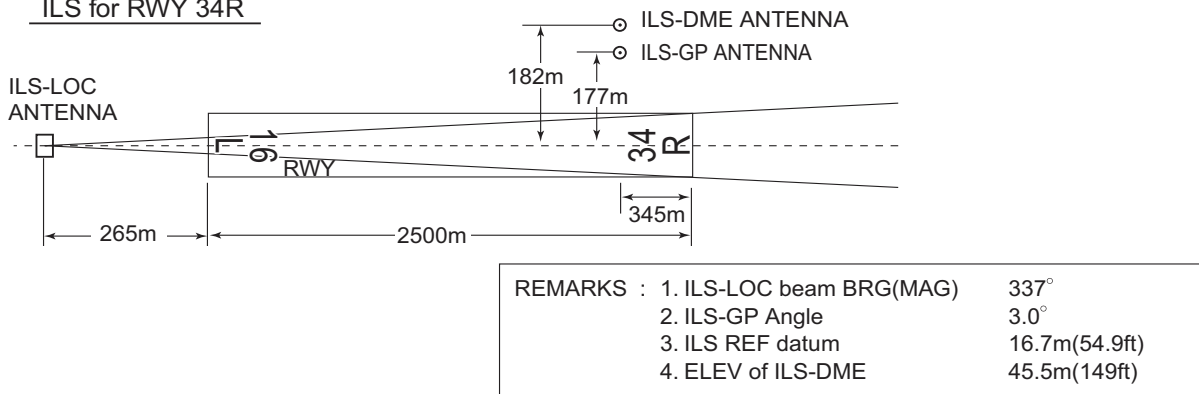

RJAA AD 2.20 LOCAL TRAFFIC REGULATIONS

1. Airport regulations

Local flying restrictions.

1.Noise restrictions

Time restrictions on departures and arrivals:

- (A) No take off or landing shall be permitted during the hours from 1500 UTC to 2100 UTC with the exception of aircraft in an emergency or in an unavoidable situation.

Note:"In an emergency or in an unavoidable situation" as described above shall be limited to the following cases:

- (a) Aircraft encountered with an abnormal situation.
- (b) When abnormal situation arose among crew or passengers.
- (c) Aircraft operating for the purpose of search-and-rescue activities.
- (d) Aircraft operating for the purpose of urgent news collection activities.
- (e) When take-off or landing is considered really unavoidable due to typhoon evacuation or other reasons.
- (f) When there arose necessity of urgent refuelling due to unusual weather conditions.

- (B) JCAB shall not accept flight plans in violation of the paragraph (A) above.

- (C) (1)Only RWY 16R/34L is available during the hours from 1400 UTC to 1500 UTC

- (2)All aircraft taking off from/landing at Narita International Airport during the hours from 1400UTC to 1500UTC shall meet the following requirement.

The sum of noise values of the aircraft is at least 10 EPNdB below the total noise standard values at the flyover, approach and sideline measurement points as defined in Annex16 to the Convention on International Civil Aviation Volume I Chapter 3 and all of the individual noise values measured at each of the measurement points are at least 2 EPNdB below the noise standard values at the corresponding points.

- (3)All aircraft scheduled to take off from/land at Narita International Airport during the hours from 2100UTC to 1400UTC shall also meet the criteria mentioned on paragraph (2) above in case they take off/land from 1400 UTC to 1500 UTC due to delay.

- (4)The provisions of the paragraph (1), (2), or (3) above shall not be applied in an emergency or in an unavoidable situation mentioned on the paragraph (A) above.

2.Operation

- (1) Efficient Use of 16L/34R

In order to maximize the operational efficiency of the airport, it is strongly encouraged for pilot to comply with the use of runway instructed by ATC, where ATC has determined its use upon giving due consideration to the overall traffic situation on the ground and in the air.

For this reason, arriving aircraft must be ready to accept landing on 16L/34R (2,500m) if ATC assigns the shorter runway.

Departing aircraft, upon giving due consideration of the distance to the destination as well as aircraft performance, must be ready to accept take-off from the runway assigned by ATC.

However, in the event where the assigned runway cannot be accepted due to unavoidable circumstances such as weather conditions, arriving aircraft must notify ATC of its intention at initial contact with Tokyo Approach and departing aircraft must notify ATC when requesting ATC clearance.

- (2) Arrival

All arriving aircraft should notify Ramp Control of assigned parking position (spot number) at initial contact.

- (3) Gear down operation during an approach to RWY34L/RWY34R.

In order to prevent ice blocks falling from aircraft onto the ground, all flights making an approach to RWY34L/RWY34R from the seashore are required to complete gear down and locked before reaching IYQ 11.8DME (NRE 14.3DME) for RWY 34L/ ITJ 13.6DME (NRE 14.0DME) for RWY34R as far as the safety of the flight is not compromised.

- (4) Missed approach

Pilot roles and responsibilities, when simultaneous parallel ILS approaches are being conducted.

If executing a missed approach prior to reaching the final approach fix (FAF), fly the lateral navigation path of the instrument procedure to the FAF. And,

- A) ILS Z RWY16L

Comply with restrictions in the Instrument Approach Procedure (IAP) chart until reaching MARCH, then maintain 3,000FT until reaching FAF, then climb to the altitude specified for the missed approach procedure, except when another altitude is instructed by the ATC.

- B) ILS RWY 34L

Maintain 4,000FT until reaching FAF, then climb to the altitude specified for the missed approach procedure, except when another altitude is instructed by the ATC.

- C) ILS Z RWY16R/ILS Z RWY34R

Climb to the altitude specified for the missed approach procedure, except when another altitude is instructed by the ATC.

- (5) On use of this airport for small aircraft

Take-off and landing of small aircraft shall be restricted by the airport authority excepting those engaged in security mission or permitted in advance.

3.PDA (parts departing aircraft) reporting to NAA

In order to secure the safety of aircraft operations and to rectify the issue of falling objects from aircraft operating in the vicinity of Narita International Airport, airline operators are required to notify NAA Ramp Control Office (Tel 0476-32-2246, Fax 0476-30-1586, E-mail unkan@naa.jp) of any "Parts Departing Aircraft" from flights operating to/from Narita International Airport, without delay. This information shall be shared by relevant parties in order to prevent recurrence of such.

4.Special notice to Airbus A380 operators (See A380 MOVEMENT AREA CHART)

- (1) Runway:
 - The only available runway for A380 is 16R/34L, and A380 is not permitted to use RWY 16L/34R.
 - It is required to use digital avionics: modern digital autopilot or flight director with track hold guidance, as RWY 16R/34L is with an ICAO Code E OFZ (obstacle free zone).
- (2) Runway-holding position:
 - RWY-holding position markings on A1, A2, A9 and A10 are located at 120m from runway center line. Clearance is adequate when A380 is properly holding on these holding positions.
- (3) Taxiway and apron:
 - A380 ground movement is only permitted within the areas as shown on the attached chart "A380 MOVEMENT AREA".
 - Reduced taxiway-taxilane center line separation of 90m is applied for simultaneous A380 taxi at W and R between W5 and S1, at W between C and W12, and at S1 between C and S. On these taxiways/taxilanes, A380 needs to reduce taxiing speed and accurately track the center lines.
 - A380 should take taxilane T9 to taxi to NR96.
 - Taxilane T9 marking is blue.
 - T9 aircraft stand taxi lane center line lights are illuminated in alternating GREEN and BLUE.
 - These lights are turned on by ramp controller for A380 aircraft arriving or departing to/from NR96 parking stand.
- (4) Taxiing route:
 - Unless there is a particular reason, A380 taxiing route is only permitted within the areas as shown on the attached chart "A380 MOVEMENT AREA".
- (5) Parking stand:
 - Available parking stands for A380 are: NR15, NR26, NR45, NR46, NR54, NR66, NR67, NR68, NR96, NR191, NR192, NR231, NR232, NR410, NR411, NR427, NR428, NR444, NR445, NR446, NR447, NR448, NR449, NR450, NR512, NR709, NR802 and NR807.
- (6) Ground power supply:
 - The fixed power facility is capable of supplying 180KVA at NR15, NR26, NR66, NR96, NR231 and NR232.
 - The fixed power facility is capable of supplying 300KVA at NR45 and NR46.
 - APU restriction is also applied to A380 as stipulated in RJAA AD2.21 Noise abatement procedures, (II) Other Information, (D)Restrictions about the use of auxiliary power unit (APU).

5.Special notice to Boeing B747-8 operators (See B747-8 MOVEMENT AREA CHART)

- (1) Runway:
 - All runways are available for B747-8.
 - It is required to use digital avionics: modern digital autopilot or flight director with track hold guidance, as all runways are with an ICAO Code E OFZ (obstacle free zone).
- (2) Taxiway and apron:
 - B747-8 ground movement is only permitted within the areas as shown on the attached chart "B747-8 MOVEMENT AREA".
 - Reduced taxiway center line-object separation is applied on K between B8 and E2. On this taxiway, B747-8 needs to reduce taxiing speed and accurately track the center line, as separation between wingtip and the boundary fence is 10.5m.
 - On taxiway D3, and N1 between D2 and D3, B747-8 is required to be towed during taxiing.
- (3) Taxiing route:
 - Unless there is a particular reason, B747-8 taxiing route is only permitted within the areas as shown on the attached chart "B747-8 MOVEMENT AREA CHART".
- (4) Parking stand:
 - Available parking stands for B747-8 are: NR26, NR67, NR68, NR191, NR192, NR204, NR205, NR207, NR208, NR209, NR210, NR211, NR231, NR232, NR410, NR411, NR422, NR423, NR424, NR425, NR426, NR427, NR428, NR443, NR444, NR445, NR446, NR447, NR448, NR449, NR450, NR512, NR702, NR703, NR704, NR705, NR706, NR707, NR708, NR709, NR710, NR801, NR802, NR803, NR804, NR805, NR806, NR807, NR808, NR902, NR903 and NR904.

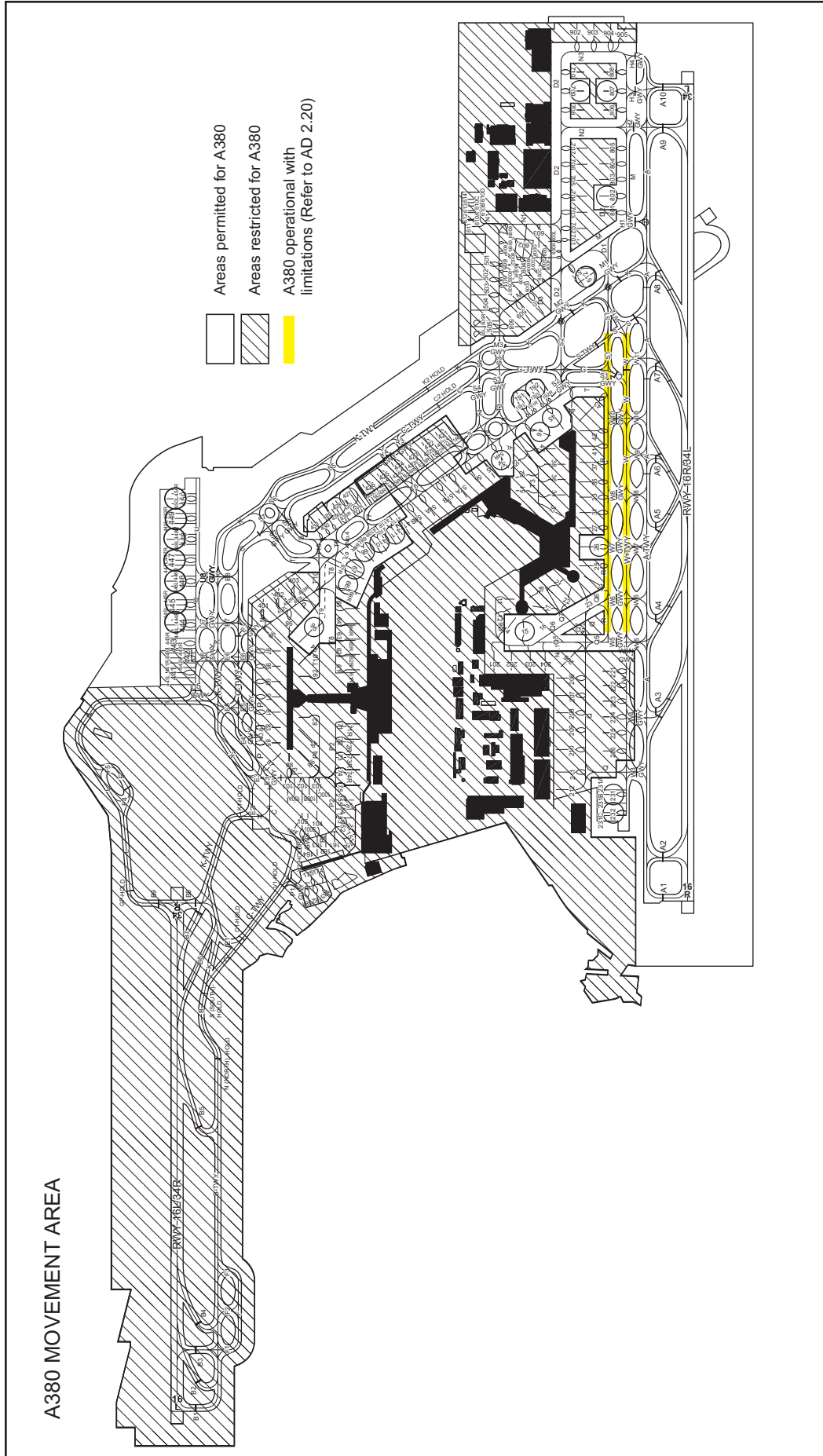

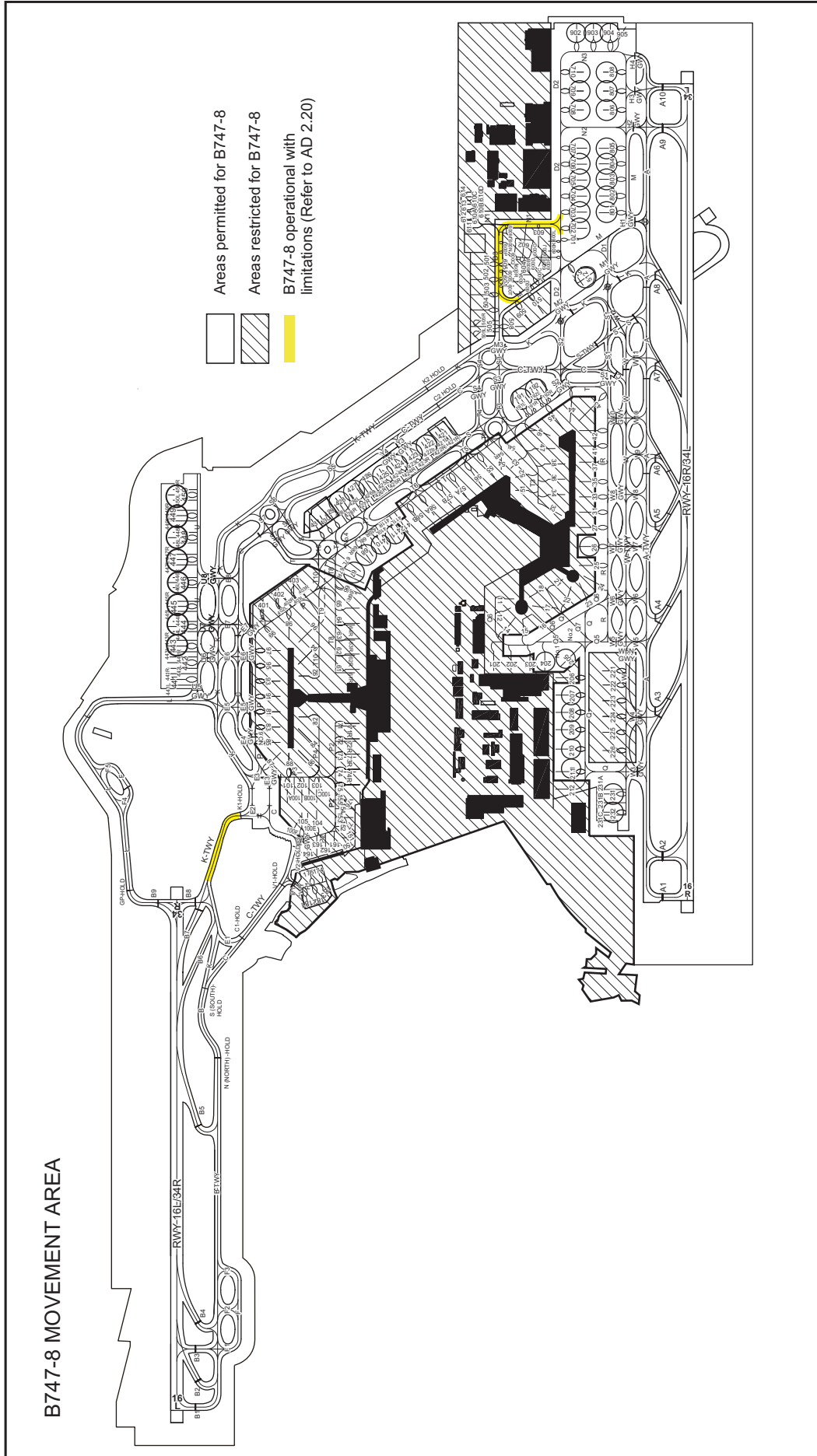

2. Taxiing to and from stands
2.1. GENERAL

1.Ramp control

(1) Ramp control services

With a view to ensuring a safe and smooth flow of aircraft traffic on the apron, the Narita International Airport Corporation operates an aeronautical station (Frequency : 121.6MHz, 121.75MHz and 118.15MHz Call sign : NARITA RAMP CONTROL) and issues instruction, approval, and/or necessary information to aircraft ground-moved within the apron areas.

(2) Area of Competence

The area of competence is shown below. The Ramp Control will only issue such instruction, approval, and/or information, which are effective within the apron areas.

(3) Procedures

(A) Start-up Taxi Procedures for Departing Aircraft from Terminal Apron

- (a) Contact NARITA DELIVERY 15 minutes prior to starting engines. (see AD 2.22(V)).
- (b) When instructed by ATC, contact NARITA RAMP CONTROL on 121.6MHz, 121.75MHz or 118.15MHz for approval to start push-back or taxiing.
- (c) Taxi is to be started from a safe position with due regard to the effects of engine exhaust blast.
- (d) Unless otherwise specified by the "NARITA RAMP CONTROL", follow the route to the gateway (exit from/entrance to apron) from the aircraft parking position, as shown on the Taxiing Charts.
- (e) Expect instructions to contact NARITA GROUND on 121.95MHz or 121.85MHz before leaving apron.
- (f) The name of the approaching gateway shall be reported at the initial contact with NARITA GROUND.
- (g) To avoid frequency congestion, report the current ATIS code to NARITA GROUND upon initial contact.

NOTE: DO NOT PROCEED INTO TAXIWAY WITHOUT TAXI INSTRUCTION FROM ATC.

(B) Taxi Procedures for Arriving Aircraft into Terminal Apron

- (a) When instructed by ATC, contact NARITA RAMP CONTROL on 121.6MHz, 121.75MHz or 118.15MHz for approval to continue taxiing into the apron.
- (b) The name of the approaching gateway shall be reported at the initial contact with NARITA RAMP CONTROL.
- (c) Unless otherwise specified by the "NARITA RAMP CONTROL", follow the route to the parking position from the gateway, as shown on the Taxiing Charts.
- (d) When holding at an apron stop bar shown on the above chart, stop the aircraft in front of stop bar lights.
- (e) When approaching the assigned parking position, reduce engine power to the extent practicable so as not to cause any hazard to others with due regard to exhaust blast.

NOTE: DO NOT PROCEED INTO APRON WITHOUT APPROVAL FROM RAMP CONTROL.

(C) Ground Movement of Aircraft other than Departing and Arriving Aircraft

Obtain an approval for taxi from the "NARITA RAMP CONTROL" prior to its start, then conform to the provisions of the paragraph (A) (Item (a), (b) and (g) are excluded) and (B).

(D) Ground Movement of Towed Aircraft

Towed aircraft is also subject to the Ramp Control. For details, see the Aircraft Operations Regulations (UNYOKANRI SAISOKU).

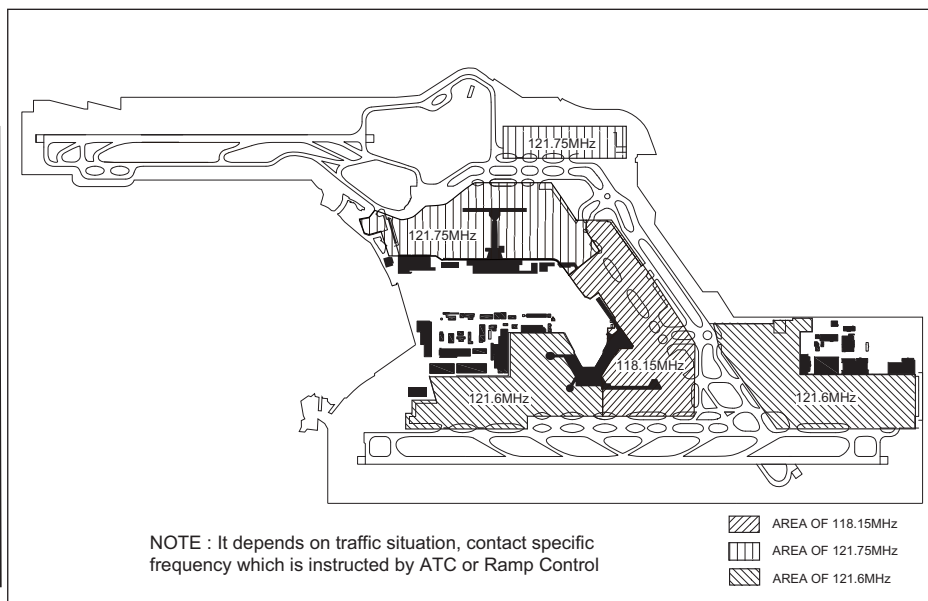

2.2. TSAT Operation

1. Definition

Words are defined as follows;

1-1 TSAT (Target Start Up Approval Time)

A target time at which an aircraft can expect to receive the off-block (including pushback and self-taxiout) approval

1-2 TOBT (Target Off-Block Time)

A target time at which an aircraft is ready for off-block immediately upon reception of clearance from Narita Ramp Control

1-3 TSAT Operation

The operation designates the off-block time using TSAT, which aims to improve the capacity of runway and optimize taxi times on the ground

2. Subject Aircraft

All IFR departures whose EOBT stated in flight plan between 2100UTC and 1130UTC except for a following aircraft.

- (1)An aircraft whose EDCT is 60 minutes or more after EOBT due to flow control, including when this EDCT is changed or cancelled.
- (2)An aircraft that is assigned to hold on the ground due to flow control.

3. Operation procedures

3-1 TOBT

3-1-1 Aircraft Operator (AO)/Ground Handler (GH) should report TOBT no later than 25 minutes prior to EOBT. EOBT stated in flight plan will be processed as TOBT if manual input of TOBT cannot be accomplished.

3-1-2 TOBT should be input via Narita Airport Collaborative Decision Making (CDM) System ("CDM System").

3-1-3 TOBT can never be earlier than 15 minutes prior to EOBT, nor later than 30 minutes after EOBT.

3-1-4 An aircraft should be ready within +/-5 minutes of TOBT. If the aircraft is not ready within +/-5 minutes of last reported TOBT, the AO/GH should update TOBT accordingly.

3-1-5 Delay message described in AIP ENR 1.11.2.2 may not be substituted by TOBT.

3-2 Issue of TSAT

3-2-1 TSAT is issued by Voice radiotelephone (Voice RTF) or data link at Clearance Delivery.

[Example]

Voice RTF "TSAT 0930"

Data link "TSAT 0930"

3-2-2 TSAT is displayed on Visual Docking Guidance System (VDGS) 20 minutes prior to the TSAT. It should be noted that TSAT is generated 20 minutes prior to EOBT.

[Example]

First row: "TSAT", Second row: TSAT (in time),

Third row: Countdown to TSAT in minutes. (Figure 1)

After countdown of "0", it is displayed as "DLA" for 30 minutes. (Figure 2)

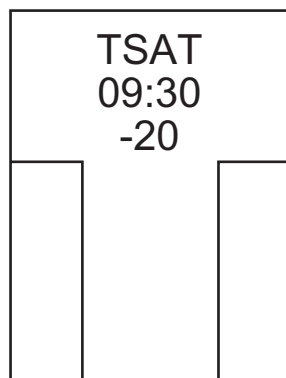

Figure 1

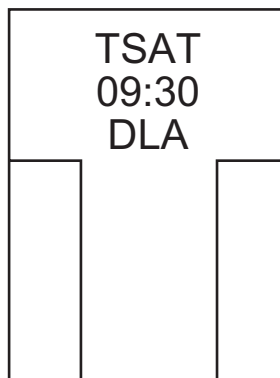

Figure 2

3-2-2-1 When TSAT is revised, it is informed by the message on VDGS.

[Example]

When TSAT on the second row is changed, the third row becomes "CHG" for 3 minutes and starts countdown. (Figure 3)

3-2-2-2 When TSAT is voided, it is displayed on VDGS.

[Example]

When TSAT is voided, the second row becomes "VOID" for 5 minutes. Then All displays go out. (Figure 4)

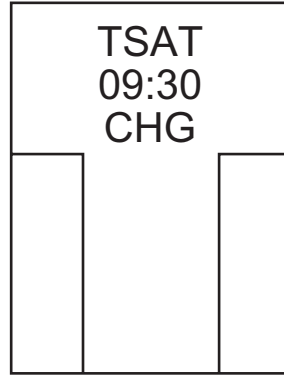

Figure 3

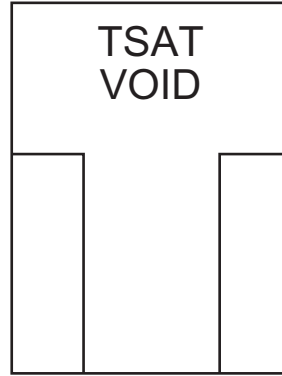

Figure 4

3-2-3 If VDGS is unserviceable or not installed in a parking stand, and TSAT is changed after ATC clearance has been issued, Narita Delivery or Narita Ramp Control informs a new TSAT to an aircraft.

3-3 Validation of TSAT

3-3-1 The aircraft should recognize the TSAT displayed on VDGS as the valid TSAT.

3-3-2 If the VDGS is not installed or unserviceable, an aircraft should recognize the last TSAT notified by Narita Delivery or Narita Ramp Control as the valid TSAT.

3-4 Cancellation

Narita Delivery or Narita Ramp Control notifies the aircraft by voice RTF or data link when TSAT is cancelled.

[Example]

Voice RTF "TSAT CANCELLED"

Data link "TSAT CNL"

3-5 Pushback/Taxi Request

3-5-1 An aircraft should ensure the aircraft is ready for Pushback/Taxi at TSAT after obtained ATC clearance following RJAA AD 2.22 (V) ATC Procedures (2) Departure (A) ATC clearance. Regardless of above, an aircraft is able to request Pushback/Taxi from 3 minutes earlier than TSAT when the aircraft is ready.

3-5-2 If the aircraft cannot achieve TSAT, TOBT should be updated accordingly. If manual input of TOBT cannot be accomplished, the aircraft should request Pushback/Taxi as soon as the aircraft is ready.

3-5-3 An aircraft is able to request Pushback/Taxi if Narita Delivery or Narita Ramp Control informs the TSAT has been cancelled regardless of displayed on VDGS.

3-5-4 Narita Ramp Control may give an instruction of Pushback/Taxi even before the TSAT depending on capacity of ground traffic. For that, the aircraft is requested to monitor the frequency instructed by Narita Delivery after obtaining ATC clearance.

4. Suspension / Resumption of TSAT Operation

In case of suspension / resumption of TSAT Operation, it is announced by NOTAM RJAA and CDM System.

2.3. TAXIING CHART(16R ARRIVALS)

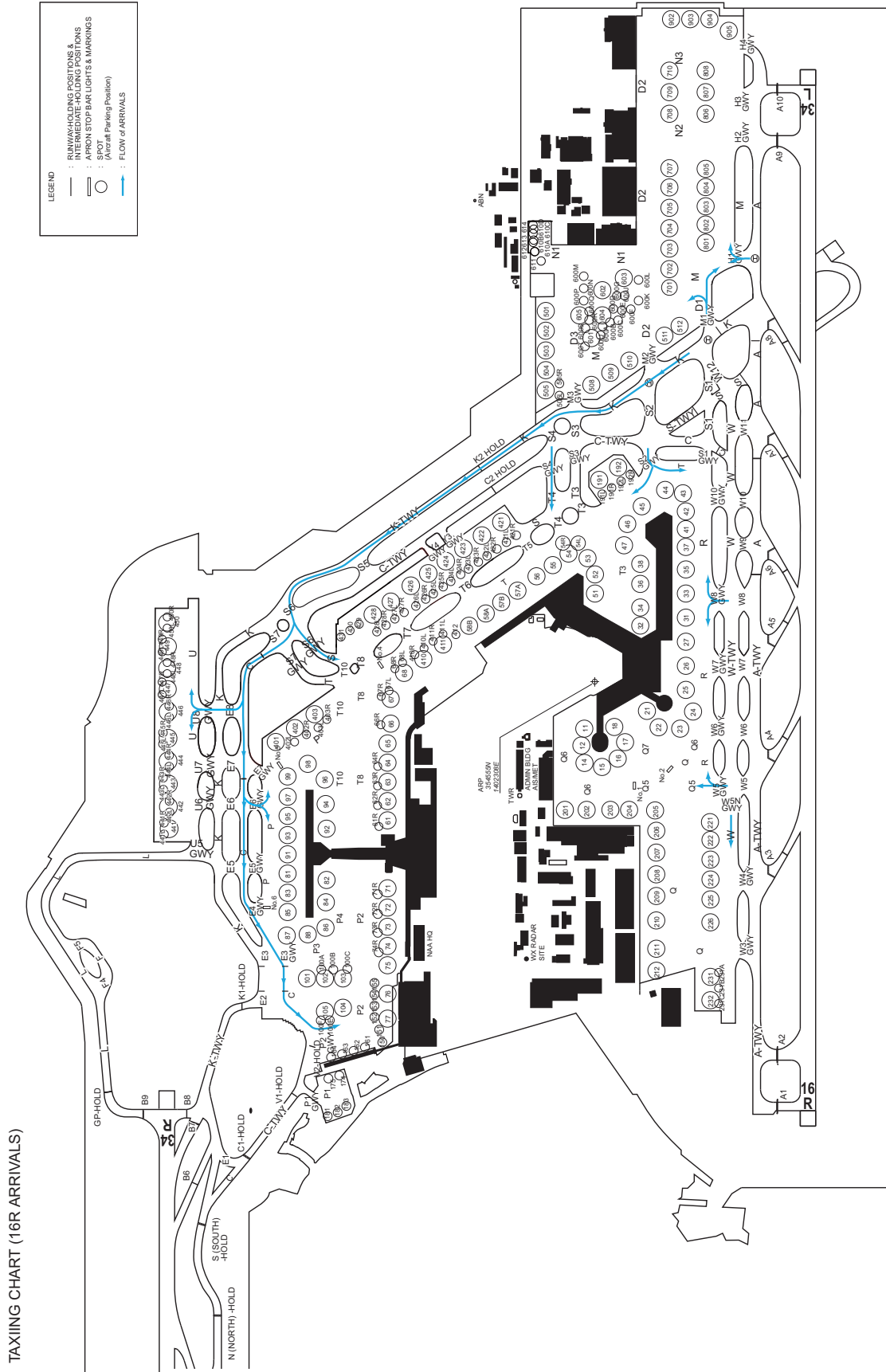

2.4. TAXIING CHART(16R DEPARTURES)

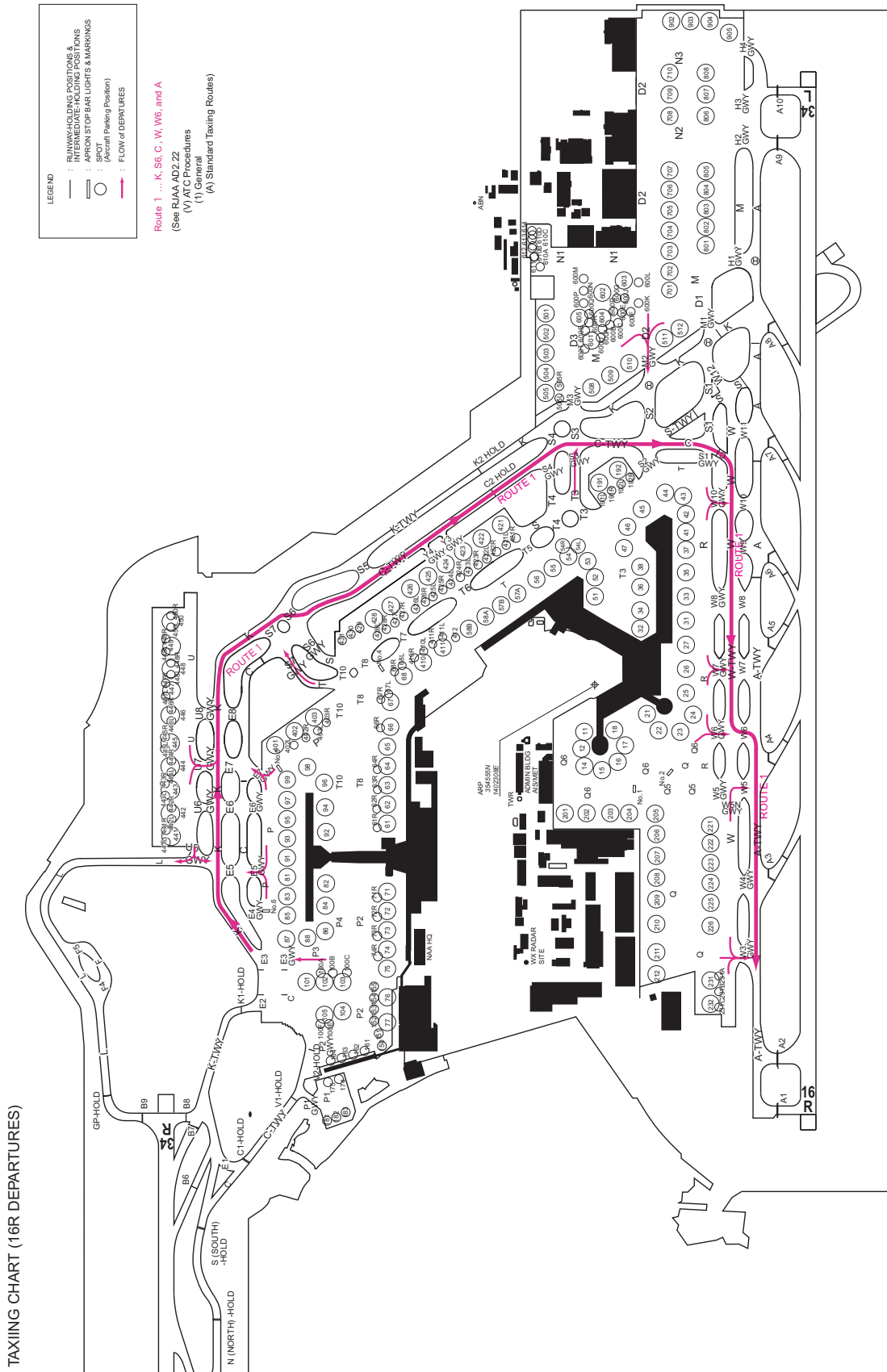

2.5. TAXIING CHART(34L ARRIVALS)

TAXIING CHART (34L ARRIVALS)

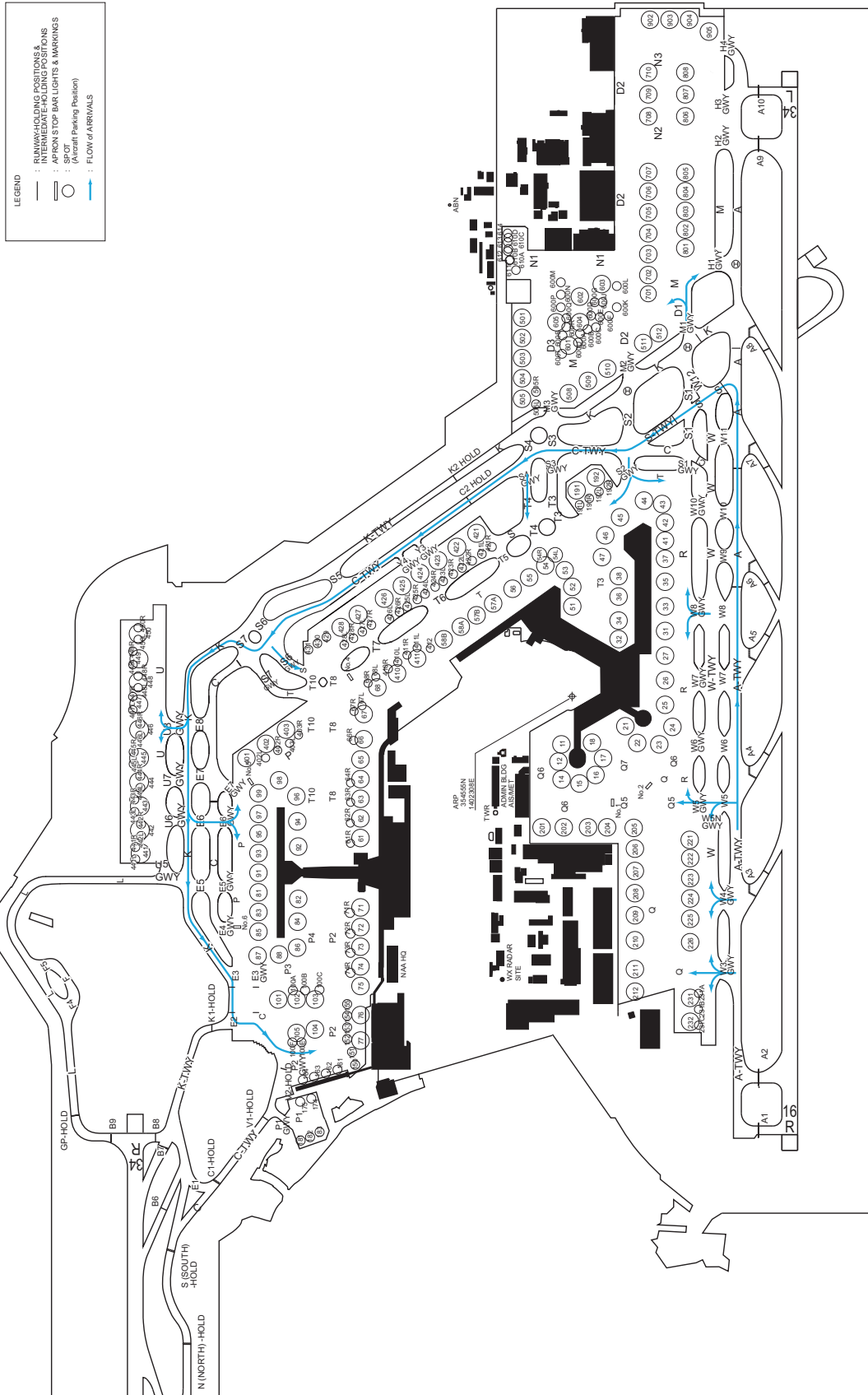

2.6. TAXIING CHART(34L DEPARTURES)

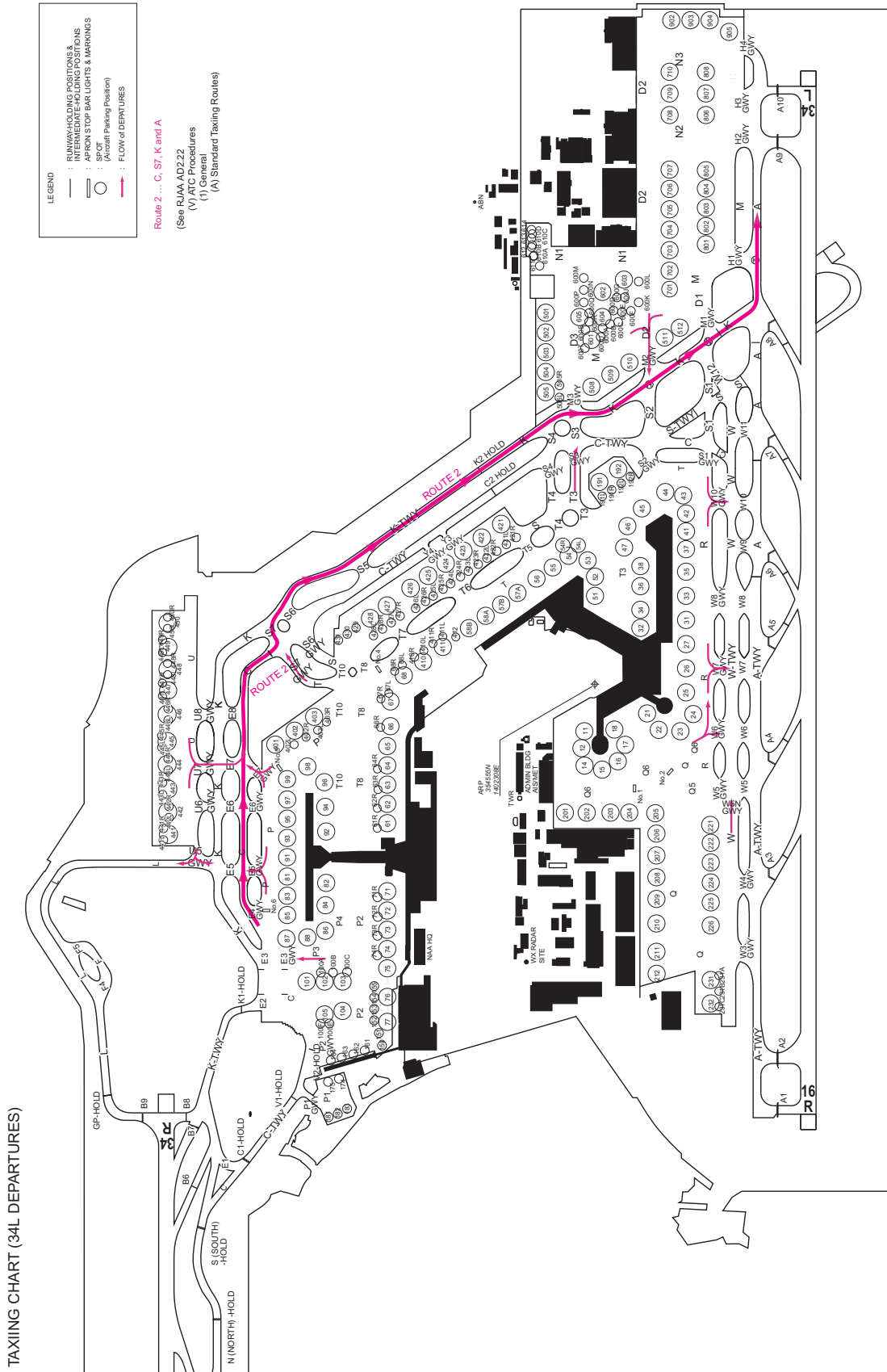

2.8. TAXIING CHART(16L DEPARTURES)

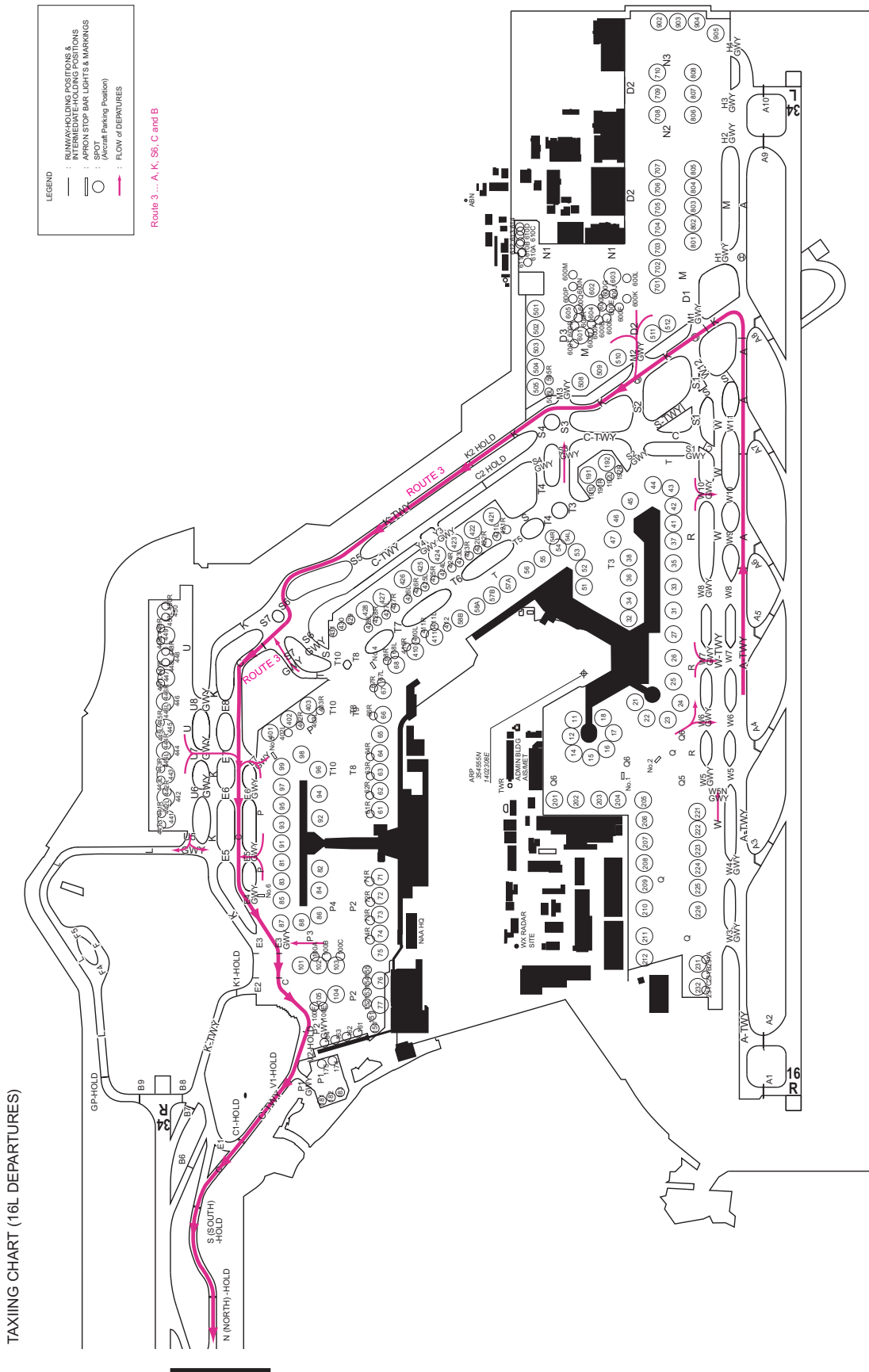

2.9. TAXIING CHART(34R ARRIVALS)

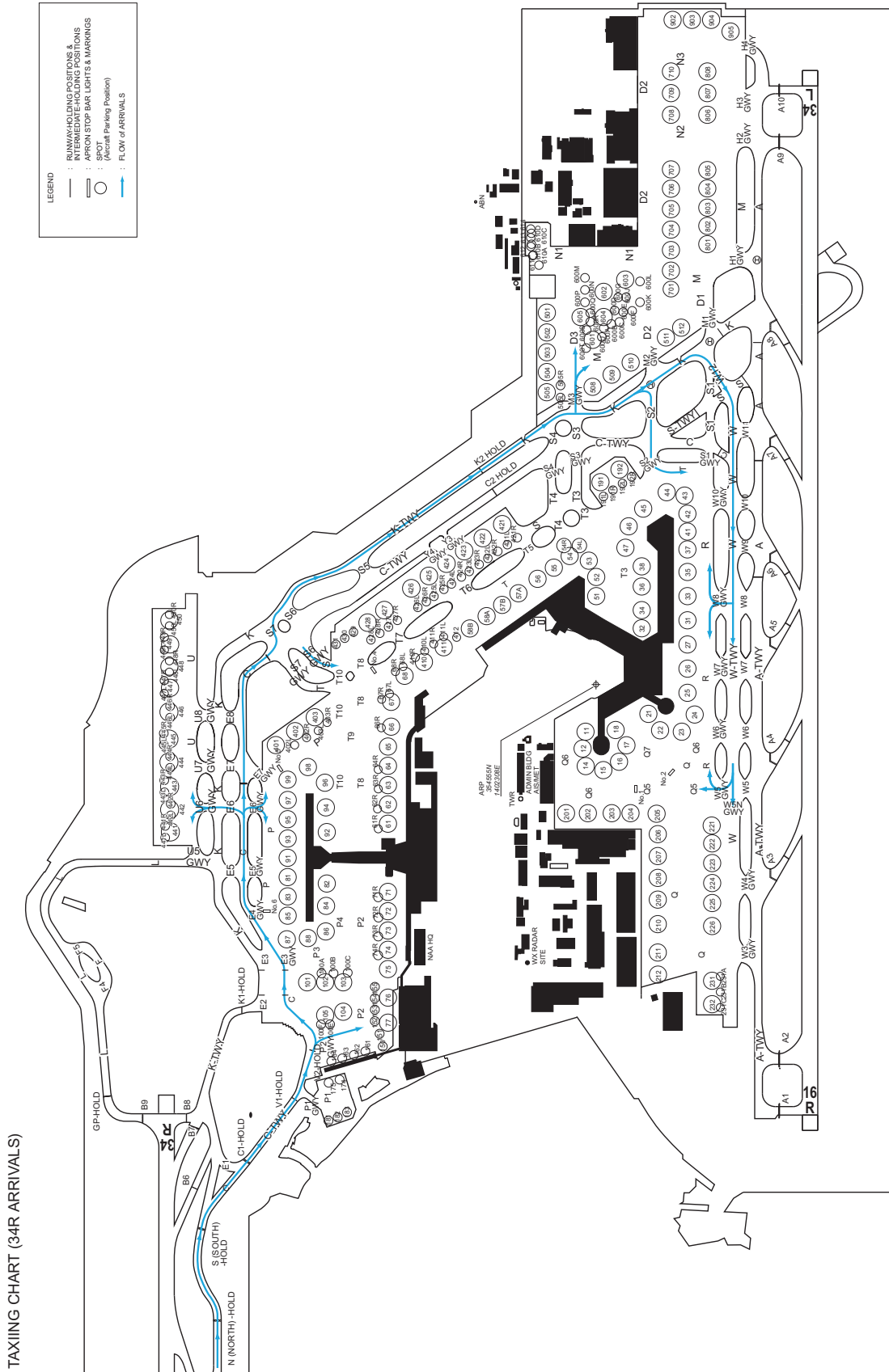

2.10. TAXIING CHART(34R DEPARTURES)

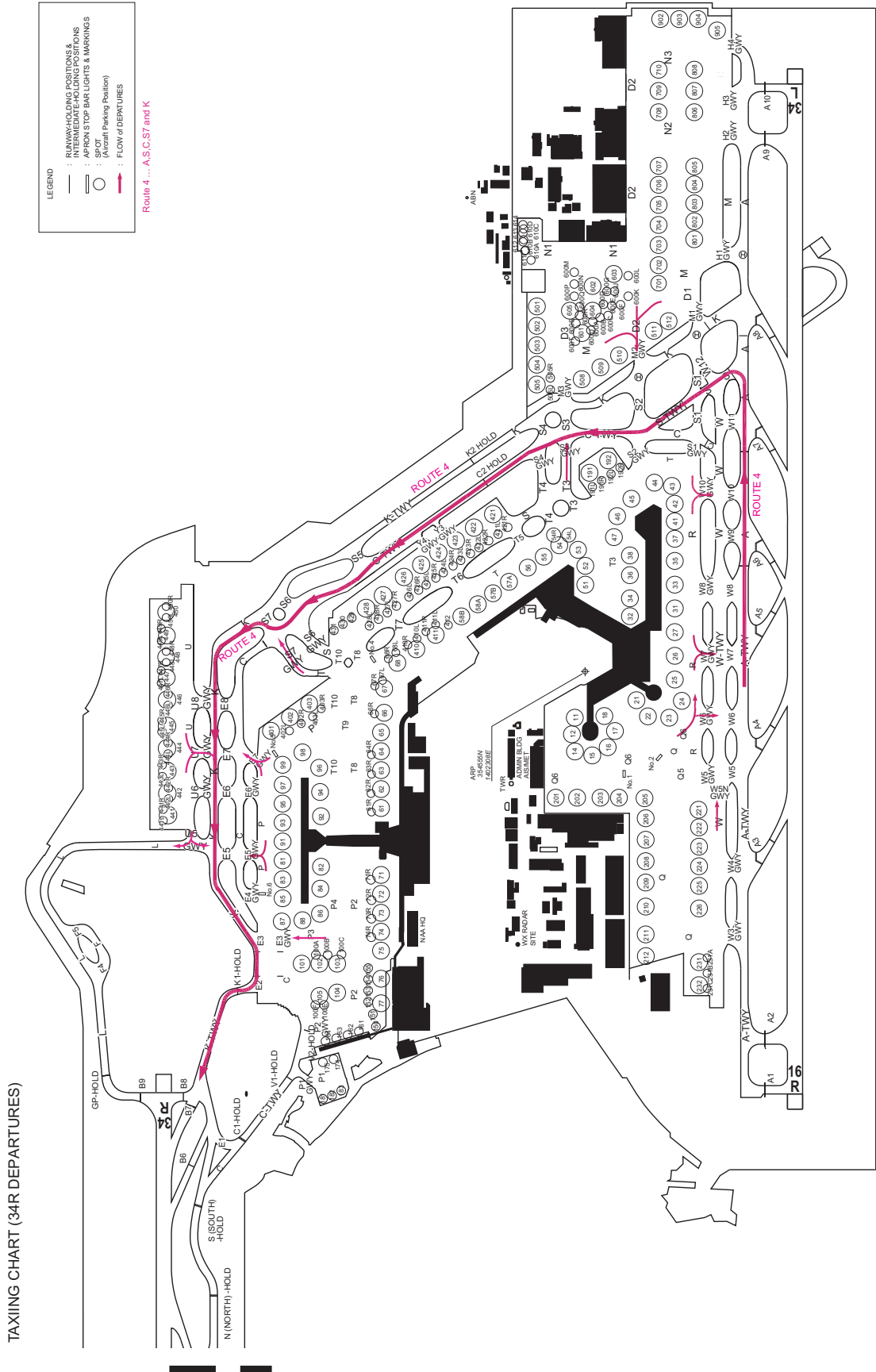

2.11. TAXIING ROUTES FOR CAT II/III OPERATIONS (ARRIVALS)

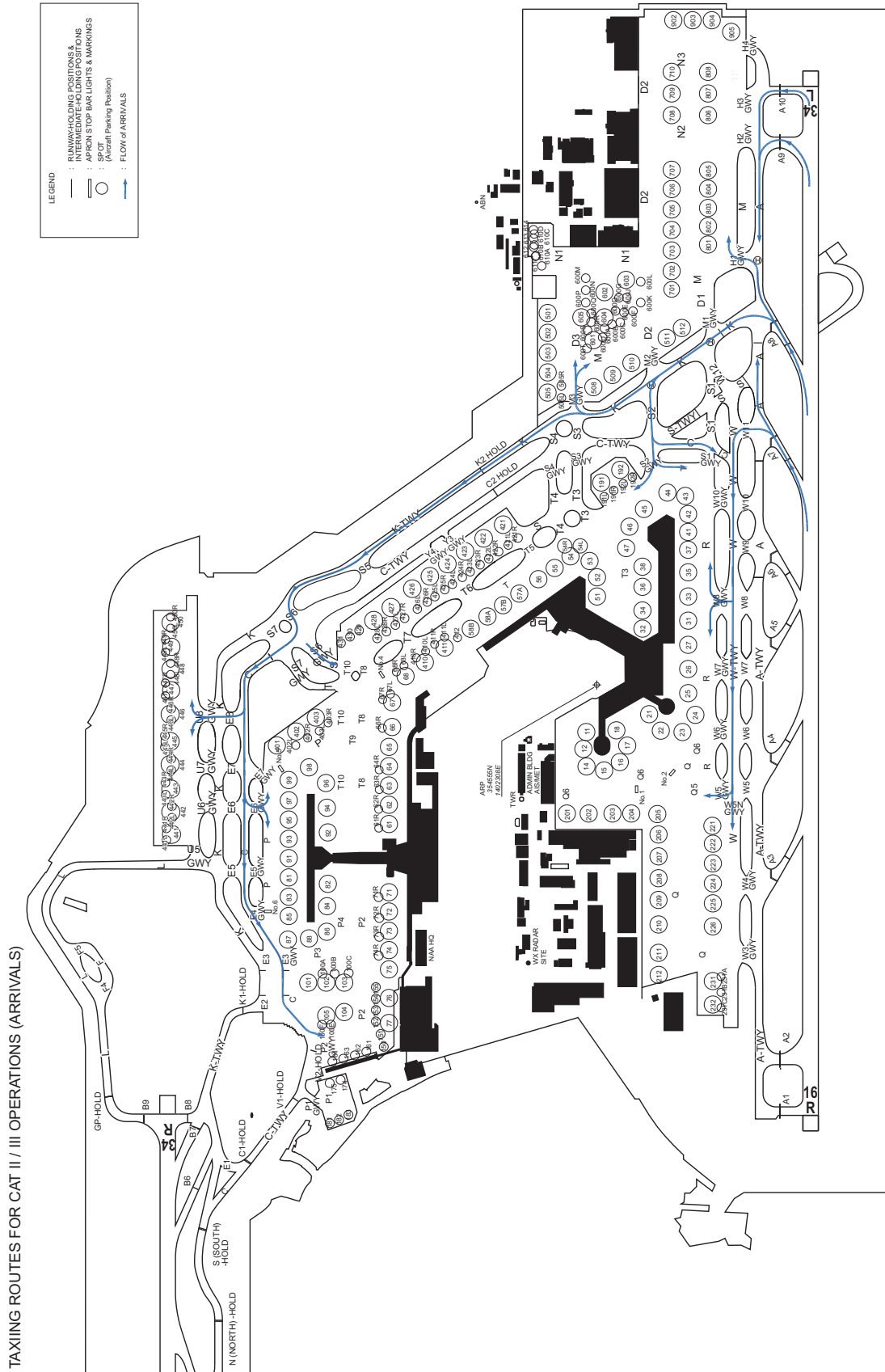

2.12. TAXIING ROUTES FOR CAT II/III OPERATIONS(DEPARTURES)

TAXIING ROUTES FOR CAT II / III OPERATIONS (DEPARTURES)

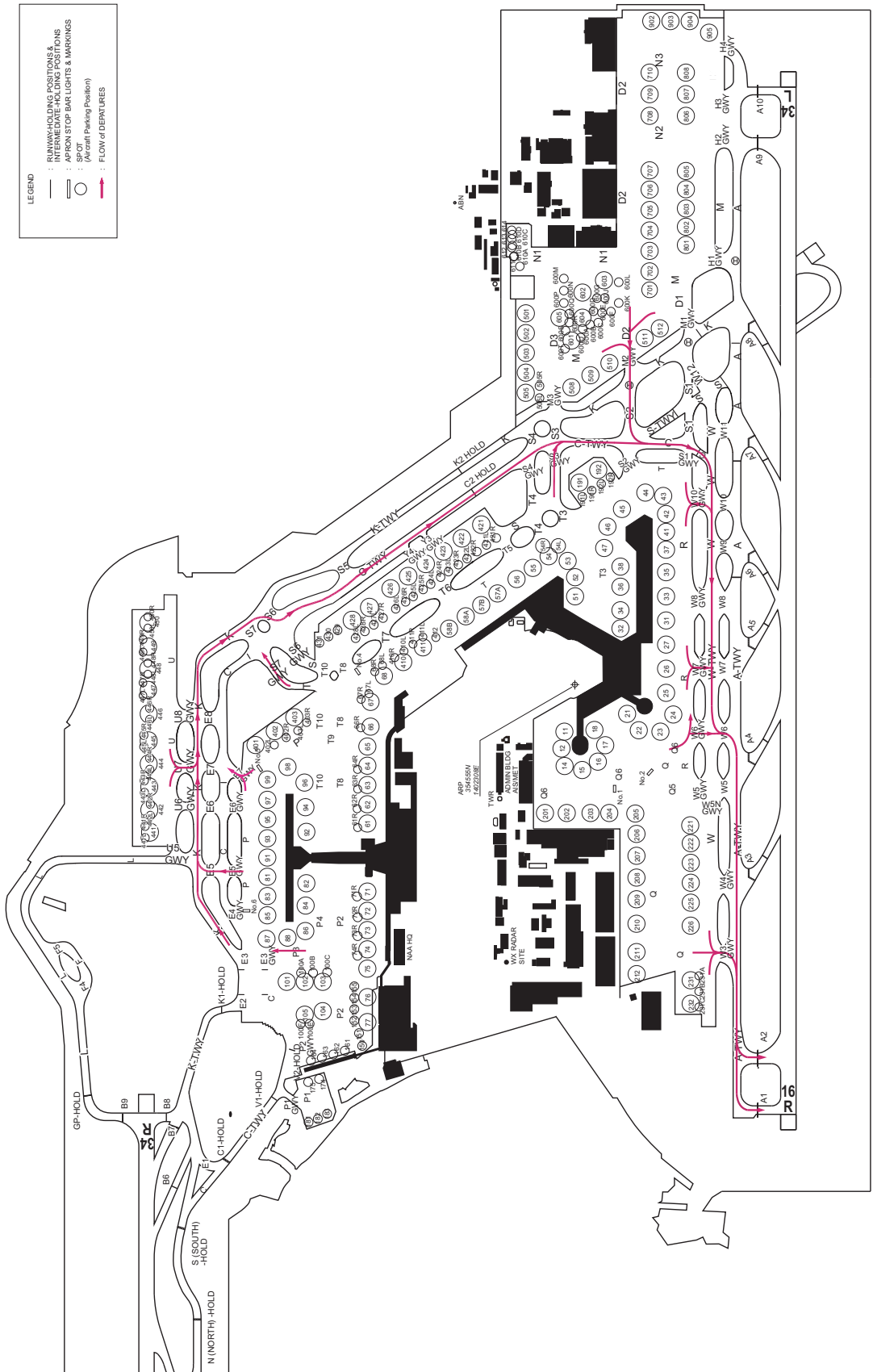

3. Parking area for small aircraft(General aviation)

Nil

4. Parking area for helicopters

Nil

5. Apron - taxiing during winter conditions

Nil

6. Taxiing - limitations

1. Wing tip clearance at the TWY intersection (REF AD1.1 6.8)

Wing tip clearance at the TWY intersection between the aircraft holding at the stop marking on the TWY and the other aircraft taxiing behind it are as follows.

(1) When B738 holding at the stop marking on TWY A2

Wing Span (WS) of aircraft taxiing on A TWY	WS ≤22.6m	22.6m < WS ≤39.6m	WS >39.6m
Wing tip clearance	*A	*B	*C

(2) When B738 holding at the stop marking on TWY A3

Wing Span (WS) of aircraft taxiing on A TWY	WS ≤24m	24m < WS ≤41m	WS >41m
Wing tip clearance	*A	*B	*C

(3) When B738 holding at the stop marking on TWY A4

Wing Span (WS) of aircraft taxiing on A TWY	WS ≤24m	24m < WS ≤41m	WS >41m
Wing tip clearance	*A	*B	*C

(4) When B738 holding at the stop marking on TWY A5

Wing Span (WS) of aircraft taxiing on A TWY	WS ≤24m	24m < WS ≤41m	WS >41m
Wing tip clearance	*A	*B	*C

(5) When B738 holding at the stop marking on TWY A6

Wing Span (WS) of aircraft taxiing on A TWY	WS ≤24m	24m < WS ≤41m	WS >41m
Wing tip clearance	*A	*B	*C

(6) When B738 holding at the stop marking on TWY A7

Wing Span (WS) of aircraft taxiing on A TWY	WS ≤24m	24m < WS ≤41m	WS >41m
Wing tip clearance	*A	*B	*C

(7) When B738 holding at the stop marking on TWY A8			
Wing Span (WS) of aircraft taxiing on A TWY	WS ≤24m	24m < WS ≤41m	WS > 41m
Wing tip clearance	*A	*B	*C
(8) When B738 holding at the stop marking on TWY A9			
Wing Span (WS) of aircraft taxiing on A TWY	WS ≤24m	24m < WS ≤41m	WS > 41m
Wing tip clearance	*A	*B	*C
(9) When B738 holding at the stop marking on TWY B3			
Wing Span (WS) of aircraft taxiing on B TWY	WS ≤ 84m		
Wing tip clearance	*A		
<div style="border: 1px solid black; padding: 5px; margin-top: 10px;"> <p>Legend: *A:wing tip clearance ≥15m *B:6.5m ≤ wing tip clearance <15m *C:wing tip clearance <6.5m</p> </div>			
<p>2. On TWY K between E2 and B8 (See RJAA AD2.24 AD Chart)</p> <ul style="list-style-type: none"> Larger aircraft (such as B747-8, A340-600, B747-400, B777-200LR, B777-300/300ER and B777F) needs to reduce taxiing speed so as to accurately track the center line, as separation between either wing tip and the boundary fence in certain areas of the taxiway is limited to 10.5m. 			
<p>3. MD11/DC10 operations on RWY 16L/34R</p> <ul style="list-style-type: none"> MD11/DC10 needs to taxi with its center engine at idle on TWY B between F3 and K, TWY K between B and E2, in order to prevent jet blast. MD11/DC10 can not enter RWY16L/34R from B8, due to jet blast. 			
<p>4. Restricted taxiways</p> <ul style="list-style-type: none"> While taxiing in the apron area, follow yellow guideline strictly. In addition, taxiing behind the spot 76 and 77, in order to keep clearance between other aircraft or obstacle, the aircraft with wingspan of 60m or longer shall reduce taxiing speed and follow the taxiway center line strictly. All aircraft for runway 34R shall hold at "GP HOLD" on TWY L until receiving further taxi clearance to protect ILS glide slope signal. Only the aircraft with wingspan less than 36m can taxi on TWY P1. 			
<p>5. On Y3-GWY and Y4-GWY</p> <ul style="list-style-type: none"> Only when the aircraft with wingspan less than 36m is approved by ramp control, traffic to C TWY from the apron throughout Y3-GWY and Y4-GWY is permitted. Traffic to the apron from C TWY is not possible. 			
<p>6. Taxilane</p> <ul style="list-style-type: none"> On Taxilane T9, only A380 is permitted to taxi for NR96. (Taxilane T9 marking is blue.) 			

7. School and training flights - technical test flights - use of runways

Nil

8. Helicopter traffic - limitation

Nil

9. Removal of disabled aircraft from runways

Nil

10. Hot Spot

A "HOT SPOT" is a location on an aerodrome movement area with a history or potential risk of collision or runway incursion, and where heightened attention by pilots/drivers is necessary.

HS1

Holding point B8

- Aircraft taxiing to holding point B8 are to make a slight left turn to join the centerline correctly.

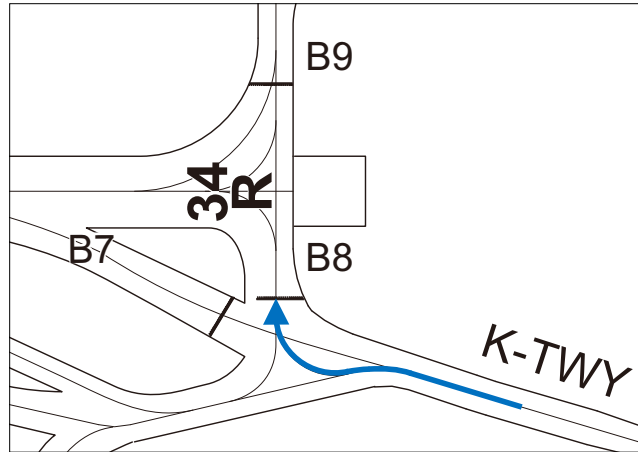

HS2

TWY K between B6 and B8 with slight upslope

- Aircraft exiting RWY16L via B6 sometimes slow down excessively or stop due to the upslope. Manage taxi speed until passing B8 not to block next arrival from exiting RWY16L.

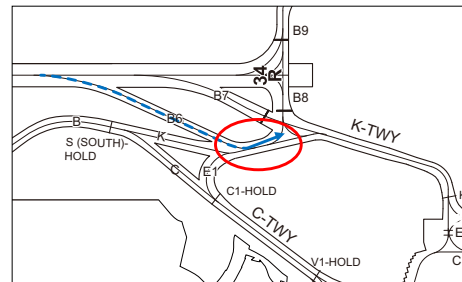

HS3

Complex Intersection area with a convergence of numerous TWYs(K, C, E2, E3, P) and E3GWY.

Numerous cases of entering the wrong TWY occur in this area. In particular, entering K by mistake will cause "head-on" traffic with aircraft vacating from RWY16L.

- Aircraft taxiing to RWY16L via C must not make a right turn at E2 without ATC authorization.

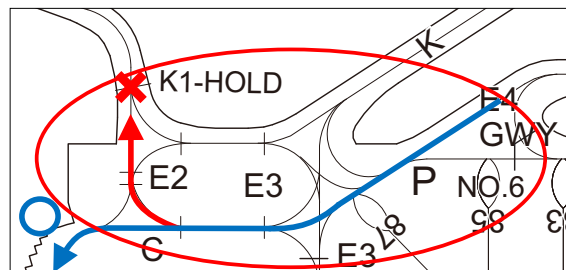

HS4

Complex intersection area with a convergence of numerous TWYs(K, C, S7, S6) and S7GWY/S6GWY.

- Aircraft taxiing via S7 or S6 should pay extra attention to signs and markings to avoid misunderstanding of TWYs.

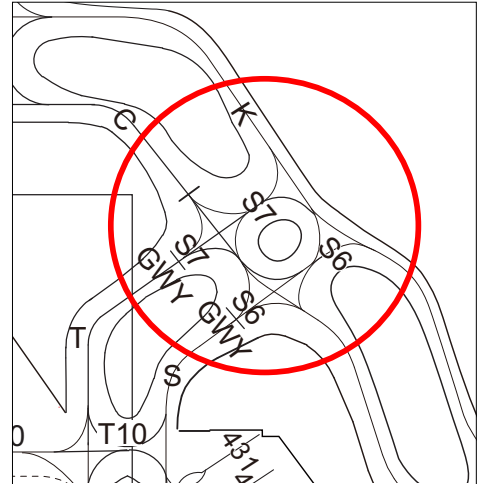

RJAA AD 2.21 NOISE ABATEMENT PROCEDURES

<p>(I) 騒音軽減運航方式</p> <p>(A) 空港周辺地域の航空機騒音を最小にするため、全ての乗員が次に掲げる運航方式、又は、これらの方式と同等の効果がある他の適切な方式を採用するよう強く求めるものである。ただし、これらの方式採用の最終的な権限はそれぞれの機長に委ねられており、機長が安全上の理由により必要と判断する場合は他の方式を採用することができる。</p> <p>1) 離陸について</p> <p>a) 離陸より 1500 フィート AGL(1635 フィート MSL) まで</p> <ul style="list-style-type: none"> －離陸推力 －離陸フラップまたは騒音軽減のための最適フラップ －最大上昇勾配が得られる速度（機体姿勢角の制限範囲内であること） <p>例.V2+10ktまたは1.3Vsのうちいずれか大きい速度での上昇</p> <p>b) 1500 フィート AGL(1635 フィート MSL) において</p> <ul style="list-style-type: none"> －上昇推力を下回らない出力まで減少 － a) と同様なフラップ及び速度 <p>c) 3000 フィート AGL(3135 フィート MSL)、またはそれ以上において</p> <ul style="list-style-type: none"> －運航上昇のための通常速度及びフラップ上げ操作 <p>2) 進入について</p> <p>（ディレイド・フラップ進入及び低フラップ角着陸でのフラップ角設定）</p> <p>a) 次の地点を通過後、最終着陸フラップ角とすること。 IKF から 4DME(RWY16R)、ITM から 4DME(RWY16L)、ITJ から 4DME(RWY34R)、IYQ から 4DME(RWY34L)</p> <p>b) 該当する条件に対して、飛行規程で承認された性能資料に規定されている最小着陸フラップ角を最終着陸フラップ角とすること。</p>	<p>(I) Noise abatement Operating Procedures</p> <p>(A) It is strongly requested of all pilots to apply the following procedures, or any other appropriate procedures which are in effect equivalent to these procedures, in order to minimize public annoyance due to aircraft noise in the vicinity of the airport. The final authority to apply these procedures, however, rests on each pilot in command, and he may use other appropriate procedures if he determines it is necessary in the interest of safety.</p> <p>1) Take-off</p> <p>a) Take-off to 1500ft AGL(1635ft MSL)</p> <ul style="list-style-type: none"> • take-off power • take-off flaps or optimum flap setting for noise reduction. • climb at speed to gain maximum climb angle or as limited by body angle. e.g.V2+10kt or 1.3Vs whichever is greater <p>b) At 1500ft AGL(1635ft MSL)</p> <ul style="list-style-type: none"> • reduce power to not less than climb power • flaps and speed same as in a) <p>c) At 3000ft AGL(3135ft MSL) or above</p> <ul style="list-style-type: none"> • normal speed and flap retraction schedule to enroute climb <p>2) Approach (delayed flap and reduced flap setting)</p> <p>a) Extend final landing flaps after passing 4DME from IKF for RWY16R, 4DME from ITM for RWY16L, 4DME from ITJ for RWY34R or 4DME from IYQ for RWY34L.</p> <p>b) Use, as the final landing flap setting, the minimum certificated landing flaps setting forth in the approved performance information in the Airplane Flight Manual for the applicable conditions.</p>
<p>(B) 優先滑走路方式 なし</p>	<p>(B) Preferential Runways Procedures Nil</p>
<p>(C) 優先飛行経路 なし</p>	<p>(C) Noise Preferential Routes Nil</p>

(II) Other Information

(A)Notwithstanding item (C), for improvement of noise abatement procedures, all aircraft departing from Narita International Airport strictly follow extension of the runway center line until passing 14DME from NRE for RWY16R, 14.0DME from NRE for RWY16L, 6DME from NRE for RWY34L or 5.5DME from NRE for RWY34R.

(B)Aircraft engine ground run-up

In order to minimize noise disturbance in areas adjacent to this Airport, ground run-up of aircraft engine(s) is controlled in accordance with instructions specified in Narita International Airport Administrative Regulations (KUKO KANRI KITEI).

(C)Observance of the flight routes

Unless otherwise instructed by ATC or under unavoidable circumstances, all aircraft arriving at and/or departing from the airport, over the inland area, are requested to follow the routes as prescribed in STARs and SIDs.

(D)Restrictions about the use of auxiliary power unit (APU)

When an aircraft is using an aircraft parking stand with fixed power facilities, APU shall not be used outside the time periods specified below except when specifically acknowledged by the authority as necessary.

- (a) Less than 15 minutes prior to the estimated time of departure.
- (b) The minimum time required for switching over to the fixed power facilities, after arrival at the parking stand.
- (c) For the minimum time required for aircraft maintenance purposes if needed.

NOTE: Spot 11, 12, 14 - 18, 21 - 27, 31 - 38, 41 - 47, 51 - 56, 57A, 57B, 58A, 58B, 61 - 68, 71 - 77, 81 - 88, 91 - 99, 151 - 155, 161 - 164, 174, 175, 201 - 204, 206 - 212, 221-226, 231, 232, 410, 411 are aircraft parking stands with fixed power facilities.

RJAA AD 2.22 FLIGHT PROCEDURES

(I) TAKE OFF MINIMA

	RWY	ACFT CAT	REDL & RCLL		REDL or RCLL or RCL Marking		NIL (DAYTIME ONLY)	
			CEIL-RVR	CEIL-VIS	CEIL-RVR	CEIL-VIS	CEIL-RVR	CEIL-VIS
Multi-Engine ACFT with TKOF ALTN AP FILED	16R	A,B,C	0' - 400m * 0' - 200m **0' - 150m	0' - 400m * 0' - 200m	0' - 400m * 0' - 250m	0' - 400m * 0' - 250m	-	0' - 500m
		D	0' - 400m * 0' - 250m **0' - 200m	0' - 400m * 0' - 250m	0' - 400m * 0' - 300m	0' - 400m * 0' - 300m	-	0' - 500m
	34L	A,B,C,D	0' - 400m	0' - 400m	0' - 400m	0' - 400m	-	0' - 500m
	16L	A,B,C,D	200' - 1600m	200' - 1600m	200' - 1600m	200' - 1600m	-	200' - 1600m
	34R	A,B,C,D	0' - 400m	0' - 400m	0' - 400m	0' - 400m	-	0' - 500m
OTHER	16R 34L 16L 34R	A,B,C,D	AVBL LDG MINIMA					

* APPLICABLE WHEN LVP/LVPD IN FORCE.

** APPLICABLE WHEN LVP/LVPD IN FORCE and MULTIPLE RVRs AVAILABLE.

(II) Lost communication procedures for arrival aircraft under radar navigational guidance

If radio communications with Tokyo Approach/Radar are lost for 1 minute, squawk Mode A/3 Code 7600 and;

1. Contact Narita Tower.
2. If unable, proceed in accordance with visual flight rules.
3. If unable,
 - (1) RWY 34L/R; proceed to GIINA at last assigned altitude or 4,000 feet whichever is higher, and make an instrument approach to RWY34L.
 - (2) RWY 16L/R; proceed to LAKES at last assigned altitude or 6,000 feet whichever is higher, and make an instrument approach to RWY16R.

NOTE: Procedures other than above will be issued when situation required.

(III) Category II / III Operations at Narita International Airport

1. Facilities

The following facilities are available:

Runway 16R
<ul style="list-style-type: none"> • ILS Runway 16R-CAT III • Lighting system Runway 16R-CAT III • RVR by forward-scatter meters (the touchdown zone, the mid-point and stop-end of the runway)

2. Conditions

A. The following systems must be operative:

For ILS RWY 16R approach (CAT II)	For ILS RWY 16R approach (CAT III)
(1) ILS comprising; <ul style="list-style-type: none"> • ILS-LOC 16R with standby transmitter • ILS-GP 16R with standby transmitter (When any standby transmitters unserviceable, downgrade ILS-CAT I.) • IM16R (When IM unserviceable, RA could be used as an alternate method) • ILS-DME 16R 	(1) ILS comprising; <ul style="list-style-type: none"> • ILS-LOC 16R with standby transmitter (including far field monitor) • ILS-GP 16R with standby transmitter (When any standby transmitters or far field monitor unserviceable, downgrade ILS-CAT I.) • ILS-DME 16R
(2) Lighting system comprising; <ul style="list-style-type: none"> • PALS 16R (including side row barrettes) • High INTST REDL • High INTST RTHL • RCLL and RTZL 	(2) Lighting system comprising; <ul style="list-style-type: none"> • PALS 16R (including side row barrettes) • High INTST REDL • High INTST RTHL • RCLL and RTZL
(3) Secondary power supply	(3) Secondary power supply
(4) RVR by forward-scatter meters at the touchdown zone and either (the mid-point or stop-end of the runway).	(4) RVR by forward-scatter meters at the touchdown zone, mid-point and stop-end of the runway.

B. The following information must be currently available:

- a) Surface wind speed and direction
- b) RVR

C. ITEM A and/or B are not met, the relevant information will be notified to the pilots as soon as practicable.

3. Precision Approach Terrain Profile Chart

See RJAA AD2.24

4. Operating Minimum

Approach minima stated in AD2.24(Instrument Approach Chart) are observed.

5. LVP

(1) LVP will be available when the following conditions are met:

- a) Ceiling is at or less than 200ft and/or RVR is at or less than 600m.
- b) Facilities listed 1. above are operational.
- c) ILS Critical Area is protected.

(2) Taxiway available for CAT II / III Operations

a) Exit taxiway: A7 - A10

NOTE: A6 is not available as exit taxiway. (Its taxiway center line lights will be turned off.)

b) Taxi routes as shown in RJAA AD2.20.2.10.TAXIING ROUTES FOR CAT II/III OPERATIONS(ARRIVALS)

c) In order to protect ILS Critical Area, an arrival aircraft may be given following instruction by ATC.

" REPORT OUT OF ILS CRITICAL AREA "

The exit taxiway center line lights are fixed alternate green and yellow inside the ILS Critical Area. If an aircraft is given the above instruction, she is expected to advise the ATC when the exit taxiway center line lights change from alternate green and yellow to steady green.

6. FOLLOW-ME service :

FOLLOW-ME service will be available on request.

7. Approval for CAT II / III Operations

Operations must obtain operational approval from the State of Registry or State of Operator, as appropriate, to conduct CAT II / III Operations.(See GEN1.5)

(IV) LVTO at Narita International Airport

1. Facilities

The following facilities are available:

Runway 16R
<ul style="list-style-type: none">• Lighting system RWY 16R for LVTO• RVR by forward-scatter meters (the touchdown zone, the mid-point and stop-end of the runway)

2. Conditions

A. The following systems must be operative:

For LVTO
(1) Lighting system comprising; <ul style="list-style-type: none">• High INTST REDL• High INTST RENL• RCLL
(2) Secondary power supply

B. The following information must be currently available:

- a) Surface wind speed and direction
- b) RVR or VIS

C. ITEM A and/or B are not met, the relevant information will be notified to the pilots as soon as practicable.

3. Operating Minima

Take-off minima stated in AD2.22 (TAKE-OFF MINIMA) are observed.

4. LVP/LVPD

(1) LVP/LVPD will be available when the following conditions are met:

- a) RVR is at or less than 600m.
- b) Facilities listed 1. above are operational.

(2) Taxiway available for LVTO

- a) Entering taxiway: A1 and A2

NOTE: Stop bar lights on A1 and A2 are controlled individually by ATC.

- b) Taxi routes as shown in RJAA AD2.20.2.11.TAXIING ROUTES FOR CAT II/III OPERATIONS(DEPARTURES)

(V) ATC Procedures

For the purpose of ensuring to provide the aircraft in and out of Narita with more orderly and efficient flow of traffic, aircraft operators are strongly requested to observe prearranged scheduled time and to comply with the following.

(1) General

(A) Standard Taxiing Routes (See RJAA AD2.20)

Unless otherwise required, the standard taxiing routes for Departure are instructed by ATC using route names in the table below.

		Route Name	Routing via
Departure	to RWY16R	ROUTE 1	K, S6, C, W, W6 and A
	to RWY34L	ROUTE 2	C, S7, K and A
	to RWY16L	ROUTE 3	A, K, S6, C and B
	to RWY34R	ROUTE 4	A, S, C, S7 and K

NOTE: Alternate routing may be instructed by ATC as required.

(2) Departure

(A) ATC clearance

ATC clearance will be obtained by "Voice radiotelephone (Voice RTF)" or "Departure Clearance by data link (DCL)".

Show in detail below (a) or (b).

CLEARANCE FLOW	(a) Voice RTF	(b) DCL
REQUEST CLEARANCE	Call Narita Delivery (121.9) at 15 minutes before starting engines, with the following information. (1) Call sign (2) Destination (3) Proposed flight level (4) Parking position (spot number)	Refer to ENR 1.5.4.1 (Operation for Departure Clearance by data link (DCL)) - Send RCD message at 15 minutes before starting engines. - Monitor Narita Delivery (121.9). NOTE: - Start monitoring Narita Delivery (121.9) once RCD message is sent. In case coordination is required, Narita Delivery calls the pilot on Voice RTF.
OBTAIN CLEARANCE	Clearance will be delivered on Voice RTF or DCL as soon as possible after coordination with TOKYO ACC. NOTE: - Clearance to specific aircraft will be deferred when coordination is not completed. If ATC clearance is not received in spite of being ready to start engines, the pilot shall inform Narita Delivery (121.9).	
CALL READY	Call Narita Delivery (121.9) when ready to start engines. Regardless of clearance source, pilots shall report ready to start engines (=doors are closed, boarding bridge removed, push-back vehicle connected.) to Narita Delivery (121.9) NOTE: - ATC will give different frequency (Narita Delivery 121.65 or Narita Ramp Control 121.6MHz/121.75MHz/118.15MHz) to call ready to start engines if the situation requires.	
START ENGINES	- Delay information will be given if the situation requires - Contact Narita Ramp Control for approval to start engines ONLY WHEN instructed either Voice RTF or DCL by ATC	

(B) Intersection departure

The remaining runway length for intersection departures are as follows.

Runway	Taxiway	Remaining runway length*
34L	A9	3,630m (11,930 feet)
16R	A2	3,610m (11,870 feet)
34R	B6	1,860m (6,100feet)
	B7	2,100m (6,890feet)
16L	B2	2,030m (6,660feet)
	B3	2,150m (7,050feet)
	B4	1,740m (5,710feet)

*Rounded down to the nearest 10m (10ft) from the measurement between the point where TWY CL meets RWY CL and RWY THR.

- (C) Pilot should ensure that they are able to follow the clearance to the take-off position or the take-off clearance without delay to reduce runway occupancy time. Cockpit check should be completed prior to line-up and checks requiring completion on the RWY should be kept to a minimum. If unable to do so, notify to Narita Tower.

(3) Arrival

- (A) Aircraft on final approach and in the control zone are recommended to turn the landing lights on.

(B) Speedy Turn-Off Procedure

- (a) For purposes of reducing runway occupancy time, pilots in their approach/landing briefing should plan on a specific exit taxiway and after landing, pilots should vacate the runway without delay, unless the use of another exit taxiway is assigned by ATC or unless the safety of the aircraft is jeopardized.
- (b) The exit taxiways, as a rule, which arriving aircraft should plan to use for vacating the runway, are listed below.

Runway	Taxiway	Distance from threshold(m/ft)	Remarks
34L	A5	1,800m(5,900feet)	BTCL
	A4	2,250m(7,380feet)	BTCL
16R	A6	1,800m(5,900feet)	BTCL
	A7	2,250m(7,380feet)	BTCL
34R	B4	1,740m(5,700feet)	BTCL
	B2	2,030m(6,660feet)	NONE
16L	B6	1,860m(6,100feet)	BTCL
	B7	2,100m(6,890feet)	NONE

Remarks :Brighter Taxiway Center line Lights (BTCL) Installation

For purposes of assisting the speedy turn-off, the intensity of the taxiway center line lights listed above will be brighter than that of other taxiways to improve the recognition of these locations.

Those lights are also lighted during daytime VMC to clearly indicate the exit taxiways, however those lights may be turned off or may not be brighter due to other operational requirements.

- (c) Should pilots plan to use other exit taxiways other than those listed above, where possible, pilots should inform ATC accordingly.

However, ATC may not be able to assign the exit taxiway as requested due to traffic conditions or any other reason.

(VI) SIMULTANEOUS PARALLEL INDEPENDENT DEPARTURES (SPID)

1. Applicable aircraft for SPID

SPID will be conducted for the aircraft flying RNAV1 SID on the adjacent runway complexes (RWY34L/34R or RWY16L/16R).

Note: For RWY34R, pilots are required to set the appropriate speed to avoid unintentional deviations (ex. ROUTE DISCONTINUITY on FMS*) especially under strong wind conditions aloft.

* FMS: Flight Management System

2. Conditions

SPID, where radar separation minima between aircraft on the adjacent straight-out departure courses are not prescribed, will be conducted when the following conditions are met. However, SPID shall not be applied under certain adverse weather conditions which might affect safe operations (e.g. windshear, strong crosswind, severe weather activity such as thunderstorms).

- (1) Departure No Transgression Zone (DNTZ) 610m wide is established equidistant between initial straight-out segments of departure courses and is depicted on the radar display.
- (2) Radar and appropriate frequencies are operating normally.

3. Information of SPID

Aircraft shall be advised that SPID are in force. This information may be provided through ATIS broadcasts.

“Simultaneous parallel departures (from runway [number] left and right are) in progress.”

4. FMS Validation and Phraseologies

- (1) Pilots shall verify that the required RNAV path to the initial waypoint on the loaded SID is correctly associated with the departure runway. (see Table 1)

The following phraseologies require pilots’ action to validate correct programming of the departure runway and departure procedures in FMS prior to take-off.

“VERIFY INITIAL WAYPOINT [initial fix].”

“RNAV TO [initial fix], RUNWAY [number], CLEARED FOR TAKE OFF.”

Table 1: The initial fixes on RNAV SIDs associated with runway.

RUNWAY	INITIAL FIX	Departure Frequency*
34L	ARIES(ASTRA**)	124.2MHz
34R	BOXER	119.6MHz
16L	BEAMS	119.6MHz
16R	ASPEN	124.2MHz

* Unless otherwise instructed by ATC, a departure frequency is assigned for each runway.

* Do not change a frequency to the Departure Frequency until instructed by Tower.

** Only for PEDLA [number] DEPARTURE

- (2) If the loaded SID in FMS does not satisfy the initial-waypoint verification, pilots shall immediately advise ATC and shall not take-off until alternative instructions are received.

5. Track monitoring

Track monitoring for SPID shall be provided as follows;

- (1) Track monitoring controllers for each runway provide an initial departure control to ensure aircraft does not deviate from the required path within the initial straight-out climb.

Note: Parallel RNAV departures must not encroach on the airspace between extended parallel runway centerlines without specific ATC clearance. Manually intervene if necessary to stay on track to avoid transgressing in the direction of a parallel track.

- (2) Aircraft observed to continue on a track which will penetrate DNTZ will be instructed a heading to avoid aircraft on the adjacent departure course. If a deviating aircraft fails to respond to such instructions or is observed to penetrating DNTZ, the aircraft on the adjacent departure course shall be instructed to avoid the deviating aircraft.

“TRAFFIC ALERT, [repeat aircraft identification], TURN LEFT/RIGHT IMMEDIATELY, HEADING [number], (CLIMB AND) MAINTAIN [altitude].”

6. Response to "TRAFFIC ALERT"

All breakouts in response to ATC's instructions shall be accomplished quickly. These instructions will be issued on TOWER FREQUENCY or DEPARTURE FREQUENCY when situation required.

(VII) SPECIAL VFR FLIGHT ROUTE FOR HELICOPTER

Special VFR flight route for helicopter in the NARITA CONTROL ZONE (See Visual REP chart)
SHISUI-ROUTE: SHISUI-TOMISATO-LUNCH

RJAA AD 2.23 ADDITIONAL INFORMATION

1. HELIPAD

- (1) Three helipads on TWY intersections of TWY K and S2, K and S1, A and H1. (Refer to the Aerodrome Chart)
- (2) Helipad WEST located on the west side of RWY34L. (Refer to the Aerodrome Chart)

2. Scheduled maintenance hours on the runway

Scheduled runway unserviceability due to runway and facilities maintenance. (See NOTAM RJAA)

3. Vehicle traffic lines

White broken lines in the apron areas (15 centimeter wide, 3 meter long, 2 meter apart).

4. Obstruction

There are trees penetrating above the approach surface at the area about 400m before the Runway 34R threshold. Refer to attachment for detailed description and illustration of these obstructions and their relative positions to the obstruction lights. (See RJAA AD2.24)

RJAA AD 2.24 CHARTS RELATED TO AN AERODROME

Aerodrome Chart-1
Aerodrome Chart-2
Aerodrome Ground Movement Chart
Aerodrome Obstacle Chart-ICAO type A (RWY16R/34L)
Aerodrome Obstacle Chart-ICAO type A (RWY16L/34R)
Aerodrome Obstacle Chart-ICAO type B
Precision Approach Terrain Chart
Standard Departure Chart - Instrument (SAKURA)
Standard Departure Chart - Instrument (AKAGI)
Standard Departure Chart - Instrument (SUNNS)
Standard Departure Chart - Instrument (TETRA-RNAV)
Standard Departure Chart - Instrument (REDEK-RNAV)
Standard Departure Chart - Instrument (PIGOK-RNAV)
Standard Departure Chart - Instrument (GULBO-RNAV)
Standard Departure Chart - Instrument (BORLO-RNAV)
Standard Departure Chart - Instrument (PEDLA-RNAV)
Standard Departure Chart - Instrument (OLVAN-RNAV)
Standard Arrival Chart - Instrument (SOUTH)
Standard Arrival Chart - Instrument (NORTH)
Standard Arrival Chart - Instrument (RUTAS E/T-RNAV)
Standard Arrival Chart - Instrument (SWAMP E/T-RNAV)
Standard Arrival Chart - Instrument (SUPOK E/T-RNAV)
Standard Arrival Chart - Instrument (LUBLA E/T-RNAV)
Standard Arrival Chart - Instrument (RUTAS G/N-RNAV)
Standard Arrival Chart - Instrument (SWAMP G/N-RNAV)
Standard Arrival Chart - Instrument (SUPOK G/N-RNAV)
Standard Arrival Chart - Instrument (LUBLA G/N-RNAV)
Instrument Approach Chart (ILS RWY34L)
Instrument Approach Chart (LOC RWY34L)
Instrument Approach Chart (VOR RWY34L)
Instrument Approach Chart (ILS Z RWY34R)
Instrument Approach Chart (ILS Y or LOC RWY34R)
Instrument Approach Chart (RNP RWY34R)
Instrument Approach Chart (ILS Z RWY16R(CAT II & III))
Instrument Approach Chart (ILS Y or LOC RWY16R(CAT II & III))
Instrument Approach Chart (VOR RWY16R)
Instrument Approach Chart (ILS Z RWY16L)
Instrument Approach Chart (ILS Y or LOC Y RWY16L)
Instrument Approach Chart (ILS X or LOC X RWY16L)
Instrument Approach Chart (RNP RWY16L)
Other Chart (HOLDING PATTERN)
Other Chart (HOLDING PATTERN-RNAV)
Other Chart (Visual REP)
Other Chart (LDG CHART)
Other Chart (LDG CHART / Trees)
Other Chart (MVA CHART)

AERODROME CHART

NARITA INTERNATIONAL AIRPORT
ELEV 41m(134.5ft)ARP

HS
HS: HOT SPOT / see RJAA AD2.20

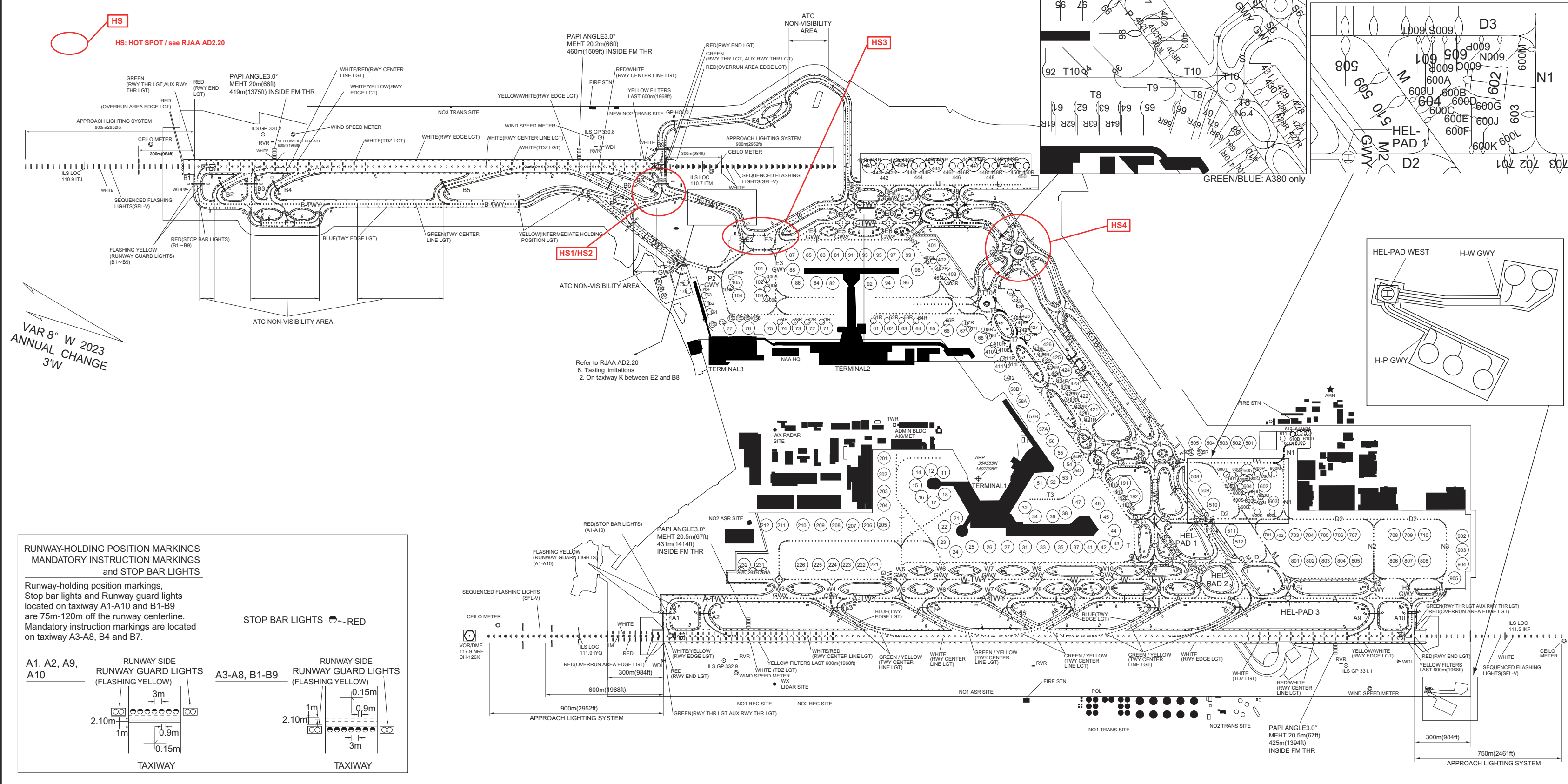

VAR 8° W 2023
ANNUAL CHANGE
3'W

HS1/HS2

HS3

HS4

Refer to RJAA AD2.20
6. Taxing limitations
2. On taxiway K between E2 and B8

**RUNWAY-HOLDING POSITION MARKINGS
MANDATORY INSTRUCTION MARKINGS
and STOP BAR LIGHTS**

Runway-holding position markings, Stop bar lights and Runway guard lights located on taxiway A1-A10 and B1-B9 are 75m-120m off the runway centerline. Mandatory instruction markings are located on taxiway A3-A8, B4 and B7.

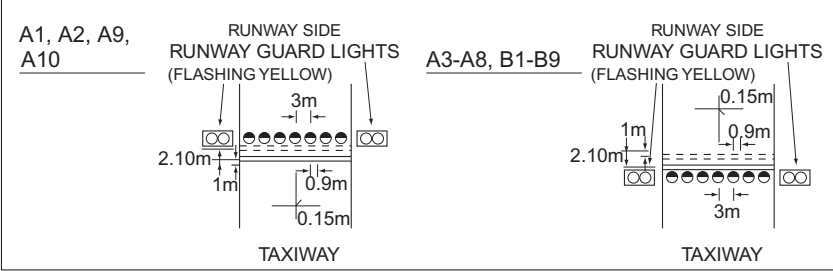

CHANGE : HOT SPOT added.

CHANGE : Ramp FREQ(118.15) added.

NARITA INTL AP
ELEV 41m(134.5ft)ARP

ATIS	128.25
DLVRY	121.9
GND	121.95 121.85
Ramp	121.6 121.75
TWR	118.15 118.35

VAR 8°W
2023 APR ANNUAL
CHANGE 3W

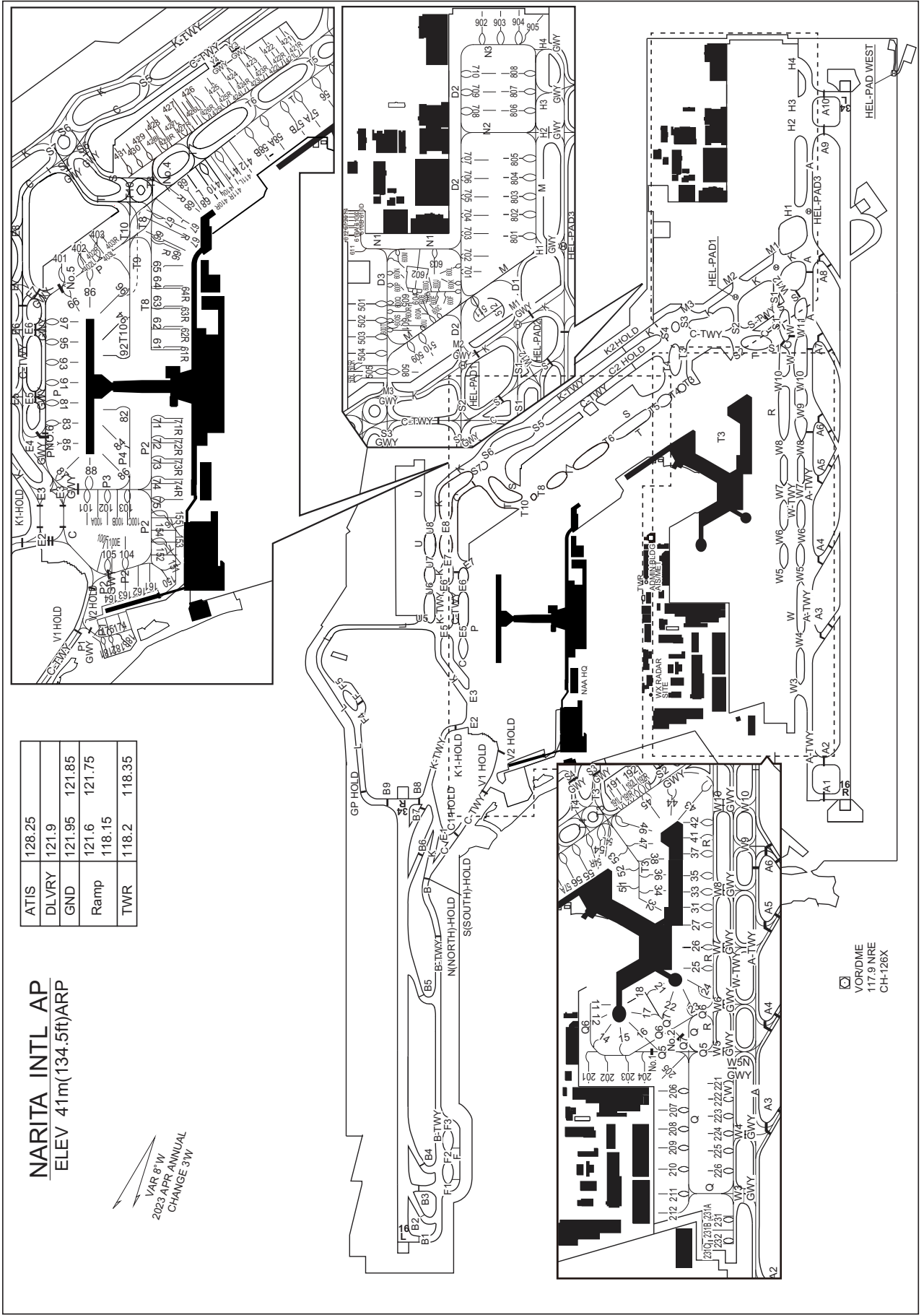

INTENTIONALLY LEFT BLANK

AERODROME OBSTRUCTION CHART-ICAO
TYPE A (OPERATING LIMITATIONS)

DIMENSIONS AND ELEVATIONS IN FEET BEARINGS ARE MAGNETIC

MAGNETIC VARIATION 8° W-FEB 2023

NARITA INTERNATIONAL AIRPORT
RWY : 16R/34L

DECLARED DISTANCES	
RWY 16R	RWY 34L
4000m TAKE-OFF RUN AVAILABLE	4000m
4000m TAKE-OFF DISTANCE AVAILABLE	4000m
4000m ACCELERATE STOP DISTANCE AVAILABLE	4000m
4000m LANDING DISTANCE AVAILABLE	4000m

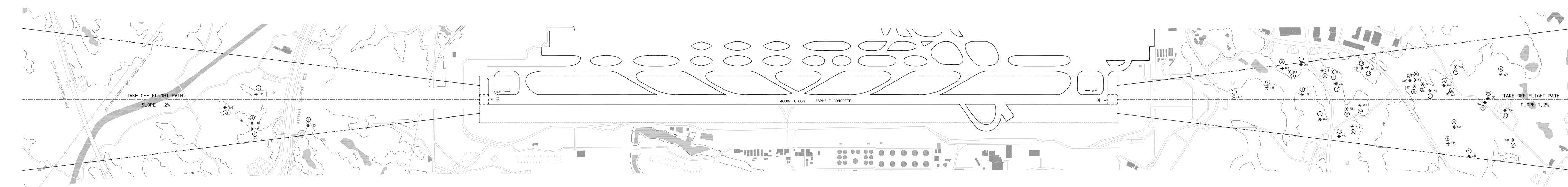
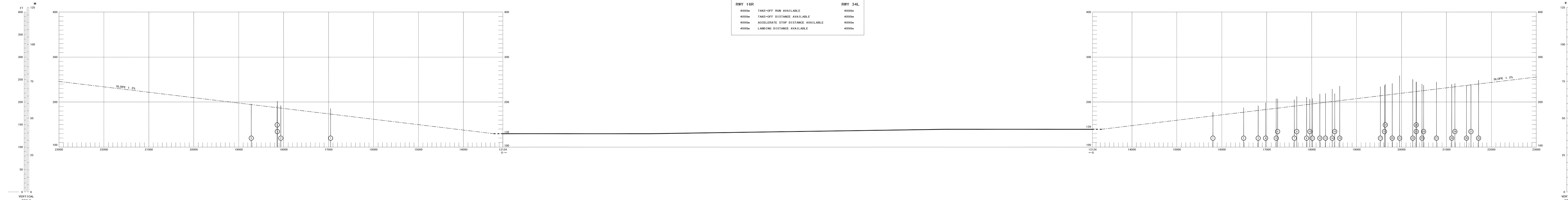

LEGEND	AMENDMENT RECORD		
	No.	DATE	ENTERED BY
① IDENTIFICATION NUMBER			
○ POLE, TOWER, SPIRE, ANTENNA, ETC.			
* TREE			
— RAIL ROAD			
— TRANSMISSION LINE OR OVERHEAD CABLE			
△ TRANSMISSION POINTS			
☆ AERONAUTICAL GROUND LIGHT			

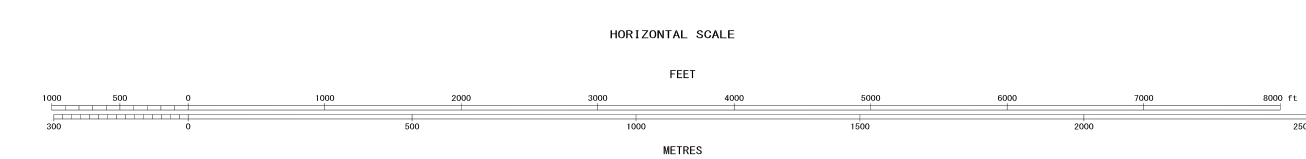

CHANGE Update

AERODROME OBSTRUCTION CHART-ICAO
TYPE A (OPERATING LIMITATIONS)

DIMENSIONS AND ELEVATIONS IN FEET BEARINGS ARE MAGNETIC

MAGNETIC VARIATION 8° W-FEB 2023

NARITA INTERNATIONAL AIRPORT
RWY : 16L/34R

DECLARED DISTANCES	
RWY 16L	RWY 34R
2500m TAKE-OFF RUN AVAILABLE	2500m
2500m TAKE-OFF DISTANCE AVAILABLE	2500m
2500m ACCELERATE STOP DISTANCE AVAILABLE	2500m
2500m LANDING DISTANCE AVAILABLE	2500m

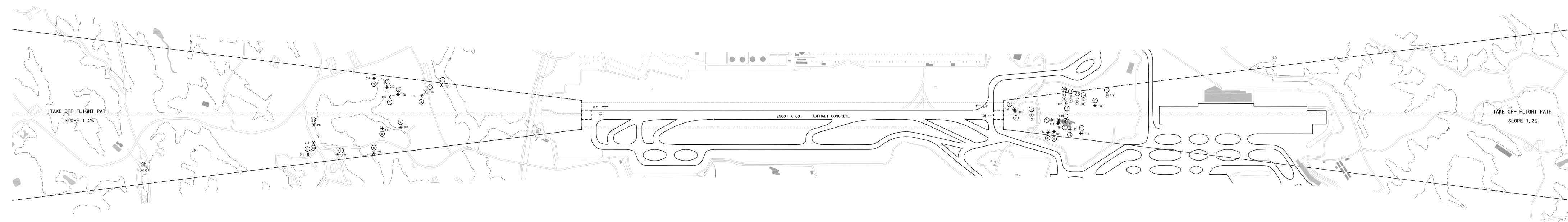
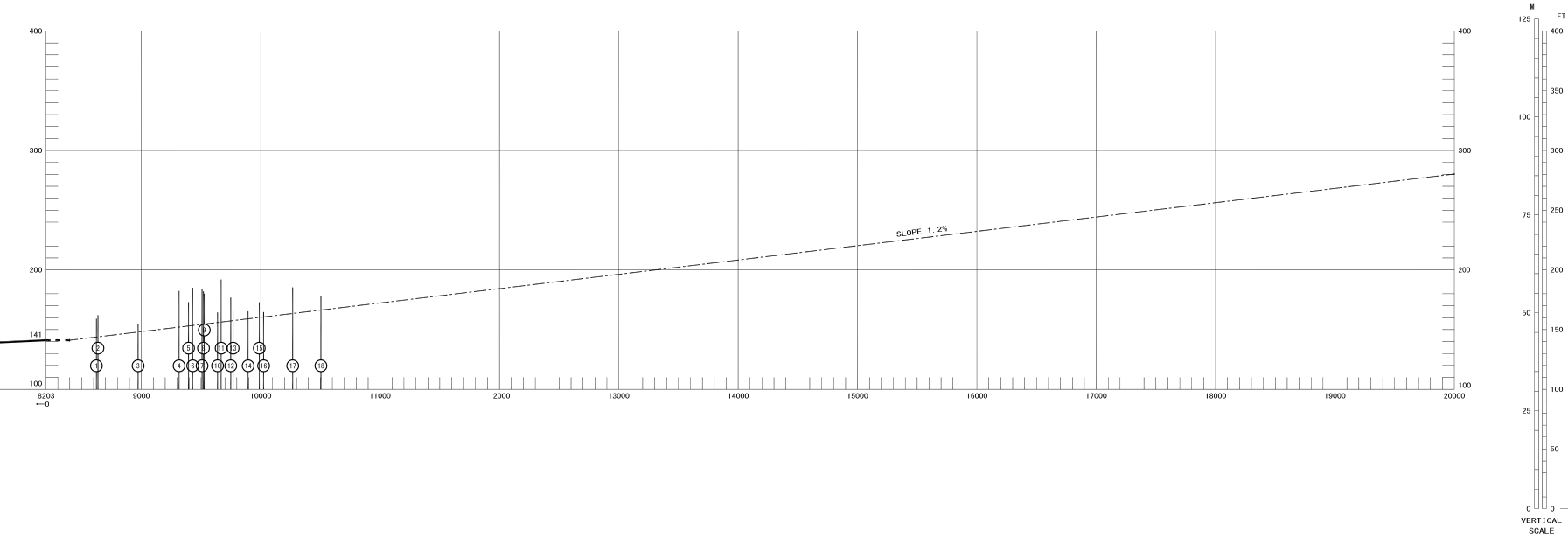
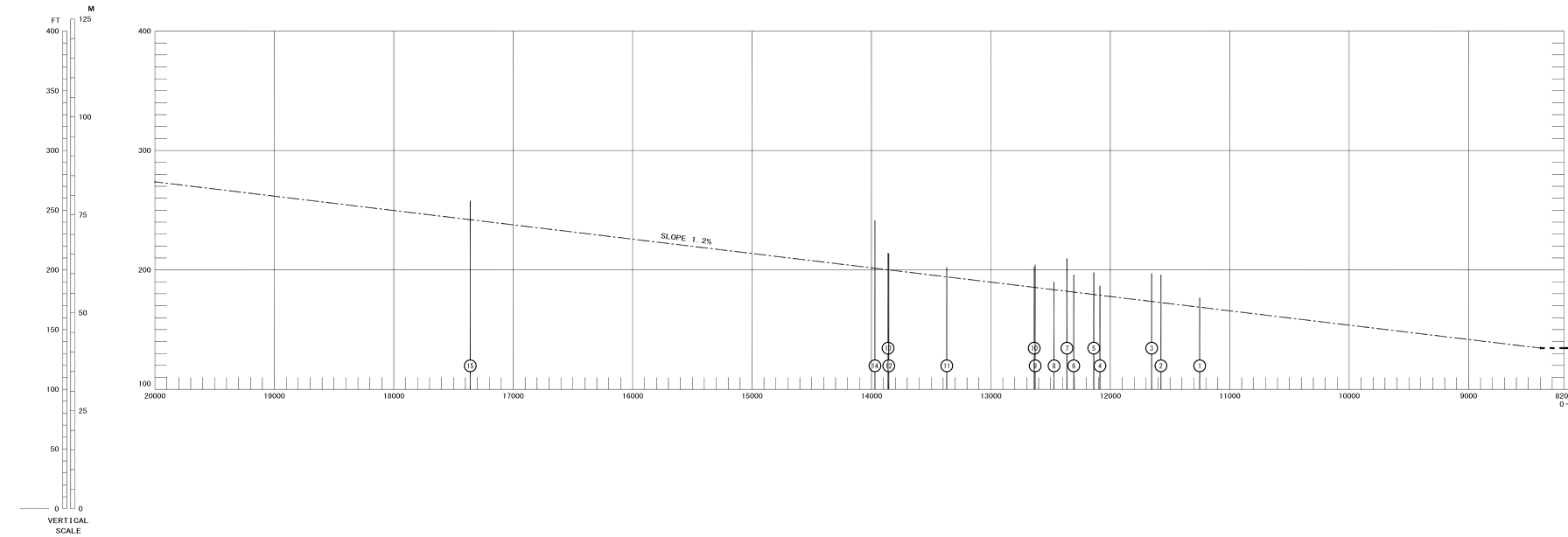

LEGEND	
①	IDENTIFICATION NUMBER
⊙	POLE, TOWER, SPINE, ANTENNA, ETC
*	TREE
—	RAIL ROAD
—	TRANSMISSION LINE OR OVERHEAD CABLE
△	TRIANGULATION POINTS
☆	AERONAUTICAL GROUND LIGHT
—	LEVEE
—	RIVER

AMENDMENT RECORD		
NO	DATE	ENTERED BY

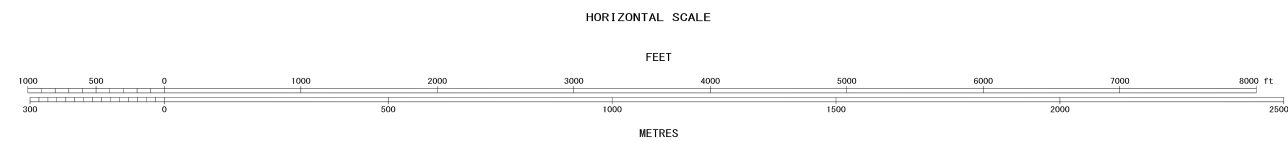

CHANGE Update

AERODROME OBSTRUCTION CHART-ICAO
TYPE B

DIMENSIONS AND ELEVATION IN FEET BEARINGS ARE MAGNETIC

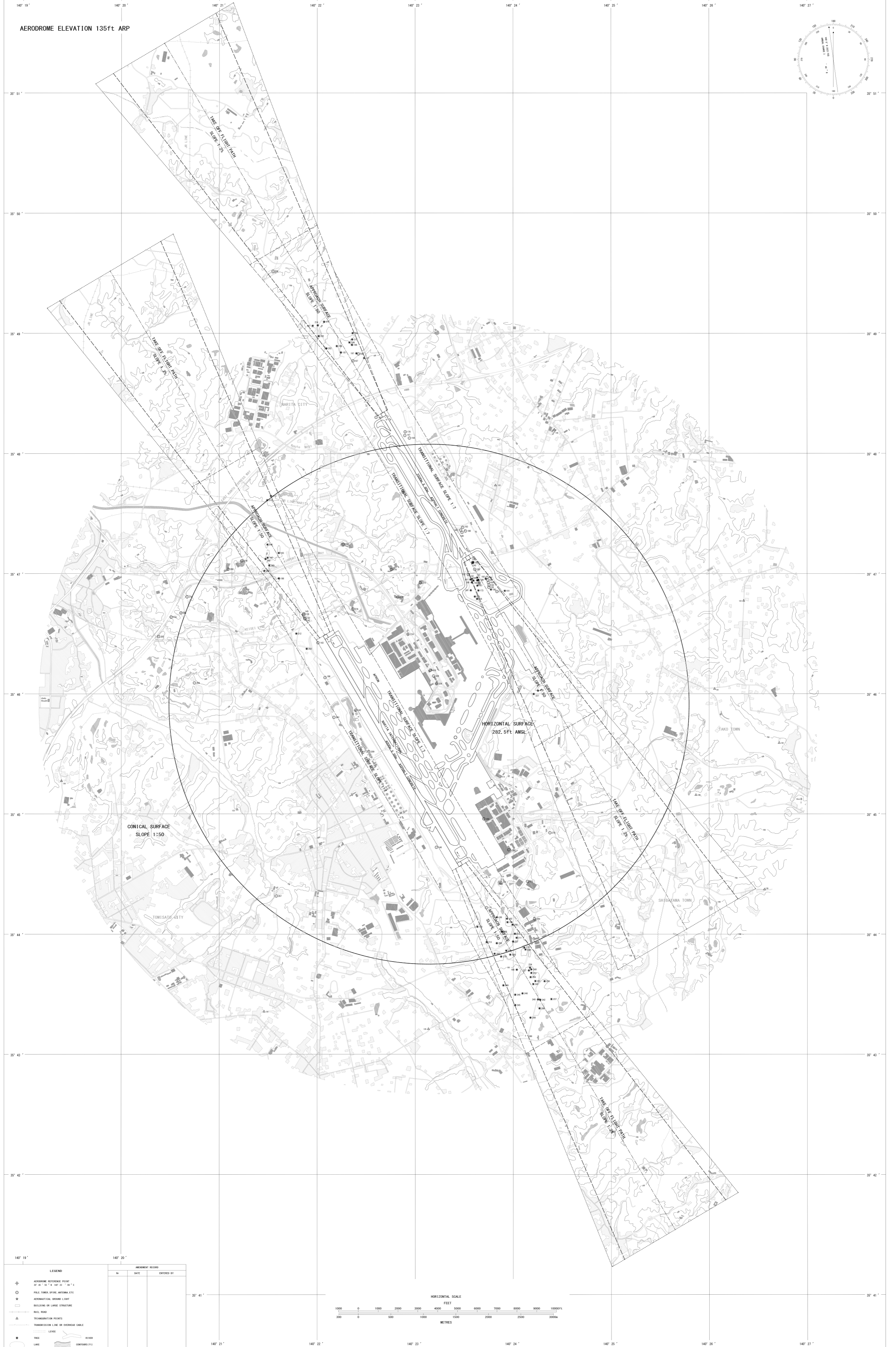

CHANGE: Update

PRECISION APPROACH TERRAIN PROFILE CHART

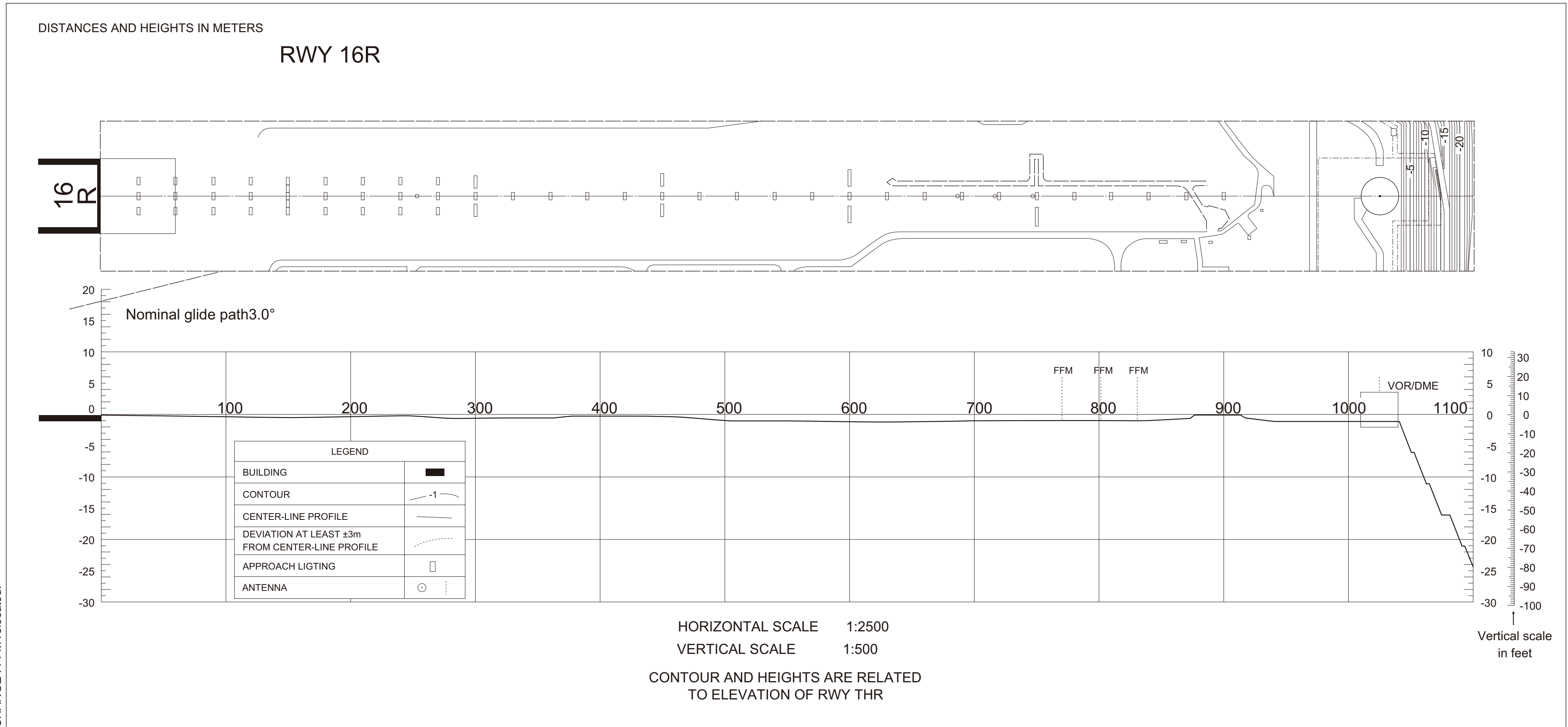

STANDARD DEPARTURE CHART -INSTRUMENT

RJAA / NARITA INTL

SID

SAKURA FIVE DEPARTURE

RWY 16R : Climb via NRE R157 to 14.0DME, turn left to intercept and proceed via NRE R129 to NRE VOR/DME, via NRE R271 to TETRA.
 Cross TETRA at or above 12000FT.

Cross TETRA at or above 12000FT.

RWY 16L : (Not established)

RWY 34L : Climb via NRE R337 to 6.0DME, turn right HDG100° until crossing NRE R036, turn right HDG160° to intercept and proceed via NRE R103 to NRE VOR/DME, via NRE R271 to TETRA.
 Cross NRE R001 at or above 3000FT,
 cross NRE R036 between 4000FT and 7000FT,
 cross TETRA at or above 12000FT.

Cross NRE R001 at or above 3000FT,
 cross NRE R036 between 4000FT and 7000FT,
 cross TETRA at or above 12000FT.

RWY 34R : (Not established)

CHANGE : PROC renamed. PROC FM RWY 16L/34R abolished. HOKUSO VOR/DME(HKE) abolished.

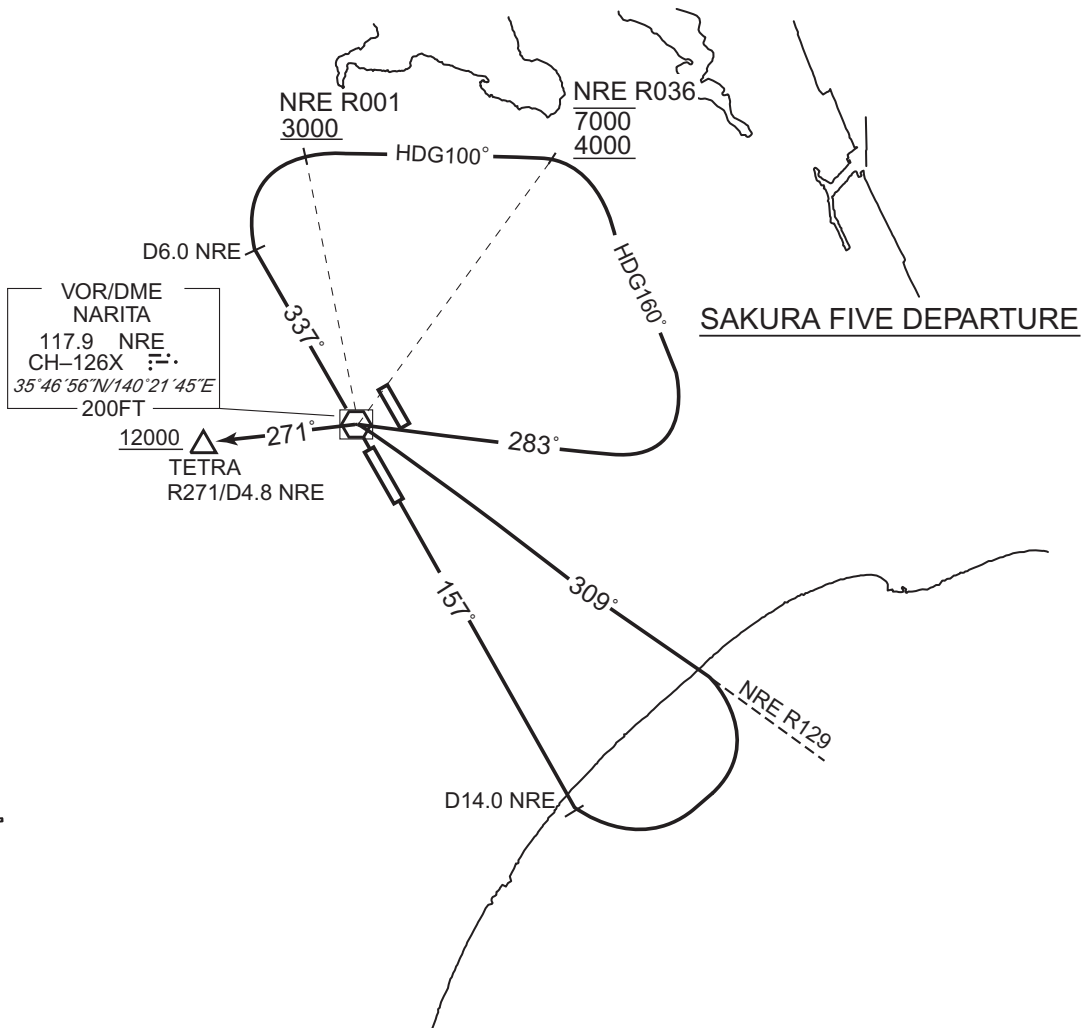

STANDARD DEPARTURE CHART -INSTRUMENT

RJAA / NARITA INTL

TRANSITION

SHIZUOKA TRANSITION

From over TETRA, via HME R070 to HME VOR/DME, via HME R247/SZE R066 to SZE VOR/DME.

Cross HME VOR/DME at or above FL200.

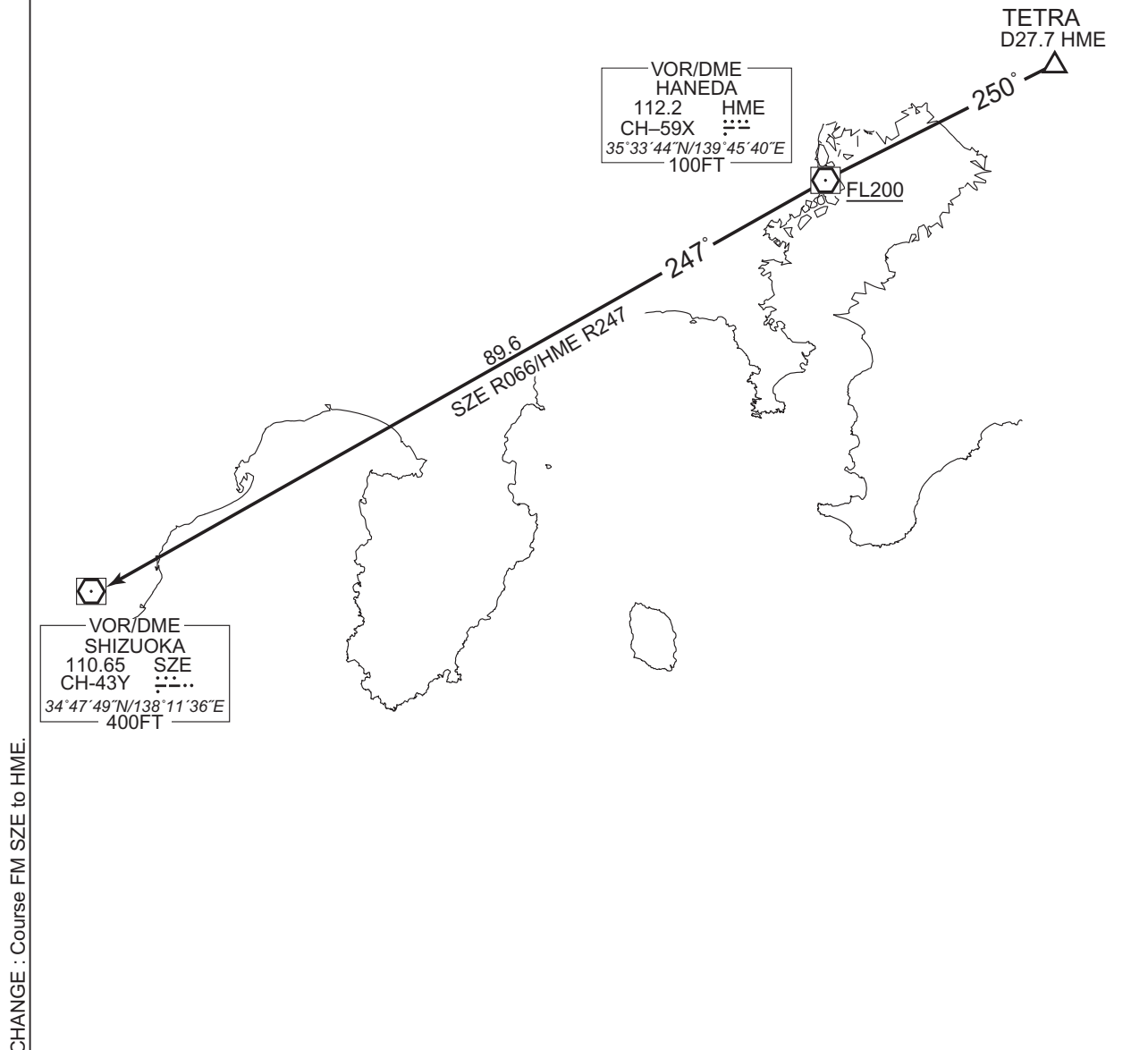

STANDARD DEPARTURE CHART -INSTRUMENT

RJAA / NARITA INTL

SID

AKAGI FOUR DEPARTURE

RWY16R : Climb via NRE R157 to 14.0DME, turn right, direct to NRE VOR/DME, via NRE R326 to AKAGI via LOPIA and YAOKO.

Cross LOPIA at or above 12000FT, cross YAOKO at or above FL180.

RWY16L : (Not established)

RWY34L : Climb via NRE R337 to 6.0DME, turn right HDG100° until crossing NRE R036, turn right HDG160° to intercept and proceed via NRE R103 to NRE VOR/DME, via NRE R326 to AKAGI via LOPIA and YAOKO.

Cross NRE R001 at or above 3000FT,
 cross NRE R036 between 4000FT and 7000FT,
 cross LOPIA at or above 12000FT, cross YAOKO at or above FL180.

RWY34R : (Not established)

CHANGE : PROC renamed. PROC FM RWY 16L/34R abolished. HOKUSO VOR/DME(HKE) abolished.

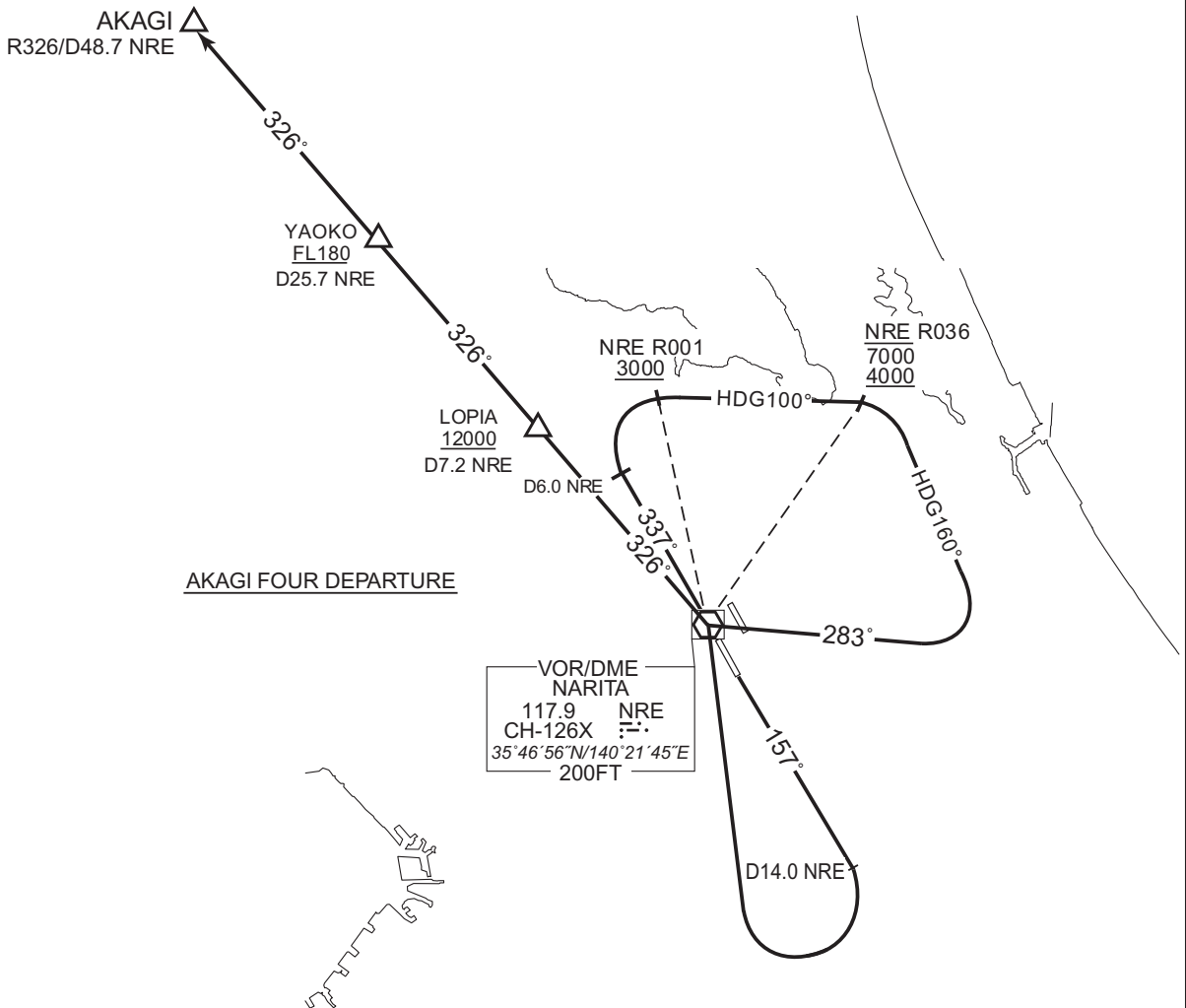

STANDARD DEPARTURE CHART -INSTRUMENT

RJAA / NARITA INTL

SID

SUNNS TWO DEPARTURE

RWY16R : Climb via NRE R157 to 14.0DME, turn left HDG108° to intercept and proceed via NRE R138 to SUNNS via ROUSY.

Cross ROUSY at or above 7000FT, cross SUNNS at or above FL190.

RWY16L : (Not established)

RWY34L : Climb via NRE R337 to 6.0DME, turn right, direct to NRE VOR/DME, via NRE R138 to SUNNS via ROUSY.

Cross NRE R001 at or above 2800FT,

cross NRE R018 at or below 7000FT,

cross ROUSY at or above 7000FT, cross SUNNS at or above FL190.

RWY34R : (Not established)

CHANGE : PROC renamed. PROC FM RWY 16L/34R abolished. HOKUSO VOR/DME(HIKE) abolished.

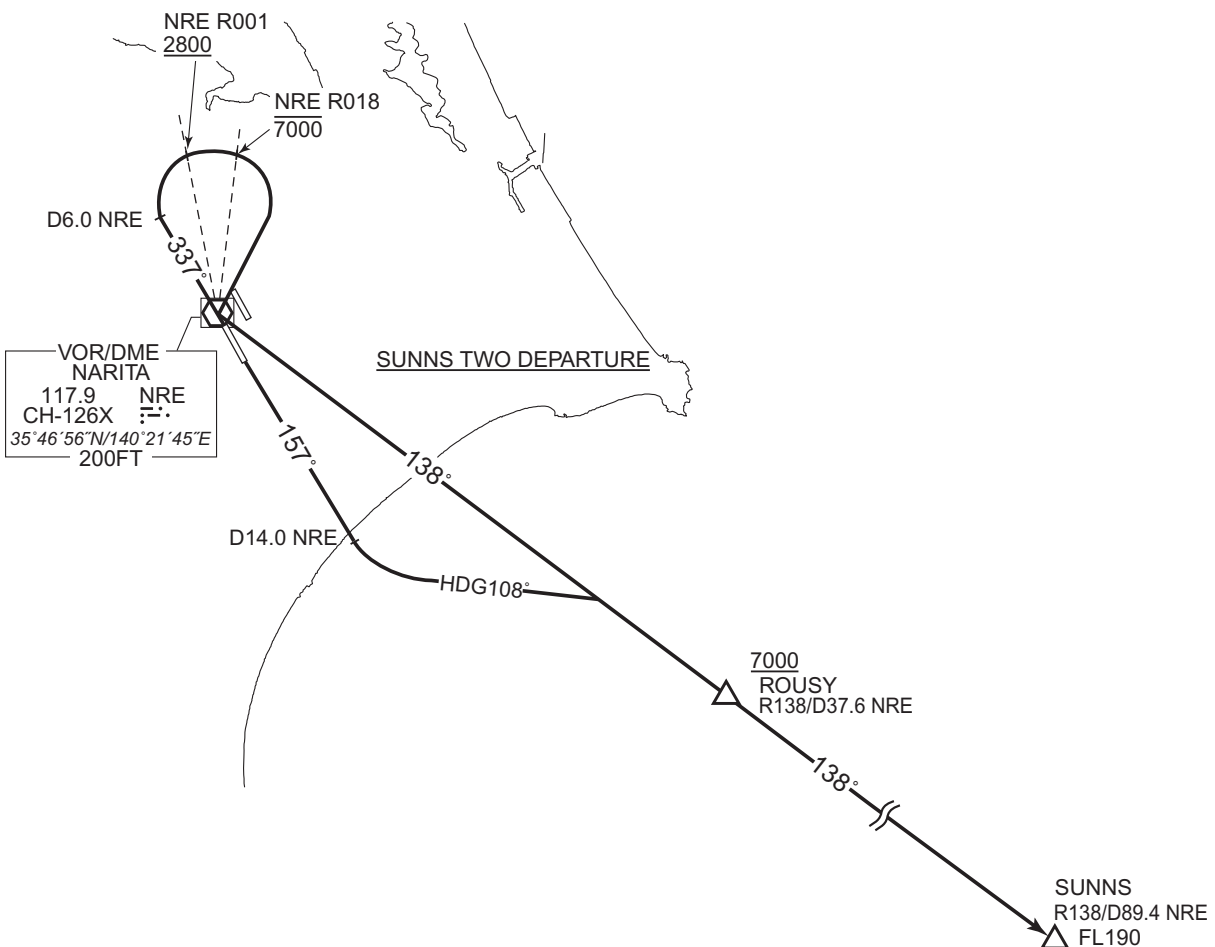

STANDARD DEPARTURE CHART -INSTRUMENT

RJAA / NARITA INTL

RNAV SID

TETRA EIGHT DEPARTURE

RNAV1

Note 1) DME/DME/IRU or GNSS required.
 ※The aircraft equipped with only DME/DME/IRU must be able to update its position without delay at the starting point of take-off rolling.
 2) RADAR service required.

Critical DME	RWY16R : TLD DER - 1.3NM FM DER RWY16L : TLD DER - 3.4NM FM DER
DME GAP	RWY34L : DER - 1.3NM FM DER
Inappropriate NavAids	See AD1.1.6.10.3. Inappropriate NAVAIDs for RNAV1

VAR 8° W

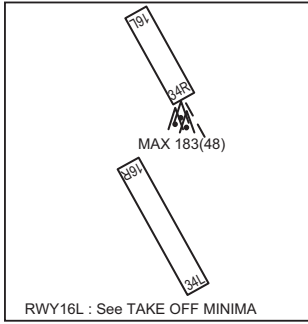

VOR/DME
NARITA
117.9 NRE
CH-126X
35°46'56"N/140°21'45"E
200FT

PHLOX
FL160

TACAN
CHOSHI
1170 CVT
CH-83X
35°43'36"N/140°48'00"E
200FT

CHANGE : Description of VAR.

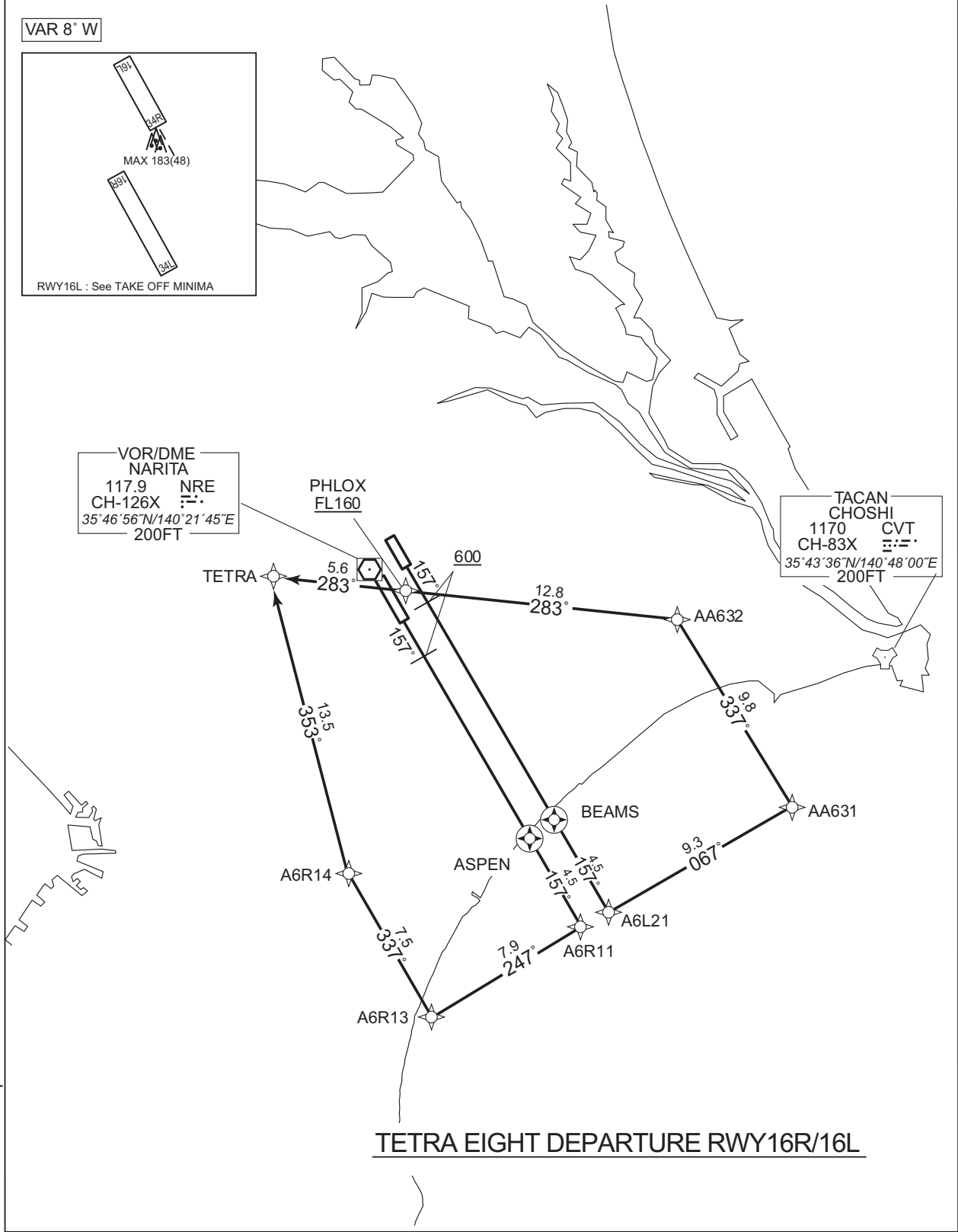

TETRA EIGHT DEPARTURE RWY16R/16L

STANDARD DEPARTURE CHART -INSTRUMENT

RJAA / NARITA INTL

RNAV SID

VAR 8° W

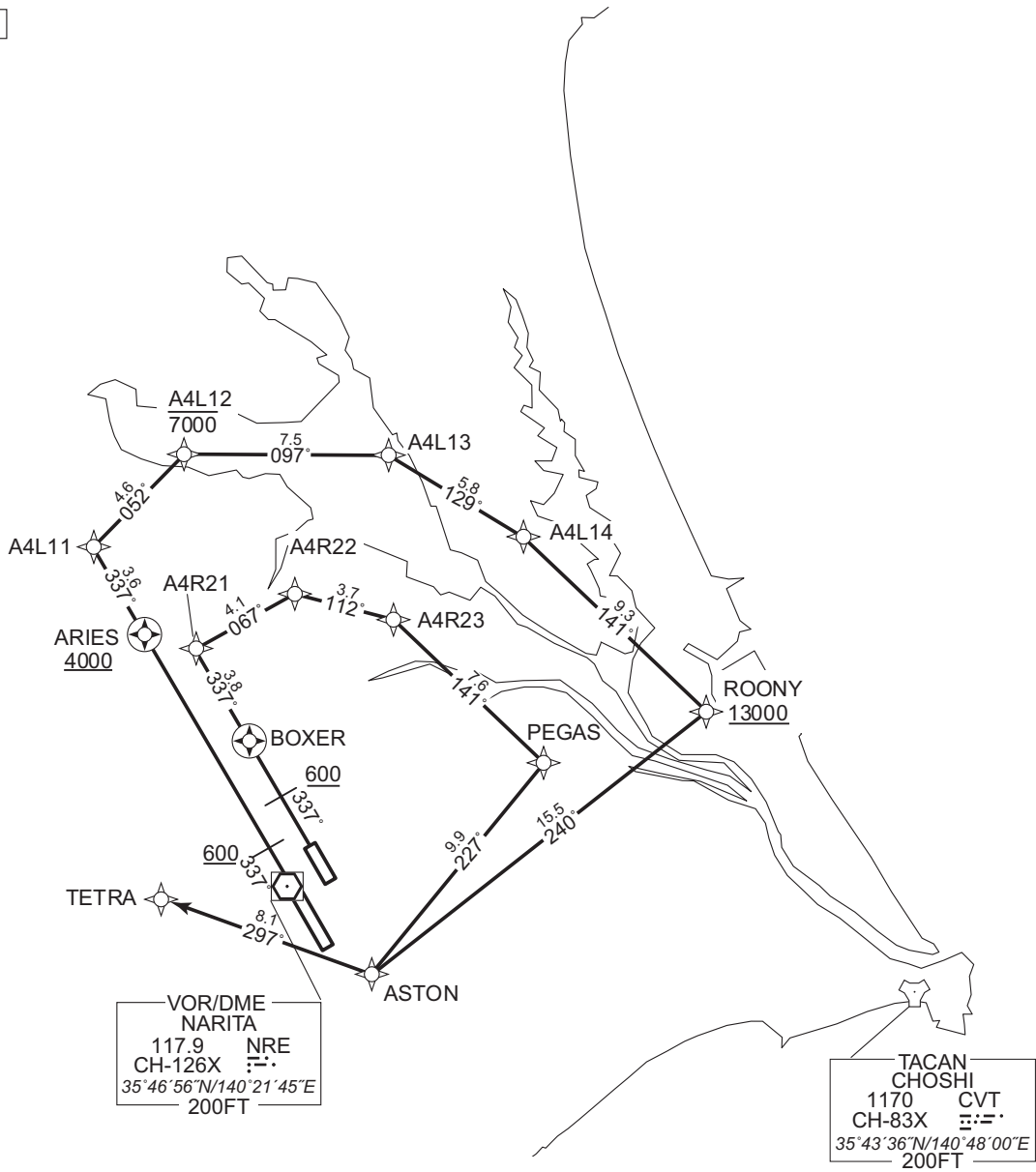

TETRA EIGHT DEPARTURE RWY34L/34R

CHANGE : Description of VAR.

STANDARD DEPARTURE CHART -INSTRUMENT

RJAA / NARITA INTL

RNAV SID

TETRA EIGHT DEPARTURE

RWY16R : Climb on HDG157° at or above 600FT, direct to ASPEN, to A6R11, to A6R13, to A6R14, to TETRA.

RWY16L : Climb on HDG157° at or above 600FT, direct to BEAMS, to A6L21, to AA631, to AA632, to PHLOX at or above FL160, to TETRA.

RWY34L : Climb on HDG337° at or above 600FT, direct to ARIES at or above 4000FT, to A4L11, to A4L12 at or below 7000FT, to A4L13, to A4L14, to ROONY at or above 13000FT, to ASTON, to TETRA.

RWY34R : Climb on HDG337° at or above 600FT, direct to BOXER, to A4R21, to A4R22, to A4R23, to PEGAS, to ASTON, to TETRA.

RWY16R *MUST be used for database coding.

Serial Number	Path Descriptor*	Waypoint Identifier	Fly Over	Course °M(^T)	Magnetic Variation	Distance (NM)	Turn Direction	Altitude (FT)	Speed (KIAS)	Vertical Angle	Navigation Specification
001	VA	-	-	157 (149.6)	-7.5	-	-	+600	-	-	RNAV1
002	DF	ASPEN	Y	-	-7.5	-	-	-	-	-	RNAV1
003	TF	A6R11	-	157 (149.7)	-7.5	4.5	-	-	-	-	RNAV1
004	TF	A6R13	-	247 (239.5)	-7.5	7.9	-	-	-	-	RNAV1
005	TF	A6R14	-	337 (329.6)	-7.5	7.5	-	-	-	-	RNAV1
006	TF	TETRA	-	353 (345.1)	-7.5	13.5	-	-	-	-	RNAV1

RWY16L *MUST be used for database coding.

Serial Number	Path Descriptor*	Waypoint Identifier	Fly Over	Course °M(^T)	Magnetic Variation	Distance (NM)	Turn Direction	Altitude (FT)	Speed (KIAS)	Vertical Angle	Navigation Specification
001	VA	-	-	157 (149.6)	-7.5	-	-	+600	-	-	RNAV1
002	DF	BEAMS	Y	-	-7.5	-	-	-	-	-	RNAV1
003	TF	A6L21	-	157 (149.7)	-7.5	4.5	-	-	-	-	RNAV1
004	TF	AA631	-	067 (059.5)	-7.5	9.3	-	-	-	-	RNAV1
005	TF	AA632	-	337 (329.8)	-7.5	9.8	-	-	-	-	RNAV1
006	TF	PHLOX	-	283 (275.3)	-7.5	12.8	-	+FL160	-	-	RNAV1
007	TF	TETRA	-	283 (275.1)	-7.5	5.6	-	-	-	-	RNAV1

CHANGE : ALT Restriction on A4R23. PROC renamed.

STANDARD DEPARTURE CHART -INSTRUMENT

RJAA / NARITA INTL

RNAV SID

RWY34L *MUST be used for database coding.

Serial Number	Path Descriptor*	Waypoint Identifier	Fly Over	Course °M(°T)	Magnetic Variation	Distance (NM)	Turn Direction	Altitude (FT)	Speed (KIAS)	Vertical Angle	Navigation Specification
001	VA	-	-	337 (329.6)	-7.5	-	-	+600	-	-	RNAV1
002	DF	ARIES	Y	-	-7.5	-	-	+4000	-	-	RNAV1
003	TF	A4L11	-	337 (329.5)	-7.5	3.6	-	-	-	-	RNAV1
004	TF	A4L12	-	052 (044.3)	-7.5	4.6	-	-7000	-	-	RNAV1
005	TF	A4L13	-	097 (089.4)	-7.5	7.5	-	-	-	-	RNAV1
006	TF	A4L14	-	129 (121.2)	-7.5	5.8	-	-	-	-	RNAV1
007	TF	ROONY	-	141 (133.2)	-7.5	9.3	-	+13000	-	-	RNAV1
008	TF	ASTON	-	240 (232.1)	-7.5	15.5	-	-	-	-	RNAV1
009	TF	TETRA	-	297 (289.5)	-7.5	8.1	-	-	-	-	RNAV1

RWY34R *MUST be used for database coding.

Serial Number	Path Descriptor*	Waypoint Identifier	Fly Over	Course °M(°T)	Magnetic Variation	Distance (NM)	Turn Direction	Altitude (FT)	Speed (KIAS)	Vertical Angle	Navigation Specification
001	VA	-	-	337 (329.6)	-7.5	-	-	+600	-	-	RNAV1
002	DF	BOXER	Y	-	-7.5	-	-	-	-	-	RNAV1
003	TF	A4R21	-	337 (329.6)	-7.5	3.8	-	-	-	-	RNAV1
004	TF	A4R22	-	067 (059.3)	-7.5	4.1	-	-	-	-	RNAV1
005	TF	A4R23	-	112 (104.6)	-7.5	3.7	-	-	-	-	RNAV1
006	TF	PEGAS	-	141 (133.4)	-7.5	7.6	-	-	-	-	RNAV1
007	TF	ASTON	-	227 (219.2)	-7.5	9.9	-	-	-	-	RNAV1
008	TF	TETRA	-	297 (289.5)	-7.5	8.1	-	-	-	-	RNAV1

CHANGE : ALT Restriction on A4R23

STANDARD DEPARTURE CHART -INSTRUMENT

RJAA / NARITA INTL

RNAV SID

Waypoint Coordinates

Waypoint Identifier	Coordinates	Waypoint Identifier	Coordinates
A4L11	355915.6N / 1401249.1E	AA631	353619.9N / 1404431.9E
A4L12	360232.6N / 1401646.8E	AA632	354446.7N / 1403828.9E
A4L13	360236.7N / 1402559.7E	ARIES	355607.4N / 1401505.9E
A4L14	355937.8N / 1403205.0E	ASPEN	353451.0N / 1403028.1E
A4R21	355529.4N / 1401729.2E	ASTON	354344.6N / 1402518.6E
A4R22	355734.5N / 1402150.1E	BEAMS	353533.0N / 1403153.1E
A4R23	355638.8N / 1402614.7E	BOXER	355213.0N / 1401951.6E
A6L21	353137.9N / 1403441.9E	PEGAS	355126.3N / 1403302.1E
A6R11	353056.9N / 1403316.2E	PHLOX	354556.6N / 1402246.1E
A6R13	352654.9N / 1402452.6E	ROONY	355317.4N / 1404024.4E
A6R14	353324.7N / 1402011.9E	TETRA	354626.4N / 1401555.8E

CHANGE : Update

STANDARD DEPARTURE CHART -INSTRUMENT

RJAA / NARITA INTL

RNAV TRANSITION

AGRIS TRANSITION /KIMIN TRANSITION / ENPAR TRANSITION		RNAV1
Note 1) DME/DME/IRU or GNSS required. 2) RADAR service required.	Critical DME	-
	DME GAP	-
	Inappropriate Nav aids	See AD1.1.6.10.3.Inappropriate NAVAIDs for RNAV1

VAR8°W

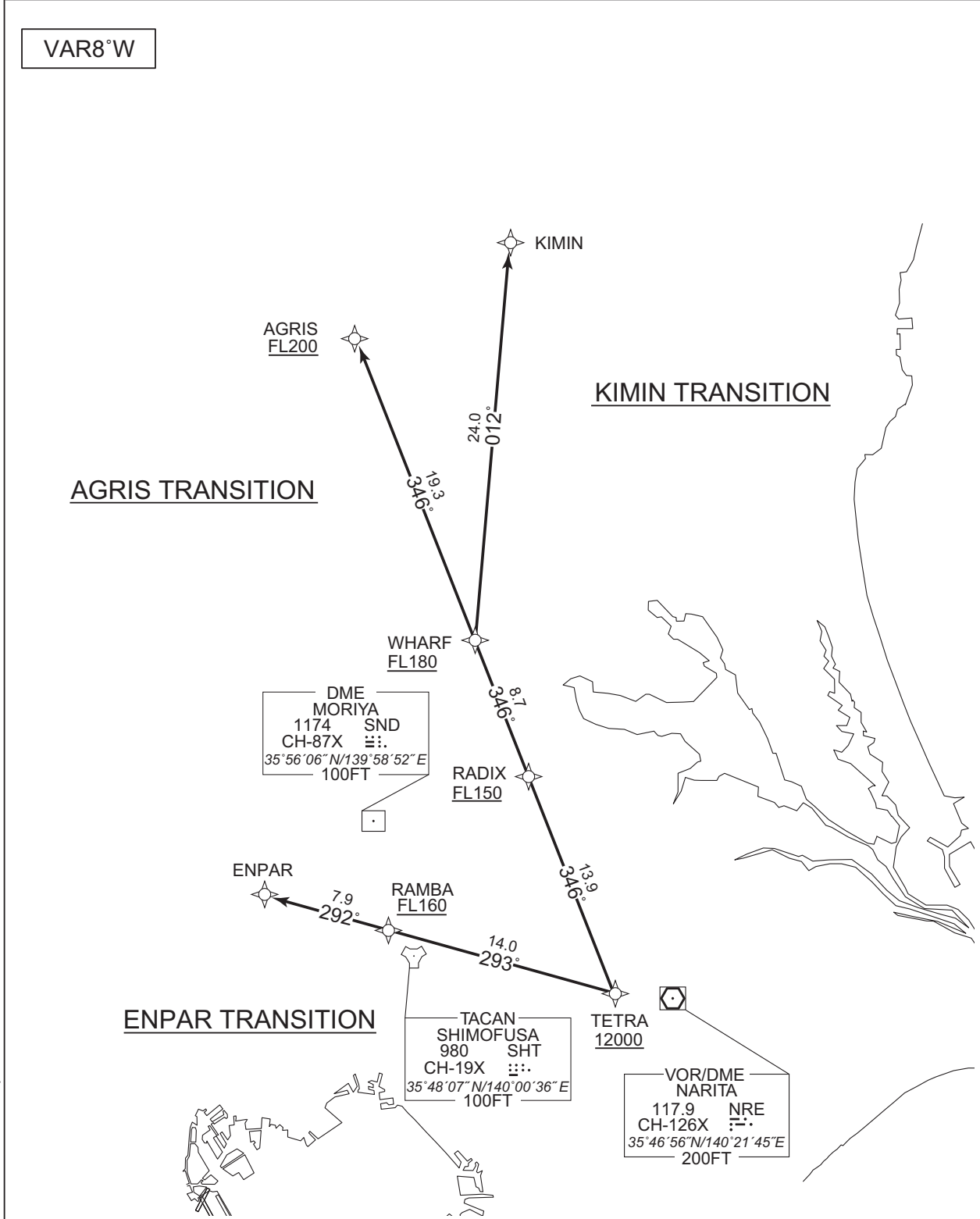

CHANGE : Description of VAR.

STANDARD DEPARTURE CHART -INSTRUMENT

RJAA / NARITA INTL

RNAV TRANSITION

AGRIS TRANSITION

From TETRA at or above 12000FT, to RADIX at or above FL150, to WHARF at or above FL180, to AGRIS at or above FL200.

Serial Number	Path Descriptor	Waypoint Identifier	Fly Over	Course °M(°T)	Magnetic Variation	Distance (NM)	Turn Direction	Altitude (FT)	Speed (KIAS)	Vertical Angle	Navigation Specification
001	IF	TETRA	-	-	-7.5	-	-	+12000	-	-	RNAV1
002	TF	RADIX	-	346 (338.1)	-7.5	13.9	-	+FL150	-	-	RNAV1
003	TF	WHARF	-	346 (338.1)	-7.5	8.7	-	+FL180	-	-	RNAV1
004	TF	AGRIS	-	346 (338.0)	-7.5	19.3	-	+FL200	-	-	RNAV1

KIMIN TRANSITION

From TETRA at or above 12000FT, to RADIX at or above FL150, to WHARF at or above FL180, to KIMIN.

Serial Number	Path Descriptor	Waypoint Identifier	Fly Over	Course °M(°T)	Magnetic Variation	Distance (NM)	Turn Direction	Altitude (FT)	Speed (KIAS)	Vertical Angle	Navigation Specification
001	IF	TETRA	-	-	-7.5	-	-	+12000	-	-	RNAV1
002	TF	RADIX	-	346 (338.1)	-7.5	13.9	-	+FL150	-	-	RNAV1
003	TF	WHARF	-	346 (338.1)	-7.5	8.7	-	+FL180	-	-	RNAV1
004	TF	KIMIN	-	012 (004.1)	-7.5	24.0	-	-	-	-	RNAV1

ENPAR TRANSITION

From TETRA at or above 12000FT, to RAMBA at or above FL160, to ENPAR.

Serial Number	Path Descriptor	Waypoint Identifier	Fly Over	Course °M(°T)	Magnetic Variation	Distance (NM)	Turn Direction	Altitude (FT)	Speed (KIAS)	Vertical Angle	Navigation Specification
001	IF	TETRA	-	-	-7.5	-	-	+12000	-	-	RNAV1
002	TF	RAMBA	-	293 (285.1)	-7.5	14.0	-	+FL160	-	-	RNAV1
003	TF	ENPAR	-	292 (284.9)	-7.5	7.9	-	-	-	-	RNAV1

Waypoint Coordinates

Waypoint Identifier	Coordinates	Waypoint Identifier	Coordinates
AGRIS	362514.7N / 1395633.1E	RAMBA	355003.7N / 1395917.7E
ENPAR	355205.2N / 1394954.3E	TETRA	354626.4N / 1401555.8E
KIMIN	363119.5N / 1400738.2E	WHARF	360722.6N / 1400531.1E
RADIX	355917.2N / 1400933.2E		

CHANGE : New PROC

STANDARD DEPARTURE CHART -INSTRUMENT

RJAA / NARITA INTL

RNAV SID

REDEK TWO DEPARTURE		RNAV1
Note 1) DME/DME/IRU or GNSS required. ※ The aircraft equipped with only DME/DME/IRU must be able to update its position without delay at the starting point of take-off rolling. 2) RADAR service required.	Critical DME	RWY16R:TLD DER – 1.3NM FM DER RWY16L :TLD DER – 3.4NM FM DER
	DME GAP	RWY34L :DER – 1.3NM FM DER
	Inappropriate NavAids	See AD1.1.6.10.3.Inappropriate NAVAIDs for RNAV1

VAR 8° W

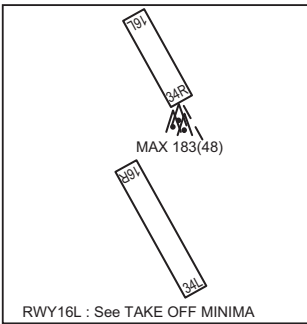

TACAN
SHIMOFUSA
980 SHT
CH-19X
35°48'07"N/140°00'36"E
100FT

VOR/DME
NARITA
117.9 NRE
CH-126X
35°46'56"N/140°21'45"E
200FT

TACAN
CHOSHI
1170 CVT
CH-83X
35°43'36"N/140°48'00"E
200FT

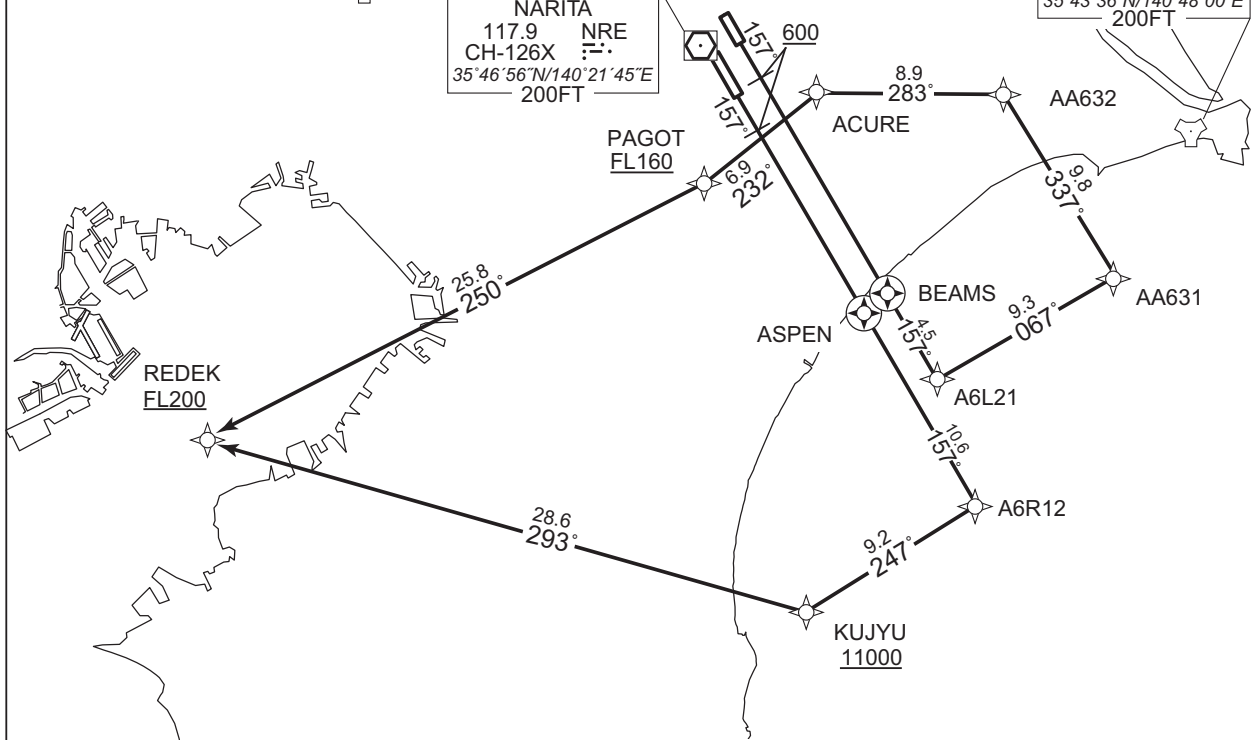

REDEK TWO DEPARTURE RWY16R/16L

TACAN
ONJUKU
1191 OJT
CH-104X
35°11'03"N/140°22'17"E
400FT

CHANGE : Description of VAR.

STANDARD DEPARTURE CHART -INSTRUMENT

RJAA / NARITA INTL

RNAV SID

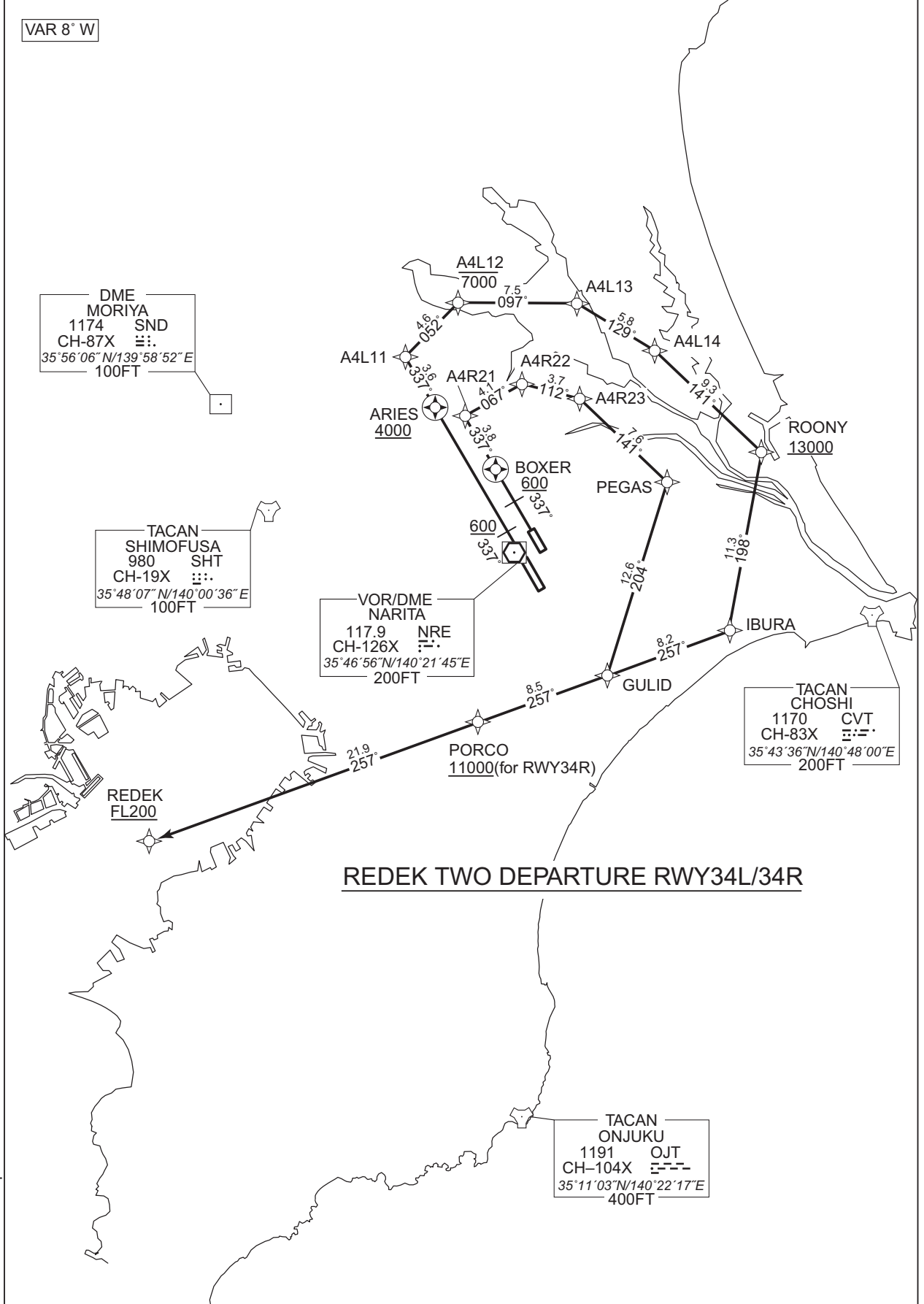

CHANGE : Description of VAR.

STANDARD DEPARTURE CHART -INSTRUMENT

RJAA / NARITA INTL

RNAV SID

REDEK TWO DEPARTURE

RWY16R : Climb on HDG 157° at or above 600FT, direct to ASPEN, to A6R12, to KUJYU at or above 11000FT, to REDEK at or above FL200.

RWY16L : Climb on HDG 157° at or above 600FT, direct to BEAMS, to A6L21, to AA631, to AA632, to ACURE, to PAGOT at or above FL160, to REDEK at or above FL200.

RWY34L : Climb on HDG 337° at or above 600FT, direct to ARIES at or above 4000FT, to A4L11, to A4L12 at or below 7000FT, to A4L13, to A4L14, to ROONY at or above 13000FT, to IBURA, to GULID, to PORCO, to REDEK at or above FL200.

RWY34R : Climb on HDG 337° at or above 600FT, direct to BOXER, to A4R21, to A4R22, to A4R23, to PEGAS, to GULID, to PORCO at or above 11000FT, to REDEK at or above FL200.

RWY16R *MUST be used for database coding.

Serial Number	Path Descriptor*	Waypoint Identifier	Fly Over	Course °M(°T)	Magnetic Variation	Distance (NM)	Turn Direction	Altitude (FT)	Speed (KIAS)	Vertical Angle	Navigation Specification
001	VA	-	-	157 (149.6)	-7.5	-	-	+600	-	-	RNAV1
002	DF	ASPEN	Y	-	-7.5	-	-	-	-	-	RNAV1
003	TF	A6R12	-	157 (149.7)	-7.5	10.6	-	-	-	-	RNAV1
004	TF	KUJYU	-	247 (239.5)	-7.5	9.2	-	+11000	-	-	RNAV1
005	TF	REDEK	-	293 (285.7)	-7.5	28.6	-	+FL200	-	-	RNAV1

RWY16L *MUST be used for database coding.

Serial Number	Path Descriptor*	Waypoint Identifier	Fly Over	Course °M(°T)	Magnetic Variation	Distance (NM)	Turn Direction	Altitude (FT)	Speed (KIAS)	Vertical Angle	Navigation Specification
001	VA	-	-	157 (149.6)	-7.5	-	-	+600	-	-	RNAV1
002	DF	BEAMS	Y	-	-7.5	-	-	-	-	-	RNAV1
003	TF	A6L21	-	157 (149.7)	-7.5	4.5	-	-	-	-	RNAV1
004	TF	AA631	-	067 (059.5)	-7.5	9.3	-	-	-	-	RNAV1
005	TF	AA632	-	337 (329.8)	-7.5	9.8	-	-	-	-	RNAV1
006	TF	ACURE	-	283 (275.3)	-7.5	8.9	-	-	-	-	RNAV1
007	TF	PAGOT	-	232 (224.1)	-7.5	6.9	-	+FL160	-	-	RNAV1
008	TF	REDEK	-	250 (242.6)	-7.5	25.8	-	+FL200	-	-	RNAV1

CHANGE : ALT Restriction on A4R23. PROC renamed.

STANDARD DEPARTURE CHART -INSTRUMENT

RJAA / NARITA INTL

RNAV SID

RWY34L

*MUST be used for database coding.

Serial Number	Path Descriptor*	Waypoint Identifier	Fly Over	Course °M(^T)	Magnetic Variation	Distance (NM)	Turn Direction	Altitude (FT)	Speed (KIAS)	Vertical Angle	Navigation Specification
001	VA	-	-	337 (329.6)	-7.5	-	-	+600	-	-	RNAV1
002	DF	ARIES	Y	-	-7.5	-	-	+4000	-	-	RNAV1
003	TF	A4L11	-	337 (329.5)	-7.5	3.6	-	-	-	-	RNAV1
004	TF	A4L12	-	052 (044.3)	-7.5	4.6	-	-7000	-	-	RNAV1
005	TF	A4L13	-	097 (089.4)	-7.5	7.5	-	-	-	-	RNAV1
006	TF	A4L14	-	129 (121.2)	-7.5	5.8	-	-	-	-	RNAV1
007	TF	ROONY	-	141 (133.2)	-7.5	9.3	-	+13000	-	-	RNAV1
008	TF	IBURA	-	198 (190.0)	-7.5	11.3	-	-	-	-	RNAV1
009	TF	GULID	-	257 (249.8)	-7.5	8.2	-	-	-	-	RNAV1
010	TF	PORCO	-	257 (249.7)	-7.5	8.5	-	-	-	-	RNAV1
011	TF	REDEK	-	257 (249.6)	-7.5	21.9	-	+FL200	-	-	RNAV1

RWY34R

*MUST be used for database coding.

Serial Number	Path Descriptor*	Waypoint Identifier	Fly Over	Course °M(^T)	Magnetic Variation	Distance (NM)	Turn Direction	Altitude (FT)	Speed (KIAS)	Vertical Angle	Navigation Specification
001	VA	-	-	337 (329.6)	-7.5	-	-	+600	-	-	RNAV1
002	DF	BOXER	Y	-	-7.5	-	-	-	-	-	RNAV1
003	TF	A4R21	-	337 (329.6)	-7.5	3.8	-	-	-	-	RNAV1
004	TF	A4R22	-	067 (059.3)	-7.5	4.1	-	-	-	-	RNAV1
005	TF	A4R23	-	112 (104.6)	-7.5	3.7	-	-	-	-	RNAV1
006	TF	PEGAS	-	141 (133.4)	-7.5	7.6	-	-	-	-	RNAV1
007	TF	GULID	-	204 (196.9)	-7.5	12.6	-	-	-	-	RNAV1
008	TF	PORCO	-	257 (249.7)	-7.5	8.5	-	+11000	-	-	RNAV1
009	TF	REDEK	-	257 (249.6)	-7.5	21.9	-	+FL200	-	-	RNAV1

CHANGE : ALT Restriction on A4R23.

STANDARD DEPARTURE CHART -INSTRUMENT

RJAA / NARITA INTL

RNAV SID

Waypoint Coordinates

Waypoint Identifier	Coordinates	Waypoint Identifier	Coordinates
A4L11	355915.6N / 1401249.1E	ARIES	355607.4N / 1401505.9E
A4L12	360232.6N / 1401646.8E	ASPEN	353451.0N / 1403028.1E
A4L13	360236.7N / 1402559.7E	BEAMS	353533.0N / 1403153.1E
A4L14	355937.8N / 1403205.0E	BOXER	355213.0N / 1401951.6E
A4R21	355529.4N / 1401729.2E	GULID	353921.3N / 1402830.3E
A4R22	355734.5N / 1402150.1E	IBURA	354212.1N / 1403759.5E
A4R23	355638.8N / 1402614.7E	KUJYU	352104.0N / 1402719.8E
A6L21	353137.9N / 1403441.9E	PAGOT	354039.6N / 1402139.4E
A6R12	352543.5N / 1403700.7E	PORCO	353624.3N / 1401843.5E
AA631	353619.9N / 1404431.9E	PEGAS	355126.3N / 1403302.1E
AA632	354446.7N / 1403828.9E	REDEK	352844.1N / 1395333.8E
ACURE	354535.6N / 1402732.3E	ROONY	355317.4N / 1404024.4E

CHANGE : New PROC

STANDARD DEPARTURE CHART -INSTRUMENT

RJAA / NARITA INTL

RNAV SID

PIGOK TWO DEPARTURE		RNAV1
Note 1) DME/DME/IRU or GNSS required. ※The aircraft equipped with only DME/DME/IRU must be able to update its position without delay at the starting point of take-off rolling. 2) RADAR service required.	Critical DME	RWY16R:TLD DER – 1.3NM FM DER RWY16L:TLD DER – 3.4NM FM DER
	DME GAP	RWY34L :DER – 1.3NM FM DER
	Inappropriate Nav aids	See AD1.1.6.10.3.Inappropriate NAVAIDs for RNAV1

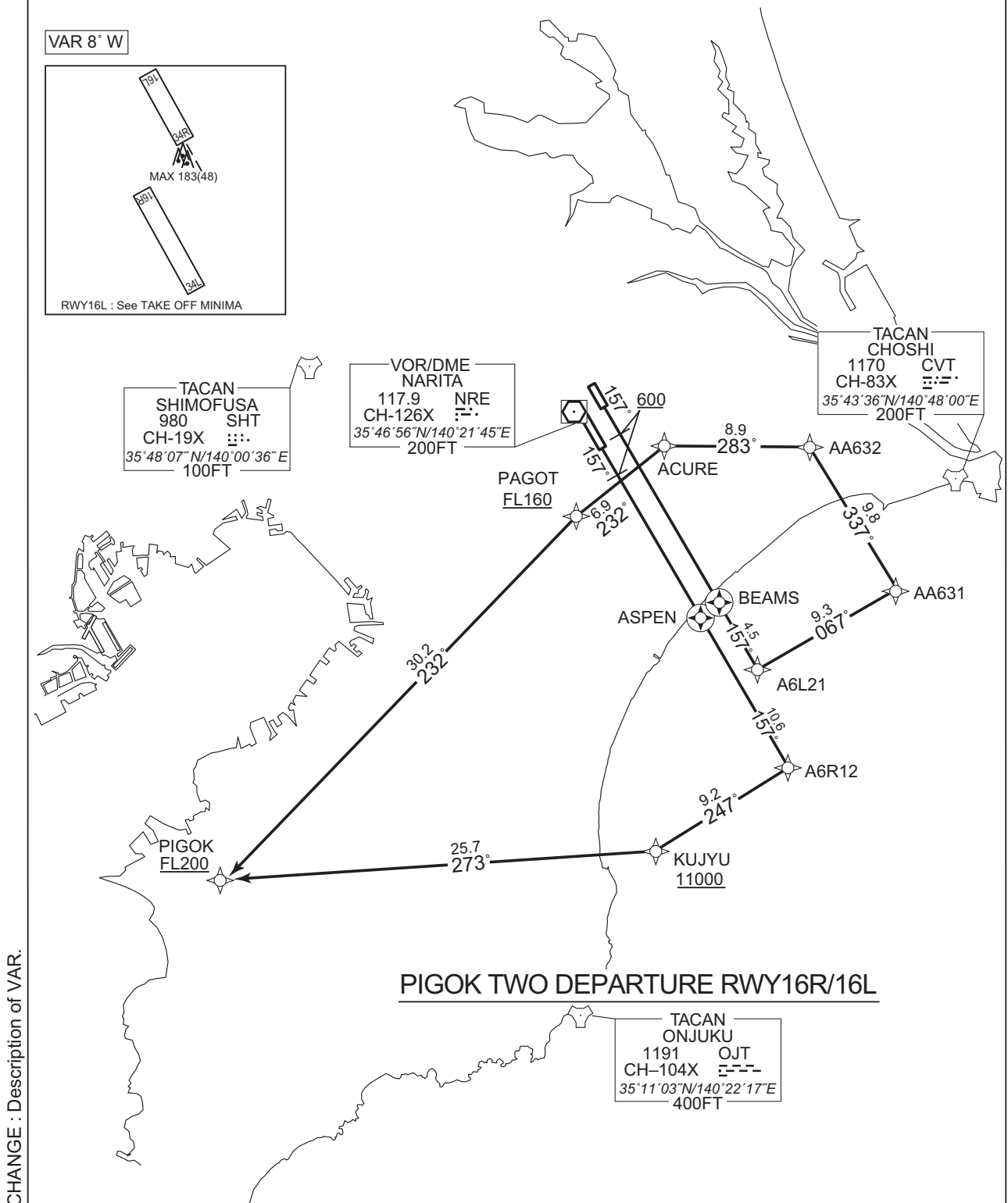
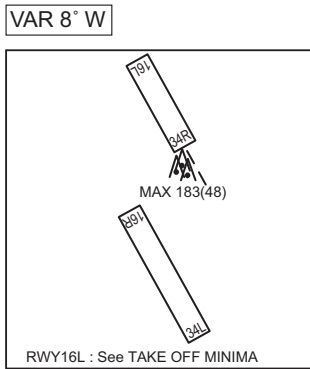

CHANGE : Description of VAR.

STANDARD DEPARTURE CHART -INSTRUMENT

RJAA / NARITA INTL

RNAV SID

VAR 8° W

DME	MORIYA
1174	SND
CH-87X	⋮⋮
35°56'06"N/139°58'52"E	
100FT	

TACAN	SHIMOFUSA
980	SHT
CH-19X	⋮⋮
35°48'07"N/140°00'36"E	
100FT	

VOR/DME	NARITA
117.9	NRE
CH-126X	⋮⋮
35°46'56"N/140°21'45"E	
200FT	

TACAN	CHOSHI
1170	CVT
CH-83X	⋮⋮
35°43'36"N/140°48'00"E	
200FT	

TACAN	ONJUKU
1191	OJT
CH-104X	⋮⋮
35°11'03"N/140°22'17"E	
400FT	

PIGOK TWO DEPARTURE RWY34L/34R

CHANGE : Description of VAR.

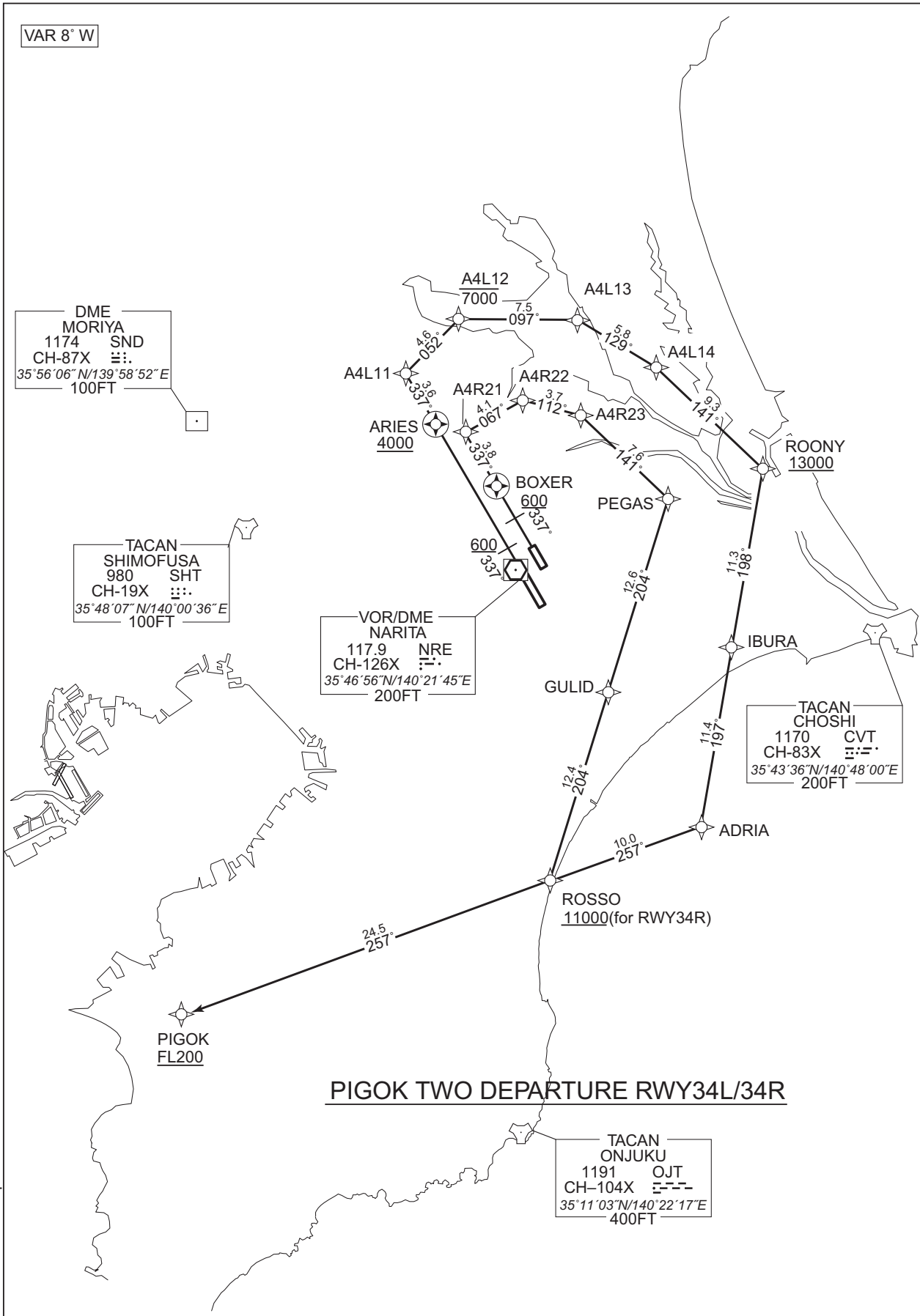

STANDARD DEPARTURE CHART -INSTRUMENT

RJAA / NARITA INTL

RNAV SID

PIGOK TWO DEPARTURE

RWY16R : Climb on HDG 157° at or above 600FT, direct to ASPEN, to A6R12, to KUJYU at or above 11000FT, to PIGOK at or above FL200.

RWY16L : Climb on HDG 157° at or above 600FT, direct to BEAMS, to A6L21, to AA631, to AA632, to ACURE, to PAGOT at or above FL160, to PIGOK at or above FL200.

RWY34L : Climb on HDG 337° at or above 600FT, direct to ARIES at or above 4000FT, to A4L11, to A4L12 at or below 7000FT, to A4L13, to A4L14, to ROONY at or above 13000FT, to IBURA, to ADRIA, to ROSSO, to PIGOK at or above FL200.

RWY34R : Climb on HDG 337° at or above 600FT, direct to BOXER, to A4R21, to A4R22, to A4R23, to PEGAS, to GULID, to ROSSO at or above 11000FT, to PIGOK at or above FL200.

RWY16R *MUST be used for database coding.

Serial Number	Path Descriptor*	Waypoint Identifier	Fly Over	Course °M(°T)	Magnetic Variation	Distance (NM)	Turn Direction	Altitude (FT)	Speed (KIAS)	Vertical Angle	Navigation Specification
001	VA	-	-	157 (149.6)	-7.5	-	-	+600	-	-	RNAV1
002	DF	ASPEN	Y	-	-7.5	-	-	-	-	-	RNAV1
003	TF	A6R12	-	157 (149.7)	-7.5	10.6	-	-	-	-	RNAV1
004	TF	KUJYU	-	247 (239.5)	-7.5	9.2	-	+11000	-	-	RNAV1
005	TF	PIGOK	-	273 (265.3)	-7.5	25.7	-	+FL200	-	-	RNAV1

RWY16L *MUST be used for database coding.

Serial Number	Path Descriptor*	Waypoint Identifier	Fly Over	Course °M(°T)	Magnetic Variation	Distance (NM)	Turn Direction	Altitude (FT)	Speed (KIAS)	Vertical Angle	Navigation Specification
001	VA	-	-	157 (149.6)	-7.5	-	-	+600	-	-	RNAV1
002	DF	BEAMS	Y	-	-7.5	-	-	-	-	-	RNAV1
003	TF	A6L21	-	157 (149.7)	-7.5	4.5	-	-	-	-	RNAV1
004	TF	AA631	-	067 (059.5)	-7.5	9.3	-	-	-	-	RNAV1
005	TF	AA632	-	337 (329.8)	-7.5	9.8	-	-	-	-	RNAV1
006	TF	ACURE	-	283 (275.3)	-7.5	8.9	-	-	-	-	RNAV1
007	TF	PAGOT	-	232 (224.1)	-7.5	6.9	-	+FL160	-	-	RNAV1
008	TF	PIGOK	-	232 (224.0)	-7.5	30.2	-	+FL200	-	-	RNAV1

CHANGE : ALT Restriction on A4R23. PROC renamed.

STANDARD DEPARTURE CHART -INSTRUMENT

RJAA / NARITA INTL

RNAV SID

RWY34L *MUST be used for database coding.

Serial Number	Path Descriptor*	Waypoint Identifier	Fly Over	Course °M(°T)	Magnetic Variation	Distance (NM)	Turn Direction	Altitude (FT)	Speed (KIAS)	Vertical Angle	Navigation Specification
001	VA	-	-	337 (329.6)	-7.5	-	-	+600	-	-	RNAV1
002	DF	ARIES	Y	-	-7.5	-	-	+4000	-	-	RNAV1
003	TF	A4L11	-	337 (329.5)	-7.5	3.6	-	-	-	-	RNAV1
004	TF	A4L12	-	052 (044.3)	-7.5	4.6	-	-7000	-	-	RNAV1
005	TF	A4L13	-	097 (089.4)	-7.5	7.5	-	-	-	-	RNAV1
006	TF	A4L14	-	129 (121.2)	-7.5	5.8	-	-	-	-	RNAV1
007	TF	ROONY	-	141 (133.2)	-7.5	9.3	-	+13000	-	-	RNAV1
008	TF	IBURA	-	198 (190.0)	-7.5	11.3	-	-	-	-	RNAV1
009	TF	ADRIA	-	197 (189.9)	-7.5	11.4	-	-	-	-	RNAV1
010	TF	ROSSO	-	257 (249.8)	-7.5	10.0	-	-	-	-	RNAV1
011	TF	PIGOK	-	257 (249.6)	-7.5	24.5	-	+FL200	-	-	RNAV1

RWY34R *MUST be used for database coding.

Serial Number	Path Descriptor*	Waypoint Identifier	Fly Over	Course °M(°T)	Magnetic Variation	Distance (NM)	Turn Direction	Altitude (FT)	Speed (KIAS)	Vertical Angle	Navigation Specification
001	VA	-	-	337 (329.6)	-7.5	-	-	+600	-	-	RNAV1
002	DF	BOXER	Y	-	-7.5	-	-	-	-	-	RNAV1
003	TF	A4R21	-	337 (329.6)	-7.5	3.8	-	-	-	-	RNAV1
004	TF	A4R22	-	067 (059.3)	-7.5	4.1	-	-	-	-	RNAV1
005	TF	A4R23	-	112 (104.6)	-7.5	3.7	-	-	-	-	RNAV1
006	TF	PEGAS	-	141 (133.4)	-7.5	7.6	-	-	-	-	RNAV1
007	TF	GULID	-	204 (196.9)	-7.5	12.6	-	-	-	-	RNAV1
008	TF	ROSSO	-	204 (196.9)	-7.5	12.4	-	+11000	-	-	RNAV1
009	TF	PIGOK	-	257 (249.6)	-7.5	24.5	-	+FL200	-	-	RNAV1

CHANGE : ALT Restriction on A4R23.

STANDARD DEPARTURE CHART -INSTRUMENT

RJAA / NARITA INTL

RNAV SID

Waypoint Coordinates

Waypoint Identifier	Coordinates	Waypoint Identifier	Coordinates
A4L11	355915.6N / 1401249.1E	ARIES	355607.4N / 1401505.9E
A4L12	360232.6N / 1401646.8E	ASPEN	353451.0N / 1403028.1E
A4L13	360236.7N / 1402559.7E	BEAMS	353533.0N / 1403153.1E
A4L14	355937.8N / 1403205.0E	BOXER	355213.0N / 1401951.6E
A4R21	355529.4N / 1401729.2E	GULID	353921.3N / 1402830.3E
A4R22	355734.5N / 1402150.1E	IBURA	354212.1N / 1403759.5E
A4R23	355638.8N / 1402614.7E	KUJYU	352104.0N / 1402719.8E
A6L21	353137.9N / 1403441.9E	PAGOT	354039.6N / 1402139.4E
A6R12	352543.5N / 1403700.7E	PEGAS	355126.3N / 1403302.1E
AA631	353619.9N / 1404431.9E	PIGOK	351854.3N / 1395555.6E
AA632	354446.7N / 1403828.9E	ROONY	355317.4N / 1404024.4E
ACURE	354535.6N / 1402732.3E	ROSSO	352729.0N / 1402404.4E
ADRIA	353056.8N / 1403534.3E		

CHANGE : New PROC

STANDARD DEPARTURE CHART -INSTRUMENT

RJAA / NARITA INTL

RNAV SID

GULBO TWO DEPARTURE		RNAV1
Note 1) DME/DME/IRU or GNSS required. ※The aircraft equipped with only DME/DME/IRU must be able to update its position without delay at the starting point of take-off rolling. 2) RADAR service required.	Critical DME	RWY16R:TLD DER – 1.3NM FM DER RWY16L:TLD DER – 3.4NM FM DER
	DME GAP	RWY34L :DER – 1.3NM FM DER
	Inappropriate Navaids	See AD1.1.6.10.3.Inappropriate NAVAIDs for RNAV1

VAR 8° W

GULBO TWO DEPARTURE

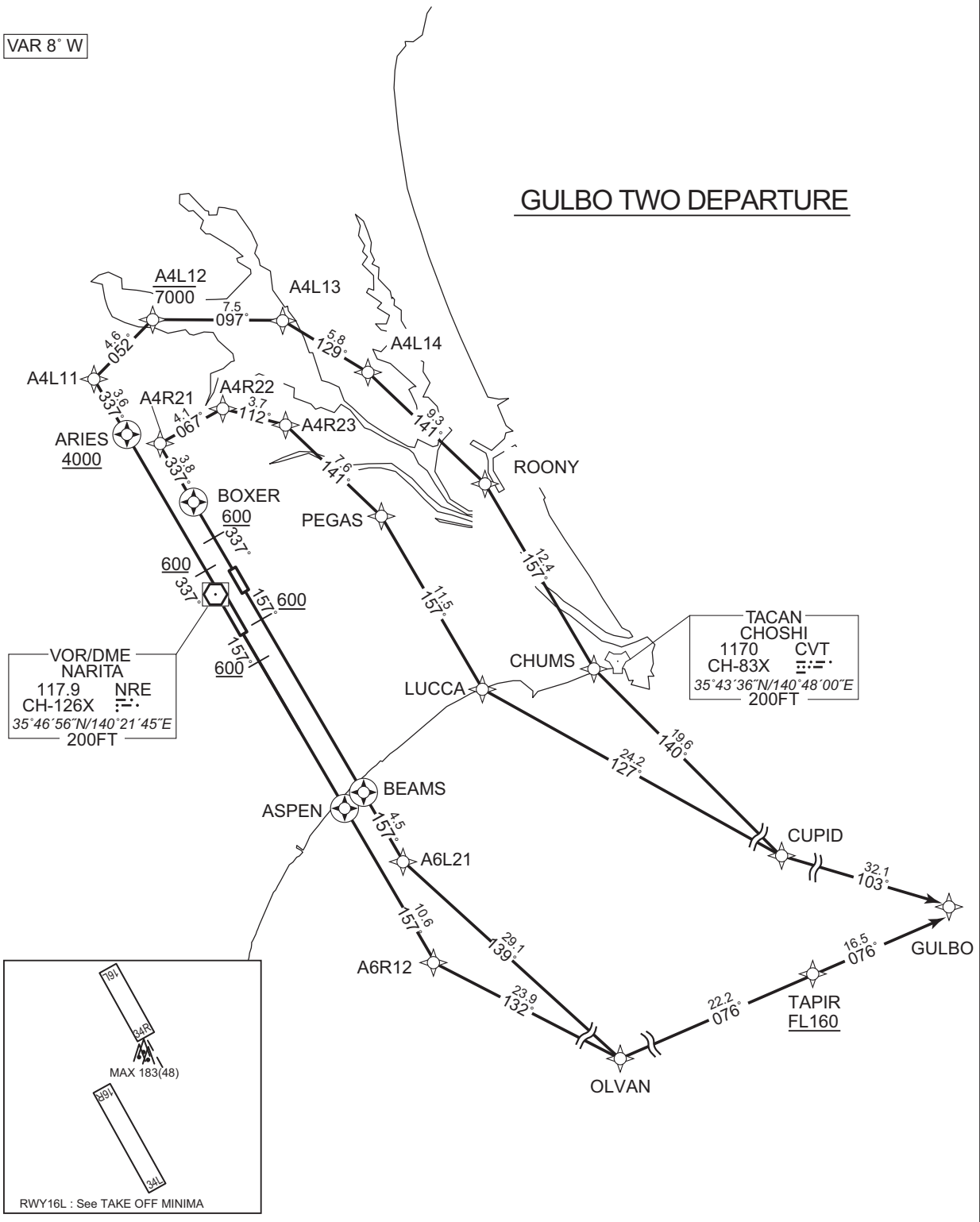

CHANGE : Description of VAR.

STANDARD DEPARTURE CHART -INSTRUMENT

RJAA / NARITA INTL

RNAV SID

GULBO TWO DEPARTURE

RWY16R : Climb on HDG 157° at or above 600FT, direct to ASPEN, to A6R12, to OLVAN, to TAPIR at or above FL160, to GULBO.

RWY16L : Climb on HDG 157° at or above 600FT, direct to BEAMS, to A6L21, to OLVAN, to TAPIR at or above FL160, to GULBO.

RWY34L : Climb on HDG 337° at or above 600FT, direct to ARIES at or above 4000FT, to A4L11, to A4L12 at or below 7000FT, to A4L13, to A4L14, to ROONY, to CHUMS, to CUPID, to GULBO.

RWY34R : Climb on HDG 337° at or above 600FT, direct to BOXER, to A4R21, to A4R22, to A4R23, to PEGAS, to LUCCA, to CUPID, to GULBO.

RWY16R *MUST be used for database coding.

Serial Number	Path Descriptor*	Waypoint Identifier	Fly Over	Course °M(^T)	Magnetic Variation	Distance (NM)	Turn Direction	Altitude (FT)	Speed (KIAS)	Vertical Angle	Navigation Specification
001	VA	-	-	157 (149.6)	-7.5	-	-	+600	-	-	RNAV1
002	DF	ASPEN	Y	-	-7.5	-	-	-	-	-	RNAV1
003	TF	A6R12	-	157 (149.7)	-7.5	10.6	-	-	-	-	RNAV1
004	TF	OLVAN	-	132 (124.2)	-7.5	23.9	-	-	-	-	RNAV1
005	TF	TAPIR	-	076 (068.0)	-7.5	22.2	-	+FL160	-	-	RNAV1
006	TF	GULBO	-	076 (068.3)	-7.5	16.5	-	-	-	-	RNAV1

RWY16L *MUST be used for database coding.

Serial Number	Path Descriptor*	Waypoint Identifier	Fly Over	Course °M(^T)	Magnetic Variation	Distance (NM)	Turn Direction	Altitude (FT)	Speed (KIAS)	Vertical Angle	Navigation Specification
001	VA	-	-	157 (149.6)	-7.5	-	-	+600	-	-	RNAV1
002	DF	BEAMS	Y	-	-7.5	-	-	-	-	-	RNAV1
003	TF	A6L21	-	157 (149.7)	-7.5	4.5	-	-	-	-	RNAV1
004	TF	OLVAN	-	139 (131.8)	-7.5	29.1	-	-	-	-	RNAV1
005	TF	TAPIR	-	076 (068.0)	-7.5	22.2	-	+FL160	-	-	RNAV1
006	TF	GULBO	-	076 (068.3)	-7.5	16.5	-	-	-	-	RNAV1

CHANGE : ALT Restriction on A4R23. PROC renamed.

STANDARD DEPARTURE CHART -INSTRUMENT

RJAA / NARITA INTL

RNAV SID

RWY34L *MUST be used for database coding.

Serial Number	Path Descriptor*	Waypoint Identifier	Fly Over	Course °M(°T)	Magnetic Variation	Distance (NM)	Turn Direction	Altitude (FT)	Speed (KIAS)	Vertical Angle	Navigation Specification
001	VA	-	-	337 (329.6)	-7.5	-	-	+600	-	-	RNAV1
002	DF	ARIES	Y	-	-7.5	-	-	+4000	-	-	RNAV1
003	TF	A4L11	-	337 (329.5)	-7.5	3.6	-	-	-	-	RNAV1
004	TF	A4L12	-	052 (044.3)	-7.5	4.6	-	-7000	-	-	RNAV1
005	TF	A4L13	-	097 (089.4)	-7.5	7.5	-	-	-	-	RNAV1
006	TF	A4L14	-	129 (121.2)	-7.5	5.8	-	-	-	-	RNAV1
007	TF	ROONY	-	141 (133.2)	-7.5	9.3	-	-	-	-	RNAV1
008	TF	CHUMS	-	157 (149.7)	-7.5	12.4	-	-	-	-	RNAV1
009	TF	CUPID	-	140 (132.0)	-7.5	19.6	-	-	-	-	RNAV1
010	TF	GULBO	-	103 (095.1)	-7.5	32.1	-	-	-	-	RNAV1

RWY34R *MUST be used for database coding.

Serial Number	Path Descriptor*	Waypoint Identifier	Fly Over	Course °M(°T)	Magnetic Variation	Distance (NM)	Turn Direction	Altitude (FT)	Speed (KIAS)	Vertical Angle	Navigation Specification
001	VA	-	-	337 (329.6)	-7.5	-	-	+600	-	-	RNAV1
002	DF	BOXER	Y	-	-7.5	-	-	-	-	-	RNAV1
003	TF	A4R21	-	337 (329.6)	-7.5	3.8	-	-	-	-	RNAV1
004	TF	A4R22	-	067 (059.3)	-7.5	4.1	-	-	-	-	RNAV1
005	TF	A4R23	-	112 (104.6)	-7.5	3.7	-	-	-	-	RNAV1
006	TF	PEGAS	-	141 (133.4)	-7.5	7.6	-	-	-	-	RNAV1
007	TF	LUCCA	-	157 (149.6)	-7.5	11.5	-	-	-	-	RNAV1
008	TF	CUPID	-	127 (119.8)	-7.5	24.2	-	-	-	-	RNAV1
009	TF	GULBO	-	103 (095.1)	-7.5	32.1	-	-	-	-	RNAV1

CHANGE : ALT Restriction on A4R23.

STANDARD DEPARTURE CHART -INSTRUMENT

RJAA / NARITA INTL

RNAV SID

Waypoint Coordinates

Waypoint Identifier	Coordinates	Waypoint Identifier	Coordinates
A4L11	355915.6N / 1401249.1E	BEAMS	353533.0N / 1403153.1E
A4L12	360232.6N / 1401646.8E	BOXER	355213.0N / 1401951.6E
A4L13	360236.7N / 1402559.7E	CHUMS	354237.0N / 1404806.0E
A4L14	355937.8N / 1403205.0E	CUPID	352930.3N / 1410557.3E
A4R21	355529.4N / 1401729.2E	GULBO	352632.9N / 1414509.6E
A4R22	355734.5N / 1402150.1E	LUCCA	354132.8N / 1404011.4E
A4R23	355638.8N / 1402614.7E	OLVAN	351214.1N / 1410111.3E
A6L21	353137.9N / 1403441.9E	PEGAS	355126.3N / 1403302.1E
A6R12	352543.5N / 1403700.7E	ROONY	355317.4N / 1404024.4E
ARIES	355607.4N / 1401505.9E	TAPIR	352028.5N / 1412621.9E
ASPEN	353451.0N / 1403028.1E		

CHANGE : New PROC

STANDARD DEPARTURE CHART -INSTRUMENT

RJAA / NARITA INTL

RNAV SID

BORLO TWO DEPARTURE		RNAV1
Note 1) DME/DME/IRU or GNSS required. ※The aircraft equipped with only DME/DME/IRU must be able to update its position without delay at the starting point of take-off rolling. 2) RADAR service required.	Critical DME	RWY16R:TLD DER – 1.3NM FM DER RWY16L:TLD DER – 3.4NM FM DER
	DME GAP	RWY34L :DER – 1.3NM FM DER
	Inappropriate Navaids	See AD1.1.6.10.3.Inappropriate NAVAIDs for RNAV1

VAR 8° W

BORLO TWO DEPARTURE

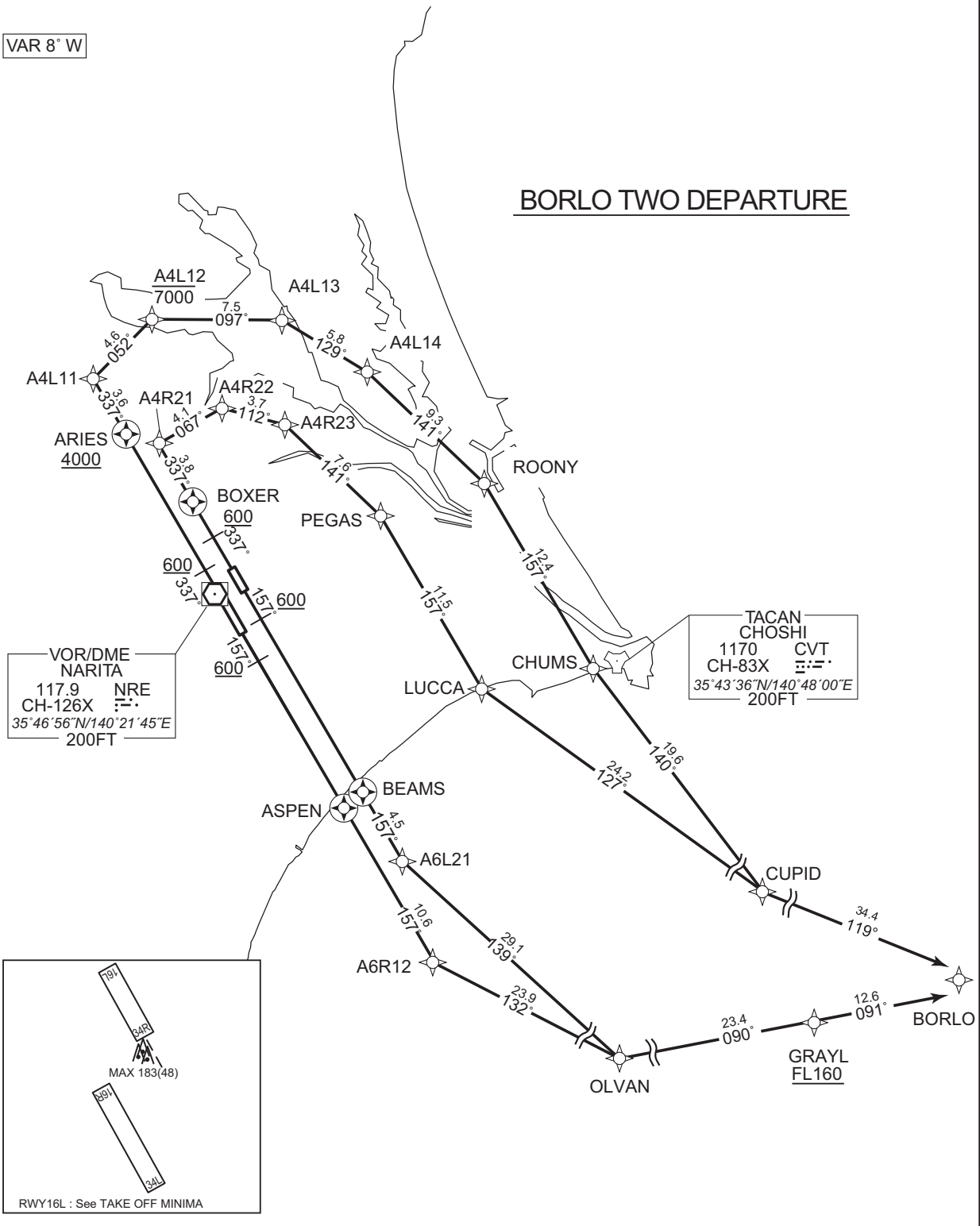

CHANGE : Description of VAR.

STANDARD DEPARTURE CHART -INSTRUMENT

RJAA / NARITA INTL

RNAV SID

BORLO TWO DEPARTURE

RWY16R : Climb on HDG 157° at or above 600FT, direct to ASPEN, to A6R12, to OLVAN, to GRAYL at or above FL160, to BORLO.

RWY16L : Climb on HDG 157° at or above 600FT, direct to BEAMS, to A6L21, to OLVAN, to GRAYL at or above FL160, to BORLO.

RWY34L : Climb on HDG 337° at or above 600FT, direct to ARIES at or above 4000FT, to A4L11, to A4L12 at or below 7000FT, to A4L13, to A4L14, to ROONY, to CHUMS, to CUPID, to BORLO.

RWY34R : Climb on HDG 337° at or above 600FT, direct to BOXER, to A4R21, to A4R22, to A4R23, to PEGAS, to LUCCA, to CUPID, to BORLO.

RWY16R *MUST be used for database coding.

Serial Number	Path Descriptor*	Waypoint Identifier	Fly Over	Course °M(^T)	Magnetic Variation	Distance (NM)	Turn Direction	Altitude (FT)	Speed (KIAS)	Vertical Angle	Navigation Specification
001	VA	-	-	157 (149.6)	-7.5	-	-	+600	-	-	RNAV1
002	DF	ASPEN	Y	-	-7.5	-	-	-	-	-	RNAV1
003	TF	A6R12	-	157 (149.7)	-7.5	10.6	-	-	-	-	RNAV1
004	TF	OLVAN	-	132 (124.2)	-7.5	23.9	-	-	-	-	RNAV1
005	TF	GRAYL	-	090 (082.9)	-7.5	23.4	-	+FL160	-	-	RNAV1
006	TF	BORLO	-	091 (083.2)	-7.5	12.6	-	-	-	-	RNAV1

RWY16L *MUST be used for database coding.

Serial Number	Path Descriptor*	Waypoint Identifier	Fly Over	Course °M(^T)	Magnetic Variation	Distance (NM)	Turn Direction	Altitude (FT)	Speed (KIAS)	Vertical Angle	Navigation Specification
001	VA	-	-	157 (149.6)	-7.5	-	-	+600	-	-	RNAV1
002	DF	BEAMS	Y	-	-7.5	-	-	-	-	-	RNAV1
003	TF	A6L21	-	157 (149.7)	-7.5	4.5	-	-	-	-	RNAV1
004	TF	OLVAN	-	139 (131.8)	-7.5	29.1	-	-	-	-	RNAV1
005	TF	GRAYL	-	090 (082.9)	-7.5	23.4	-	+FL160	-	-	RNAV1
006	TF	BORLO	-	091 (083.2)	-7.5	12.6	-	-	-	-	RNAV1

CHANGE : ALT Restriction on A4R23. PROC renamed.

STANDARD DEPARTURE CHART -INSTRUMENT

RJAA / NARITA INTL

RNAV SID

RWY34L *MUST be used for database coding.

Serial Number	Path Descriptor*	Waypoint Identifier	Fly Over	Course °M(^T)	Magnetic Variation	Distance (NM)	Turn Direction	Altitude (FT)	Speed (KIAS)	Vertical Angle	Navigation Specification
001	VA	—	—	337 (329.6)	-7.5	—	—	+600	—	—	RNAV1
002	DF	ARIES	Y	—	-7.5	—	—	+4000	—	—	RNAV1
003	TF	A4L11	—	337 (329.5)	-7.5	3.6	—	—	—	—	RNAV1
004	TF	A4L12	—	052 (044.3)	-7.5	4.6	—	-7000	—	—	RNAV1
005	TF	A4L13	—	097 (089.4)	-7.5	7.5	—	—	—	—	RNAV1
006	TF	A4L14	—	129 (121.2)	-7.5	5.8	—	—	—	—	RNAV1
007	TF	ROONY	—	141 (133.2)	-7.5	9.3	—	—	—	—	RNAV1
008	TF	CHUMS	—	157 (149.7)	-7.5	12.4	—	—	—	—	RNAV1
009	TF	CUPID	—	140 (132.0)	-7.5	19.6	—	—	—	—	RNAV1
010	TF	BORLO	—	119 (111.9)	-7.5	34.4	—	—	—	—	RNAV1

RWY34R *MUST be used for database coding.

Serial Number	Path Descriptor*	Waypoint Identifier	Fly Over	Course °M(^T)	Magnetic Variation	Distance (NM)	Turn Direction	Altitude (FT)	Speed (KIAS)	Vertical Angle	Navigation Specification
001	VA	—	—	337 (329.6)	-7.5	—	—	+600	—	—	RNAV1
002	DF	BOXER	Y	—	-7.5	—	—	—	—	—	RNAV1
003	TF	A4R21	—	337 (329.6)	-7.5	3.8	—	—	—	—	RNAV1
004	TF	A4R22	—	067 (059.3)	-7.5	4.1	—	—	—	—	RNAV1
005	TF	A4R23	—	112 (104.6)	-7.5	3.7	—	—	—	—	RNAV1
006	TF	PEGAS	—	141 (133.4)	-7.5	7.6	—	—	—	—	RNAV1
007	TF	LUCCA	—	157 (149.6)	-7.5	11.5	—	—	—	—	RNAV1
008	TF	CUPID	—	127 (119.8)	-7.5	24.2	—	—	—	—	RNAV1
009	TF	BORLO	—	119 (111.9)	-7.5	34.4	—	—	—	—	RNAV1

CHANGE : ALT Restriction on A4R23

STANDARD DEPARTURE CHART -INSTRUMENT

RJAA / NARITA INTL

RNAV SID

Waypoint Coordinates

Waypoint Identifier	Coordinates	Waypoint Identifier	Coordinates
A4L11	355915.6N / 1401249.1E	BEAMS	353533.0N / 1403153.1E
A4L12	360232.6N / 1401646.8E	BORLO	351633.8N / 1414455.6E
A4L13	360236.7N / 1402559.7E	BOXER	355213.0N / 1401951.6E
A4L14	355937.8N / 1403205.0E	CHUMS	354237.0N / 1404806.0E
A4R21	355529.4N / 1401729.2E	CUPID	352930.3N / 1410557.3E
A4R22	355734.5N / 1402150.1E	GRAYL	351504.8N / 1412938.0E
A4R23	355638.8N / 1402614.7E	LUCCA	354132.8N / 1404011.4E
A6L21	353137.9N / 1403441.9E	OLVAN	351214.1N / 1410111.3E
A6R12	352543.5N / 1403700.7E	PEGAS	355126.3N / 1403302.1E
ARIES	355607.4N / 1401505.9E	ROONY	355317.4N / 1404024.4E
ASPEN	353451.0N / 1403028.1E		

CHANGE : New PROC

STANDARD DEPARTURE CHART -INSTRUMENT

RJAA / NARITA INTL

RNAV SID

PEDLA ONE DEPARTURE		RNAV1
Note 1) DME/DME/IRU or GNSS required. ※The aircraft equipped with only DME/DME/IRU must be able to update its position without delay at the starting point of take-off rolling. 2) RADAR service required.	Critical DME	RWY16R:TLD DER – 1.3NM FM DER RWY16L:TLD DER – 3.4NM FM DER
	DME GAP	RWY34L :DER – 1.3NM FM DER
	Inappropriate Navaids	See AD1.1.6.10.3.Inappropriate NAVAIDs for RNAV1

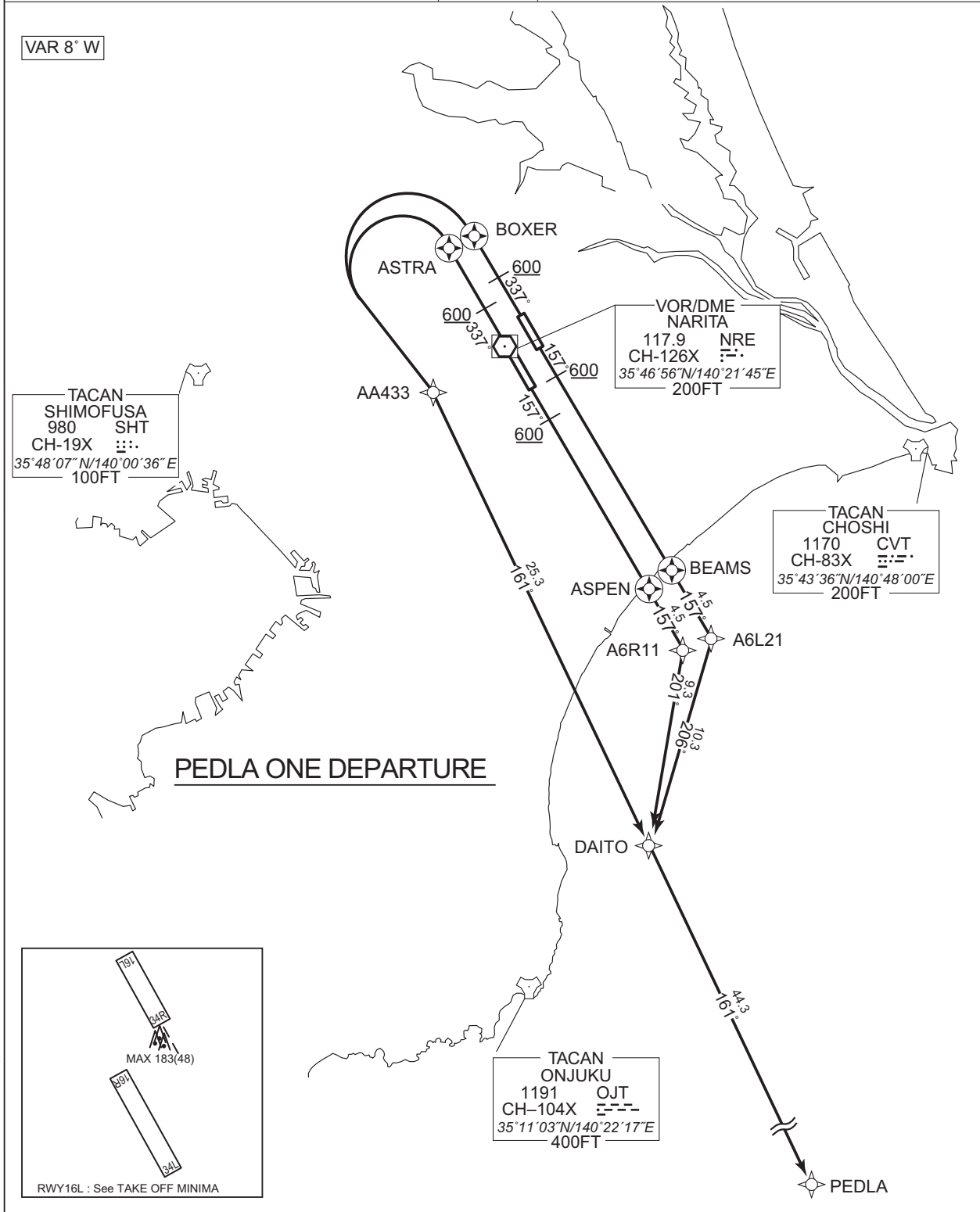

VAR 8° W

TACAN SHIMOFUSA
980 SHT
CH-19X
35°48'07"N/140°00'36"E
100FT

VOR/DME NARITA
117.9 NRE
CH-126X
35°46'56"N/140°21'45"E
200FT

TACAN CHOSHI
1170 CVT
CH-83X
35°43'36"N/140°48'00"E
200FT

TACAN ONJUKU
1191 OJT
CH-104X
35°11'03"N/140°22'17"E
400FT

CHANGE : Description of VAR.

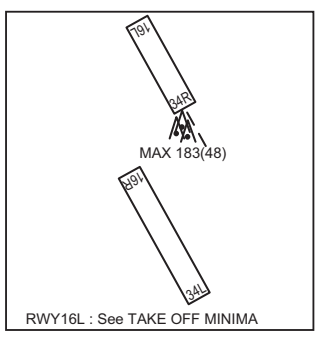

STANDARD DEPARTURE CHART -INSTRUMENT

RJAA / NARITA INTL

RNAV SID

PEDLA ONE DEPARTURE

RWY16R : Climb on HDG 157° at or above 600FT, direct to ASPEN, to A6R11, to DAITO, to PEDLA.

RWY16L : Climb on HDG 157° at or above 600FT, direct to BEAMS, to A6L21, to DAITO, to PEDLA.

RWY34L : Climb on HDG 337° at or above 600FT, direct to ASTRA, turn left direct to AA433, to DAITO, to PEDLA.

RWY34R : Climb on HDG 337° at or above 600FT, direct to BOXER, turn left direct to AA433, to DAITO, to PEDLA.

RWY16R

Serial Number	Path Descriptor	Waypoint Identifier	Fly Over	Course °M(°T)	Magnetic Variation	Distance (NM)	Turn Direction	Altitude (FT)	Speed (KIAS)	Vertical Angle	Navigation Specification
001	VA	-	-	157 (149.6)	-7.5	-	-	+600	-	-	RNAV1
002	DF	ASPEN	Y	-	-7.5	-	-	-	-	-	RNAV1
003	TF	A6R11	-	157 (149.7)	-7.5	4.5	-	-	-	-	RNAV1
004	TF	DAITO	-	201 (193.3)	-7.5	9.3	-	-	-	-	RNAV1
005	TF	PEDLA	-	161 (153.9)	-7.5	44.3	-	-	-	-	RNAV1

RWY16L

Serial Number	Path Descriptor	Waypoint Identifier	Fly Over	Course °M(°T)	Magnetic Variation	Distance (NM)	Turn Direction	Altitude (FT)	Speed (KIAS)	Vertical Angle	Navigation Specification
001	VA	-	-	157 (149.6)	-7.5	-	-	+600	-	-	RNAV1
002	DF	BEAMS	Y	-	-7.5	-	-	-	-	-	RNAV1
003	TF	A6L21	-	157 (149.7)	-7.5	4.5	-	-	-	-	RNAV1
004	TF	DAITO	-	206 (198.7)	-7.5	10.3	-	-	-	-	RNAV1
005	TF	PEDLA	-	161 (153.9)	-7.5	44.3	-	-	-	-	RNAV1

CHANGE : New PROC

STANDARD DEPARTURE CHART -INSTRUMENT

RJAA / NARITA INTL

RNAV SID

RWY34L

Serial Number	Path Descriptor	Waypoint Identifier	Fly Over	Course °M(°T)	Magnetic Variation	Distance (NM)	Turn Direction	Altitude (FT)	Speed (KIAS)	Vertical Angle	Navigation Specification
001	VA	-	-	337 (329.6)	-7.5	-	-	+600	-	-	RNAV1
002	DF	ASTRA	Y	-	-7.5	-	-	-	-	-	RNAV1
003	DF	AA433	-	-	-7.5	-	L	-	-	-	RNAV1
004	TF	DAITO	-	161 (153.9)	-7.5	25.3	-	-	-	-	RNAV1
005	TF	PEDLA	-	161 (153.9)	-7.5	44.3	-	-	-	-	RNAV1

RWY34R

Serial Number	Path Descriptor	Waypoint Identifier	Fly Over	Course °M(°T)	Magnetic Variation	Distance (NM)	Turn Direction	Altitude (FT)	Speed (KIAS)	Vertical Angle	Navigation Specification
001	VA	-	-	337 (329.6)	-7.5	-	-	+600	-	-	RNAV1
002	DF	BOXER	Y	-	-7.5	-	-	-	-	-	RNAV1
003	DF	AA433	-	-	-7.5	-	L	-	-	-	RNAV1
004	TF	DAITO	-	161 (153.9)	-7.5	25.3	-	-	-	-	RNAV1
005	TF	PEDLA	-	161 (153.9)	-7.5	44.3	-	-	-	-	RNAV1

Waypoint Coordinates

Waypoint Identifier	Coordinates	Waypoint Identifier	Coordinates
AA433	354438.5N / 1401700.8E	BEAMS	353533.0N / 1403153.1E
A6L21	353137.9N / 1403441.9E	BOXER	355213.0N / 1401951.6E
A6R11	353056.9N / 1403316.2E	DAITO	352153.6N / 1403039.0E
ASPEN	353451.0N / 1403028.1E	PEDLA	344203.7N / 1405420.5E
ASTRA	355207.1N / 1401800.2E		

CHANGE : New PROC

STANDARD DEPARTURE CHART -INSTRUMENT

RJAA / NARITA INTL

RNAV SID

OLVAN TWO DEPARTURE		RNAV1
Note 1) DME/DME/IRU or GNSS required. ※The aircraft equipped with only DME/DME/IRU must be able to update its position without delay at the starting point of take-off rolling. 2) RADAR service required.	Critical DME	RWY16R:TLD DER – 1.3NM FM DER RWY16L:TLD DER – 3.4NM FM DER
	DME GAP	RWY34L :DER – 1.3NM FM DER
	Inappropriate Nav aids	See AD1.1.6.10.3.Inappropriate NAVAIDs for RNAV1

VAR 8° W

OLVAN TWO DEPARTURE

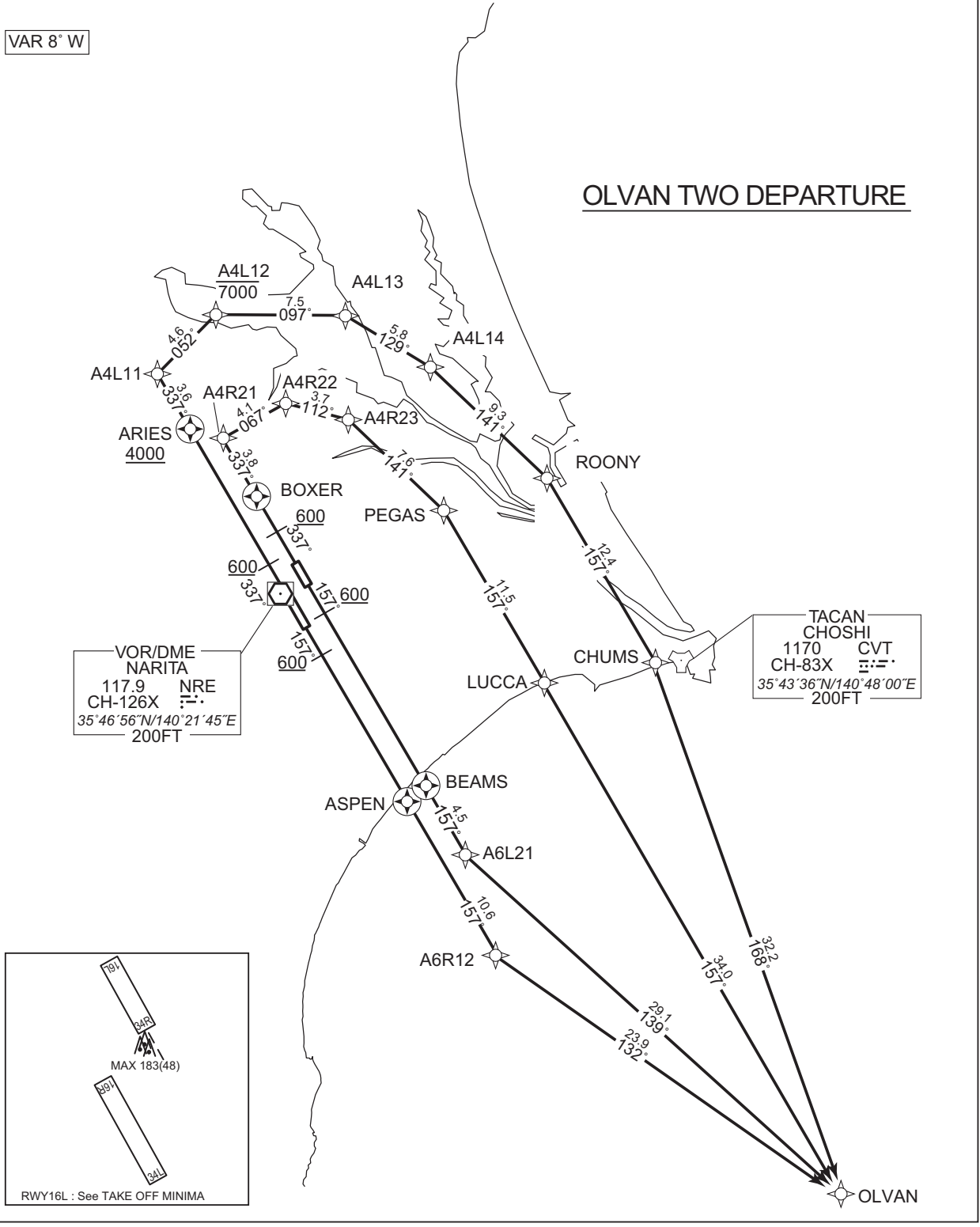

CHANGE : Description of VAR.

STANDARD DEPARTURE CHART -INSTRUMENT

RJAA / NARITA INTL

RNAV SID

OLVAN TWO DEPARTURE

RWY16R : Climb on HDG 157° at or above 600FT, direct to ASPEN, to A6R12, to OLVAN.

RWY16L : Climb on HDG 157° at or above 600FT, direct to BEAMS, to A6L21, to OLVAN.

RWY34L : Climb on HDG 337° at or above 600FT, direct to ARIES at or above 4000FT, to A4L11, to A4L12 at or below 7000FT, to A4L13, to A4L14, to ROONY, to CHUMS, to OLVAN.

RWY34R : Climb on HDG 337° at or above 600FT, direct to BOXER, to A4R21, to A4R22, to A4R23, to PEGAS, to LUCCA, to OLVAN.

RWY16R *MUST be used for database coding.

Serial Number	Path Descriptor*	Waypoint Identifier	Fly Over	Course °M(°T)	Magnetic Variation	Distance (NM)	Turn Direction	Altitude (FT)	Speed (KIAS)	Vertical Angle	Navigation Specification
001	VA	-	-	157 (149.6)	-7.5	-	-	+600	-	-	RNAV1
002	DF	ASPEN	Y	-	-7.5	-	-	-	-	-	RNAV1
003	TF	A6R12	-	157 (149.7)	-7.5	10.6	-	-	-	-	RNAV1
004	TF	OLVAN	-	132 (124.2)	-7.5	23.9	-	-	-	-	RNAV1

RWY16L *MUST be used for database coding.

Serial Number	Path Descriptor*	Waypoint Identifier	Fly Over	Course °M(°T)	Magnetic Variation	Distance (NM)	Turn Direction	Altitude (FT)	Speed (KIAS)	Vertical Angle	Navigation Specification
001	VA	-	-	157 (149.6)	-7.5	-	-	+600	-	-	RNAV1
002	DF	BEAMS	Y	-	-7.5	-	-	-	-	-	RNAV1
003	TF	A6L21	-	157 (149.7)	-7.5	4.5	-	-	-	-	RNAV1
004	TF	OLVAN	-	139 (131.8)	-7.5	29.1	-	-	-	-	RNAV1

CHANGE : ALT Restriction on A4R23. PROC renamed.

STANDARD DEPARTURE CHART -INSTRUMENT

RJAA / NARITA INTL

RNAV SID

RWY34L *MUST be used for database coding.

Serial Number	Path Descriptor*	Waypoint Identifier	Fly Over	Course °M(^T)	Magnetic Variation	Distance (NM)	Turn Direction	Altitude (FT)	Speed (KIAS)	Vertical Angle	Navigation Specification
001	VA	-	-	337 (329.6)	-7.5	-	-	+600	-	-	RNAV1
002	DF	ARIES	Y	-	-7.5	-	-	+4000	-	-	RNAV1
003	TF	A4L11	-	337 (329.5)	-7.5	3.6	-	-	-	-	RNAV1
004	TF	A4L12	-	052 (044.3)	-7.5	4.6	-	-7000	-	-	RNAV1
005	TF	A4L13	-	097 (089.4)	-7.5	7.5	-	-	-	-	RNAV1
006	TF	A4L14	-	129 (121.2)	-7.5	5.8	-	-	-	-	RNAV1
007	TF	ROONY	-	141 (133.2)	-7.5	9.3	-	-	-	-	RNAV1
008	TF	CHUMS	-	157 (149.7)	-7.5	12.4	-	-	-	-	RNAV1
009	TF	OLVAN	-	168 (160.6)	-7.5	32.2	-	-	-	-	RNAV1

RWY34R *MUST be used for database coding.

Serial Number	Path Descriptor*	Waypoint Identifier	Fly Over	Course °M(^T)	Magnetic Variation	Distance (NM)	Turn Direction	Altitude (FT)	Speed (KIAS)	Vertical Angle	Navigation Specification
001	VA	-	-	337 (329.6)	-7.5	-	-	+600	-	-	RNAV1
002	DF	BOXER	Y	-	-7.5	-	-	-	-	-	RNAV1
003	TF	A4R21	-	337 (329.6)	-7.5	3.8	-	-	-	-	RNAV1
004	TF	A4R22	-	067 (059.3)	-7.5	4.1	-	-	-	-	RNAV1
005	TF	A4R23	-	112 (104.6)	-7.5	3.7	-	-	-	-	RNAV1
006	TF	PEGAS	-	141 (133.4)	-7.5	7.6	-	-	-	-	RNAV1
007	TF	LUCCA	-	157 (149.6)	-7.5	11.5	-	-	-	-	RNAV1
008	TF	OLVAN	-	157 (149.6)	-7.5	34.0	-	-	-	-	RNAV1

Waypoint Coordinates

Waypoint Identifier	Coordinates	Waypoint Identifier	Coordinates
A4L11	355915.6N / 1401249.1E	ARIES	355607.4N / 1401505.9E
A4L12	360232.6N / 1401646.8E	ASPEN	353451.0N / 1403028.1E
A4L13	360236.7N / 1402559.7E	BEAMS	353533.0N / 1403153.1E
A4L14	355937.8N / 1403205.0E	BOXER	355213.0N / 1401951.6E
A4R21	355529.4N / 1401729.2E	CHUMS	354237.0N / 1404806.0E
A4R22	355734.5N / 1402150.1E	LUCCA	354132.8N / 1404011.4E
A4R23	355638.8N / 1402614.7E	OLVAN	351214.1N / 1410111.3E
A6L21	353137.9N / 1403441.9E	PEGAS	355126.3N / 1403302.1E
A6R12	352543.5N / 1403700.7E	ROONY	355317.4N / 1404024.4E

CHANGE : ALT Restriction on A4R23

STANDARD DEPARTURE CHART -INSTRUMENT

RJAA / NARITA INTL

RNAV TRANSITION

SAMUS TRANSITION		RNAV1
Note 1) DME/DME/IRU or GNSS required. 2) RADAR service required.	Critical DME	-
	DME GAP	-
	Inappropriate Nav aids	See AD1.1.6.10.3.Inappropriate NAVAIDs for RNAV1

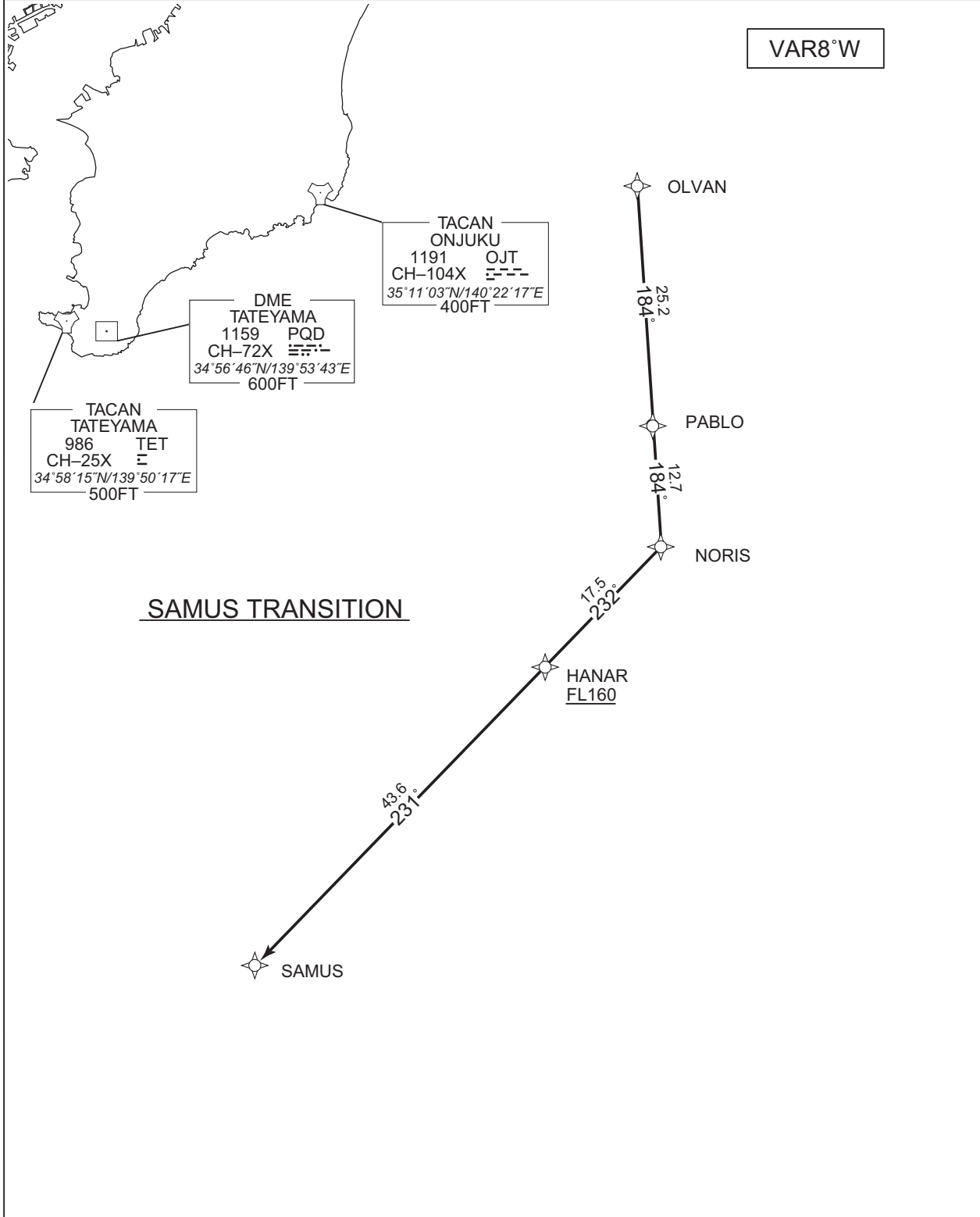

CHANGE : Description of VAR.

STANDARD DEPARTURE CHART -INSTRUMENT

RJAA / NARITA INTL

RNAV TRANSITION

SAMUS TRANSITION

From OLVAN, to PABLO, to NORIS, to HANAR at or above FL160, to SAMUS.

Serial Number	Path Descriptor	Waypoint Identifier	Fly Over	Course °M(°T)	Magnetic Variation	Distance (NM)	Turn Direction	Altitude (FT)	Speed (KIAS)	Vertical Angle	Navigation Specification
001	IF	OLVAN	-	-	-7.5	-	-	-	-	-	RNAV1
002	TF	PABLO	-	184 (176.3)	-7.5	25.2	-	-	-	-	RNAV1
003	TF	NORIS	-	184 (176.3)	-7.5	12.7	-	-	-	-	RNAV1
004	TF	HANAR	-	232 (224.0)	-7.5	17.5	-	+FL160	-	-	RNAV1
005	TF	SAMUS	-	231 (223.8)	-7.5	43.6	-	-	-	-	RNAV1

Waypoint Coordinates

Waypoint Identifier	Coordinates	Waypoint Identifier	Coordinates
HANAR	342149.9N / 1404923.3E	PABLO	344705.1N / 1410309.6E
NORIS	343426.6N / 1410408.5E	SAMUS	335020.0N / 1401305.0E
OLVAN	351214.1N / 1410111.3E		

CHANGE : New PROC

INTENTIONALLY LEFT BLANK

STANDARD ARRIVAL CHART -INSTRUMENT

RJAA / NARITA INTL

STAR

CHANGE : BOSPA SOUTH ALFA/BRAVO ARRIVAL established. ABBOT SOUTH ALFA/BRAVO ARRIVAL abolished.
BINKS SOUTH BRAVO ARRIVAL. SWAMP SOUTH ALFA/BRAVO ARRIVAL.

BOSPA SOUTH ALFA ARRIVAL

From over BOSPA, via NRE R095 to SIMAK, via NRE 21.0DME clockwise ARC to intercept and proceed via NRE R157 to GIINA.

Cross BOSPA at or above 8000FT, cross GIINA at 4000FT.

BOSPA SOUTH BRAVO ARRIVAL

From over BOSPA, via NRE R095 to SIMAK, via NRE 21.0DME clockwise ARC to intercept and proceed via NRE R153 to TEMIS.

Cross BOSPA at or above 8000FT, cross TEMIS at or above 5000FT.

BINKS SOUTH ALFA ARRIVAL

From over BINKS, via HDG007° to intercept and proceed via NRE R157 to GIINA.

Cross GIINA at 4000FT.

BINKS SOUTH BRAVO ARRIVAL

From over BINKS, via HDG007° to intercept and proceed via NRE R153 to TEMIS.

Cross TEMIS at or above 5000FT.

SWAMP SOUTH ALFA ARRIVAL

From over SWAMP, via NRE R022 to DANTE, via NRE 21.0DME clockwise ARC to intercept and proceed via NRE R157 to GIINA via SIMAK.

Cross DANTE at or above 11000FT, cross SIMAK at or above 9000FT, cross GIINA at 4000FT.

SWAMP SOUTH BRAVO ARRIVAL

From over SWAMP, via NRE R022 to DANTE, via NRE 21.0DME clockwise ARC to intercept and proceed via NRE R153 to TEMIS via SIMAK.

Cross DANTE at or above 11000FT, cross SIMAK at or above 9000FT, cross TEMIS at or above 5000FT.

STANDARD ARRIVAL CHART -INSTRUMENT

RJAA / NARITA INTL

STAR RWY34L/34R

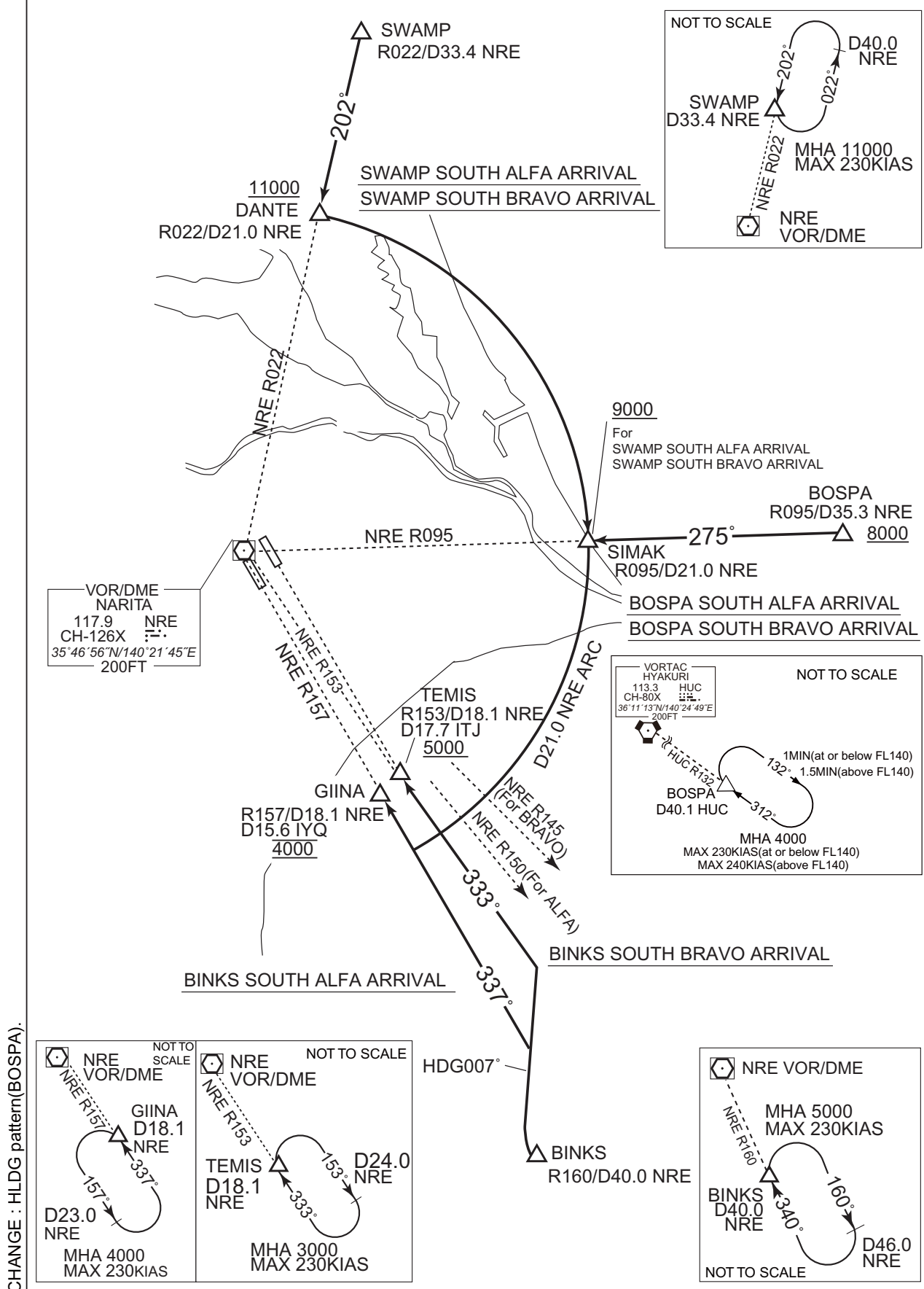

STANDARD ARRIVAL CHART -INSTRUMENT

RJAA / NARITA INTL

STAR

CHANGE : BOSPA NORTH ARRIVAL established. ABBOT NORTH ARRIVAL abolished. BINKS NORTH ARRIVAL. LAKES NORTH ARRIVAL.

BOSPA NORTH ARRIVAL

From over BOSPA, via NRE R095 to intercept and proceed via NRE 12.8DME counterclockwise ARC to LAKES.

Cross BOSPA at or above 8000FT, cross LAKES at or above 6000FT.

BINKS NORTH ARRIVAL

From over BINKS, via NRE R160 to intercept and proceed via NRE 21.0DME counterclockwise ARC to SIMAK, via NRE R095 to intercept and proceed via NRE 12.8DME counterclockwise ARC to LAKES.

Cross LAKES at or above 6000FT.

LAKES NORTH ARRIVAL

From over SWAMP, via NRE R022 to DANTE, via NRE 21.0DME clockwise ARC to SIMAK, via NRE R095 to intercept and proceed via NRE 12.8DME counterclockwise ARC to LAKES.

Cross DANTE at or above 11000FT, cross SIMAK at or above 9000FT, cross LAKES at or above 6000FT.

STANDARD ARRIVAL CHART -INSTRUMENT

RJAA / NARITA INTL

STAR RWY16R/16L

CHANGE : HLDG pattern(BOSPA).

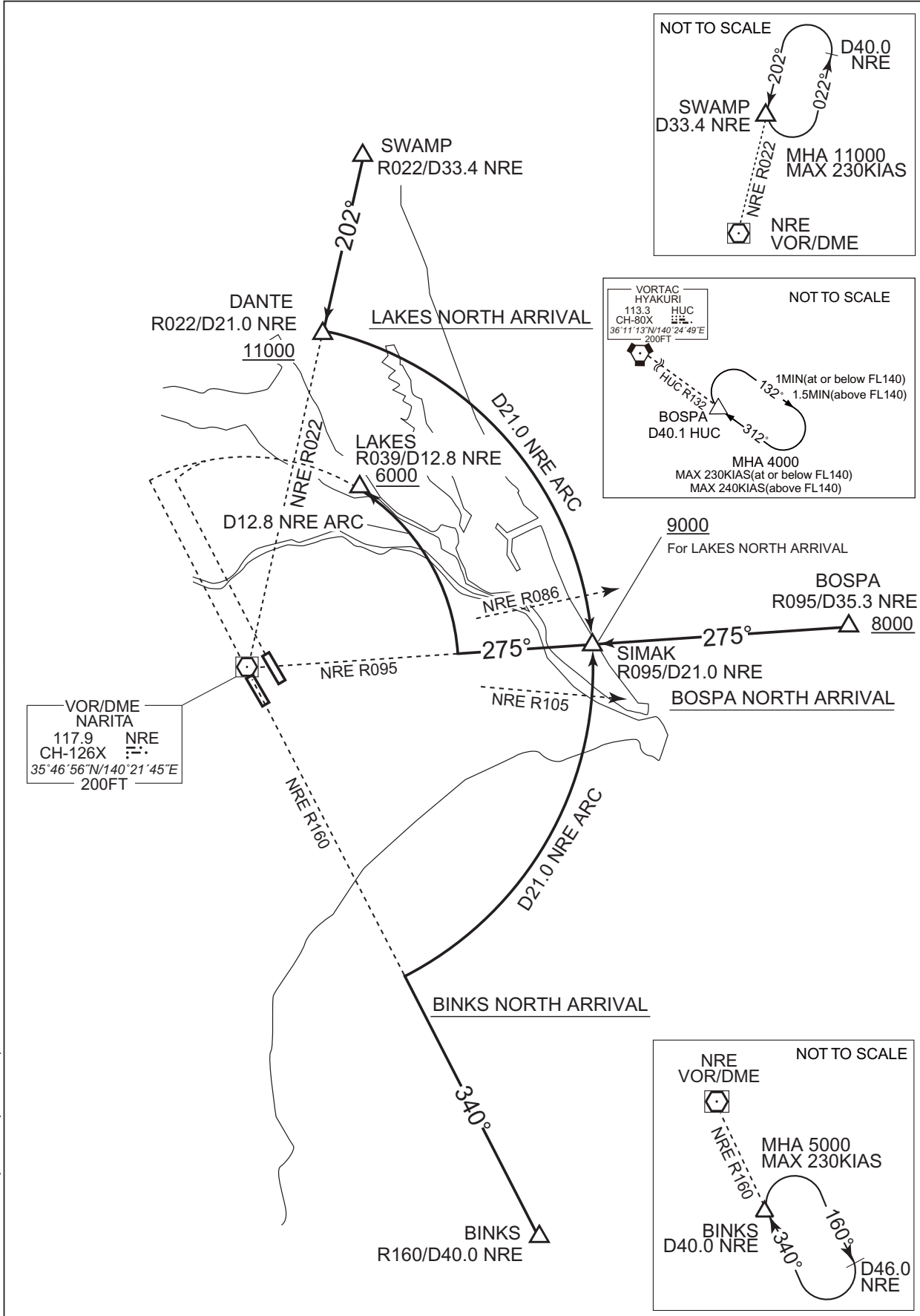

STANDARD ARRIVAL CHART - INSTRUMENT

RJAA / NARITA INTL

RNAV STAR RWY34L/34R

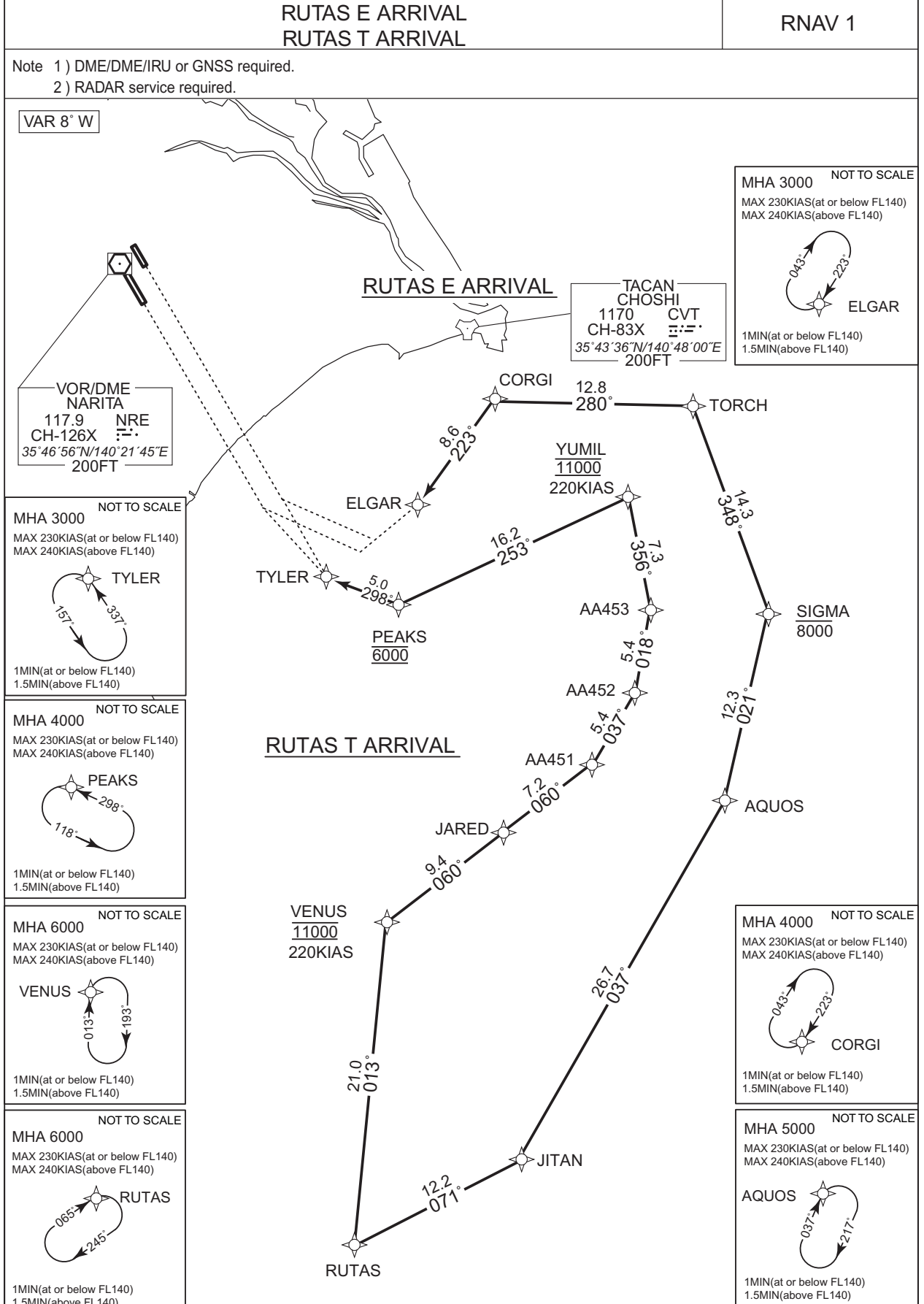

CHANGE: Description of HLDG pattern.

STANDARD ARRIVAL CHART - INSTRUMENT

RJAA / NARITA INTL

RNAV STAR RWY34L/34R

RUTAS E ARRIVAL

From RUTAS, to JITAN, to AQUOS, to SIGMA at or below 8000FT, to TORCH, to CORGI, to ELGAR.

Critical DME	-
DME GAP	-
Inappropriate Nav aids	See AD1.1.6.10.3. Inappropriate NAVAIDs for RNAV1

Serial Number	Path Descriptor	Waypoint Identifier	Fly Over	Course °M(°T)	Magnetic Variation	Distance (NM)	Turn Direction	Altitude (FT)	Speed (KIAS)	Vertical Angle	Navigation Specification
001	IF	RUTAS	-	-	-7.5	-	-	-	-	-	RNAV1
002	TF	JITAN	-	071 (063.5)	-7.5	12.2	-	-	-	-	RNAV1
003	TF	AQUOS	-	037 (029.1)	-7.5	26.7	-	-	-	-	RNAV1
004	TF	SIGMA	-	021 (013.8)	-7.5	12.3	-	-8000	-	-	RNAV1
005	TF	TORCH	-	348 (340.3)	-7.5	14.3	-	-	-	-	RNAV1
006	TF	CORGI	-	280 (272.8)	-7.5	12.8	-	-	-	-	RNAV1
007	TF	ELGAR	-	223 (215.7)	-7.5	8.6	-	-	-	-	RNAV1

Path	Waypoint Identifier	Inbound Course °M(°T)	Magnetic Variation	Outbound Time (MIN)	Outbound Distance (NM)	Turn Direction	Minimum Altitude (FT)	Maximum Altitude (FT)	Speed (KIAS)	Navigation Specification
Hold	RUTAS	065 (057.9)	-7.5	1.0(-14000) 1.5(+14001)	-	R	6000	-	-230(-14000) -240(+14001)	RNAV1
Hold	AQUOS	037 (029.1)	-7.5	1.0(-14000) 1.5(+14001)	-	R	5000	-	-230(-14000) -240(+14001)	RNAV1
Hold	CORGI	223 (215.8)	-7.5	1.0(-14000) 1.5(+14001)	-	R	4000	-	-230(-14000) -240(+14001)	RNAV1
Hold	ELGAR	223 (215.7)	-7.5	1.0(-14000) 1.5(+14001)	-	R	3000	-	-230(-14000) -240(+14001)	RNAV1

CHANGE : New PROC

STANDARD ARRIVAL CHART - INSTRUMENT

RJAA / NARITA INTL

RNAV STAR RWY34L/34R

RUTAS T ARRIVAL

From RUTAS, to VENUS at 11000FT, to JARED, to AA451, to AA452, to AA453, to YUMIL at 11000FT, to PEAKS at 6000FT, to TYLER.

Critical DME	-
DME GAP	-
Inappropriate NavAids	See AD1.1.6.10.3. Inappropriate NAVAIDs for RNAV1

Serial Number	Path Descriptor	Waypoint Identifier	Fly Over	Course °M(°T)	Magnetic Variation	Distance (NM)	Turn Direction	Altitude (FT)	Speed (KIAS)	Vertical Angle	Navigation Specification
001	IF	RUTAS	-	-	-7.5	-	-	-	-	-	RNAV1
002	TF	VENUS	-	013 (005.8)	-7.5	21.0	-	11000	220	-	RNAV1
003	TF	JARED	-	060 (052.3)	-7.5	9.4	-	-	-	-	RNAV1
004	TF	AA451	-	060 (052.1)	-7.5	7.2	-	-	-	-	RNAV1
005	TF	AA452	-	037 (029.7)	-7.5	5.4	-	-	-	-	RNAV1
006	TF	AA453	-	018 (010.7)	-7.5	5.4	-	-	-	-	RNAV1
007	TF	YUMIL	-	356 (348.2)	-7.5	7.3	-	11000	220	-	RNAV1
008	TF	PEAKS	-	253 (245.0)	-7.5	16.2	-	6000	-	-	RNAV1
009	TF	TYLER	-	298 (290.2)	-7.5	5.0	-	-	-	-	RNAV1

Path	Waypoint Identifier	Inbound Course °M(°T)	Magnetic Variation	Outbound Time (MIN)	Outbound Distance (NM)	Turn Direction	Minimum Altitude (FT)	Maximum Altitude (FT)	Speed (KIAS)	Navigation Specification
Hold	RUTAS	065 (057.9)	-7.5	1.0(-14000) 1.5(+14001)	-	R	6000	-	-230(-14000) -240(+14001)	RNAV1
Hold	VENUS	013 (005.8)	-7.5	1.0(-14000) 1.5(+14001)	-	R	6000	-	-230(-14000) -240(+14001)	RNAV1
Hold	PEAKS	298 (290.2)	-7.5	1.0(-14000) 1.5(+14001)	-	L	4000	-	-230(-14000) -240(+14001)	RNAV1
Hold	TYLER	337 (329.8)	-7.5	1.0(-14000) 1.5(+14001)	-	L	3000	-	-230(-14000) -240(+14001)	RNAV1

CHANGE: JARED renamed. HLDG Pattern (PEAKS) established.

STANDARD ARRIVAL CHART - INSTRUMENT

RJAA / NARITA INTL

RNAV STAR RWY34L/34R

Waypoint Coordinates

Waypoint Identifier	Coordinates	Waypoint Identifier	Coordinates
AA451	351449.2N / 1405911.3E	PEAKS	352507.2N / 1404352.7E
AA452	351930.7N / 1410228.5E	RUTAS	344349.3N / 1404034.2E
AA453	352449.7N / 1410342.2E	SIGMA	352425.5N / 1411318.3E
AQUOS	351229.7N / 1410942.5E	TORCH	353752.8N / 1410721.7E
CORGI	353829.8N / 1405138.9E	TYLER	352650.5N / 1403807.8E
ELGAR	353129.2N / 1404527.4E	VENUS	350440.1N / 1404309.7E
JARED	351024.8N / 1405215.4E	YUMIL	353158.6N / 1410151.7E
JITAN	344914.2N / 1405349.3E		

CHANGE: JARED renamed

STANDARD ARRIVAL CHART - INSTRUMENT

RJAA / NARITA INTL

RNAV STAR RWY34L/34R

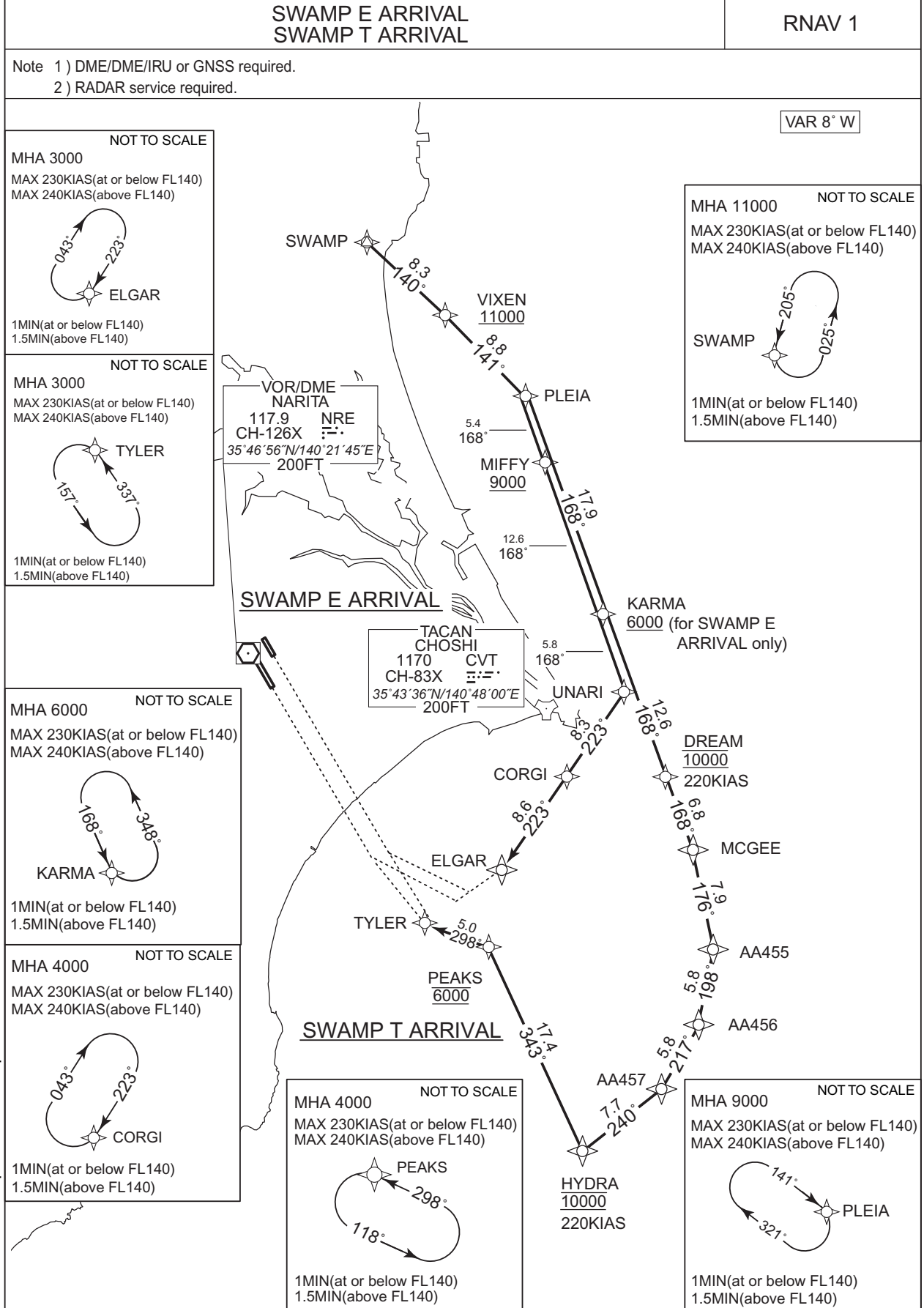

STANDARD ARRIVAL CHART - INSTRUMENT

RJAA / NARITA INTL

RNAV STAR RWY34L/34R

SWAMP E ARRIVAL

From SWAMP, to VIXEN at or above 11000FT, to PLEIA, to MIFFY at or above 9000FT, to KARMA at or above 6000FT, to UNARI, to CORGI, to ELGAR.

Critical DME	-
DME GAP	-
Inappropriate Navaids	See AD1.1.6.10.3. Inappropriate NAVAIDs for RNAV1

Serial Number	Path Descriptor	Waypoint Identifier	Fly Over	Course °M(°T)	Magnetic Variation	Distance (NM)	Turn Direction	Altitude (FT)	Speed (KIAS)	Vertical Angle	Navigation Specification
001	IF	SWAMP	-	-	-7.5	-	-	-	-	-	RNAV1
002	TF	VIXEN	-	140 (133.0)	-7.5	8.3	-	+11000	-	-	RNAV1
003	TF	PLEIA	-	141 (133.0)	-7.5	8.8	-	-	-	-	RNAV1
004	TF	MIFFY	-	168 (160.3)	-7.5	5.4	-	+9000	-	-	RNAV1
005	TF	KARMA	-	168 (160.3)	-7.5	12.6	-	+6000	-	-	RNAV1
006	TF	UNARI	-	168 (160.4)	-7.5	5.8	-	-	-	-	RNAV1
007	TF	CORGI	-	223 (215.8)	-7.5	8.3	-	-	-	-	RNAV1
008	TF	ELGAR	-	223 (215.7)	-7.5	8.6	-	-	-	-	RNAV1

Path	Waypoint Identifier	Inbound Course °M(°T)	Magnetic Variation	Outbound Time (MIN)	Outbound Distance (NM)	Turn Direction	Minimum Altitude (FT)	Maximum Altitude (FT)	Speed (KIAS)	Navigation Specification
Hold	SWAMP	205 (197.0)	-7.5	1.0(-14000) 1.5(+14001)	-	L	11000	-	-230(-14000) -240(+14001)	RNAV1
Hold	PLEIA	141 (133.1)	-7.5	1.0(-14000) 1.5(+14001)	-	R	9000	-	-230(-14000) -240(+14001)	RNAV1
Hold	KARMA	168 (160.3)	-7.5	1.0(-14000) 1.5(+14001)	-	L	6000	-	-230(-14000) -240(+14001)	RNAV1
Hold	CORGI	223 (215.8)	-7.5	1.0(-14000) 1.5(+14001)	-	R	4000	-	-230(-14000) -240(+14001)	RNAV1
Hold	ELGAR	223 (215.7)	-7.5	1.0(-14000) 1.5(+14001)	-	R	3000	-	-230(-14000) -240(+14001)	RNAV1

CHANGE : New PROC

STANDARD ARRIVAL CHART - INSTRUMENT

RJAA / NARITA INTL

RNAV STAR RWY34L/34R

SWAMP T ARRIVAL

From SWAMP, to VIXEN at or above 11000FT, to PLEIA, to KARMA, to DREAM at 10000FT, to MCGEE, to AA455, to AA456, to AA457, to HYDRA at 10000FT, to PEAKS at 6000FT, to TYLER.

Critical DME	-
DME GAP	-
Inappropriate Navaids	See AD1.1.6.10.3. Inappropriate NAVAIDs for RNAV1

Serial Number	Path Descriptor	Waypoint Identifier	Fly Over	Course °M(°T)	Magnetic Variation	Distance (NM)	Turn Direction	Altitude (FT)	Speed (KIAS)	Vertical Angle	Navigation Specification
001	IF	SWAMP	-	-	-7.5	-	-	-	-	-	RNAV1
002	TF	VIXEN	-	140 (133.0)	-7.5	8.3	-	+11000	-	-	RNAV1
003	TF	PLEIA	-	141 (133.0)	-7.5	8.8	-	-	-	-	RNAV1
004	TF	KARMA	-	168 (160.3)	-7.5	17.9	-	-	-	-	RNAV1
005	TF	DREAM	-	168 (160.4)	-7.5	12.6	-	10000	220	-	RNAV1
006	TF	MCGEE	-	168 (160.4)	-7.5	6.8	-	-	-	-	RNAV1
007	TF	AA455	-	176 (168.2)	-7.5	7.9	-	-	-	-	RNAV1
008	TF	AA456	-	198 (190.7)	-7.5	5.8	-	-	-	-	RNAV1
009	TF	AA457	-	217 (209.8)	-7.5	5.8	-	-	-	-	RNAV1
010	TF	HYDRA	-	240 (232.1)	-7.5	7.7	-	10000	220	-	RNAV1
011	TF	PEAKS	-	343 (335.1)	-7.5	17.4	-	6000	-	-	RNAV1
012	TF	TYLER	-	298 (290.2)	-7.5	5.0	-	-	-	-	RNAV1

Path	Waypoint Identifier	Inbound Course °M(°T)	Magnetic Variation	Outbound Time (MIN)	Outbound Distance (NM)	Turn Direction	Minimum Altitude (FT)	Maximum Altitude (FT)	Speed (KIAS)	Navigation Specification
Hold	SWAMP	205 (197.0)	-7.5	1.0(-14000) 1.5(+14001)	-	L	11000	-	-230(-14000) -240(+14001)	RNAV1
Hold	PLEIA	141 (133.1)	-7.5	1.0(-14000) 1.5(+14001)	-	R	9000	-	-230(-14000) -240(+14001)	RNAV1
Hold	KARMA	168 (160.3)	-7.5	1.0(-14000) 1.5(+14001)	-	L	6000	-	-230(-14000) -240(+14001)	RNAV1
Hold	PEAKS	298 (290.2)	-7.5	1.0(-14000) 1.5(+14001)	-	L	4000	-	-230(-14000) -240(+14001)	RNAV1
Hold	TYLER	337 (329.8)	-7.5	1.0(-14000) 1.5(+14001)	-	L	3000	-	-230(-14000) -240(+14001)	RNAV1

CHANGE: MCGEE renamed. HLDG Pattern (PEAKS) established.

STANDARD ARRIVAL CHART - INSTRUMENT

RJAA / NARITA INTL

RNAV STAR RWY34L/34R

Waypoint Coordinates

Waypoint Identifier	Coordinates	Waypoint Identifier	Coordinates
AA455	352448.3N / 1410510.3E	MCGEE	353229.0N / 1410311.8E
AA456	351905.7N / 1410351.0E	MIFY	360232.1N / 1404959.5E
AA457	351403.4N / 1410019.2E	PEAKS	352507.2N / 1404352.7E
CORGI	353829.8N / 1405138.9E	PLEIA	360734.8N / 1404745.4E
DREAM	353853.3N / 1410023.9E	SWAMP	361914.4N / 1403217.0E
ELGAR	353129.2N / 1404527.4E	TYLER	352650.5N / 1403807.8E
HYDRA	350919.4N / 1405252.5E	UNARI	354513.8N / 1405737.1E
KARMA	355042.9N / 1405512.4E	VIXEN	361335.9N / 1403947.1E

CHANGE : MCGEE renamed

STANDARD ARRIVAL CHART - INSTRUMENT

RJAA / NARITA INTL

RNAV STAR RWY34L/34R

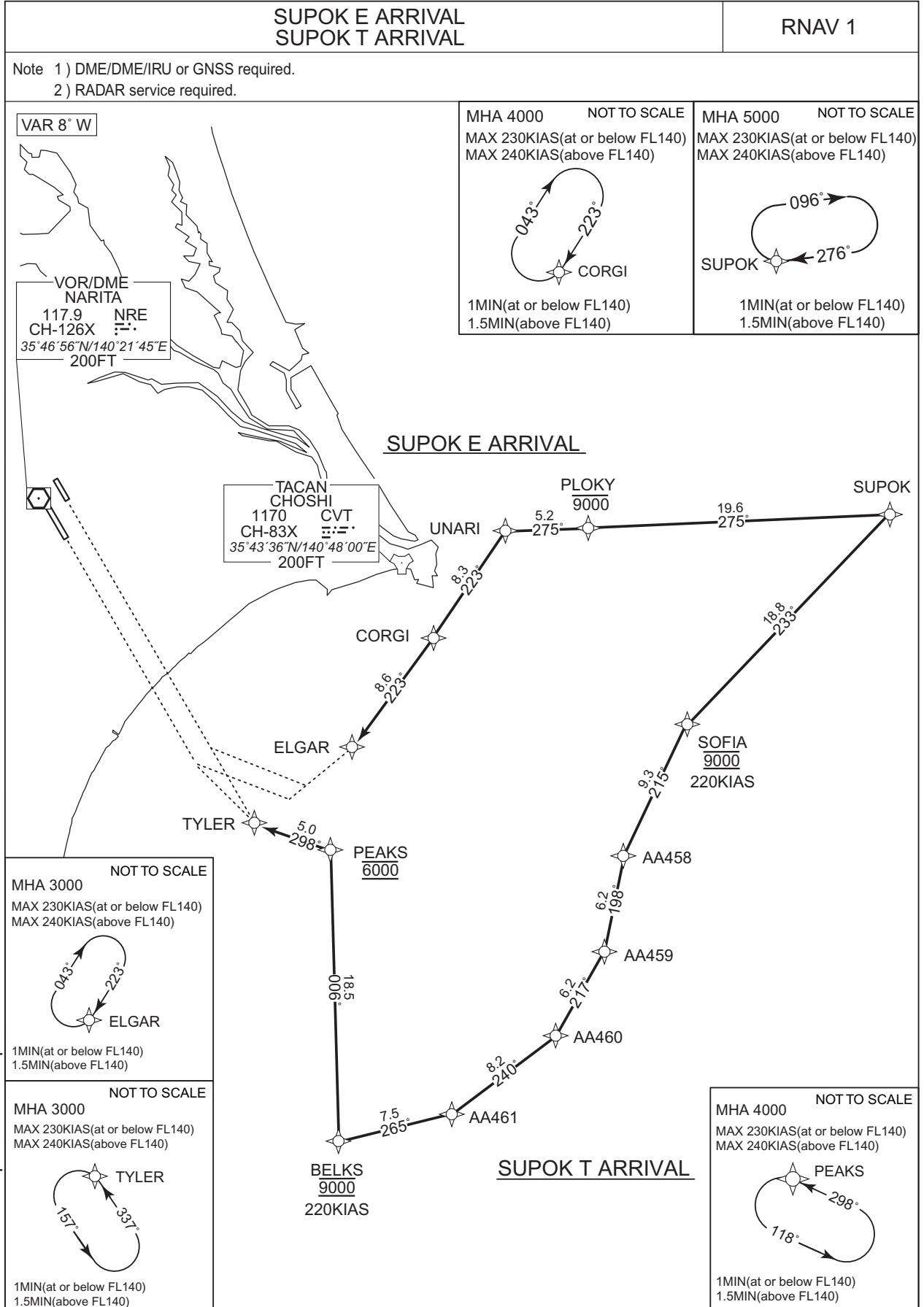

CHANGE : Description of HLDG pattern.

STANDARD ARRIVAL CHART - INSTRUMENT

RJAA / NARITA INTL

RNAV STAR RWY34L/34R

SUPOK E ARRIVAL

From SUPOK, to PLOKY at or below 9000FT, to UNARI, to CORGI, to ELGAR.

Critical DME	-
DME GAP	-
Inappropriate Nav aids	See AD1.1.6.10.3. Inappropriate NAVAIDs for RNAV1

Serial Number	Path Descriptor	Waypoint Identifier	Fly Over	Course °M(°T)	Magnetic Variation	Distance (NM)	Turn Direction	Altitude (FT)	Speed (KIAS)	Vertical Angle	Navigation Specification
001	IF	SUPOK	-	-	-7.5	-	-	-	-	-	RNAV1
002	TF	PLOKY	-	275 (267.9)	-7.5	19.6	-	-9000	-	-	RNAV1
003	TF	UNARI	-	275 (267.4)	-7.5	5.2	-	-	-	-	RNAV1
004	TF	CORGI	-	223 (215.8)	-7.5	8.3	-	-	-	-	RNAV1
005	TF	ELGAR	-	223 (215.7)	-7.5	8.6	-	-	-	-	RNAV1

Path	Waypoint Identifier	Inbound Course °M(°T)	Magnetic Variation	Outbound Time (MIN)	Outbound Distance (NM)	Turn Direction	Minimum Altitude (FT)	Maximum Altitude (FT)	Speed (KIAS)	Navigation Specification
Hold	SUPOK	276 (268.6)	-7.5	1.0(-14000) 1.5(+14001)	-	R	5000	-	-230(-14000) -240(+14001)	RNAV1
Hold	CORGI	223 (215.8)	-7.5	1.0(-14000) 1.5(+14001)	-	R	4000	-	-230(-14000) -240(+14001)	RNAV1
Hold	ELGAR	223 (215.7)	-7.5	1.0(-14000) 1.5(+14001)	-	R	3000	-	-230(-14000) -240(+14001)	RNAV1

CHANGE : New PROC

STANDARD ARRIVAL CHART - INSTRUMENT

RJAA / NARITA INTL

RNAV STAR RWY34L/34R

SUPOK T ARRIVAL

From SUPOK, to SOFIA at 9000FT, to AA458, to AA459, to AA460, to AA461, to BELKS at 9000FT, to PEAKS at 6000FT, to TYLER.

Critical DME	-
DME GAP	-
Inappropriate Navaids	See AD1.1.6.10.3. Inappropriate NAVAIDS for RNAV1

Serial Number	Path Descriptor	Waypoint Identifier	Fly Over	Course °M(°T)	Magnetic Variation	Distance (NM)	Turn Direction	Altitude (FT)	Speed (KIAS)	Vertical Angle	Navigation Specification
001	IF	SUPOK	-	-	-7.5	-	-	-	-	-	RNAV1
002	TF	SOFIA	-	233 (225.2)	-7.5	18.8	-	9000	220	-	RNAV1
003	TF	AA458	-	215 (207.2)	-7.5	9.3	-	-	-	-	RNAV1
004	TF	AA459	-	198 (190.7)	-7.5	6.2	-	-	-	-	RNAV1
005	TF	AA460	-	217 (209.8)	-7.5	6.2	-	-	-	-	RNAV1
006	TF	AA461	-	240 (232.2)	-7.5	8.2	-	-	-	-	RNAV1
007	TF	BELKS	-	265 (257.8)	-7.5	7.5	-	9000	220	-	RNAV1
008	TF	PEAKS	-	006 (358.3)	-7.5	18.5	-	6000	-	-	RNAV1
009	TF	TYLER	-	298 (290.2)	-7.5	5.0	-	-	-	-	RNAV1

Path	Waypoint Identifier	Inbound Course °M(°T)	Magnetic Variation	Outbound Time (MIN)	Outbound Distance (NM)	Turn Direction	Minimum Altitude (FT)	Maximum Altitude (FT)	Speed (KIAS)	Navigation Specification
Hold	SUPOK	276 (268.6)	-7.5	1.0(-14000) 1.5(+14001)	-	R	5000	-	-230(-14000) -240(+14001)	RNAV1
Hold	PEAKS	298 (290.2)	-7.5	1.0(-14000) 1.5(+14001)	-	L	4000	-	-230(-14000) -240(+14001)	RNAV1
Hold	TYLER	337 (329.8)	-7.5	1.0(-14000) 1.5(+14001)	-	L	3000	-	-230(-14000) -240(+14001)	RNAV1

Waypoint Coordinates

Waypoint Identifier	Coordinates	Waypoint Identifier	Coordinates
AA458	352446.9N / 1410638.5E	PEAKS	352507.2N / 1404352.7E
AA459	351840.7N / 1410513.6E	PLOKY	354528.3N / 1410402.3E
AA460	351317.5N / 1410127.0E	SOFIA	353300.1N / 1411149.9E
AA461	350814.0N / 1405329.6E	SUPOK	354614.1N / 1412810.0E
BELKS	350638.5N / 1404433.3E	TYLER	352650.5N / 1403807.8E
CORGI	353829.8N / 1405138.9E	UNARI	354513.8N / 1405737.1E
ELGAR	353129.2N / 1404527.4E		

CHANGE : HLDG Pattern (PEAKS) established

STANDARD ARRIVAL CHART - INSTRUMENT

RJAA / NARITA INTL

RNAV STAR RWY34L/34R

LUBLA E ARRIVAL
LUBLA T ARRIVAL

RNAV 1

Note 1) DME/DME/IRU or GNSS required.
2) RADAR service required.

VAR 8° W

VOR/DME
NARITA
117.9 NRE
CH-126X
35°46'56"N/140°21'45"E
200FT

TACAN
CHOSHI
1170 CVT
CH-83X
35°43'36"N/140°48'00"E
200FT

MHA 4000 NOT TO SCALE
MAX 230KIAS(at or below FL140)
MAX 240KIAS(above FL140)

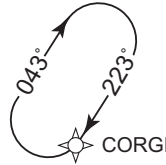

1MIN(at or below FL140)
1.5MIN(above FL140)

MHA 5000 NOT TO SCALE
MAX 230KIAS(at or below FL140)
MAX 240KIAS(above FL140)

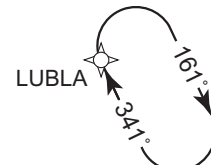

1MIN(at or below FL140)
1.5MIN(above FL140)

LUBLA E ARRIVAL

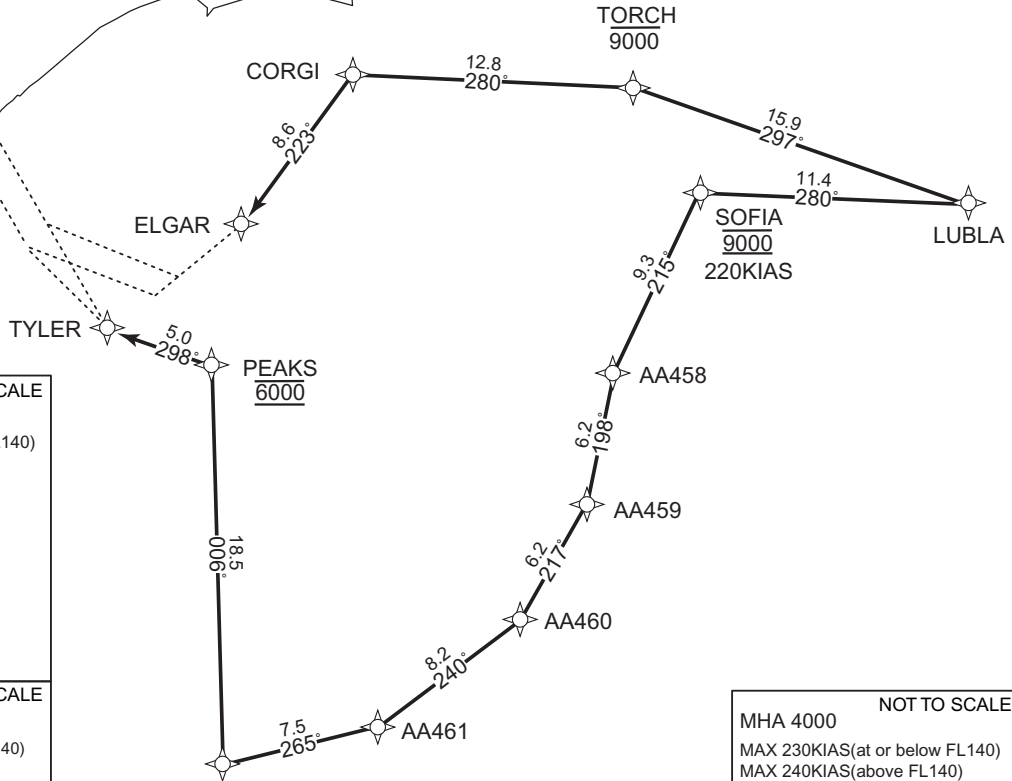

LUBLA T ARRIVAL

NOT TO SCALE
MHA 3000
MAX 230KIAS(at or below FL140)
MAX 240KIAS(above FL140)



1MIN(at or below FL140)
1.5MIN(above FL140)

NOT TO SCALE

MHA 3000
MAX 230KIAS(at or below FL140)
MAX 240KIAS(above FL140)

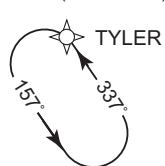

1MIN(at or below FL140)
1.5MIN(above FL140)

NOT TO SCALE
MHA 4000
MAX 230KIAS(at or below FL140)
MAX 240KIAS(above FL140)

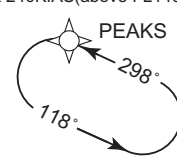

1MIN(at or below FL140)
1.5MIN(above FL140)

CHANGE : Description of HLDG pattern.

STANDARD ARRIVAL CHART - INSTRUMENT

RJAA / NARITA INTL

RNAV STAR RWY34L/34R

LUBLA E ARRIVAL

From LUBLA, to TORCH at or below 9000FT, to CORGI, to ELGAR.

Critical DME	-
DME GAP	-
Inappropriate Nav aids	See AD1.1.6.10.3. Inappropriate NAVAIDs for RNAV1

Serial Number	Path Descriptor	Waypoint Identifier	Fly Over	Course °M(°T)	Magnetic Variation	Distance (NM)	Turn Direction	Altitude (FT)	Speed (KIAS)	Vertical Angle	Navigation Specification
001	IF	LUBLA	-	-	-7.5	-	-	-	-	-	RNAV1
002	TF	TORCH	-	297 (289.5)	-7.5	15.9	-	-9000	-	-	RNAV1
003	TF	CORGI	-	280 (272.8)	-7.5	12.8	-	-	-	-	RNAV1
004	TF	ELGAR	-	223 (215.7)	-7.5	8.6	-	-	-	-	RNAV1

Path	Waypoint Identifier	Inbound Course °M(°T)	Magnetic Variation	Outbound Time (MIN)	Outbound Distance (NM)	Turn Direction	Minimum Altitude (FT)	Maximum Altitude (FT)	Speed (KIAS)	Navigation Specification
Hold	LUBLA	341 (333.9)	-7.5	1.0(-14000) 1.5(+14001)	-	R	5000	-	-230(-14000) -240(+14001)	RNAV1
Hold	CORGI	223 (215.8)	-7.5	1.0(-14000) 1.5(+14001)	-	R	4000	-	-230(-14000) -240(+14001)	RNAV1
Hold	ELGAR	223 (215.7)	-7.5	1.0(-14000) 1.5(+14001)	-	R	3000	-	-230(-14000) -240(+14001)	RNAV1

CHANGE : New PROC

STANDARD ARRIVAL CHART - INSTRUMENT

RJAA / NARITA INTL

RNAV STAR RWY34L/34R

LUBLA T ARRIVAL

From LUBLA, to SOFIA at 9000FT, to AA458, to AA459, to AA460, to AA461, to BELKS at 9000FT, to PEAKS at 6000FT, to TYLER.

Critical DME	-
DME GAP	-
Inappropriate Nav aids	See AD1.1.6.10.3. Inappropriate NAVAIDs for RNAV1

Serial Number	Path Descriptor	Waypoint Identifier	Fly Over	Course °M(°T)	Magnetic Variation	Distance (NM)	Turn Direction	Altitude (FT)	Speed (KIAS)	Vertical Angle	Navigation Specification
001	IF	LUBLA	-	-	-7.5	-	-	-	-	-	RNAV1
002	TF	SOFIA	-	280 (272.2)	-7.5	11.4	-	9000	220	-	RNAV1
003	TF	AA458	-	215 (207.2)	-7.5	9.3	-	-	-	-	RNAV1
004	TF	AA459	-	198 (190.7)	-7.5	6.2	-	-	-	-	RNAV1
005	TF	AA460	-	217 (209.8)	-7.5	6.2	-	-	-	-	RNAV1
006	TF	AA461	-	240 (232.2)	-7.5	8.2	-	-	-	-	RNAV1
007	TF	BELKS	-	265 (257.8)	-7.5	7.5	-	9000	220	-	RNAV1
008	TF	PEAKS	-	006 (358.3)	-7.5	18.5	-	6000	-	-	RNAV1
009	TF	TYLER	-	298 (290.2)	-7.5	5.0	-	-	-	-	RNAV1

Path	Waypoint Identifier	Inbound Course °M(°T)	Magnetic Variation	Outbound Time (MIN)	Outbound Distance (NM)	Turn Direction	Minimum Altitude (FT)	Maximum Altitude (FT)	Speed (KIAS)	Navigation Specification
Hold	LUBLA	341 (333.9)	-7.5	1.0(-14000) 1.5(+14001)	-	R	5000	-	-230(-14000) -240(+14001)	RNAV1
Hold	PEAKS	298 (290.2)	-7.5	1.0(-14000) 1.5(+14001)	-	L	4000	-	-230(-14000) -240(+14001)	RNAV1
Hold	TYLER	337 (329.8)	-7.5	1.0(-14000) 1.5(+14001)	-	L	3000	-	-230(-14000) -240(+14001)	RNAV1

Waypoint Coordinates

Waypoint Identifier	Coordinates	Waypoint Identifier	Coordinates
AA458	352446.9N / 1410638.5E	ELGAR	353129.2N / 1404527.4E
AA459	351840.7N / 1410513.6E	LUBLA	353235.0N / 1412550.8E
AA460	351317.5N / 1410127.0E	PEAKS	352507.2N / 1404352.7E
AA461	350814.0N / 1405329.6E	SOFIA	353300.1N / 1411149.9E
BELKS	350638.5N / 1404433.3E	TORCH	353752.8N / 1410721.7E
CORGI	353829.8N / 1405138.9E	TYLER	352650.5N / 1403807.8E

CHANGE : HLDG Pattern (PEAKS) established

STANDARD ARRIVAL CHART - INSTRUMENT

RJAA / NARITA INTL

RNAV STAR RWY16R/16L

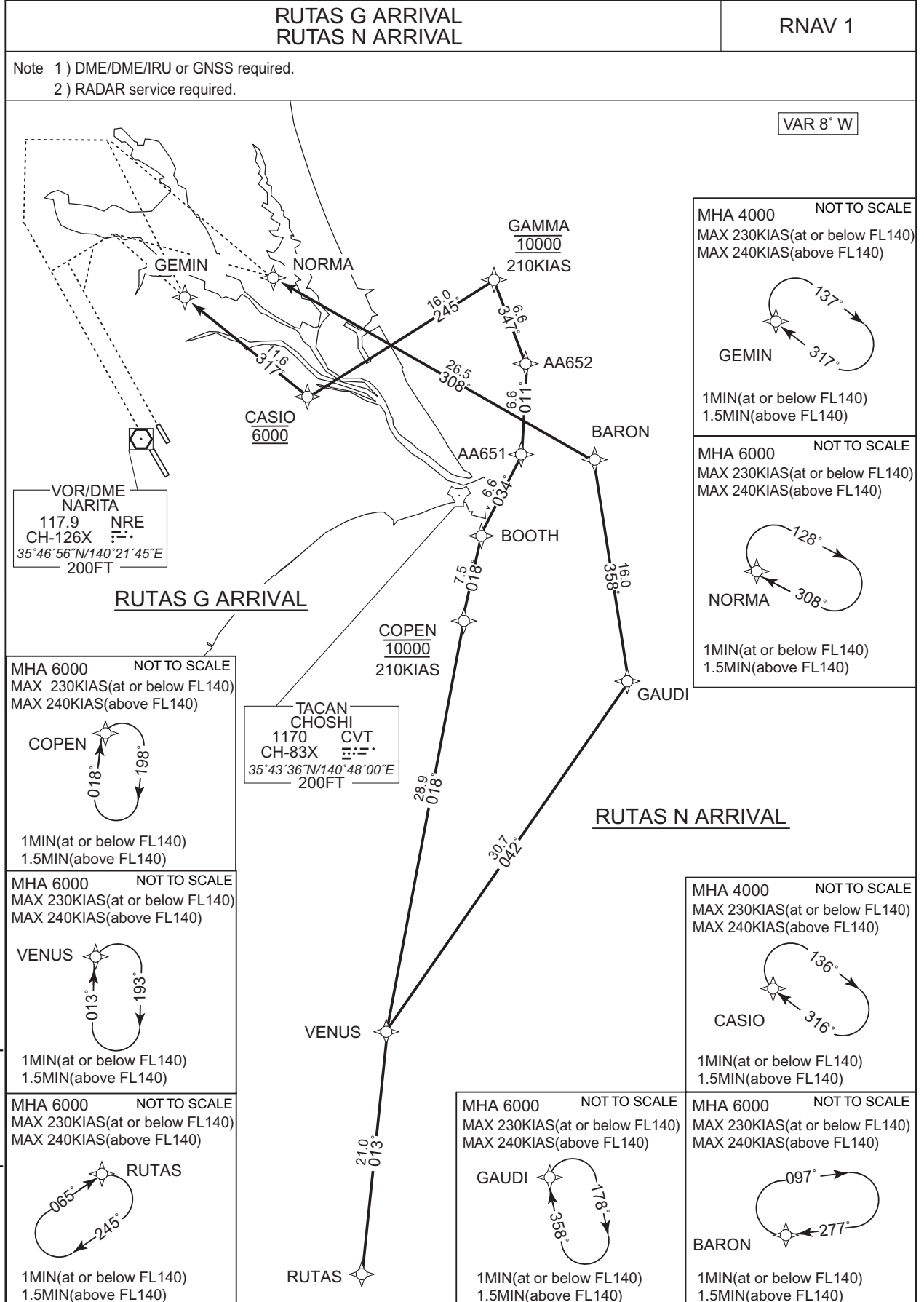

CHANGE : Description of HLDG pattern.

STANDARD ARRIVAL CHART - INSTRUMENT

RJAA / NARITA INTL

RNAV STAR RWY16R/16L

RUTAS G ARRIVAL

From RUTAS, to VENUS, to COPEN at 10000FT, to BOOTH, to AA651, to AA652, to GAMMA at 10000FT, to CASIO at 6000FT, to GEMIN.

Critical DME	-
DME GAP	-
Inappropriate Nav aids	See AD1.1.6.10.3. Inappropriate NAVAIDs for RNAV1

Serial Number	Path Descriptor	Waypoint Identifier	Fly Over	Course °M(°T)	Magnetic Variation	Distance (NM)	Turn Direction	Altitude (FT)	Speed (KIAS)	Vertical Angle	Navigation Specification
001	IF	RUTAS	-	-	-7.5	-	-	-	-	-	RNAV1
002	TF	VENUS	-	013 (005.8)	-7.5	21.0	-	-	-	-	RNAV1
003	TF	COPEN	-	018 (010.5)	-7.5	28.9	-	10000	210	-	RNAV1
004	TF	BOOTH	-	018 (010.6)	-7.5	7.5	-	-	-	-	RNAV1
005	TF	AA651	-	034 (026.6)	-7.5	6.6	-	-	-	-	RNAV1
006	TF	AA652	-	011 (003.1)	-7.5	6.6	-	-	-	-	RNAV1
007	TF	GAMMA	-	347 (339.6)	-7.5	6.6	-	10000	210	-	RNAV1
008	TF	CASIO	-	245 (237.6)	-7.5	16.0	-	6000	-	-	RNAV1
009	TF	GEMIN	-	317 (309.1)	-7.5	11.6	-	-	-	-	RNAV1

Path	Waypoint Identifier	Inbound Course °M(°T)	Magnetic Variation	Outbound Time (MIN)	Outbound Distance (NM)	Turn Direction	Minimum Altitude (FT)	Maximum Altitude (FT)	Speed (KIAS)	Navigation Specification
Hold	RUTAS	065 (057.9)	-7.5	1.0(-14000) 1.5(+14001)	-	R	6000	-	-230(-14000) -240(+14001)	RNAV1
Hold	VENUS	013 (005.8)	-7.5	1.0(-14000) 1.5(+14001)	-	R	6000	-	-230(-14000) -240(+14001)	RNAV1
Hold	COPEN	018 (010.5)	-7.5	1.0(-14000) 1.5(+14001)	-	R	6000	-	-230(-14000) -240(+14001)	RNAV1
Hold	CASIO	316 (308.6)	-7.5	1.0(-14000) 1.5(+14001)	-	R	4000	-	-230(-14000) -240(+14001)	RNAV1
Hold	GEMIN	317 (309.1)	-7.5	1.0(-14000) 1.5(+14001)	-	R	4000	-	-230(-14000) -240(+14001)	RNAV1

CHANGE : BOOTH renamed

STANDARD ARRIVAL CHART - INSTRUMENT

RJAA / NARITA INTL

RNAV STAR RWY16R/16L

RUTAS N ARRIVAL

From RUTAS, to VENUS, to GAUDI, to BARON, to NORMA.

Critical DME	-
DME GAP	-
Inappropriate Navaids	See AD1.1.6.10.3. Inappropriate NAVAIDs for RNAV1

Serial Number	Path Descriptor	Waypoint Identifier	Fly Over	Course °M(°T)	Magnetic Variation	Distance (NM)	Turn Direction	Altitude (FT)	Speed (KIAS)	Vertical Angle	Navigation Specification
001	IF	RUTAS	-	-	-7.5	-	-	-	-	-	RNAV1
002	TF	VENUS	-	013 (005.8)	-7.5	21.0	-	-	-	-	RNAV1
003	TF	GAUDI	-	042 (034.1)	-7.5	30.7	-	-	-	-	RNAV1
004	TF	BARON	-	358 (351.0)	-7.5	16.0	-	-	-	-	RNAV1
005	TF	NORMA	-	308 (300.0)	-7.5	26.5	-	-	-	-	RNAV1

Path	Waypoint Identifier	Inbound Course °M(°T)	Magnetic Variation	Outbound Time (MIN)	Outbound Distance (NM)	Turn Direction	Minimum Altitude (FT)	Maximum Altitude (FT)	Speed (KIAS)	Navigation Specification
Hold	RUTAS	065 (057.9)	-7.5	1.0(-14000) 1.5(+14001)	-	R	6000	-	-230(-14000) -240(+14001)	RNAV1
Hold	VENUS	013 (005.8)	-7.5	1.0(-14000) 1.5(+14001)	-	R	6000	-	-230(-14000) -240(+14001)	RNAV1
Hold	GAUDI	358 (351.0)	-7.5	1.0(-14000) 1.5(+14001)	-	R	6000	-	-230(-14000) -240(+14001)	RNAV1
Hold	BARON	277 (270.0)	-7.5	1.0(-14000) 1.5(+14001)	-	R	6000	-	-230(-14000) -240(+14001)	RNAV1
Hold	NORMA	308 (300.0)	-7.5	1.0(-14000) 1.5(+14001)	-	R	6000	-	-230(-14000) -240(+14001)	RNAV1

Waypoint Coordinates

Waypoint Identifier	Coordinates	Waypoint Identifier	Coordinates
AA651	354615.0N / 1405457.4E	GAMMA	355856.3N / 1405234.6E
AA652	355247.8N / 1405523.8E	GAUDI	353002.4N / 1410418.1E
BARON	354551.0N / 1410112.0E	GEMIN	355738.6N / 1402450.7E
BOOTH	354023.6N / 1405120.5E	NORMA	355900.8N / 1403254.0E
CASIO	355021.4N / 1403556.1E	RUTAS	344349.3N / 1404034.2E
COPEN	353303.7N / 1404939.2E	VENUS	350440.1N / 1404309.7E

CHANGE : BOOTH renamed

STANDARD ARRIVAL CHART - INSTRUMENT

RJAA / NARITA INTL

RNAV STAR RWY16R/16L

SWAMP G ARRIVAL
SWAMP N ARRIVAL

RNAV 1

Note 1) DME/DME/IRU or GNSS required.
2) RADAR service required.

NOT TO SCALE

MHA 11000
MAX 230KIAS(at or below FL140)
MAX 240KIAS(above FL140)

SWAMP

1MIN(at or below FL140)
1.5MIN(above FL140)

VAR 8° W

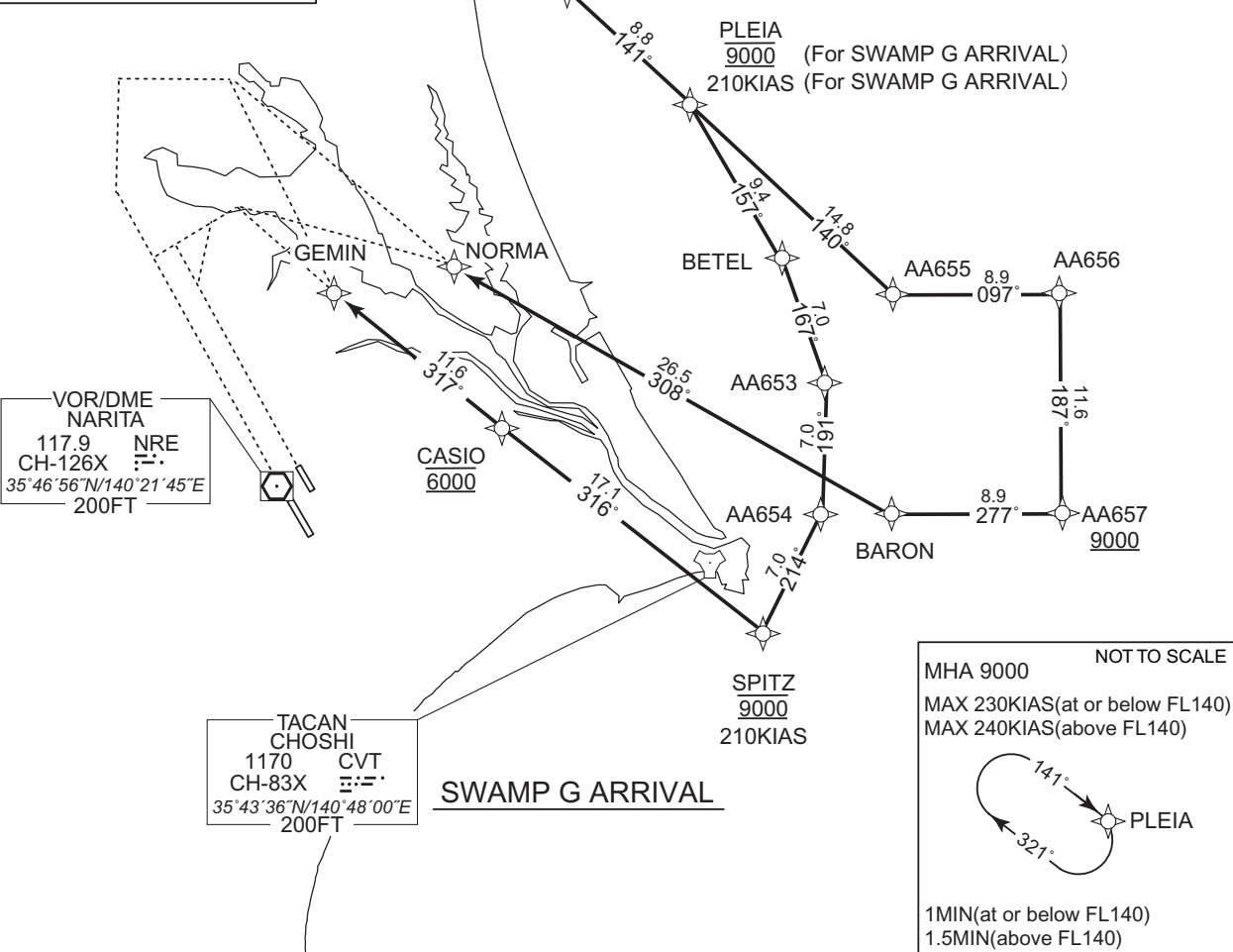

NOT TO SCALE

MHA 9000
MAX 230KIAS(at or below FL140)
MAX 240KIAS(above FL140)

PLEIA

1MIN(at or below FL140)
1.5MIN(above FL140)

CHANGE : Description of HLDG pattern.

NOT TO SCALE

MHA 4000
MAX 230KIAS(at or below FL140)
MAX 240KIAS(above FL140)

GEMIN

1MIN(at or below FL140)
1.5MIN(above FL140)

NOT TO SCALE

MHA 6000
MAX 230KIAS(at or below FL140)
MAX 240KIAS(above FL140)

NORMA

1MIN(at or below FL140)
1.5MIN(above FL140)

NOT TO SCALE

MHA 4000
MAX 230KIAS(at or below FL140)
MAX 240KIAS(above FL140)

CASIO

1MIN(at or below FL140)
1.5MIN(above FL140)

NOT TO SCALE

MHA 6000
MAX 230KIAS(at or below FL140)
MAX 240KIAS(above FL140)

BARON

1MIN(at or below FL140)
1.5MIN(above FL140)

STANDARD ARRIVAL CHART - INSTRUMENT

RJAA / NARITA INTL

RNAV STAR RWY16R/16L

SWAMP G ARRIVAL

From SWAMP, to VIXEN at or above 11000FT, to PLEIA at 9000FT, to BETEL, to AA653, to AA654, to SPITZ at 9000FT, to CASIO at 6000FT, to GEMIN.

Critical DME	-
DME GAP	-
Inappropriate Nav aids	See AD1.1.6.10.3. Inappropriate NAVAIDs for RNAV1

Serial Number	Path Descriptor	Waypoint Identifier	Fly Over	Course °M(°T)	Magnetic Variation	Distance (NM)	Turn Direction	Altitude (FT)	Speed (KIAS)	Vertical Angle	Navigation Specification
001	IF	SWAMP	-	-	-7.5	-	-	-	-	-	RNAV1
002	TF	VIXEN	-	140 (133.0)	-7.5	8.3	-	+11000	-	-	RNAV1
003	TF	PLEIA	-	141 (133.0)	-7.5	8.8	-	9000	210	-	RNAV1
004	TF	BETEL	-	157 (149.1)	-7.5	9.4	-	-	-	-	RNAV1
005	TF	AA653	-	167 (159.6)	-7.5	7.0	-	-	-	-	RNAV1
006	TF	AA654	-	191 (183.1)	-7.5	7.0	-	-	-	-	RNAV1
007	TF	SPITZ	-	214 (206.6)	-7.5	7.0	-	9000	210	-	RNAV1
008	TF	CASIO	-	316 (308.6)	-7.5	17.1	-	6000	-	-	RNAV1
009	TF	GEMIN	-	317 (309.1)	-7.5	11.6	-	-	-	-	RNAV1

Path	Waypoint Identifier	Inbound Course °M(°T)	Magnetic Variation	Outbound Time (MIN)	Outbound Distance (NM)	Turn Direction	Minimum Altitude (FT)	Maximum Altitude (FT)	Speed (KIAS)	Navigation Specification
Hold	SWAMP	205 (197.0)	-7.5	1.0(-14000) 1.5(+14001)	-	L	11000	-	-230(-14000) -240(+14001)	RNAV1
Hold	PLEIA	141 (133.1)	-7.5	1.0(-14000) 1.5(+14001)	-	R	9000	-	-230(-14000) -240(+14001)	RNAV1
Hold	CASIO	316 (308.6)	-7.5	1.0(-14000) 1.5(+14001)	-	R	4000	-	-230(-14000) -240(+14001)	RNAV1
Hold	GEMIN	317 (309.1)	-7.5	1.0(-14000) 1.5(+14001)	-	R	4000	-	-230(-14000) -240(+14001)	RNAV1

CHANGE : New PROC

STANDARD ARRIVAL CHART - INSTRUMENT

RJAA / NARITA INTL

RNAV STAR RWY16R/16L

SWAMP N ARRIVAL

From SWAMP, to VIXEN at or above 11000FT, to PLEIA, to AA655, to AA656, to AA657 at or above 9000FT, to BARON, to NORMA.

Critical DME	-
DME GAP	-
Inappropriate Nav aids	See AD1.1.6.10.3. Inappropriate NAVAIDs for RNAV1

Serial Number	Path Descriptor	Waypoint Identifier	Fly Over	Course °M(°T)	Magnetic Variation	Distance (NM)	Turn Direction	Altitude (FT)	Speed (KIAS)	Vertical Angle	Navigation Specification
001	IF	SWAMP	-	-	-7.5	-	-	-	-	-	RNAV1
002	TF	VIXEN	-	140 (133.0)	-7.5	8.3	-	+11000	-	-	RNAV1
003	TF	PLEIA	-	141 (133.0)	-7.5	8.8	-	-	-	-	RNAV1
004	TF	AA655	-	140 (132.9)	-7.5	14.8	-	-	-	-	RNAV1
005	TF	AA656	-	097 (089.9)	-7.5	8.9	-	-	-	-	RNAV1
006	TF	AA657	-	187 (180.0)	-7.5	11.6	-	+9000	-	-	RNAV1
007	TF	BARON	-	277 (270.0)	-7.5	8.9	-	-	-	-	RNAV1
008	TF	NORMA	-	308 (300.0)	-7.5	26.5	-	-	-	-	RNAV1

Path	Waypoint Identifier	Inbound Course °M(°T)	Magnetic Variation	Outbound Time (MIN)	Outbound Distance (NM)	Turn Direction	Minimum Altitude (FT)	Maximum Altitude (FT)	Speed (KIAS)	Navigation Specification
Hold	SWAMP	205 (197.0)	-7.5	1.0(-14000) 1.5(+14001)	-	L	11000	-	-230(-14000) -240(+14001)	RNAV1
Hold	PLEIA	141 (133.1)	-7.5	1.0(-14000) 1.5(+14001)	-	R	9000	-	-230(-14000) -240(+14001)	RNAV1
Hold	BARON	277 (270.0)	-7.5	1.0(-14000) 1.5(+14001)	-	R	6000	-	-230(-14000) -240(+14001)	RNAV1
Hold	NORMA	308 (300.0)	-7.5	1.0(-14000) 1.5(+14001)	-	R	6000	-	-230(-14000) -240(+14001)	RNAV1

Waypoint Coordinates

Waypoint Identifier	Coordinates	Waypoint Identifier	Coordinates
AA653	355257.7N / 1405644.1E	CASIO	355021.4N / 1403556.1E
AA654	354557.9N / 1405615.8E	GEMIN	355738.6N / 1402450.7E
AA655	355728.9N / 1410110.3E	NORMA	355900.8N / 1403254.0E
AA656	355729.4N / 1411209.0E	PLEIA	360734.8N / 1404745.4E
AA657	354551.6N / 1411209.1E	SPITZ	353942.4N / 1405223.9E
BARON	354551.0N / 1410112.0E	SWAMP	361914.4N / 1403217.0E
BETEL	355931.6N / 1405343.4E	VIXEN	361335.9N / 1403947.1E

CHANGE : ALT Restriction on AA655, AA657

STANDARD ARRIVAL CHART - INSTRUMENT

RJAA / NARITA INTL

RNAV STAR RWY16R/16L

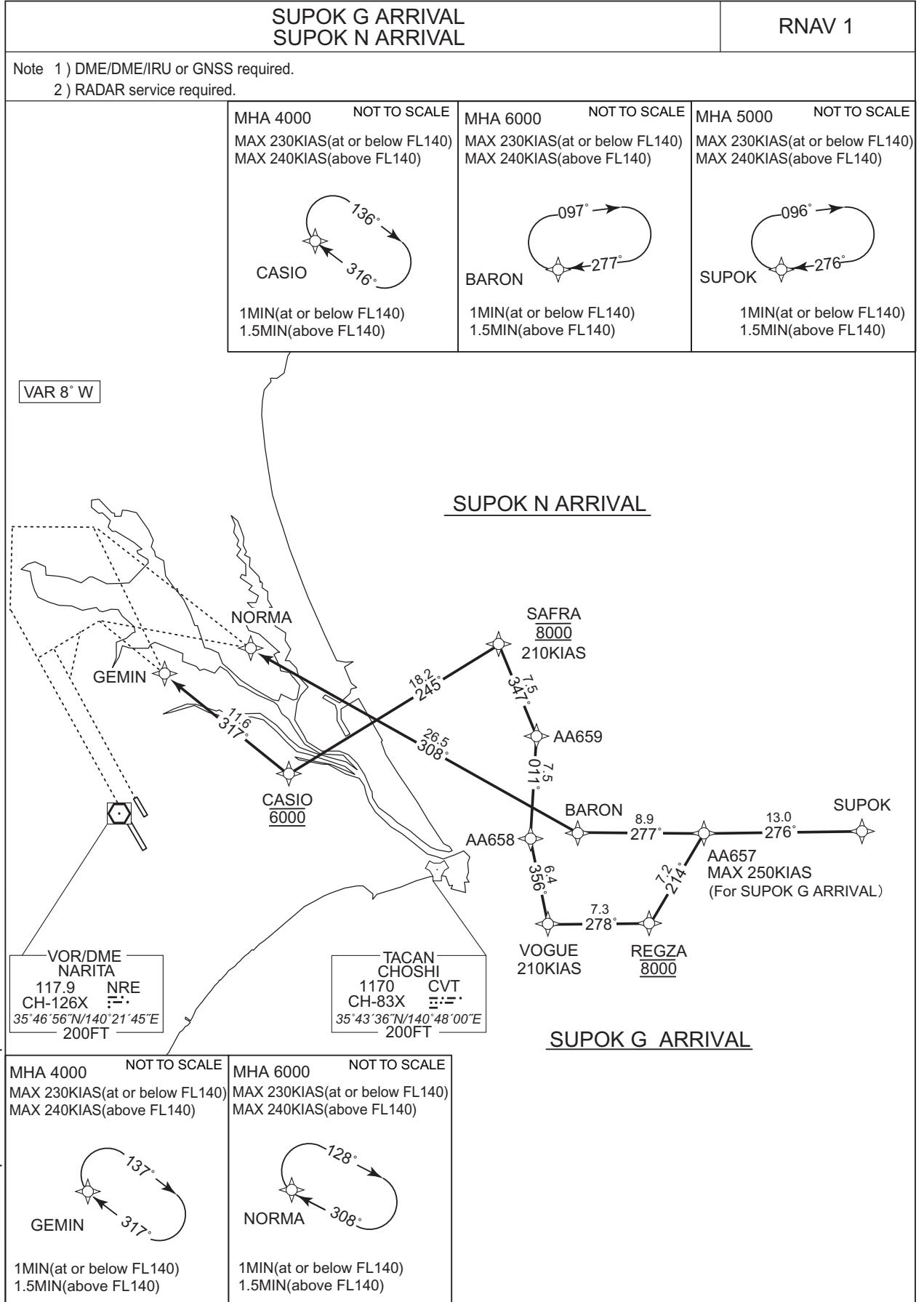

STANDARD ARRIVAL CHART - INSTRUMENT

RJAA / NARITA INTL

RNAV STAR RWY16R/16L

SUPOK G ARRIVAL

From SUPOK, to AA657, to REGZA at 8000FT, to VOGUE, to AA658, to AA659, to SAFRA at 8000FT, to CASIO at 6000FT, to GEMIN.

Critical DME	-
DME GAP	-
Inappropriate Navaids	See AD1.1.6.10.3. Inappropriate NAVAIDs for RNAV1

Serial Number	Path Descriptor	Waypoint Identifier	Fly Over	Course °M(°T)	Magnetic Variation	Distance (NM)	Turn Direction	Altitude (FT)	Speed (KIAS)	Vertical Angle	Navigation Specification
001	IF	SUPOK	-	-	-7.5	-	-	-	-	-	RNAV1
002	TF	AA657	-	276 (268.4)	-7.5	13.0	-	-	-250	-	RNAV1
003	TF	REGZA	-	214 (206.8)	-7.5	7.2	-	8000	-	-	RNAV1
004	TF	VOGUE	-	278 (270.3)	-7.5	7.3	-	-	210	-	RNAV1
005	TF	AA658	-	356 (348.4)	-7.5	6.4	-	-	-	-	RNAV1
006	TF	AA659	-	011 (003.1)	-7.5	7.5	-	-	-	-	RNAV1
007	TF	SAFRA	-	347 (339.6)	-7.5	7.5	-	8000	210	-	RNAV1
008	TF	CASIO	-	245 (237.6)	-7.5	18.2	-	6000	-	-	RNAV1
009	TF	GEMIN	-	317 (309.1)	-7.5	11.6	-	-	-	-	RNAV1

Path	Waypoint Identifier	Inbound Course °M(°T)	Magnetic Variation	Outbound Time (MIN)	Outbound Distance (NM)	Turn Direction	Minimum Altitude (FT)	Maximum Altitude (FT)	Speed (KIAS)	Navigation Specification
Hold	SUPOK	276 (268.6)	-7.5	1.0(-14000) 1.5(+14001)	-	R	5000	-	-230(-14000) -240(+14001)	RNAV1
Hold	CASIO	316 (308.6)	-7.5	1.0(-14000) 1.5(+14001)	-	R	4000	-	-230(-14000) -240(+14001)	RNAV1
Hold	GEMIN	317 (309.1)	-7.5	1.0(-14000) 1.5(+14001)	-	R	4000	-	-230(-14000) -240(+14001)	RNAV1

CHANGE : New PROC

STANDARD ARRIVAL CHART - INSTRUMENT

RJAA / NARITA INTL

RNAV STAR RWY16R/16L

SUPOK N ARRIVAL

From SUPOK, to AA657, to BARON, to NORMA.

Critical DME	-
DME GAP	-
Inappropriate Nav aids	See AD1.1.6.10.3. Inappropriate NAVAIDs for RNAV1

Serial Number	Path Descriptor	Waypoint Identifier	Fly Over	Course °M(°T)	Magnetic Variation	Distance (NM)	Turn Direction	Altitude (FT)	Speed (KIAS)	Vertical Angle	Navigation Specification
001	IF	SUPOK	-	-	-7.5	-	-	-	-	-	RNAV1
002	TF	AA657	-	276 (268.4)	-7.5	13.0	-	-	-	-	RNAV1
003	TF	BARON	-	277 (270.0)	-7.5	8.9	-	-	-	-	RNAV1
004	TF	NORMA	-	308 (300.0)	-7.5	26.5	-	-	-	-	RNAV1

Path	Waypoint Identifier	Inbound Course °M(°T)	Magnetic Variation	Outbound Time (MIN)	Outbound Distance (NM)	Turn Direction	Minimum Altitude (FT)	Maximum Altitude (FT)	Speed (KIAS)	Navigation Specification
Hold	SUPOK	276 (268.6)	-7.5	1.0(-14000) 1.5(+14001)	-	R	5000	-	-230(-14000) -240(+14001)	RNAV1
Hold	BARON	277 (270.0)	-7.5	1.0(-14000) 1.5(+14001)	-	R	6000	-	-230(-14000) -240(+14001)	RNAV1
Hold	NORMA	308 (300.0)	-7.5	1.0(-14000) 1.5(+14001)	-	R	6000	-	-230(-14000) -240(+14001)	RNAV1

Waypoint Coordinates

Waypoint Identifier	Coordinates	Waypoint Identifier	Coordinates
AA657	354551.6N / 1411209.1E	NORMA	355900.8N / 1403254.0E
AA658	354540.9N / 1405734.1E	REGZA	353925.8N / 1410809.1E
AA659	355307.6N / 1405804.5E	SAFRA	360006.9N / 1405452.2E
BARON	354551.0N / 1410112.0E	SUPOK	354614.1N / 1412810.0E
CASIO	355021.4N / 1403556.1E	VOGUE	353927.6N / 1405908.4E
GEMIN	355738.6N / 1402450.7E		

CHANGE : New PROC

STANDARD ARRIVAL CHART - INSTRUMENT

RJAA / NARITA INTL

RNAV STAR RWY16R/16L

LUBLA G ARRIVAL
LUBLA N ARRIVAL

RNAV 1

Note 1) DME/DME/IRU or GNSS required.
2) RADAR service required.

MHA 4000 NOT TO SCALE
MAX 230KIAS(at or below FL140)
MAX 240KIAS(above FL140)

CASIO

1MIN(at or below FL140)
1.5MIN(above FL140)

MHA 6000 NOT TO SCALE
MAX 230KIAS(at or below FL140)
MAX 240KIAS(above FL140)

BARON

1MIN(at or below FL140)
1.5MIN(above FL140)

MHA 5000 NOT TO SCALE
MAX 230KIAS(at or below FL140)
MAX 240KIAS(above FL140)

LUBLA

1MIN(at or below FL140)
1.5MIN(above FL140)

VAR 8° W

MHA 4000 NOT TO SCALE
MAX 230KIAS(at or below FL140)
MAX 240KIAS(above FL140)

GEMIN

1MIN(at or below FL140)
1.5MIN(above FL140)

MHA 6000 NOT TO SCALE
MAX 230KIAS(at or below FL140)
MAX 240KIAS(above FL140)

NORMA

1MIN(at or below FL140)
1.5MIN(above FL140)

LUBLA N ARRIVAL

LUBLA G ARRIVAL

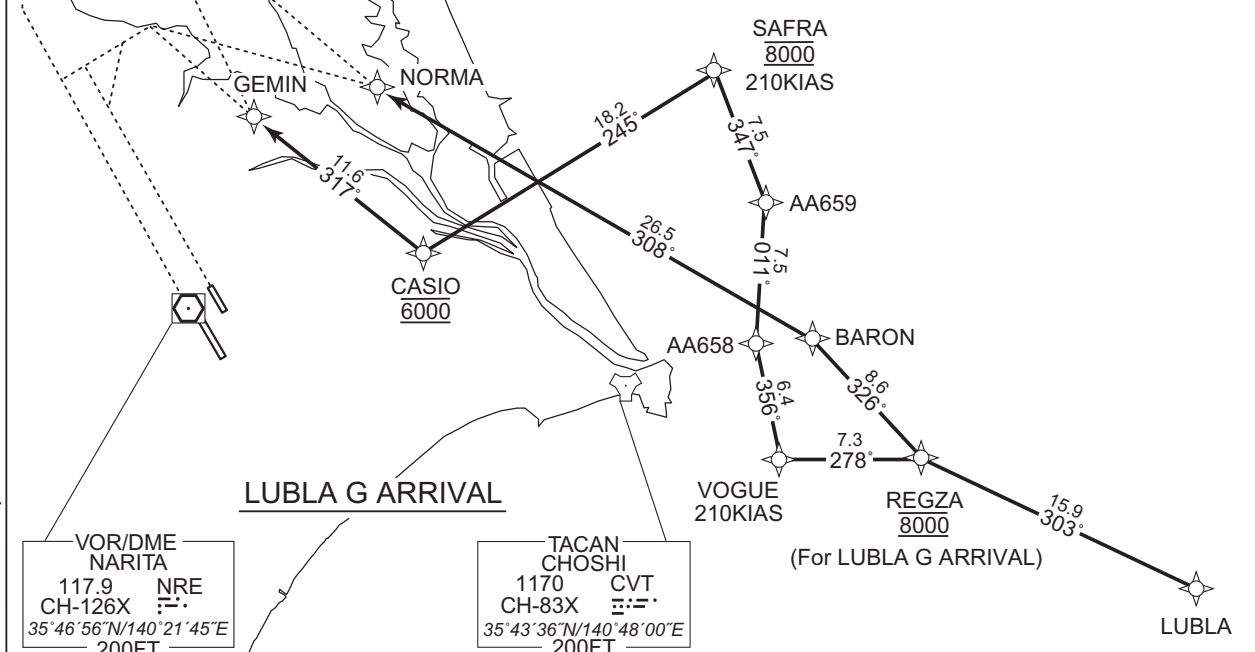

VOR/DME
NARITA
117.9 NRE
CH-126X
35°46'56"N/140°21'45"E
200FT

TACAN
CHOSHI
1170 CVT
CH-83X
35°43'36"N/140°48'00"E
200FT

CHANGE : Description of HLDG pattern.

STANDARD ARRIVAL CHART - INSTRUMENT

RJAA / NARITA INTL

RNAV STAR RWY16R/16L

LUBLA G ARRIVAL

From LUBLA, to REGZA at 8000FT, to VOGUE, to AA658, to AA659, to SAFRA at 8000FT, to CASIO at 6000FT, to GEMIN.

Critical DME	-
DME GAP	-
Inappropriate Nav aids	See AD1.1.6.10.3. Inappropriate NAVAIDs for RNAV1

Serial Number	Path Descriptor	Waypoint Identifier	Fly Over	Course °M(°T)	Magnetic Variation	Distance (NM)	Turn Direction	Altitude (FT)	Speed (KIAS)	Vertical Angle	Navigation Specification
001	IF	LUBLA	-	-	-7.5	-	-	-	-	-	RNAV1
002	TF	REGZA	-	303 (295.5)	-7.5	15.9	-	8000	-	-	RNAV1
003	TF	VOGUE	-	278 (270.3)	-7.5	7.3	-	-	210	-	RNAV1
004	TF	AA658	-	356 (348.4)	-7.5	6.4	-	-	-	-	RNAV1
005	TF	AA659	-	011 (003.1)	-7.5	7.5	-	-	-	-	RNAV1
006	TF	SAFRA	-	347 (339.6)	-7.5	7.5	-	8000	210	-	RNAV1
007	TF	CASIO	-	245 (237.6)	-7.5	18.2	-	6000	-	-	RNAV1
008	TF	GEMIN	-	317 (309.1)	-7.5	11.6	-	-	-	-	RNAV1

Path	Waypoint Identifier	Inbound Course °M(°T)	Magnetic Variation	Outbound Time (MIN)	Outbound Distance (NM)	Turn Direction	Minimum Altitude (FT)	Maximum Altitude (FT)	Speed (KIAS)	Navigation Specification
Hold	LUBLA	341 (333.9)	-7.5	1.0(-14000) 1.5(+14001)	-	R	5000	-	-230(-14000) -240(+14001)	RNAV1
Hold	CASIO	316 (308.6)	-7.5	1.0(-14000) 1.5(+14001)	-	R	4000	-	-230(-14000) -240(+14001)	RNAV1
Hold	GEMIN	317 (309.1)	-7.5	1.0(-14000) 1.5(+14001)	-	R	4000	-	-230(-14000) -240(+14001)	RNAV1

CHANGE : New PROC

STANDARD ARRIVAL CHART - INSTRUMENT

RJAA / NARITA INTL

RNAV STAR RWY16R/16L

LUBLA N ARRIVAL

From LUBLA, to REGZA, to BARON, to NORMA.

Critical DME	-
DME GAP	-
Inappropriate Nav aids	See AD1.1.6.10.3. Inappropriate NAVAIDs for RNAV1

Serial Number	Path Descriptor	Waypoint Identifier	Fly Over	Course °M(°T)	Magnetic Variation	Distance (NM)	Turn Direction	Altitude (FT)	Speed (KIAS)	Vertical Angle	Navigation Specification
001	IF	LUBLA	-	-	-7.5	-	-	-	-	-	RNAV1
002	TF	REGZA	-	303 (295.5)	-7.5	15.9	-	-	-	-	RNAV1
003	TF	BARON	-	326 (318.7)	-7.5	8.6	-	-	-	-	RNAV1
004	TF	NORMA	-	308 (300.0)	-7.5	26.5	-	-	-	-	RNAV1

Path	Waypoint Identifier	Inbound Course °M(°T)	Magnetic Variation	Outbound Time (MIN)	Outbound Distance (NM)	Turn Direction	Minimum Altitude (FT)	Maximum Altitude (FT)	Speed (KIAS)	Navigation Specification
Hold	LUBLA	341 (333.9)	-7.5	1.0(-14000) 1.5(+14001)	-	R	5000	-	-230(-14000) -240(+14001)	RNAV1
Hold	BARON	277 (270.0)	-7.5	1.0(-14000) 1.5(+14001)	-	R	6000	-	-230(-14000) -240(+14001)	RNAV1
Hold	NORMA	308 (300.0)	-7.5	1.0(-14000) 1.5(+14001)	-	R	6000	-	-230(-14000) -240(+14001)	RNAV1

Waypoint Coordinates

Waypoint Identifier	Coordinates	Waypoint Identifier	Coordinates
AA658	354540.9N / 1405734.1E	LUBLA	353235.0N / 1412550.8E
AA659	355307.6N / 1405804.5E	NORMA	355900.8N / 1403254.0E
BARON	354551.0N / 1410112.0E	REGZA	353925.8N / 1410809.1E
CASIO	355021.4N / 1403556.1E	SAFRA	360006.9N / 1405452.2E
GEMIN	355738.6N / 1402450.7E	VOGUE	353927.6N / 1405908.4E

CHANGE : New PROC

INSTRUMENT APPROACH CHART

RJAA / NARITA INTL

ILS RWY34L

TOKYO APP 124.4 – 127.7 120.2 – 225.65	ILS – LOC 111.9 IYQ ILS – GP 331.1 ILS – DME CH-56X	NARITA TOWER 118.2–122.7–126.2 236.8–121.95G	RADAR AVBL ATIS 128.25
--	--	--	---------------------------

Simultaneous approach authorized with RWY34R

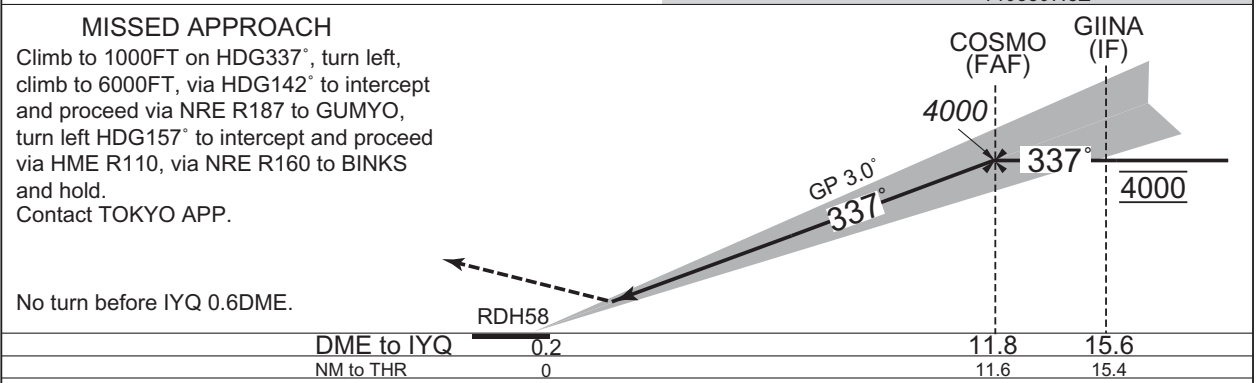
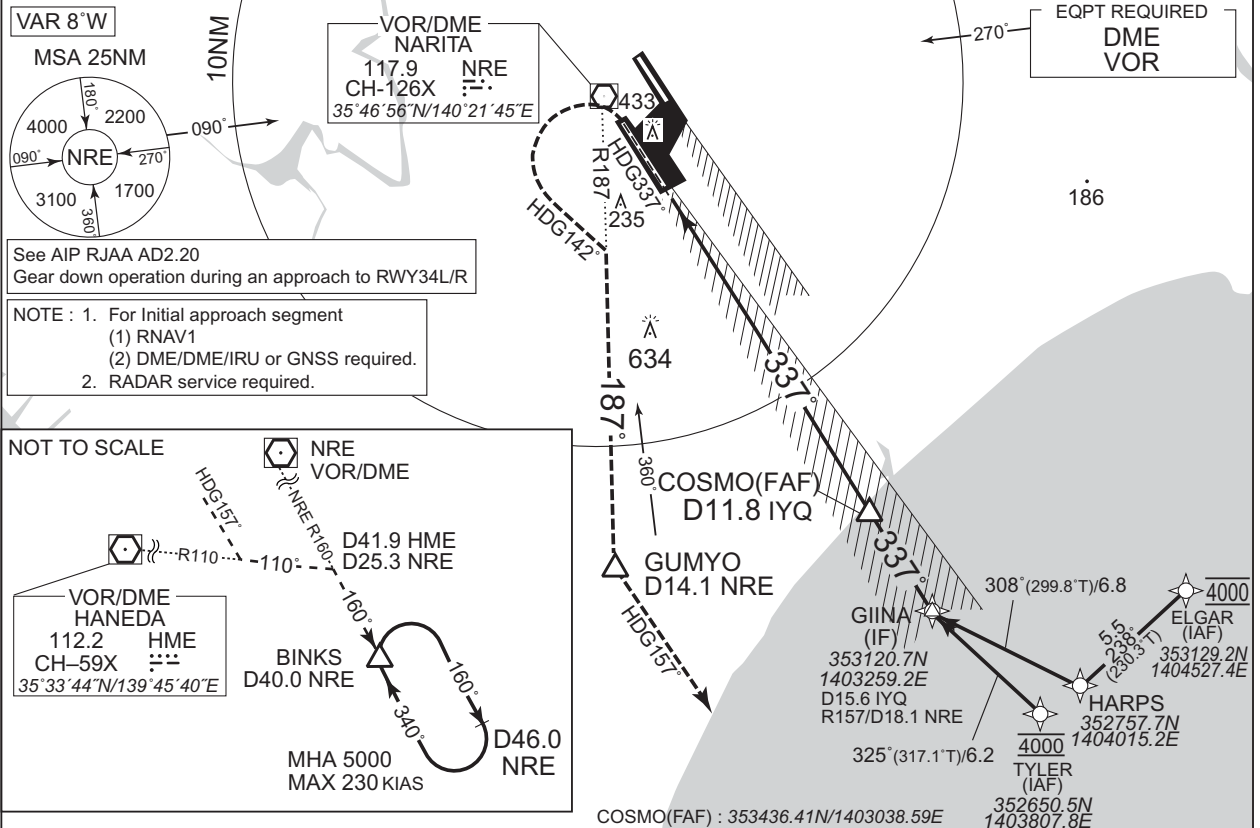

CHANGE : Description of HLDG pattern.

MINIMA	THR elev. 139	AD elev. 135		
CAT	CAT I		CIRCLING	
	DA(H)	RVR/CMV	MDA(H)	VIS
A	339 (200)	550	730 (595)	1600
B				2400
C				2400
D				3200

INSTRUMENT APPROACH CHART

RJAA / NARITA INTL

LOC RWY34L

TOKYO APP 124.4 – 127.7 120.2 – 225.65	ILS – LOC 111.9 IYQ $\equiv \equiv \equiv$ ILS – DME CH-56X	NARITA TOWER 118.2–122.7–126.2 236.8–121.95G	RADAR AVBL ATIS 128.25
--	---	--	---------------------------

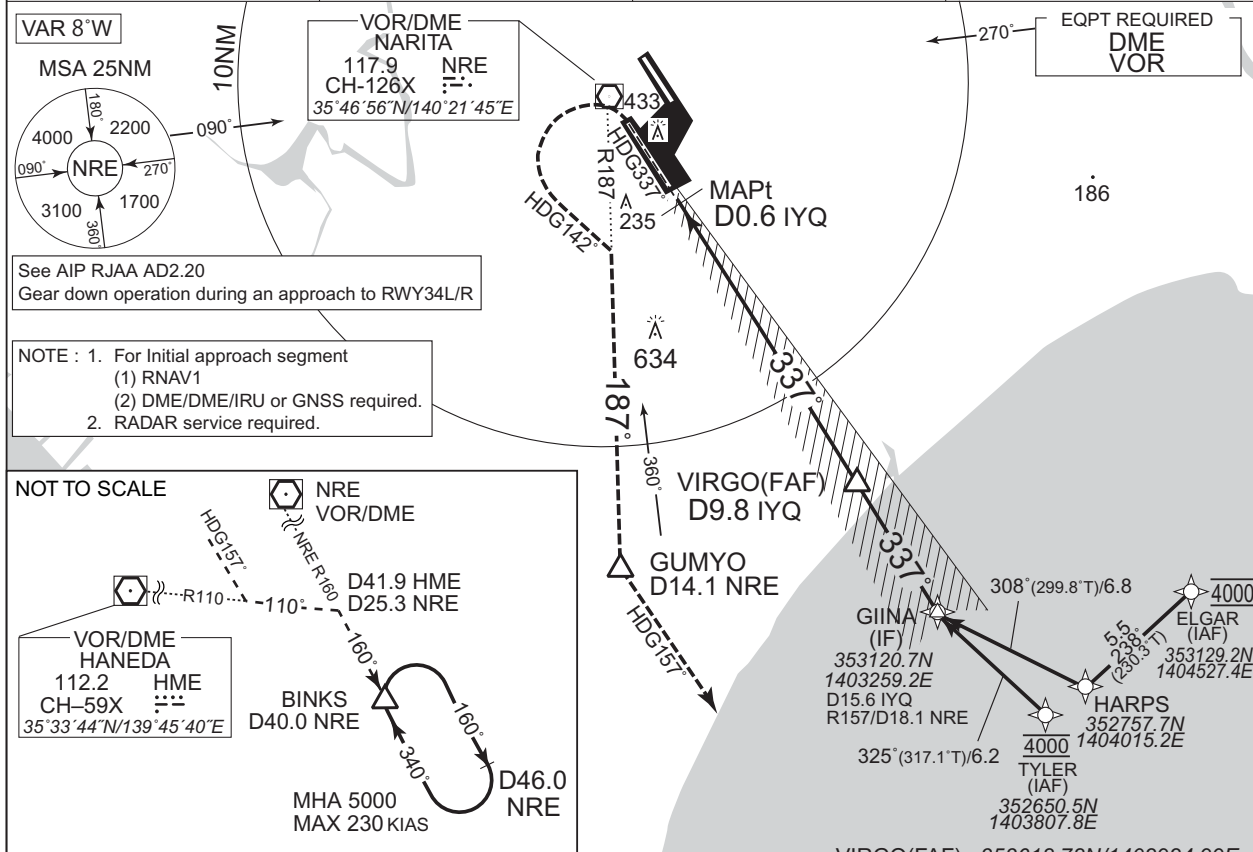

NM to IYQ	MAPt	2	3	4	5	6	7	8	9	FAF
ALT (3.0° APCH Path)	-	767	1086	1404	1723	2041	2359	2678	2996	3244

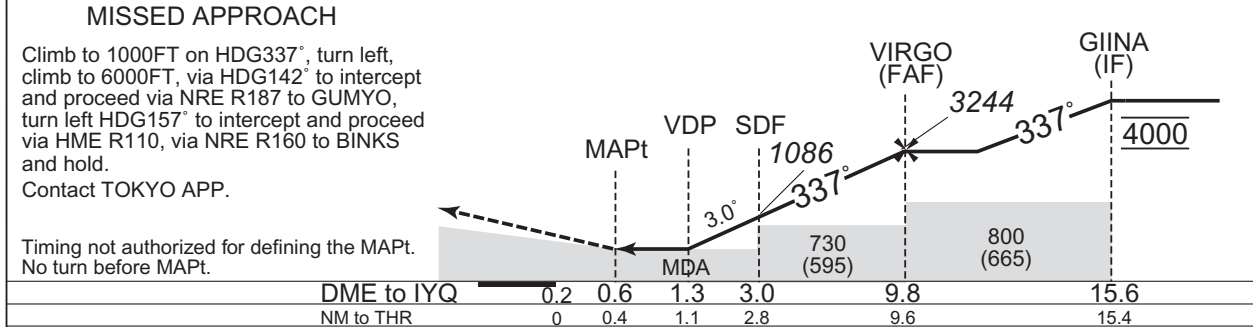

MINIMA		THR elev. 139	AD elev. 135	
CAT	MDA(H)		CIRCLING	
	RVR/CMV	MDA(H)	VIS	
A	530 (395)	900	730 (595)	1600
B		1000		2400
C		1400		3200
D				

CHANGE : Description of HLDG pattern.

INSTRUMENT APPROACH CHART

RJAA / NARITA INTL

VOR RWY34L

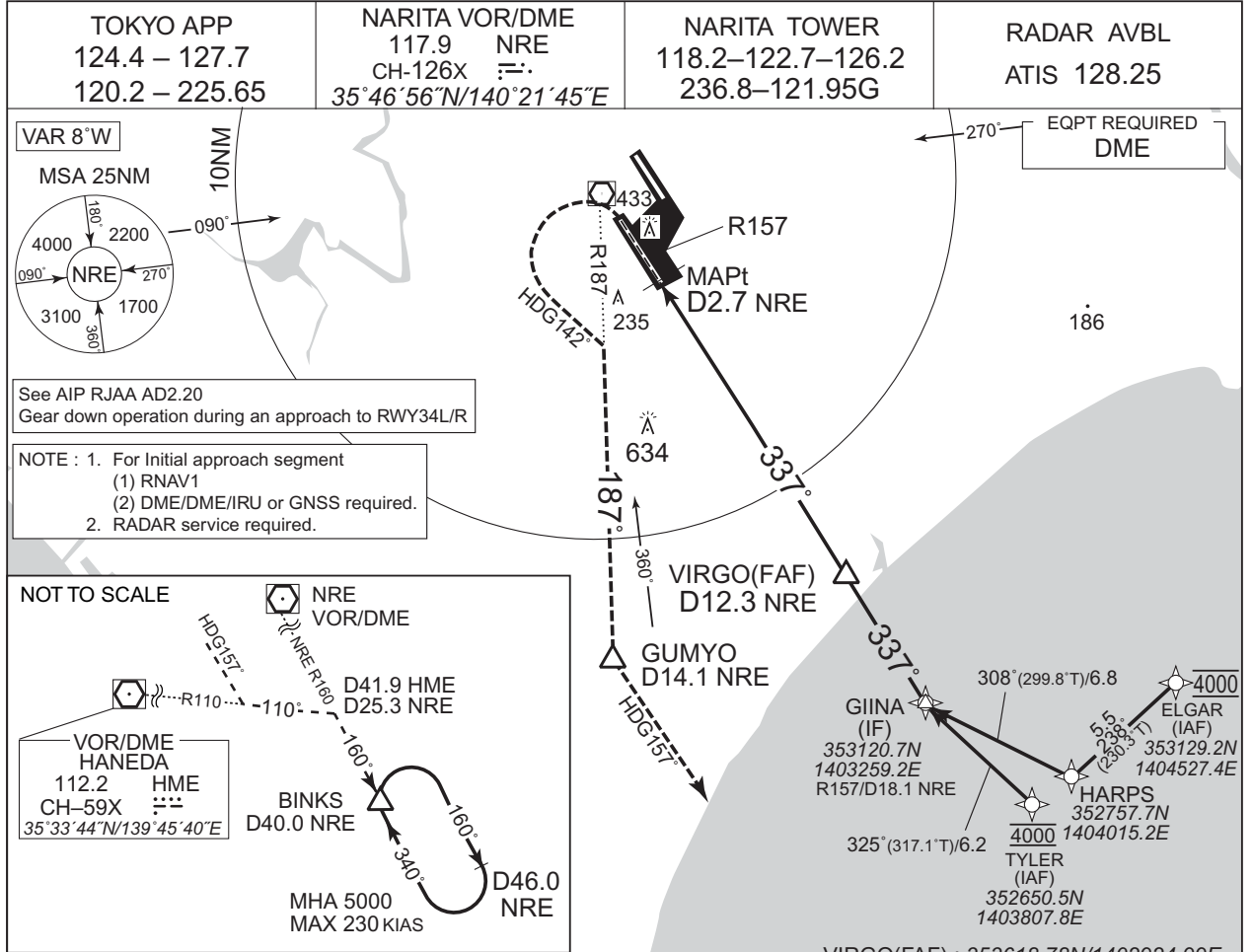

NM to NRE	MAPt	4	5	6	7	8	9	10	11	12	FAF
ALT (3.0° APCH Path)	-	599	917	1235	1554	1872	2191	2509	2828	3146	3244

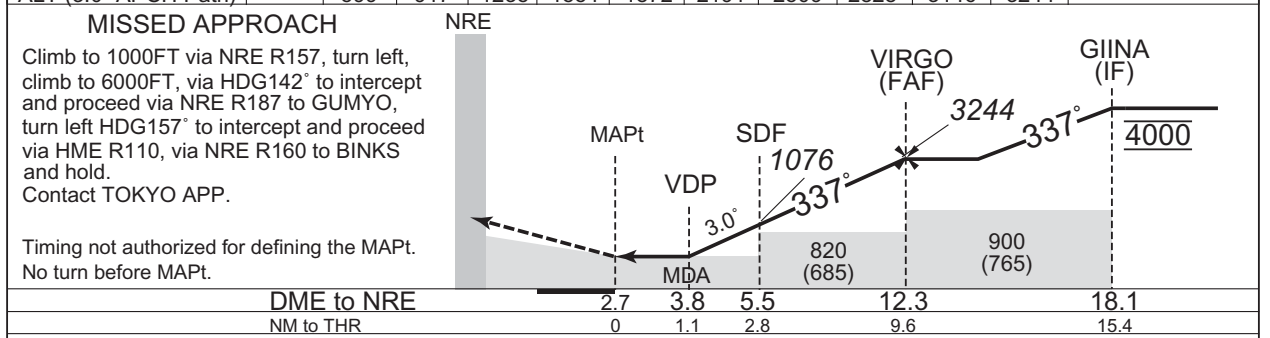

DME to NRE		2.7	3.8	5.5	12.3	18.1
NM to THR		0	1.1	2.8	9.6	15.4

MINIMA		THR elev. 139	AD elev. 135
CAT	CIRCLING		
	MDA(H)	RVR/CMV	MDA(H) VIS
	A	900	1600
	B	540 (405)	730 (595)
C	2400		
D	1400	3200	

CHANGE : Description of HLDG pattern.

INSTRUMENT APPROACH CHART

RJAA / NARITA INTL

ILS Z RWY34R

TOKYO APP 124.4 – 127.7 120.2 – 225.65	ILS – LOC 110.9 ITJ ̄--- ILS – GP 330.8 ILS – DME CH-46X	NARITA TOWER 118.35–122.7–126.2 236.8–121.85G	RADAR AVBL ATIS 128.25
--	---	---	---------------------------

Simultaneous approach authorized with RWY34L

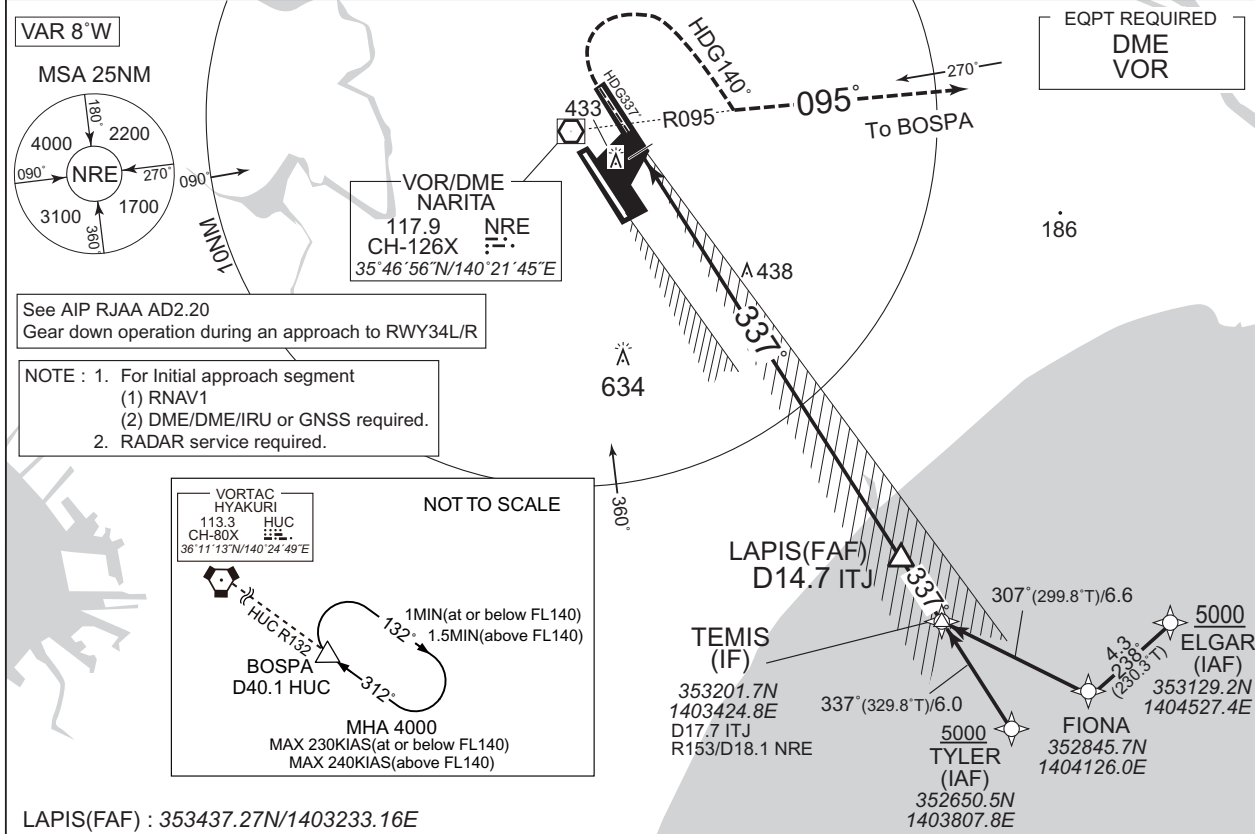

LAPIS(FAF) : 353437.27N/1403233.16E

MISSED APPROACH

Climb to 700FT on HDG337°, turn right HDG140° to intercept and proceed via NRE R095 to BOSPA and hold at 8000FT. Contact TOKYO APP.

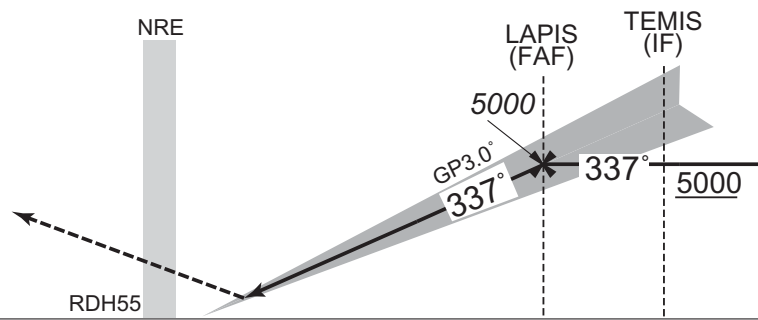

DME to ITJ
NM to THR

14.7 17.7
14.5 17.5

MINIMA		THR elev. 141	AD elev. 135	
CAT	CAT I		CIRCLING	
	DA(H)	RVR/CMV	MDA(H)	VIS
A	391 (250)	600	730 (595)	1600
B				2400
C				2400
D				3200

CHANGE : HLDG pattern(BOSPA).

INSTRUMENT APPROACH CHART

RJAA / NARITA INTL

ILS Y or LOC RWY34R

TOKYO APP 124.4 – 127.7 120.2 – 225.65	ILS – LOC 110.9 ITJ ILS – GP 330.8 ILS – DME CH-46X	NARITA TOWER 118.35–122.7–126.2 236.8–121.85G	RADAR AVBL ATIS 128.25
--	--	---	---------------------------

Simultaneous approach authorized with RWY34L

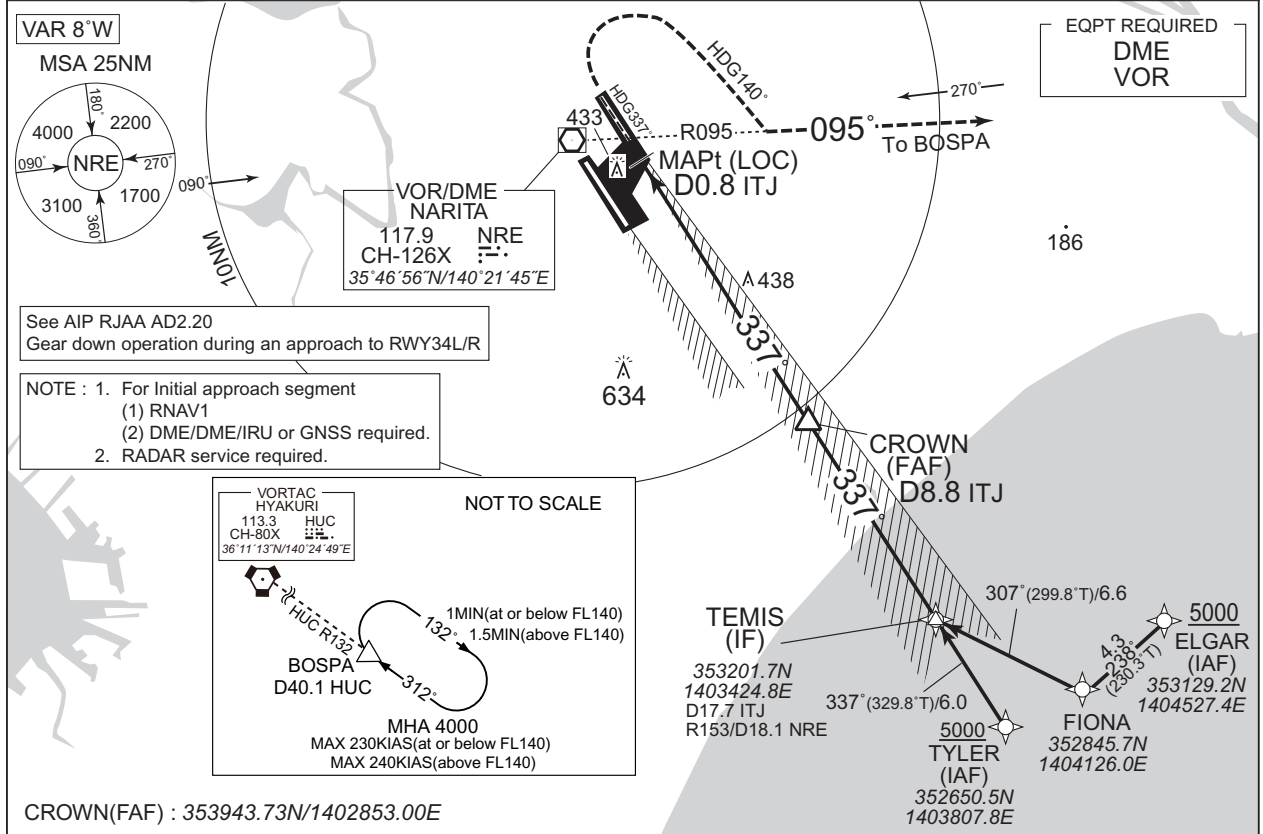

NM to ITJ	MAPt	2	3	4	5	6	7	8	FAF
ALT (3.0° APCH Path)	-	767	1086	1404	1723	2041	2360	2678	2926

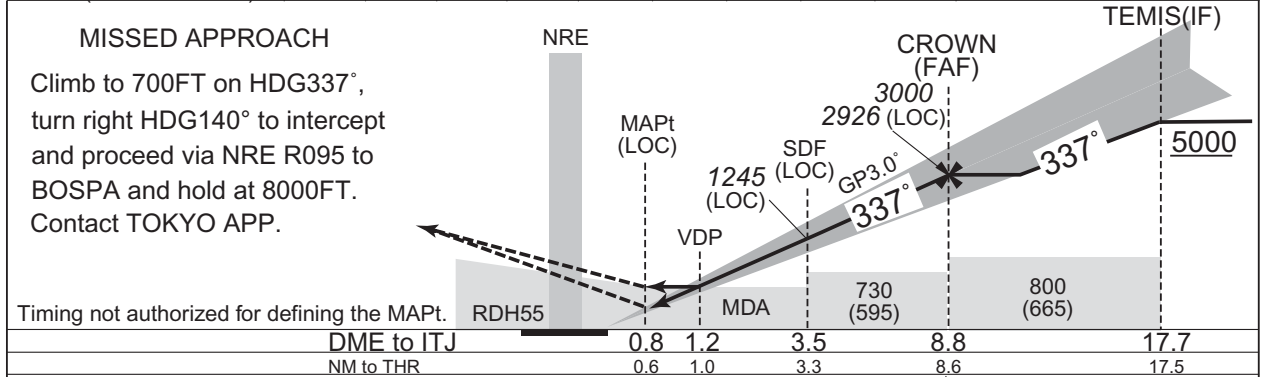

MINIMA		THR elev. 141		AD elev. 135		
CAT	CAT I		LOC		CIRCLING	
	DA(H)	RVR/CMV	MDA(H)	RVR/CMV	MDA(H)	VIS
A	391 (250)	600	510 (375)	900	730 (595)	1600
B				1000		
C				1400		
D				1400		

CHANGE : HLDG pattern(BOSPA).

INSTRUMENT APPROACH CHART

RJAA / NARITA INTL RNP RWY34R

TOKYO APP 124.4 – 127.7 120.2 – 225.65	RNP APCH	NARITA TOWER 118.35 –122.7–126.2 236.8–121.85G	RADAR AVBL ATIS 128.25
--	----------	--	---------------------------

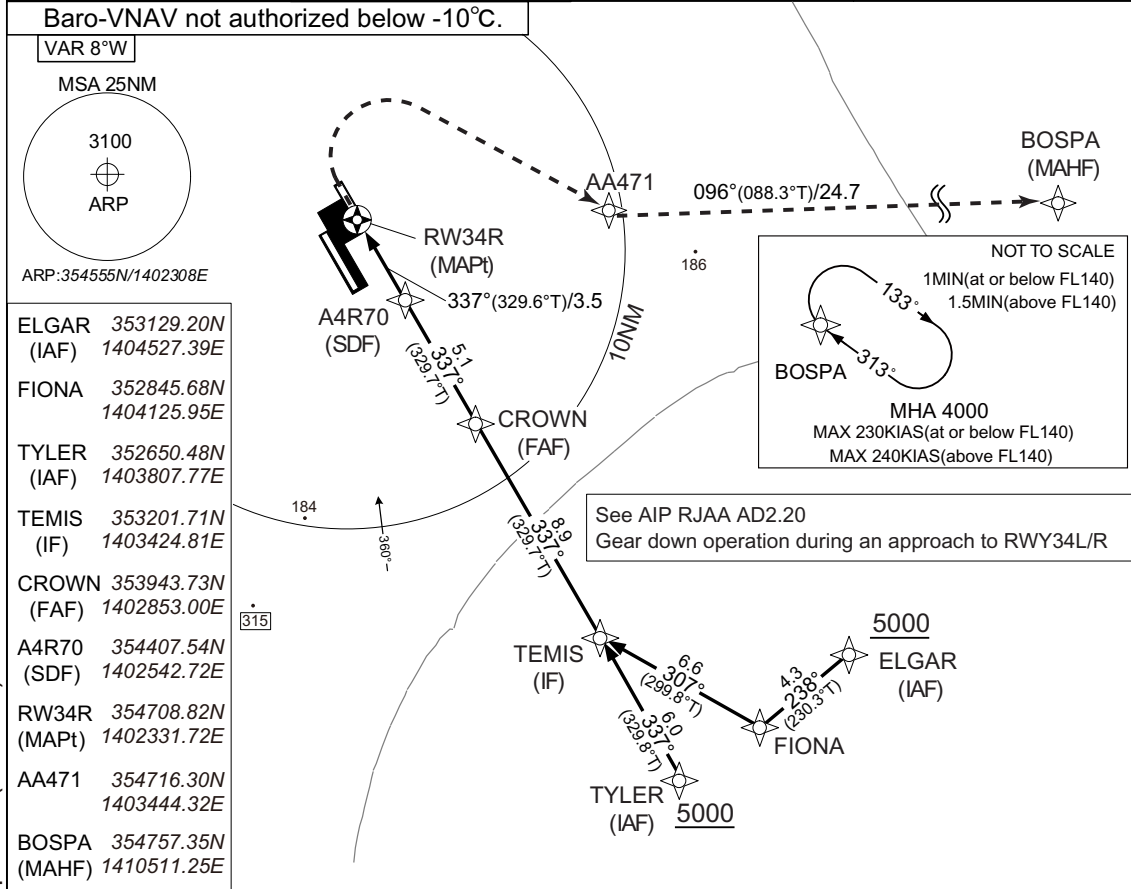

CHANGE : Missed APCH for using VOR/DME abolished. HLDG pattern(BOSPA).

NM to Next Fix	MAPt	2	3	4	5	6	7	8	FAF
ALT (3.0° APCH Path)	-	833	1151	1470	1788	2106	2454	2743	2932

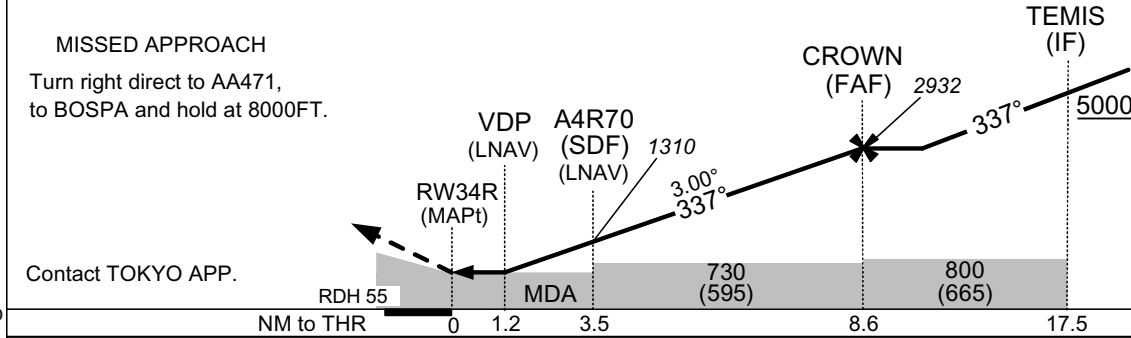

MINIMA		THR elev. 141		AD elev. 135		
CAT	LNAV/VNAV		LNAV		CIRCLING	
	DA(H)	RVR/CMV	MDA(H)	RVR/CMV	MDA(H)	VIS
A	560(419)	900	560(425)	900	730(595)	1600
B		1000		1000		
C		1000		1000		
D		1400		1400		

INSTRUMENT APPROACH CHART

RJAA / NARITA INTL

ILS Z RWY16R (CAT II & III)

TOKYO APP 124.4 – 127.7 120.2 – 225.65	ILS-LOC 111.5 IKF $\ddot{---}\ddot{---}$ ILS-GP 332.9 ILS-DME CH-52X	NARITA TOWER 118.2–122.7–126.2 236.8–121.95G	RADAR AVBL ATIS 128.25
--	---	--	---------------------------

Simultaneous approach authorized with RWY16L

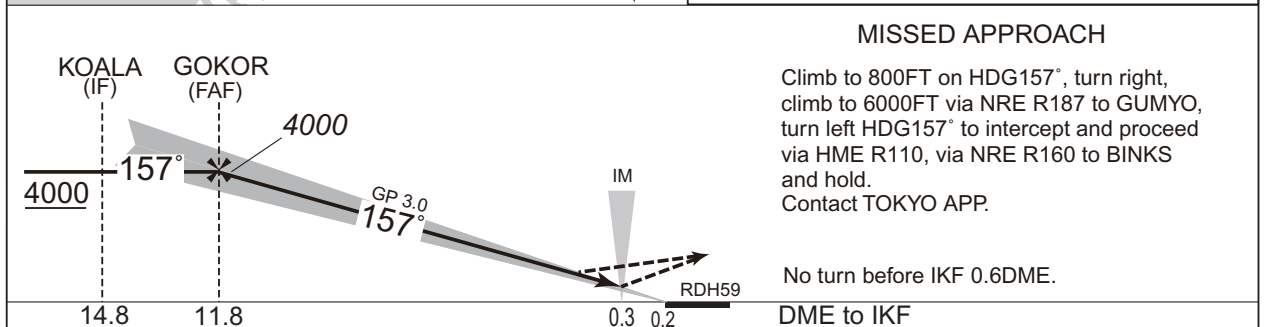
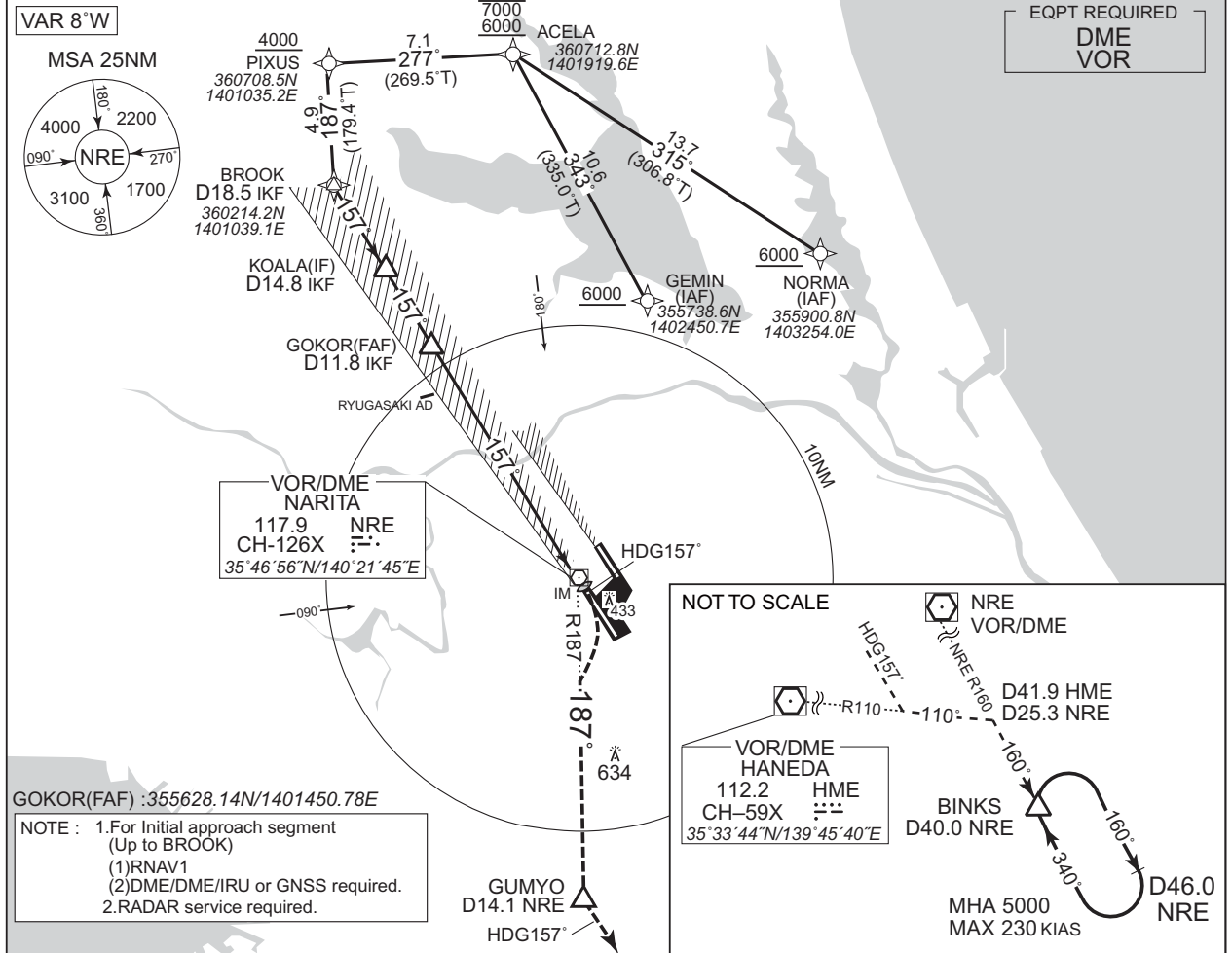

CAT	MINIMA		THR elev. 130			AD elev. 135		CIRCLING	
	RVR	DA(H)	RA	RVR	DA(H)	RVR/CMV	MDA(H)	VIS	
									CAT III
A								1600	
B	100	230 (100)	101	300	330 (200)	550	730 (595)	2400	
C								3200	
D									

CHANGE : Description of HLDG pattern.

INSTRUMENT APPROACH CHART

RJAA / NARITA INTL

ILS Y or LOC RWY16R (CAT II & III)

TOKYO APP 124.4 – 127.7 120.2 – 225.65	ILS-LOC 111.5 IKF $\equiv\equiv\equiv$ ILS-GP 332.9 ILS-DME CH-52X	NARITA TOWER 118.2-122.7-126.2 236.8-121.95G	RADAR AVBL ATIS 128.25
--	---	--	---------------------------

Simultaneous approach authorized with RWY16L

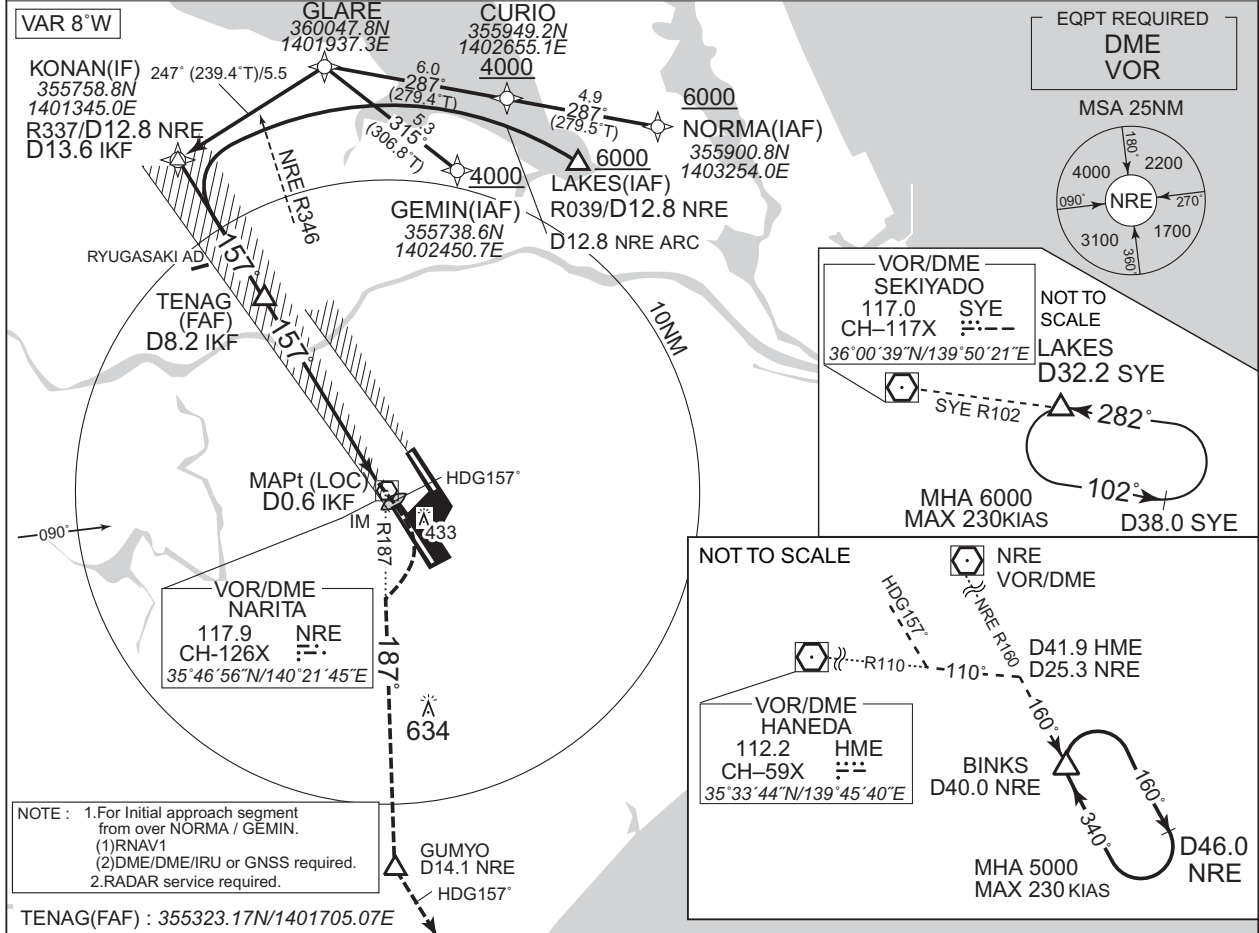

NM to IKF	FAF	8	7	6	5	4	3	2	MAPt
ALT (3.0° APCH Path)	2733	2667	2349	2030	1712	1393	1075	756	-

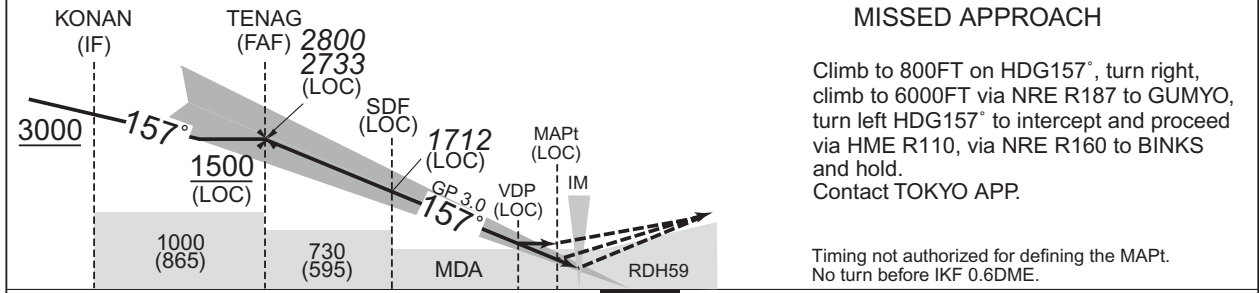

13.6	8.2	5.0	1.3	0.6	0.3	0.2	DME to IKF
13.4	8.0	4.8	1.1	0.4	0.2	0	NM to THR

MINIMA		THR elev. 130			AD elev. 135					
CAT	CAT III	CAT II		CAT I		LOC	CIRCLING			
	RVR	DA(H)	RA	RVR	DA(H)	RVR/CMV	MDA(H)	RVR/CMV	MDA(H)	VIS
A								900		1600
B		230	101	300	330	550	520	1000	730	2400
C	100	(100)			(200)		(385)		(595)	
D								1400		3200

CHANGE : Description of HLDG pattern.

INSTRUMENT APPROACH CHART

RJAA / NARITA INTL

VOR RWY16R

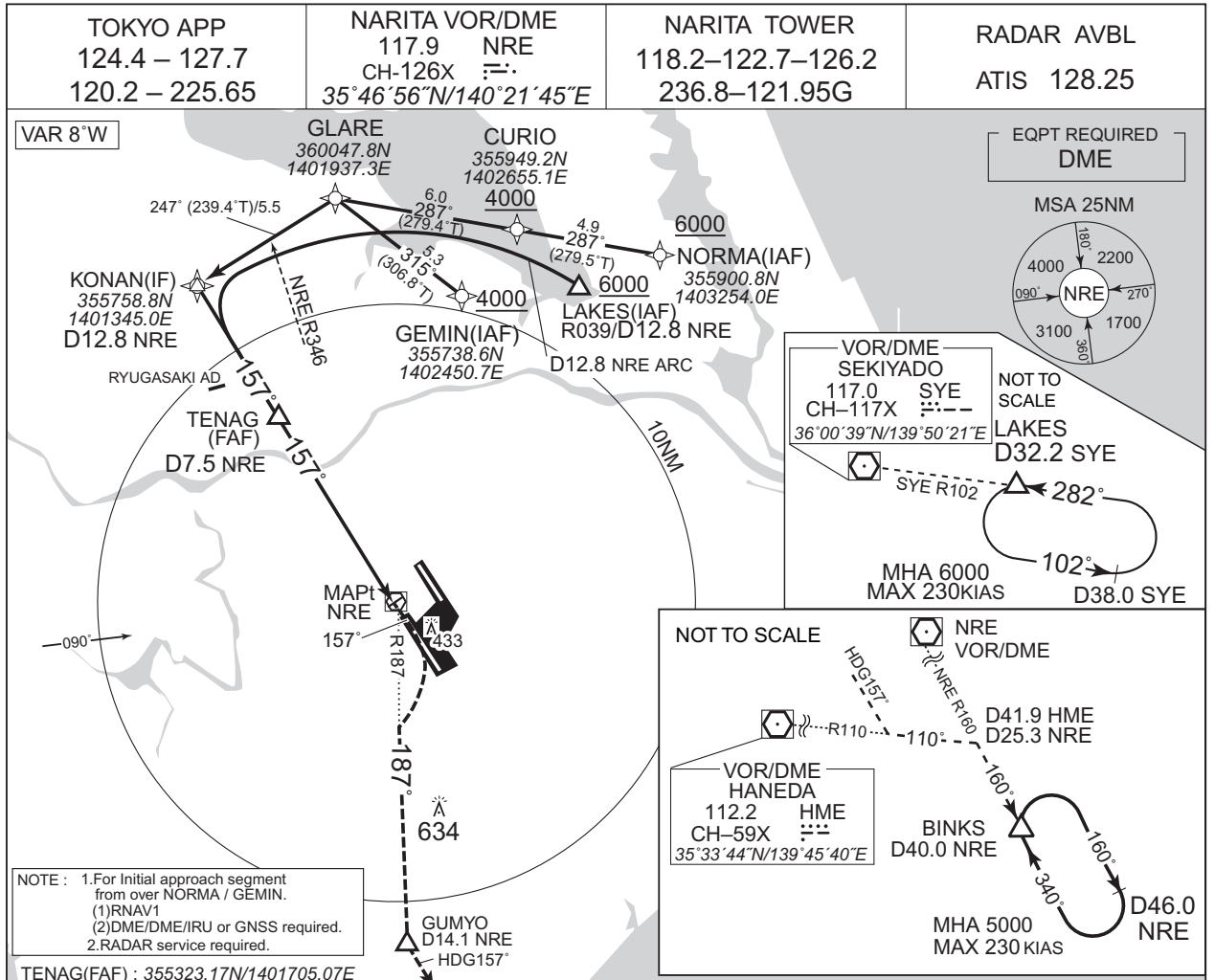

NM to NRE	FAF	7	6	5	4	3	2	1	MAPt
ALT (3.0° APCH Path)	2733	2584	2266	1947	1629	1310	992	673	-

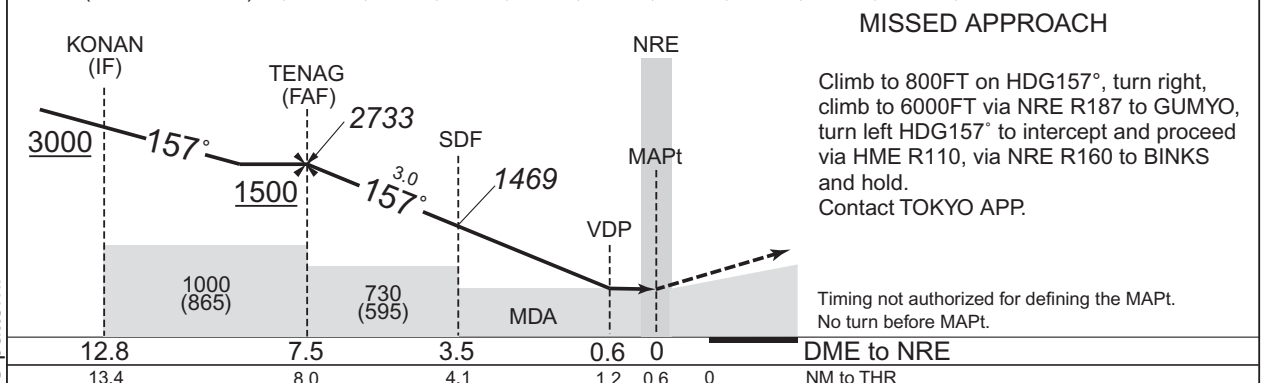

MINIMA		THR elev. 130		AD elev. 135	
CAT	MDA(H)	RVR/CMV	CIRCLING		
			MDA(H)	VIS	
	540 (405)	900	730 (595)	1600	
		1000		2400	
	1400		3200		

INSTRUMENT APPROACH CHART

RJAA / NARITA INTL

ILS Z RWY16L

TOKYO APP 124.4 – 127.7 120.2 – 225.65	ILS – LOC 110.7 ITM ILS – GP 330.2 ILS – DME CH-44X	NARITA TOWER 118.35 – 122.7 – 126.2 236.8 – 121.85G	RADAR AVBL ATIS 128.25
--	--	---	---------------------------

Simultaneous approach authorized with RWY16R

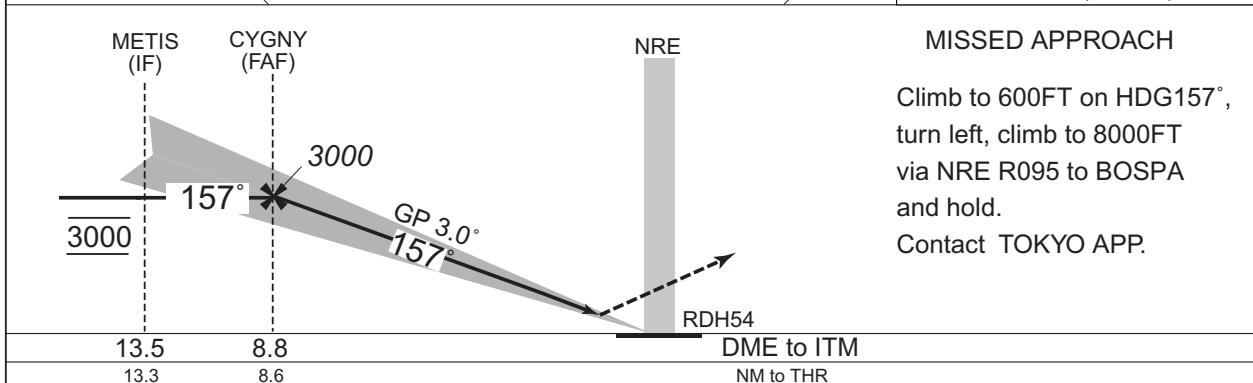
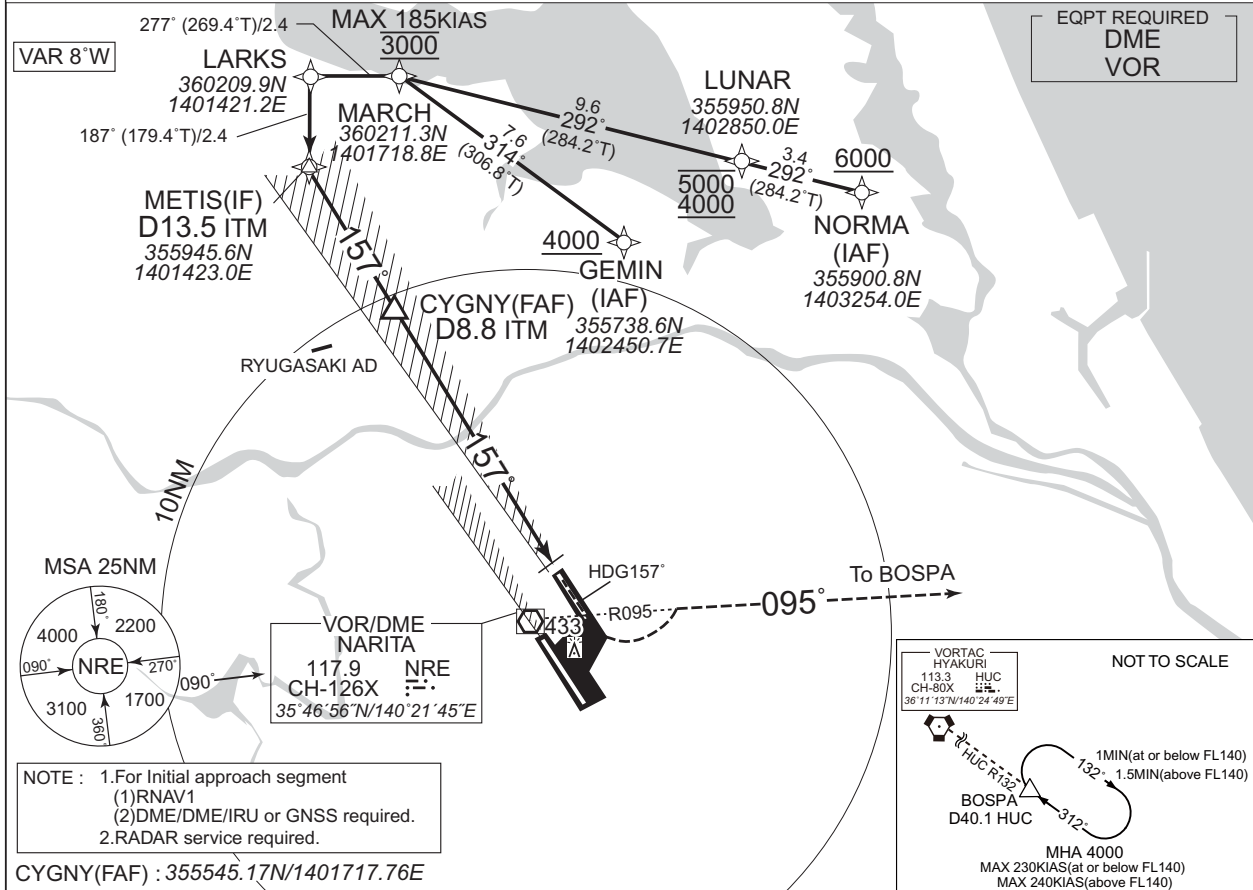

CHANGE : HLDG pattern(BOSPA).

MINIMA		THR elev. 135	AD elev. 135	
CAT	CAT I		CIRCLING	
	DA(H)	RVR/CMV	MDA(H)	VIS
A	335 (200)	550	730 (595)	1600
B				2400
C				2400
D				3200

INSTRUMENT APPROACH CHART

RJAA / NARITA INTL

ILS Y or LOC Y RWY16L

TOKYO APP 124.4 – 127.7 120.2 – 225.65	ILS – LOC 110.7 ITM ILS – GP 330.2 ILS – DME CH-44X	NARITA TOWER 118.35 – 122.7 – 126.2 236.8 – 121.85G	RADAR AVBL ATIS 128.25
--	--	---	---------------------------

Simultaneous approach authorized with RWY16R

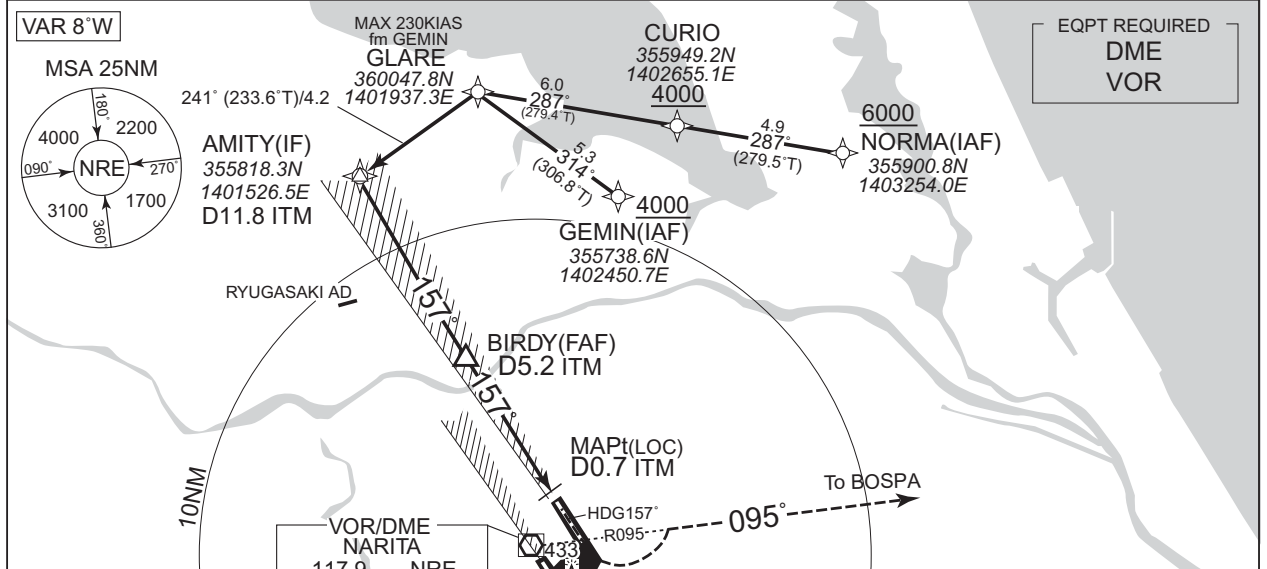

BIRDY(FAF) : 355236.92N/1401934.27E

NM to ITM	FAF	5	4	3	2	MAPt
ALT (3.0° APCH Path)	1771	1712	1394	1075	757	-

VORTAC
HYAKURI
113.3 HUC
CH-80X
36°11'13"N/140°24'49"E

NOT TO SCALE

BOSPA
D40.1 HUC

MHA 4000
MAX 230KIAS(at or below FL140)
MAX 240KIAS(above FL140)

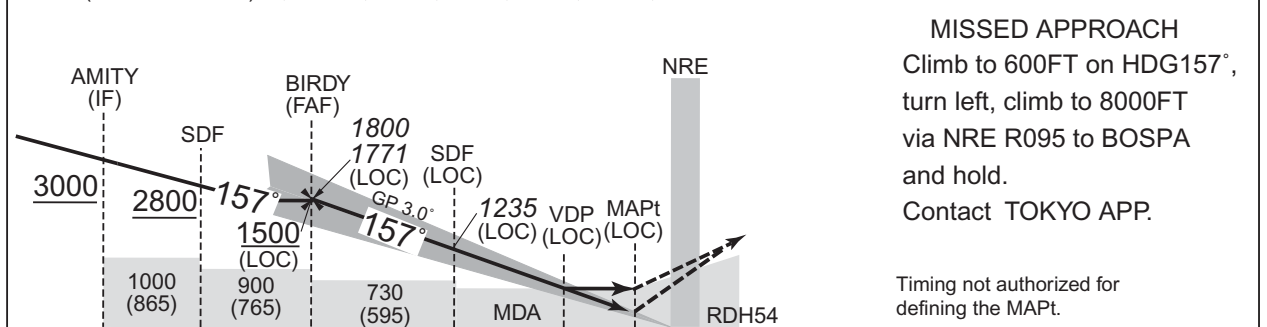

						DME to ITM
						NM to THR

CHANGE : HLDG pattern(BOSPA).	MINIMA		THR elev. 135		AD elev. 135		
	CAT I		LOC		CIRCLING		
	CAT	DA(H)	RVR/CMV	MDA(H)	RVR/CMV	MDA(H) VIS	
	A	335 (200)	550	510 (375)	900	730 (595)	1600
	B				1000		
C	1400				2400		
D	3200						

INSTRUMENT APPROACH CHART

RJAA / NARITA INTL

ILS X or LOC X RWY16L

TOKYO APP 124.4 – 127.7 120.2 – 225.65	ILS – LOC 110.7 ITM ILS – GP 330.2 ILS – DME CH-44X	NARITA TOWER 118.35 – 122.7 – 126.2 236.8 – 121.85G	RADAR AVBL ATIS 128.25
--	--	---	---------------------------

Simultaneous approach authorized with RWY16R

VAR 8°W

MSA 25NM

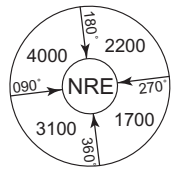

EQPT REQUIRED
DME
VOR

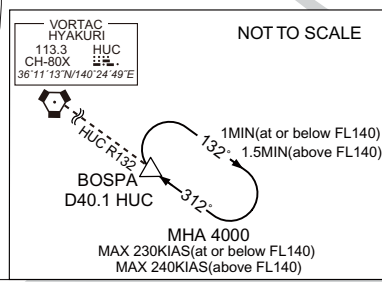
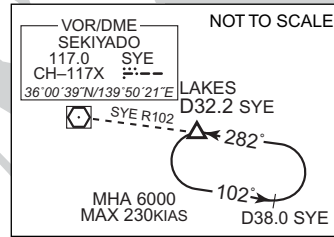
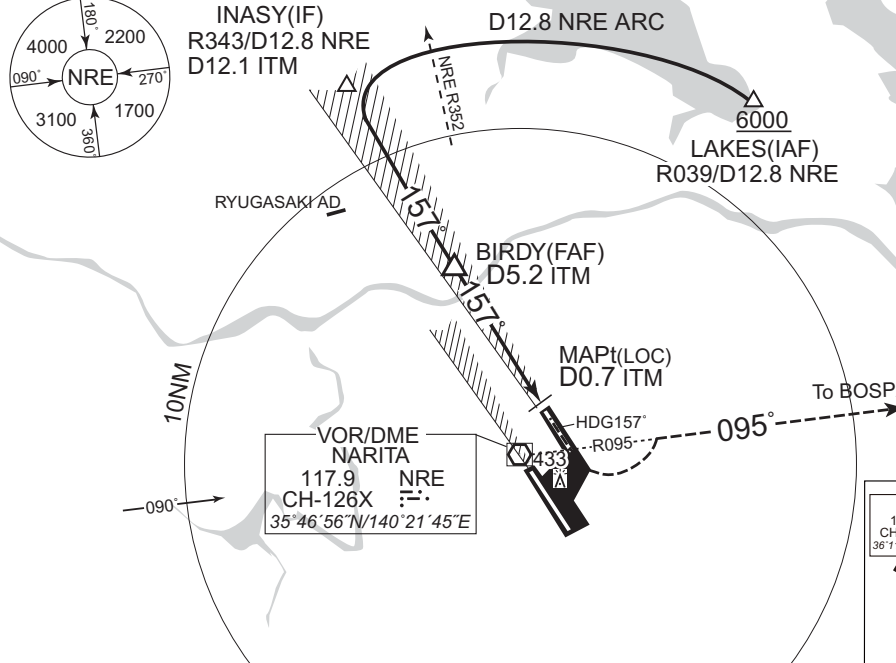

BIRDY (FAF) : 355236.92N/1401934.27E

NM to ITM	FAF	5	4	3	2	MAPt
ALT (3.0° APCH Path)	1771	1712	1394	1075	757	-

MISSED APPROACH
Climb to 600FT on HDG157°, turn left, climb to 8000FT via NRE R095 to BOSPA and hold.
Contact TOKYO APP.

Timing not authorized for defining the MAPt.

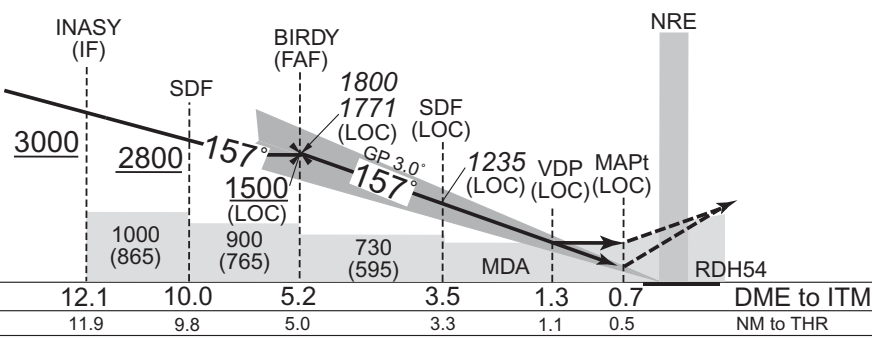

CHANGE : HLDG pattern(BOSPA).

MINIMA		THR elev. 135		AD elev. 135			
CAT	CAT I		LOC		CIRCLING		
	DA(H)	RVR/CMV	MDA(H)	RVR/CMV	MDA(H)	VIS	
A	335 (200)	550	510 (375)	900	730 (595)	1600	
B				1000			
C				1400			2400
D				3200			

INSTRUMENT APPROACH CHART

RJAA / NARITA INTL

RNP RWY16L

TOKYO APP 124.4 – 127.7 120.2 – 225.65	RNP APCH	NARITA TOWER 118.35 – 122.7 – 126.2 236.8 – 121.85G	RADAR AVBL ATIS 128.25
--	----------	---	---------------------------

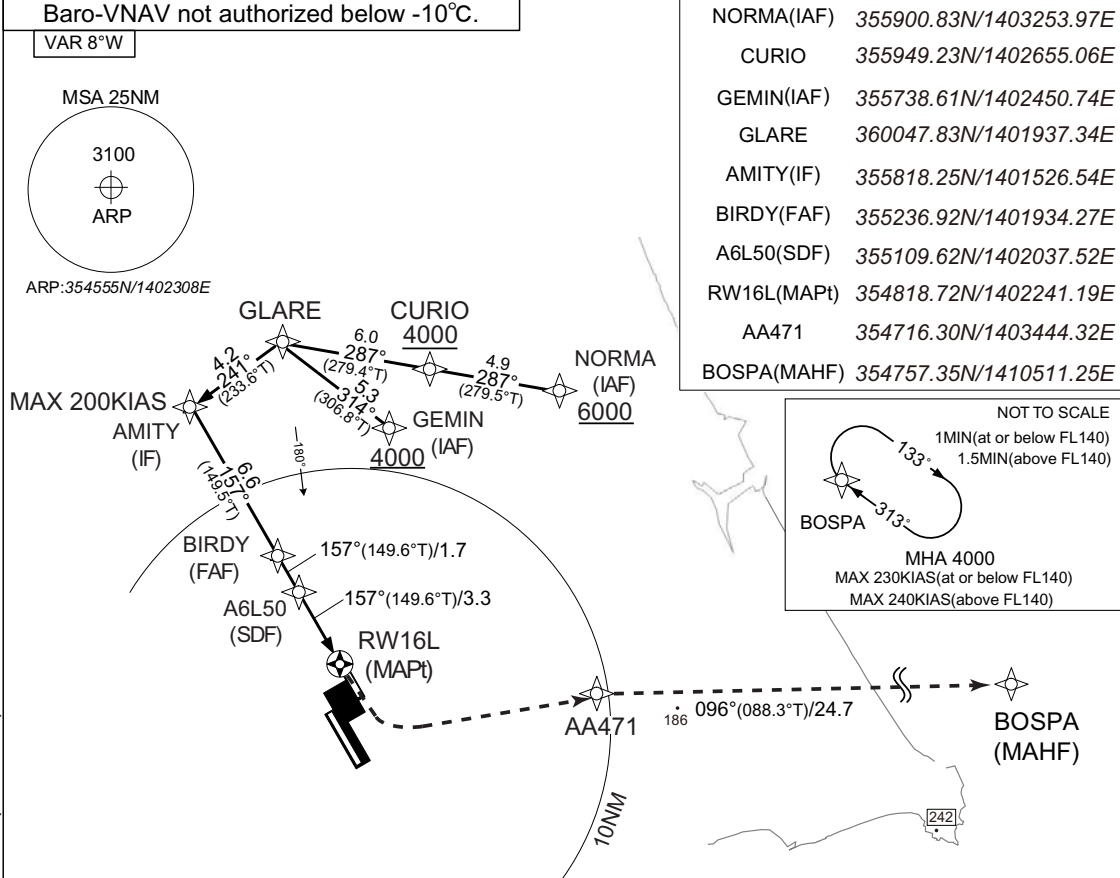

NM to Next Fix	FAF	4	3	2	MAPt
ALT (3.0° APCH Path)	1777	1462	1144	826	-

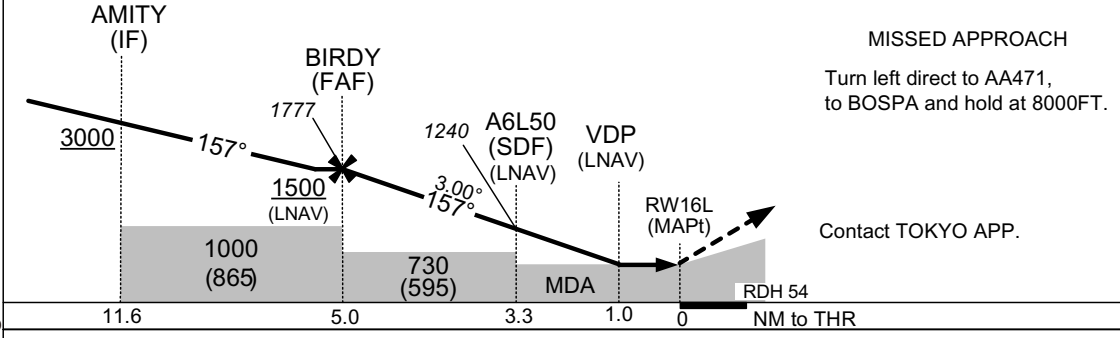

MINIMA		THR elev. 135		AD elev. 135		
CAT	LNAV/VNAV		LNAV		CIRCLING	
	DA(H)	RVR/CMV	MDA(H)	RVR/CMV	MDA(H)	VIS
A	490(355)	900	490(355)	900	730(595)	1600
B		1000		1000		2400
C		1400		1400		3200
D						

CHANGE : Missed APCH for using VOR/DME abolished. HLDG pattern(BOSPA).

INTENTIONALLY LEFT BLANK

RJAA / NARITA INTL

HLDG PATTERN

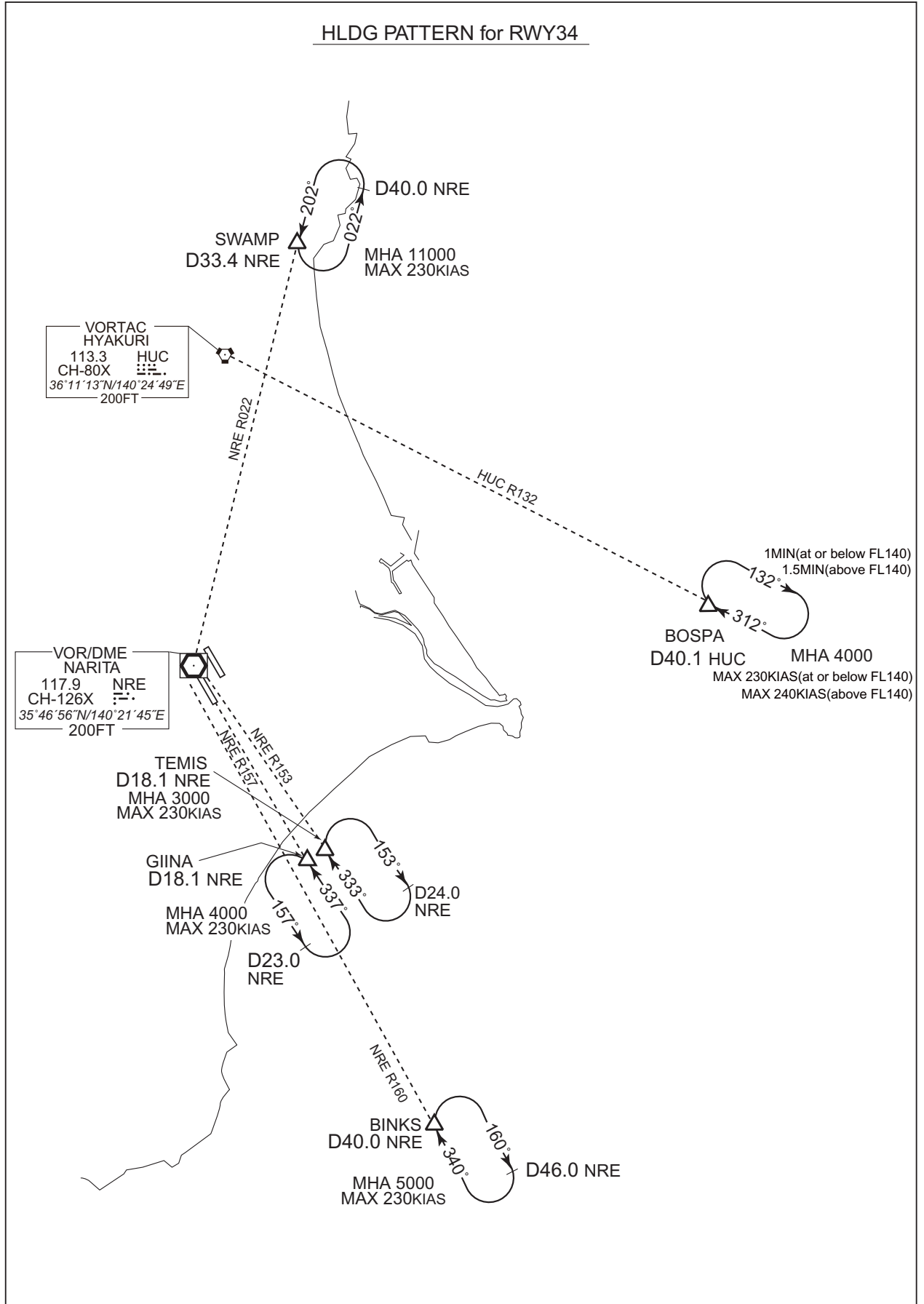

RJAA / NARITA INTL

HLDG PATTERN

HLDG PATTERN for RWY16

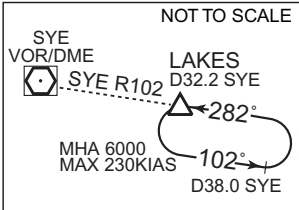
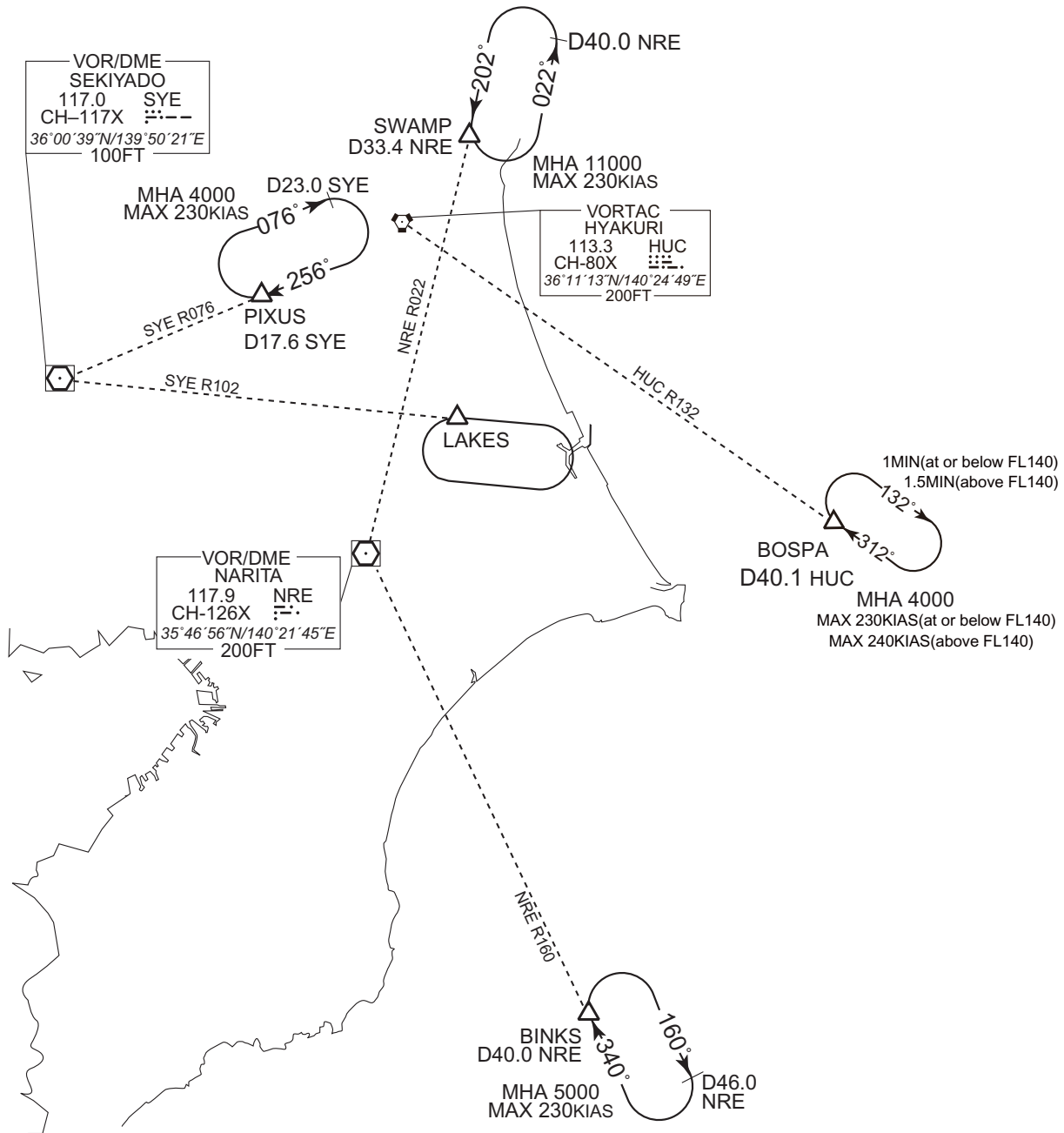

CHANGE : HLDG pattern(BOSPA).

RJAA / NARITA INTL

RNAV HLDG PATTERN

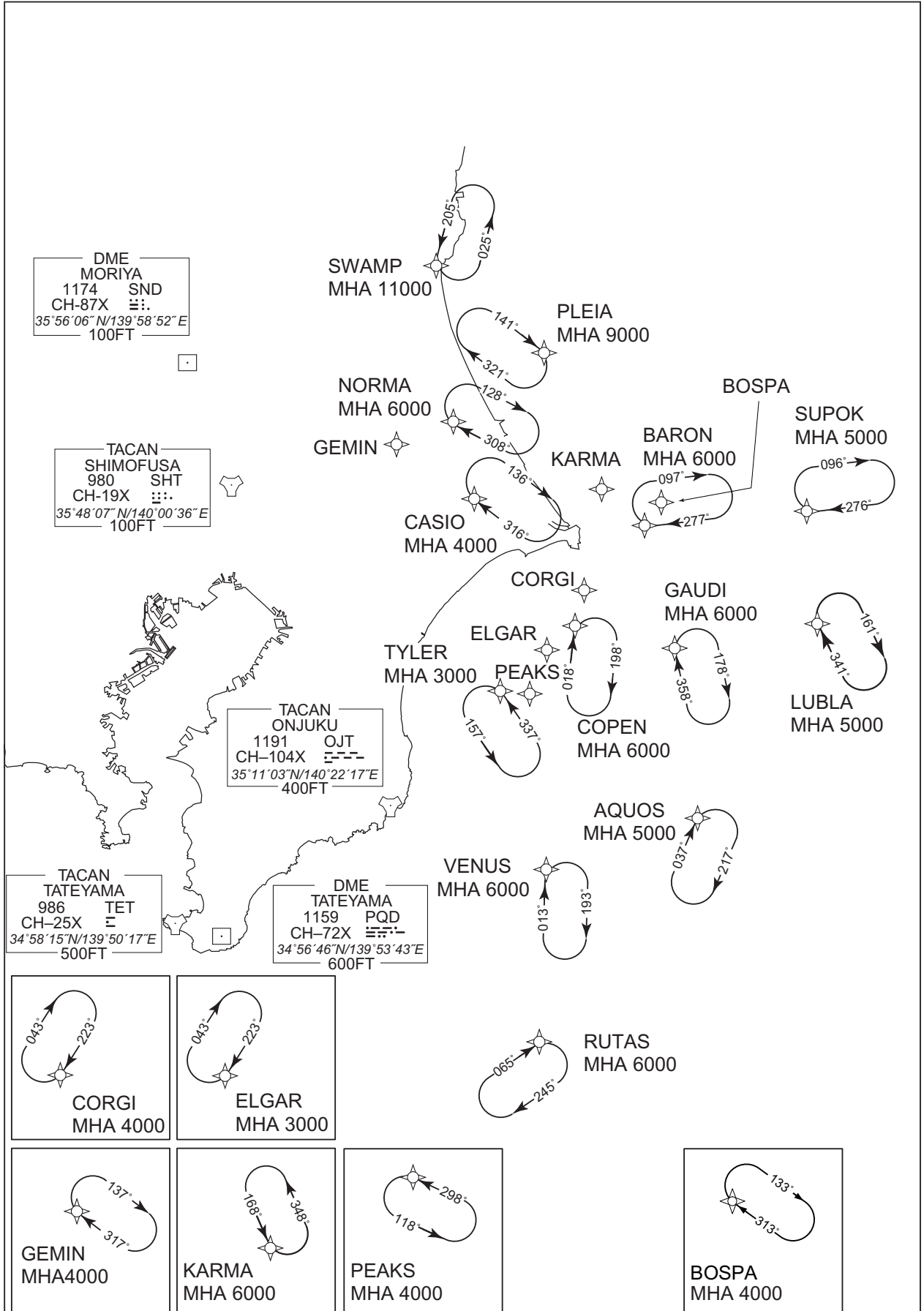

CHANGE : HLDG pattern(BOSPA) added.

RJAA / NARITA INTL

RNAV HLDG PATTERN

Path	Waypoint Identifier	Inbound Course °M(°T)	Magnetic Variation	Outbound Time (MIN)	Outbound Distance (NM)	Turn Direction	Minimum Altitude (FT)	Maximum Altitude (FT)	Speed (KIAS)	Navigation Specification
Hold	AQUOS	037 (029.1)	-7.5	1.0(-14000) 1.5(+14001)	—	R	5000	—	-230(-14000) -240(+14001)	RNAV1
Hold	BARON	277 (270.0)	-7.5	1.0(-14000) 1.5(+14001)	—	R	6000	—	-230(-14000) -240(+14001)	RNAV1
Hold	CASIO	316 (308.6)	-7.5	1.0(-14000) 1.5(+14001)	—	R	4000	—	-230(-14000) -240(+14001)	RNAV1
Hold	COPEN	018 (010.5)	-7.5	1.0(-14000) 1.5(+14001)	—	R	6000	—	-230(-14000) -240(+14001)	RNAV1
Hold	CORGI	223 (215.8)	-7.5	1.0(-14000) 1.5(+14001)	—	R	4000	—	-230(-14000) -240(+14001)	RNAV1
Hold	ELGAR	223 (215.7)	-7.5	1.0(-14000) 1.5(+14001)	—	R	3000	—	-230(-14000) -240(+14001)	RNAV1
Hold	GAUDI	358 (351.0)	-7.5	1.0(-14000) 1.5(+14001)	—	R	6000	—	-230(-14000) -240(+14001)	RNAV1
Hold	GEMIN	317 (309.1)	-7.5	1.0(-14000) 1.5(+14001)	—	R	4000	—	-230(-14000) -240(+14001)	RNAV1
Hold	KARMA	168 (160.3)	-7.5	1.0(-14000) 1.5(+14001)	—	L	6000	—	-230(-14000) -240(+14001)	RNAV1
Hold	LUBLA	341 (333.9)	-7.5	1.0(-14000) 1.5(+14001)	—	R	5000	—	-230(-14000) -240(+14001)	RNAV1
Hold	NORMA	308 (300.0)	-7.5	1.0(-14000) 1.5(+14001)	—	R	6000	—	-230(-14000) -240(+14001)	RNAV1
Hold	PEAKS	298 (290.2)	-7.5	1.0(-14000) 1.5(+14001)	—	L	4000	—	-230(-14000) -240(+14001)	RNAV1
Hold	PLEIA	141 (133.1)	-7.5	1.0(-14000) 1.5(+14001)	—	R	9000	—	-230(-14000) -240(+14001)	RNAV1
Hold	RUTAS	065 (057.9)	-7.5	1.0(-14000) 1.5(+14001)	—	R	6000	—	-230(-14000) -240(+14001)	RNAV1
Hold	SUPOK	276 (268.6)	-7.5	1.0(-14000) 1.5(+14001)	—	R	5000	—	-230(-14000) -240(+14001)	RNAV1
Hold	SWAMP	205 (197.0)	-7.5	1.0(-14000) 1.5(+14001)	—	L	11000	—	-230(-14000) -240(+14001)	RNAV1
Hold	TYLER	337 (329.8)	-7.5	1.0(-14000) 1.5(+14001)	—	L	3000	—	-230(-14000) -240(+14001)	RNAV1
Hold	VENUS	013 (005.8)	-7.5	1.0(-14000) 1.5(+14001)	—	R	6000	—	-230(-14000) -240(+14001)	RNAV1

Path	Waypoint Identifier	Inbound Course °M(°T)	Magnetic Variation	Outbound Time (MIN)	Turn Direction	Minimum Altitude (FT)	Maximum Altitude (FT)	Speed (KIAS)
Hold	BOSPA	313 (305.7)	-7.8	1.0(-14000) 1.5(+14001)	R	4000	—	-230(-14000) -240(+14001)

CHANGE : HLDG pattern(BOSPA) added.

RJAA / NARITA INTL

RNAV HLDG PATTERN

Waypoint Coordinates

Waypoint Identifier	Coordinates	Waypoint Identifier	Coordinates
AQUOS	351229.7N / 1410942.5E	LUBLA	353235.0N / 1412550.8E
BARON	354551.0N / 1410112.0E	NORMA	355900.8N / 1403254.0E
CASIO	355021.4N / 1403556.1E	PEAKS	352507.2N / 1404352.7E
COPEN	353303.7N / 1404939.2E	PLEIA	360734.8N / 1404745.4E
CORGI	353829.8N / 1405138.9E	RUTAS	344349.3N / 1404034.2E
ELGAR	353129.2N / 1404527.4E	SUPOK	354614.1N / 1412810.0E
GAUDI	353002.4N / 1410418.1E	SWAMP	361914.4N / 1403217.0E
GEMIN	355738.6N / 1402450.7E	TYLER	352650.5N / 1403807.8E
KARMA	355042.9N / 1405512.4E	VENUS	350440.1N / 1404309.7E

Waypoint Identifier	Coordinates
BOSPA	354757.4N / 1410511.3E

CHANGE : BOSPA added.

RJAA / NARITA INTL

Visual REP

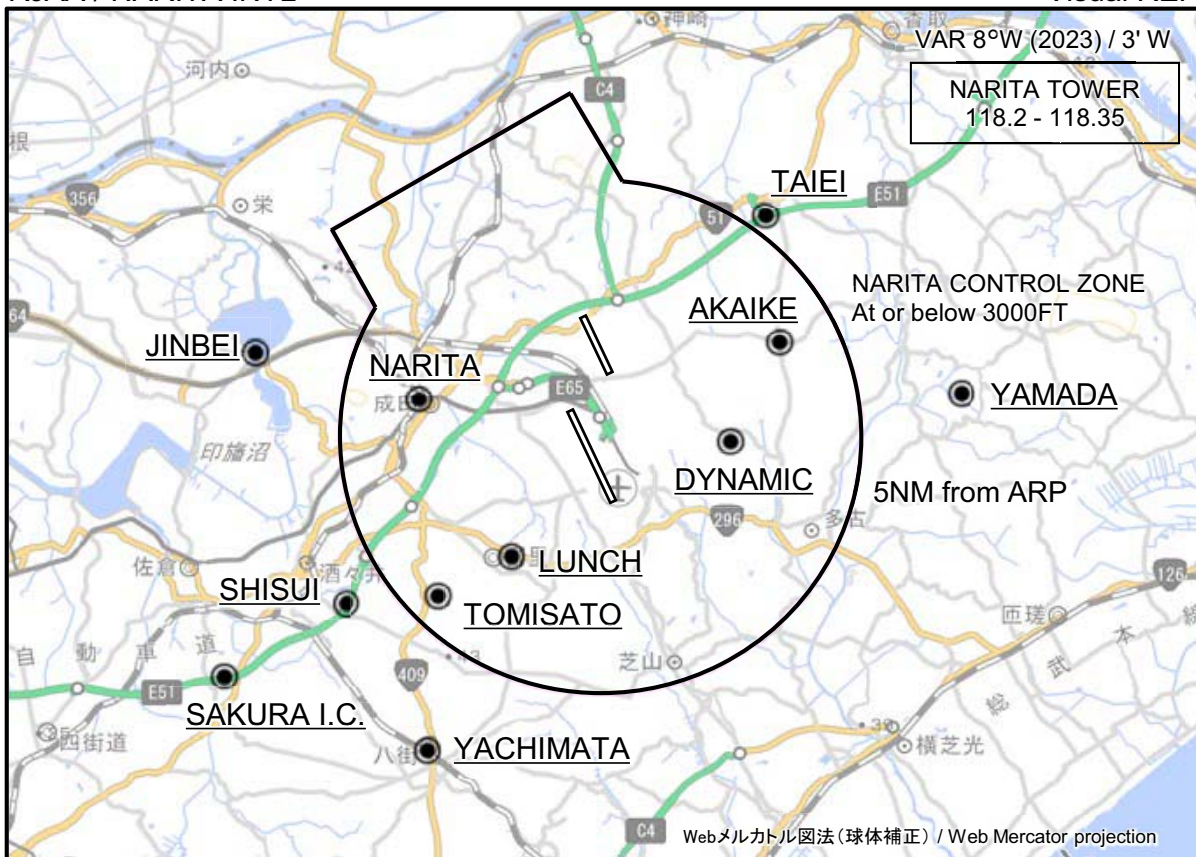

※図中に標高を示す数字がある場合、単位はメートル(m)である。The unit of measurement used to express elevation is meter(m).

CHANGE : Visual REP abolished(Radisson).

Call sign	BRG / DIST from ARP	Remarks
大栄 Taiei	036°T / 5.3NM	東関東自動車道大栄インターチェンジ Interchange
赤池 Akaike	061°T / 3.9NM	赤池交差点 Akaike Intersection
甚兵衛 Jinbei	284°T / 6.8NM	甚兵衛大橋 Jinbei Bridge
山田 Yamada	083°T / 7.0NM	山田ARSRサイト Yamada ARSR Site
成田 Narita	282°T / 3.6NM	JR成田駅 JR Narita Station
ダイナミック Dynamic	092°T / 2.5NM	ダイナミックゴルフ倶楽部クラブハウス Dynamic Golf Club House
ランチ Lunch	216°T / 2.9NM	給食センター Lunch Center
富里 Tomisato	225°T / 4.4NM	富里第二工業団地 Industrial Park
酒々井 Shisui	236°T / 5.9NM	酒々井パーキングエリア Parking Area
佐倉インターチェンジ Sakura Interchange	237°T / 8.6NM	東関東自動車道佐倉インターチェンジ Interchange
八街 Yachimata	208°T / 7.0NM	JR八街駅 JR Station

RJAA / NARITA INTL LDG CHART (Trees existence on final approach area of Runway 34R)

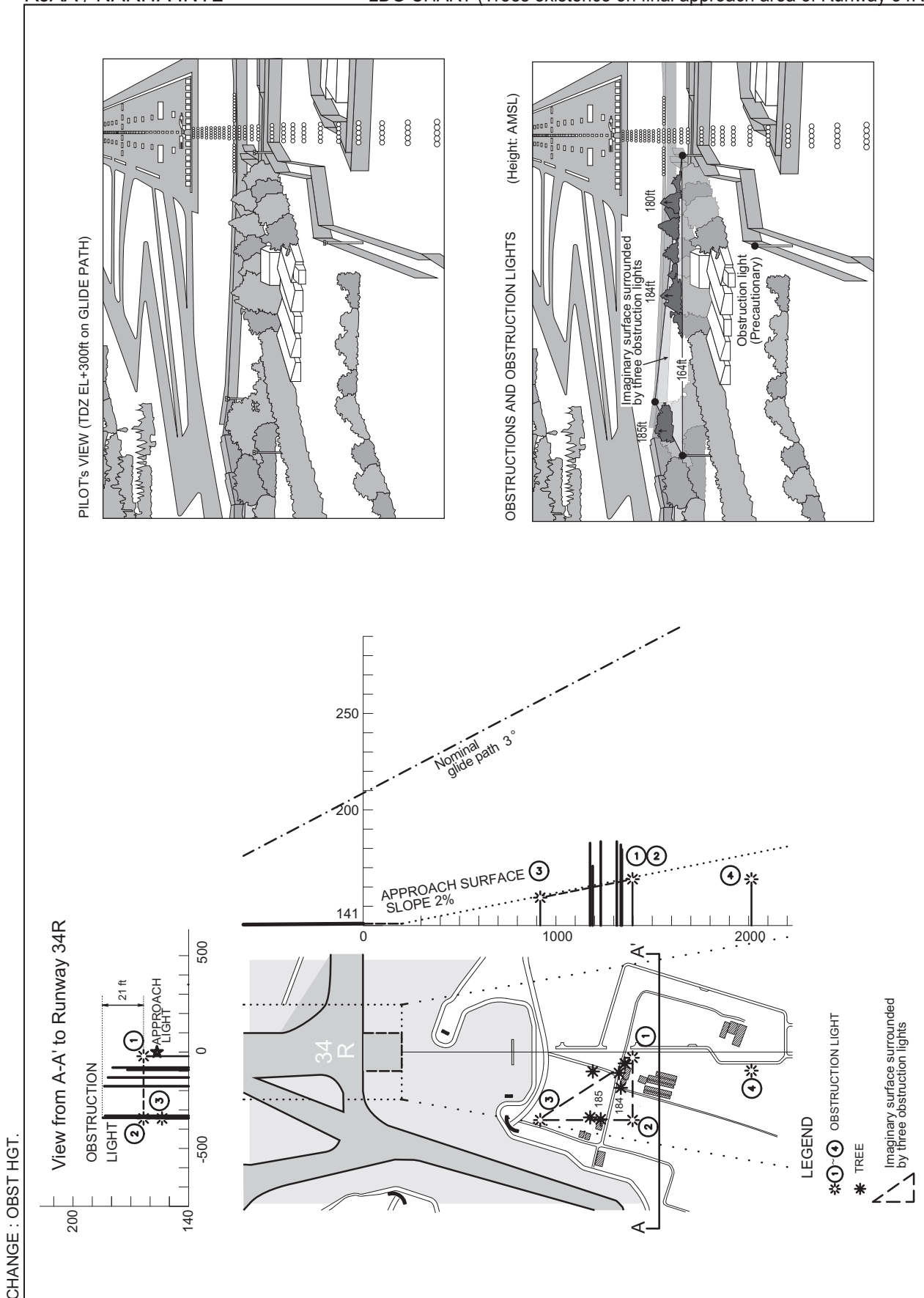

RJAA / NARITA INTL

Minimum Vectoring Altitude CHART

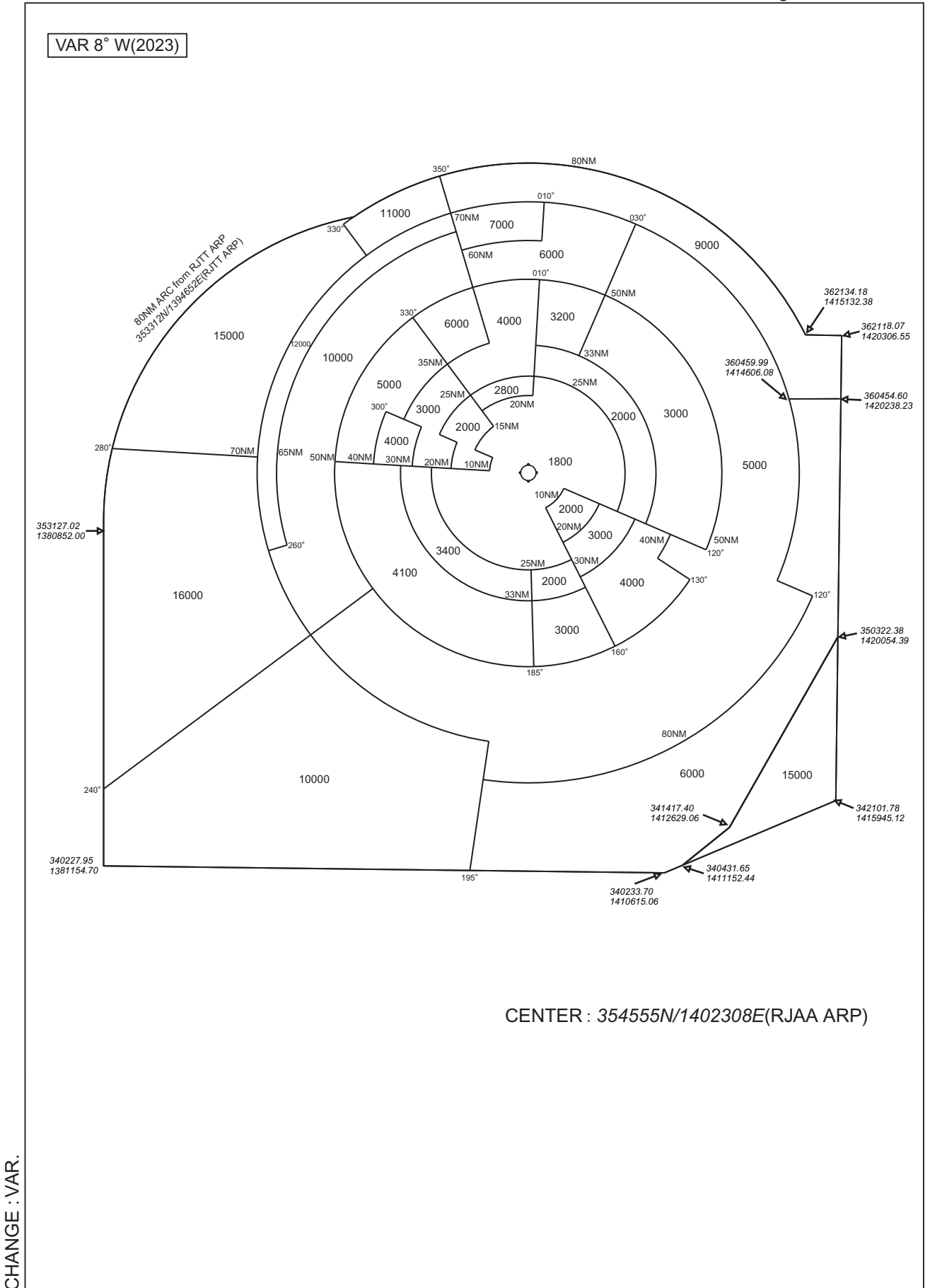

INTENTIONALLY LEFT BLANK