

AD 2 AERODROMES

RJBB AD 2.1 AERODROME LOCATION INDICATOR AND NAME

RJBB - KANSAI International

RJBB AD 2.2 AERODROME GEOGRAPHICAL AND ADMINISTRATIVE DATA

1	ARP coordinates and site at AD	342603N/1351358E 76° 11'2.53km from RWY 06L THR
2	Direction and distance from (city)	38km (20.5nm) SW of Osaka Station (Japan Railway)
3	Elevation/ Reference temperature	17.4ft / 31.8°C (2001-2005)
4	Geoid undulation at AD ELEV PSN	123ft
5	MAG VAR/Annual change	8° W (2023) / 5.0'W
6	AD Administration, address, telephone, telefax, telex, AFS, e-mail and/or Web-site addresses	Kansai Airports 1-Banchi, Senshu-kuko Kita Izumisano-city Osaka, Japan. Tel: 072-455-2221 FAX: 072-455-2055 AFS: RJBBYDYX E-mail:ops@kansai-airports.co.jp Web-site: http://www.kansai-airports.co.jp/
7	Types of traffic permitted(IFR/ VFR)	IFR/VFR
8	Remarks	Kansai Airport Office (CAB) 1-Banchi, Senshu-kuko Naka, Tajiri-cho, Sennan-gun, Osaka, Japan Tel: 072-455-1300, 050-3198-2867 (AIS)

RJBB AD 2.3 OPERATIONAL HOURS

1	AD Administration	H24
2	Customs and immigration	H24
3	Health and sanitation	H24
4	AIS Briefing Office	H24
5	ATS Reporting Office(ARO)	Nil
6	MET Briefing Office	H24
7	ATS	H24
8	Fuelling	H24
9	Handling	H24
10	Security	H24
11	De-icing	Nil
12	Remarks	Nil

RJBB AD 2.4 HANDLING SERVICES AND FACILITIES

1	Cargo-handling facilities	All the modern institutions that deal with the weight thing to a Boeing747 type freighter
2	Fuel/ oil types	Fuel grades: JET A-1 Oil grades: All turbine grades
3	Fuelling facilities/ capacity	Hydrant refueling Hydrant refueling is unserviceable on every Sunday(1730-1930UTC) due to scheduled inspection. Check with service companies for alternative solution.
4	De-icing facilities	Nil
5	Hangar space for visiting aircraft	Nil
6	Repair facilities for visiting aircraft	Nil
7	Remarks	Nil

RJBB AD 2.5 PASSENGER FACILITIES

1	Hotels	At Airport
2	Restaurants	At Airport
3	Transportation	Railways, Buses, Taxis and Ships
4	Medical facilities	First aid treatment, ambulance; hospital in Izumisano City 8km
5	Bank and Post Office	At Airport
6	Tourist Office	At Airport
7	Remarks	Nil

RJBB AD 2.6 RESCUE AND FIRE FIGHTING SERVICES

1	AD category for fire fighting	CAT 10
2	Rescue equipment	Chemical fire fighting truck x 5 Ambulance x 2 Water supply truck x 2 Rescue wrecking machinery and Lighting power supply truck Emergency medical equipments conveyance truck Foam solution transporter
3	Capability for removal of disabled aircraft	Nil
4	Remarks	Nil

RJBB AD 2.7 SEASONAL AVAILABILITY-CLEARING

1	Types of clearing equipment	Snow removal equipments:Motor graders
2	Clearance priorities	1) RWY 06R/24L, A1, A4, A11, A14, E1, R, P(E1-ROTOR CRAFT APRON), L(E9-A14), E9(R-L), J4(L-Z), S1, S4, S5, S6, T, Q, Z(spot 257-J4), HEL-PAD 2) RWY 06L/24R, B1, B14, Y, J3(S1-S4), J3(S4-S6), J3(S6-Y), J4(Y-Z)
3	Remarks	Seasonal availability: All seasons. Snow removal will be commenced, if the runways and taxiways are covered with a depth of 3cm or more. Any contaminants on runway center lines, landing strips and lighting aids shall be removed as and when necessary so as to provide good contact with the runways. TWY/APN to measure the coefficient of friction: TWY A1, A14, E1, R, P(E1-ROTOR CRAFT APRON), L(E9-A14), E9(R-L), J4(L-Z), S1, S4, S5, S6, T, Q, Z(spot 257-J4), HEL-PAD

RJBB AD 2.8 APRONS, TAXIWAYS AND CHECK LOCATIONS DATA

<p>1</p>	<p>Apron surface and strength</p>	<p>Apron: From spot 1 to spot 41, from spot 101 to spot 111, from spot 201 to spot 215 Surface: Cement-concrete, Strength: PCN 110/R/C/X/T From spot 80 to spot 90 Surface: Cement-concrete, Strength: PCN 91/R/B/X/T From spot 91 to spot 99 Surface: Cement-concrete, Strength: PCN 94/R/B/X/T, Surface: Asphalt-concrete, Strength: PCN 96/F/A/X/T From spot M2 to M9 Surface: Asphalt-concrete, Strength: PCN 80/F/B/X/T From spot 251 to 255 Surface: Cement-concrete, Strength: PCN 83/R/B/X/T From spot 256 to 257 Surface: Cement-concrete, Strength: PCN 99/R/B/X/T</p> <p>ACFT stand taxilane N1 - N3, J1(FM N1 to N3) : Width:30m</p> <p>Apron taxiway L(FM E9 to A14) Minimum separation distance from center line of apron taxiway on apron to object: 50.5m(166ft).</p> <p>Apron taxiway Z(FM spot 256 to spot 257) Minimum separation distance from center line of apron taxiway on apron to object: 55.0m(180ft).</p> <p>ACFT stand taxilane R(FM spot 5 to spot 8), R(FM spot 33 to spot 41), U, N4, Q, T(FM spot 80 to W6), T(FM spot 94 to spot 99) Minimum separation distance from center line of ACFT stand taxilane on apron to object: 42.5m(139ft).</p> <p>ACFT stand taxilane R(FM spot 1 to spot 4), R(FM spot 9 to spot 32) Minimum separation distance from center line of ACFT stand taxilane on apron to object: 40.0m(131ft).</p> <p>ACFT stand taxilane T(FM spot 82 to spot 93) Minimum separation distance from center line of ACFT stand taxilane on apron to object: 45.5m(149ft).</p> <p>ACFT stand taxilane S1, J4(BTN S1 and L) Minimum separation distance from center line of ACFT stand taxilane on apron to object: 50.5m(166ft).</p> <hr/> <p>Apron for rotor craft: Surface: Asphalt-concrete, Strength: PCN 11/F/B/Y/T</p> <p>ACFT stand taxilane P(the portion from rotor craft apron to 90m SW of the apron) Width: 18m, Surface: Asphalt-concrete, Strength: PCN 19/F/B/X/T</p>
<p>2</p>	<p>Taxiway width, surface and strength</p>	<p>TWY A2 - A13, E1 - E9, J1(BTN N1 and P), J4(BTN L and P), L(BTN J1 and E9), P(FM A1 to A14) Width: 30m, Surface: Asphalt-concrete, Strength: PCN 100/F/B/X/T</p> <p>TWY A1, A14 Width: 30m, Surface: Cement-concrete, Strength: PCN 130/R/C/X/T</p> <p>TWY P(BTN A1 and 94m NE of A1) Width: 18m, Surface: Asphalt-concrete, Strength: PCN 19/F/B/X/T</p> <p>TWY B5 - B10, J3, J4(BTN S1 and Y), S2, S4, S5, S6, Y Width: 30m, Surface: Asphalt-concrete, Strength: PCN 110/F/A/X/T</p> <p>TWY B1 Width: 37m, Surface: Cement-concrete, Strength: PCN 100/R/B/X/T</p> <p>TWY B3, B12 Width: 37m, Surface: Asphalt-concrete, Strength: PCN 110/F/A/X/T</p> <p>TWY B14 Width: 33.5m, Surface: Cement-concrete, Strength: PCN 100/R/B/X/T</p>

		TWY W6 - W9, Z(BTN J4 and W6) Width: 30m, Surface: Asphalt-concrete, Strength: PCN 130/F/A/X/T TWY Z(BTN J4 and spot 256) Width: 30m, Surface: Asphalt-concrete, Strength: PCN 75/F/A/X/T	
3	ACL and elevation	Not available	
4	VOR checkpoints	Not available	
5	INS checkpoints	Spot NR 1R : 342614.06N 1351453.50E 1 : 342614.03N 1351453.92E 1L : 342615.30N 1351454.42E 2 : 342615.98N 1351455.84E 3R : 342617.14N 1351458.09E 3 : 342617.10N 1351458.49E 3L : 342618.35N 1351459.00E 4 : 342619.03N 1351500.42E 5 : 342620.18N 1351503.10E 6 : 342621.71N 1351505.38E 7 : 342622.95N 1351506.78E 8 : 342621.60N 1351507.97E 9 : 342620.15N 1351509.70E 10 : 342619.00N 1351508.03E 11 : 342617.47N 1351505.75E 12 : 342615.94N 1351503.47E V1 : 342614.41N 1351501.18E 14 : 342612.88N 1351458.90E 15 : 342611.35N 1351456.61E 16 : 342609.56N 1351453.96E 17 : 342608.03N 1351451.68E 18 : 342606.50N 1351449.40E 19 : 342604.97N 1351447.11E 20 : 342603.45N 1351445.16E 21 : 342602.18N 1351443.27E 22 : 342600.92N 1351441.38E 23 : 342559.65N 1351439.18E 24 : 342558.11N 1351436.90E 25 : 342556.58N 1351434.61E 26 : 342554.80N 1351431.96E 27 : 342553.27N 1351429.68E 28 : 342551.74N 1351427.39E 29 : 342550.21N 1351425.11E 30 : 342548.67N 1351422.83E 31 : 342547.14N 1351420.55E 32 : 342545.61N 1351418.26E 33 : 342544.37N 1351416.87E 34 : 342545.71N 1351415.66E 35 : 342547.17N 1351413.95E 36 : 342548.32N 1351415.62E 37 : 342549.85N 1351417.90E 38 : 342551.38N 1351420.18E 39 : 342552.92N 1351422.46E 40 : 342554.45N 1351424.74E 41 : 342555.98N 1351427.03E 80 : 342625.18N 1351400.77E 81 : 342625.99N 1351400.00E 82 : 342626.60N 1351359.39E 83 : 342625.79N 1351358.62E 84 : 342624.95N 1351356.95E 85 : 342624.13N 1351356.15E 86 : 342623.30N 1351354.49E 87 : 342622.48N 1351353.69E 88 : 342621.65N 1351352.02E	Spot NR 89 : 342620.82N 1351351.22E 90 : 342619.99N 1351349.56E 91 : 342618.00N 1351346.59E 92 : 342616.78N 1351344.77E 93 : 342615.83N 1351342.67E 94 : 342614.82N 1351343.85E 95 : 342613.31N 1351345.33E 96 : 342611.80N 1351346.81E 97 : 342610.28N 1351348.29E 98 : 342608.75N 1351349.79E 99 : 342606.94N 1351351.55E 99E : 342607.07N 1351351.93E 99R : 342606.69N 1351351.77E 99L : 342607.71N 1351350.78E 101 : 342545.07N 1351404.87E 102 : 342543.18N 1351406.72E 103 : 342541.04N 1351408.81E 103R : 342541.70N 1351408.94E 103L : 342540.61N 1351410.01E 104 : 342539.15N 1351410.65E 105 : 342537.06N 1351412.70E 106 : 342536.13N 1351411.07E 107 : 342538.16N 1351409.09E 108 : 342539.69N 1351407.60E 109 : 342541.21N 1351406.11E 110 : 342542.74N 1351404.62E 111 : 342544.26N 1351403.13E 201 : 342541.12N 1351355.13E 202 : 342539.29N 1351356.91E 203 : 342537.46N 1351358.70E 204 : 342535.63N 1351400.49E 204R : 342536.25N 1351400.66E 204L : 342535.16N 1351401.73E 205 : 342533.80N 1351402.27E 206 : 342532.96N 1351404.67E 207 : 342531.48N 1351402.46E 208 : 342530.00N 1351400.26E 209 : 342528.52N 1351358.05E 210 : 342527.04N 1351355.84E 211 : 342525.55N 1351353.63E 212 : 342524.08N 1351351.43E 213 : 342522.60N 1351349.22E 214 : 342521.12N 1351347.02E 214L : 342521.07N 1351346.79E 215 : 342519.31N 1351344.11E 251 : 342557.71N 1351334.82E 252 : 342559.57N 1351333.01E 253 : 342601.40N 1351331.22E 254 : 342603.22N 1351329.43E 255 : 342605.08N 1351327.62E 256 : 342607.70N 1351325.86E 257 : 342605.91N 1351323.20E

		<p>M-2 : 342517.59N 1351341.76E M-3 : 342515.91N 1351340.17E M-4 : 342514.97N 1351337.86E M-5 : 342513.48N 1351335.64E M-6 : 342513.72N 1351331.63E M-7 : 342512.19N 1351329.35E M-8 : 342510.66N 1351327.07E M-9 : 342509.13N 1351324.79E</p> <p>601 : 342625.75N 1351531.71E 602 : 342625.10N 1351532.35E 603 : 342624.44N 1351532.99E 604 : 342623.79N 1351533.63E</p>	
6	Remarks	Nil	

RJBB AD 2.9 SURFACE MOVEMENT GUIDANCE AND CONTROL SYSTEM AND MARKINGS

1	Use of aircraft stand ID signs, TWY guide lines and Visual docking/ parking guidance system of aircraft stands	<p>ACFT stand ID sign: NR1R, 1, 1L, 2, 3R, 3, 3L, 4 - NR12, V1, NR14 -NR41 ACFT stand taxi lane: N1, N2, N3, N4, R, U, J1(FM N1 to N3), S1,J4(BTN L and S1), P(the portion from rotor craft apron to 90m SW of the apron) and T</p>
2	RWY and TWY markings and LGT	<p>RWY: RWY06R/24L, RWY06L/24R (Marking): RWY designation, RWY CL, RWY THR, Aiming point, TDZ, RWY side stripe, RWY middle point (LGT): REDL, RENL, RTHL, WBAR, RCLL, RTZL</p> <p>TWY: ALL TWY (Marking): TWY CL, TWY side stripe (LGT): TWY edge LGT, TWY CL LGT</p> <p>TWY: TWY A1 - A14, B1, B3, B5 - B10, B12 and B14 (Marking): RWY HLDG PSN, Mandatory instruction, Enhanced TWY CL (LGT): RWY guard LGT</p> <p>TWY: TWY P, L, N1, E9, U, R, A14, J1, J4, S1, S4, S6, T, B7 and B8 (Marking) Surface painted location sign and surface painted direction sign</p>
3	Stop bars	<p>Stop bar LGT : A1 - A14, B1, B3, B5 - B10, B12 and B14 (The locations of stop bar LGT and runway guard LGT are 90m off the runway 06R/24L center line and 107.5m off the runway 06L/24R center line.) Stop bar LGT Operations</p> <ol style="list-style-type: none"> 1) Stop bar LGT are installed at each taxi holding position associated with Runway 06R/24L, 06L/24R 2) Stop bar LGT will be operated when the visibility or the lowest RVR of the Runway 06R/24L and/or 06L/24R is at or less than 600m 3) Stop bar LGT on taxiways A1, A2, A13, A14, B1 and B14 are controlled individually by ATC 4) During the period stop bar LGT operated, taxiways A3 through A12, B3, B5 through B10 and B12 are not available for departure aircraft
4	Remarks	<p>(Marking): Overrun area, ACFT stand marking(lead-in lines, turning lines), ACFT stand ID sign, apron safety lines (wing tip line, equipment limit line), ACFT PRKG PSN, Apron TWY CL, ACFT stand taxi lane, stop line and Vehicle traffic lines Stopline/yellow, broken line Vehicle traffic line/white line (LGT): Taxiing guidance sign, Apron flood LGT</p>

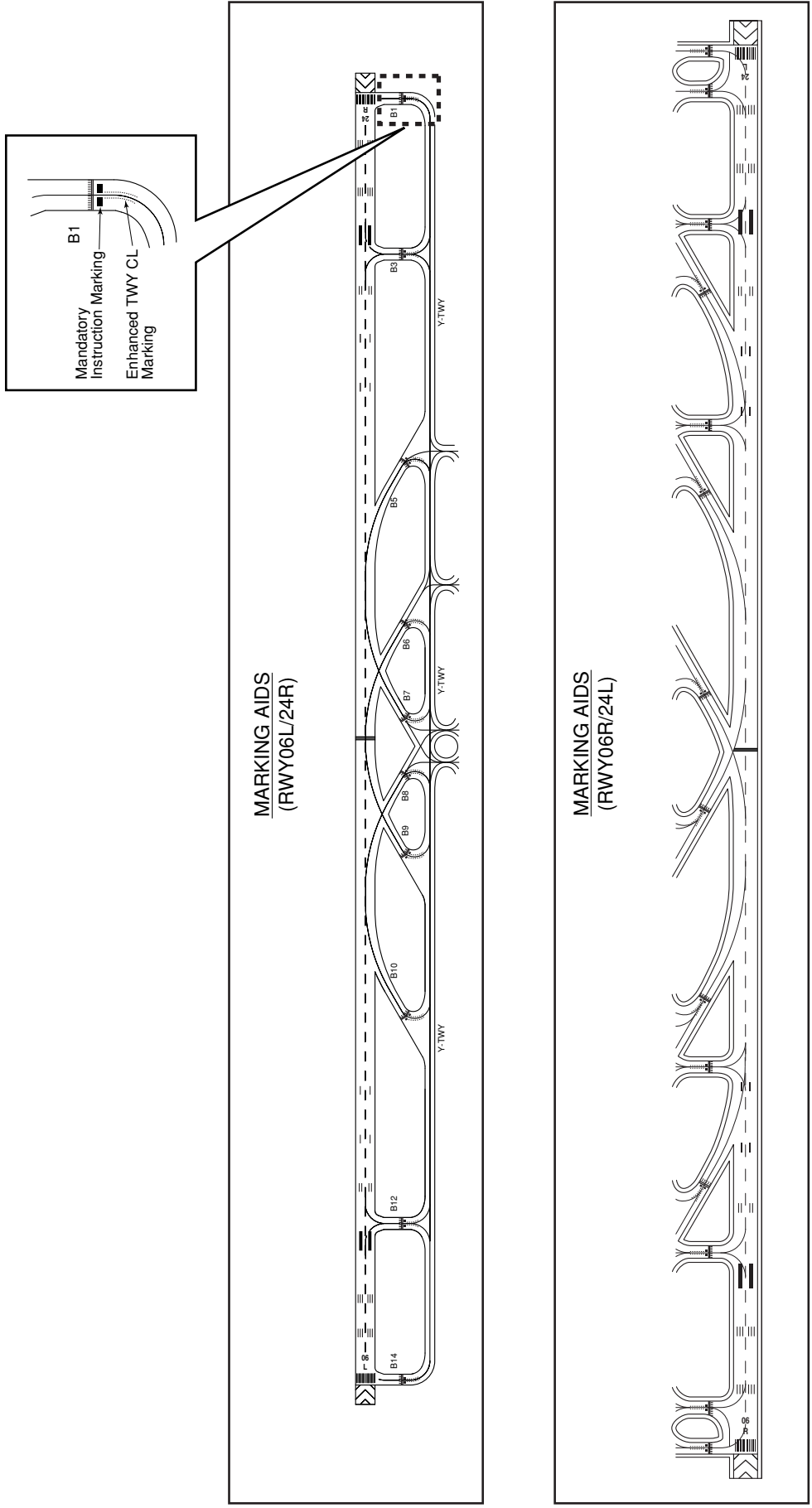

Type of Surface Painted Markings

1. Type of Surface Painted Markings

- Surface Painted Direction Sign
This type of marking at a taxiway intersection indicates the designation and direction of taxiway leading out of an intersection. Black inscriptions with an arrow with a yellow background.
- Surface Painted Location Sign
This type of marking indicates the designation of the taxiway on which the aircraft is located. Yellow inscriptions with a black background and yellow frame.

2. On each of the Taxiways P, L, N1, E9, U, R, A14, J1, J4, S1, S4, S6, T, B7 and B8, surface painted markings are provided. (refer attached drawing.)

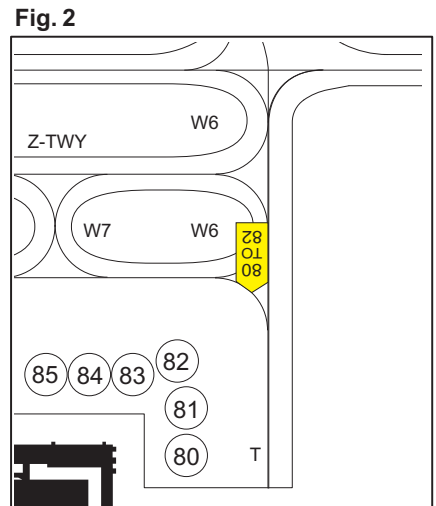
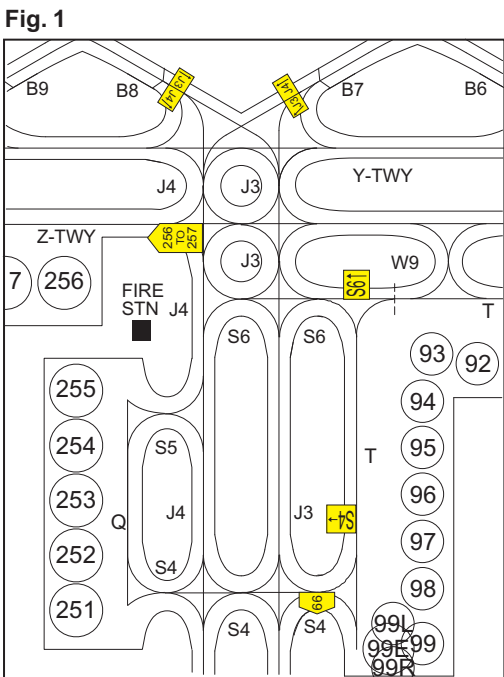
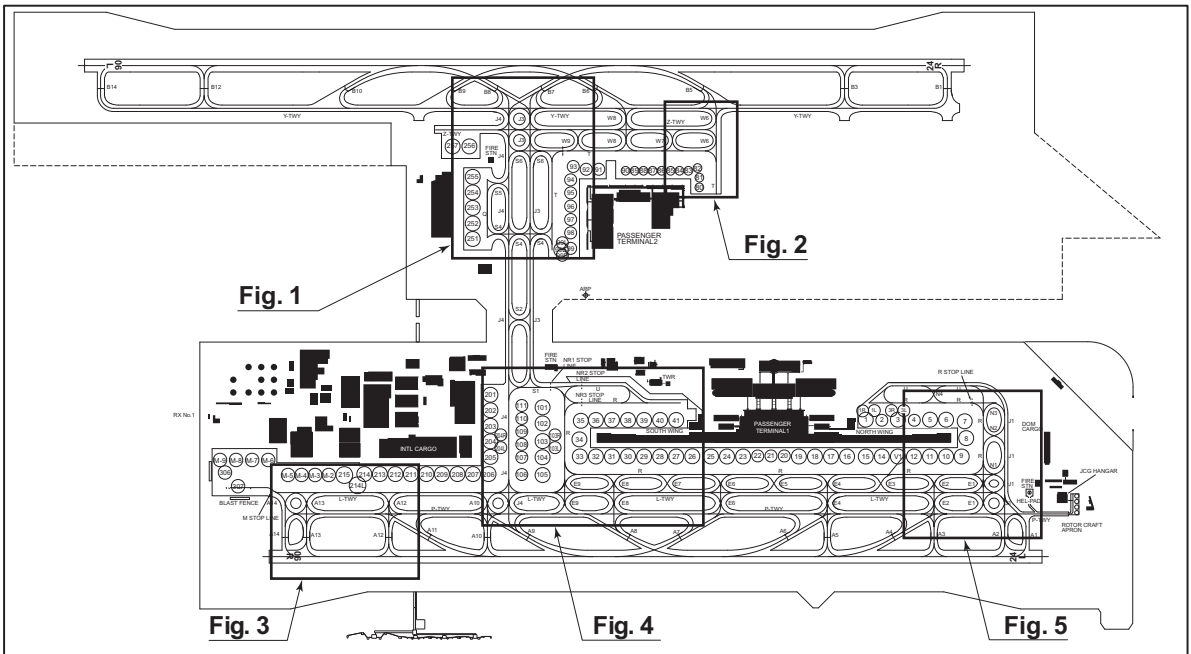

Fig. 3

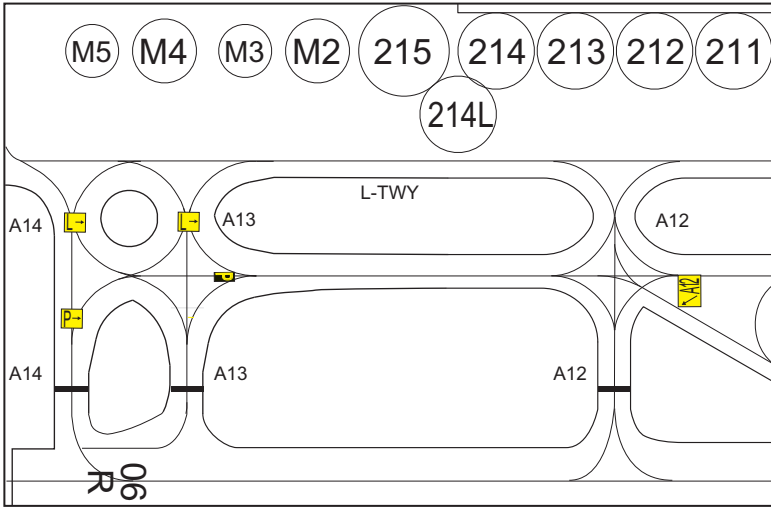

Fig. 4

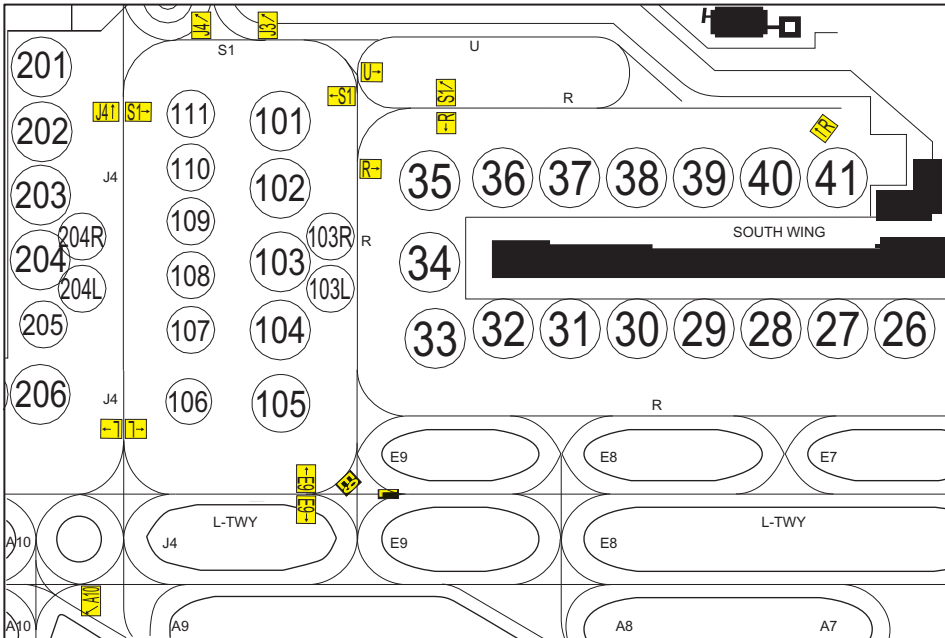
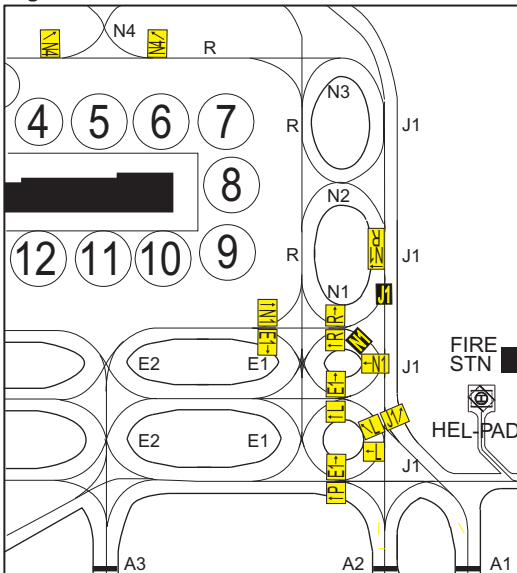

Fig. 5



RJBB AD 2.10 AERODROME OBSTACLES

In Area2 See Obstacle data



In Area3 To be developed

RJBB AD 2.11 METEOROLOGICAL INFORMATION PROVIDED

1	Associated MET Office	KANSAI
2	Hours of service MET Office outside hours	H24
3	Office responsible for TAF preparation Periods of validity	KANSAI 30 Hours
4	Trend forecast Interval of issuance	TREND 30min
5	Briefing/ consultation provided	P, Ja, En
6	Flight documentation Language(s) used	C En
7	Charts and other information available for briefing or consultation	S ₆ , U ₈₅ , U ₇ , U ₅ , U ₃ , U ₂₅ , U ₂ /T _r , P _S , P ₅ , P ₃ , P ₂₅ , P _{SWE} , P _{SWF} , P _{SWG} , P _{SWI} , P _{SWM} , P _{SW} (domestic), E, C, W _E , W _F , W _G , W _I , W, N
8	Supplementary equipment available for providing information	Doppler Radar and Lidar for Airport Weather (See attached chart)
9	ATS units provided with information	TWR, APP, ATIS
10	Additional information(limitation of service, etc.)	Nil

RJBB AD 2.12 RUNWAY PHYSICAL CHARACTERISTICS

Designations RWY NR	TRUE BRG	Dimensions of RWY(M)	Strength(PCN) and surface of RWY	THR coordinates THR geoid undulation	THR elevation and highest elevation of TDZ of precision APP RWY
1	2	3	4	5	6
06R	051.00°	3500x60	PCN 110/F/B/X/T Asphalt Concrete	342502.56N 1351345.40E 122.8ft	THR ELEV:5.0ft TDZ ELEV:5.8ft
24L	231.00°	3500x60	PCN 110/F/B/X/T Asphalt Concrete	342614.04N 1351531.92E 123.0ft	THR ELEV:12.3ft TDZ ELEV:12.3ft
06L	050.98°	4000x60	PCN 110/F/A/X/T Asphalt Concrete	342542.86N 1351222.33E 122.5ft	THR ELEV:9.2ft TDZ ELEV:17.4ft
24R	230.98°	4000x60	PCN 110/F/A/X/T Asphalt Concrete	342704.58N 1351424.08E 122.6ft	THR ELEV:15.6ft TDZ ELEV:17.9ft

Slope of RWY	Strip Dimensions(M)	RESA (Overrun) Dimensions(M)	Remarks
7	10	11	14
See below figure	3620x300	240 x 300	RWY grooving: 3500mx40m
See below figure	3620x300	240 x 300	RWY grooving: 3500mx40m
See below figure	4120x300	240 x 300	First 96.5m of RWY06L Surface: Cement-concrete Strength: PCN 100/R/B/X/T RWY grooving: 3803.5mx40m
See below figure	4120x300	240 x 300	First 100m of RWY 24R Surface: Cement-concrete Strength: PCN 100/R/B/X/T RWY grooving: 3803.5mx40m

RWY 06R

RWY 24L

RWY 06L

RWY 24R

RJBB AD 2.13 DECLARED DISTANCES

RWY Designator	TORA (m)	TODA (m)	ASDA (m)	LDA (m)	Remarks
1	2	3	4	5	6
06R	3500	3500	3500	3500	Nil
24L	3500	3500	3500	3500	Nil
06L	4000	4000	4000	4000	Nil
24R	4000	4000	4000	4000	Nil

RJBB AD 2.14 APPROACH AND RUNWAY LIGHTING

RWY Designator	APCH LGT type LEN INTST	RTHL Color WBAR	PAPI (VASIS) Angle DIST FM THR MEHT	RTZL LEN	RCLL LEN Spacing Color INTST	REDL LEN Spacing Color INTST	RENL Color WBAR	STWL LEN Color
1	2	3	4	5	6	7	8	9
06R	PALS (CAT II) 900m LIH	Green Green	PAPI 3.0°/LEFT 416m 66ft	900m	3,500m 15m Coded color (white/Red) LIH	3,500m 60m Coded color (white/Yellow) LIH	Red	Nil (*1)
24L	PALS (CAT II) 900m LIH	Green Green	PAPI 3.0°/LEFT 474m 67ft	900m	3,500m 15m Coded color (white/Red) LIH	3,500m 60m Coded color (white/Yellow) LIH	Red	Nil (*1)
06L	PALS (CAT II) 900m LIH	Green Green	PAPI 3.0°/LEFT 383m 66ft	900m	4,000m 15m Coded color (white/Red) LIH	4,000m 60m Coded color (white/Yellow) LIH	Red	Nil (*1)
24R	PALS (CAT II) 900m LIH	Green Green	PAPI 3.0°/LEFT 421m 67ft	900m	4,000m 15m Coded color (white/Red) LIH	4,000m 60m Coded color (white/Yellow) LIH	Red	Nil (*1)
Remarks								
10								
Overrun area edge LGT(LEN:60m Color:Red) (*1)								

**LIGHTING AIDS
(RWY06L/24R)**



**LIGHTING AIDS
(RWY06R/24L)**

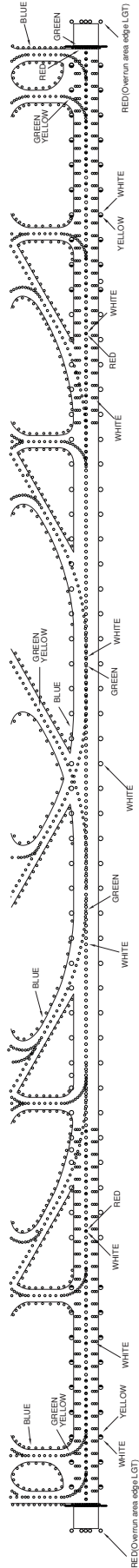

RJBB AD 2.15 OTHER LIGHTING, SECONDARY POWER SUPPLY

1	ABN/IBN location, characteristics and hours of operation	ABN: 342602N/1351319E, White/Green EV4.3sec, HO
2	LDI location and LGT Anemometer location and LGT	LDI: Nil Anemometer: RWY06R: 420m from RWY06R THR, LGTD RWY24L: 460m from RWY24L THR, LGTD RWY06L: 449m from RWY06L THR, LGTD RWY24R: 499m from RWY24R THR, LGTD
3	TWY edge and center line lighting	TWY edge and center line lights installed. see AD2.9
4	Secondary power supply/ switch-over time	Within 1 sec: PALS, PAPI, REDL, RENL, RTHL, WBAR, RCLL, RTZL, Overrun area edge LGT, Stop bar LGT, RWY guard LGT Within 15 sec: Other lights
5	Remarks	WDI LGT

RJBB AD 2.16 HELICOPTER LANDING AREA

NIL

RJBB AD 2.17 ATS AIRSPACE

Designation and lateral limits		Vertical limits (ft)	Airspace classification	ATS unit call sign Language	Remarks
1		2	3	4	6
KANSAI CTR	Area within a radius of 5NM of KANSAI INTERNATIONAL ARP(3426N/13514E)	----- 3000	D	KANSAI TWR En	
KANSAI PCA	1.The airspace bounded by the lines connecting the following points. a) (1)343824N1351215E, (2)343815N1351930E, (23)343306N1351206E, thence to point(1). The line connecting point(2) to point(23) is the arc with a radius of 5NM from KOBE ARP.	5000 ----- 2500 (EXC 2500)	C	KANSAI APP	See Attachment
	2.The airspace bounded by the lines connecting the following points. a) (2)343815N1351930E, (3)343809N1352433E, (4)343520N1352558E, (5)343408N1352524E, (21)343415N1352014E, (20)343313N1351945E, (19)343044N1351603E, (22)343047N1351201E, (23)343306N1351206E, thence to point(2). The line connecting point(19) to point(22) is the arc with a radius of 5NM from KANSAI INTERNATIONAL ARP. The line connecting point(23) to point(2) is the arc with a radius of 5NM from KOBE ARP	5000 ----- 1500		KANSAI RADAR KANSAI DEP En	

Designation and lateral limits		Vertical limits (ft)	Airspace classification	ATS unit call sign Language	Remarks
1		2	3	4	6
KANSAI PCA	3.The airspace bounded by the lines connecting the following points. a) (5)343408N1352524E, (6)343147N1352417E, (20)343313N1351945E, (21)343415N1352014E, thence to point(5).	4000 ----- 1000	C	KANSAI APP KANSAI RADAR KANSAI DEP En	See Attachment
	4.The airspace bounded by the lines connecting the following points. a) (6)343147N1352417E, (7)342829N1352245E, (8)342637N1351959E, (19)343044N1351603E, (20)343313N1351945E,thence to point(6). The line connecting point(8) to point(19) is the arc with a radius of 5NM from KANSAI INTERNATIONAL ARP.	3000 ----- 700			
	5.The airspace bounded by the lines connecting the following points. a) (9)342119N1351202E, (10)341943N1350938E, (17)342347N1350538E, (18)342520N1350758E, thence to point(9). The line connecting point(18) to point(9) is the arc with a radius of 5NM from KANSAI INTERNATIONAL ARP.	4000 ----- 700			
	6.The airspace bounded by the lines connecting the following points. a) (10)341943N1350938E, (11)341827N1350745E, (16)342231N1350345E, (17)342347N1350538E, thence to point(10).	5000 ----- 1000			
	7.The airspace bounded by the lines connecting the following points. a) (11)341827N1350745E, (12)341653N1350524E, (15)342057N1350125E, (16)342231N1350345E, thence to point(11).	7000 ----- 1500			
	8.The airspace bounded by the lines connecting the following points. a) (12)341653N1350524E, (13)341449N1350219E, (14)341853N1345820E, (15)342057N1350125E, thence to point(12).	7000 ----- 2000			
KANSAI ACA	See Attachment		E	KANSAI APP KANSAI RADAR KANSAI DEP En	
KANSAI TCA	See Attachment			KANSAI TCA En	

Kansai Positive Control Area

NAME	LATERAL LIMITS	UPPER LIMIT (AMSL) ----- LOWER LIMIT (AMSL) M(ft)	UNIT PROVIDING SERVICE	REMARKS
1	2	3	4	5
Kansai	The area shown on the below attachment.		Primary: Kansai APP Kansai Radar 125.5-120.25 258.3 Secondary: Kansai Tower 118.2-126.2 236.8	当該空域を飛行しようとする航空機は関西アプローチ(レーダー)又は、関西タワーに連絡し、コールサイン、現在位置、高度及び意図を通報し指示を受けること。 Pilot of aircraft operating in this area shall contact KANSAI APP(RADAR) or KANSAI TWR for ATC instructions giving informations on aircraft identifications, position, altitude and pilot's intentions.

関西特別管制区
Kansai Positive Control Area

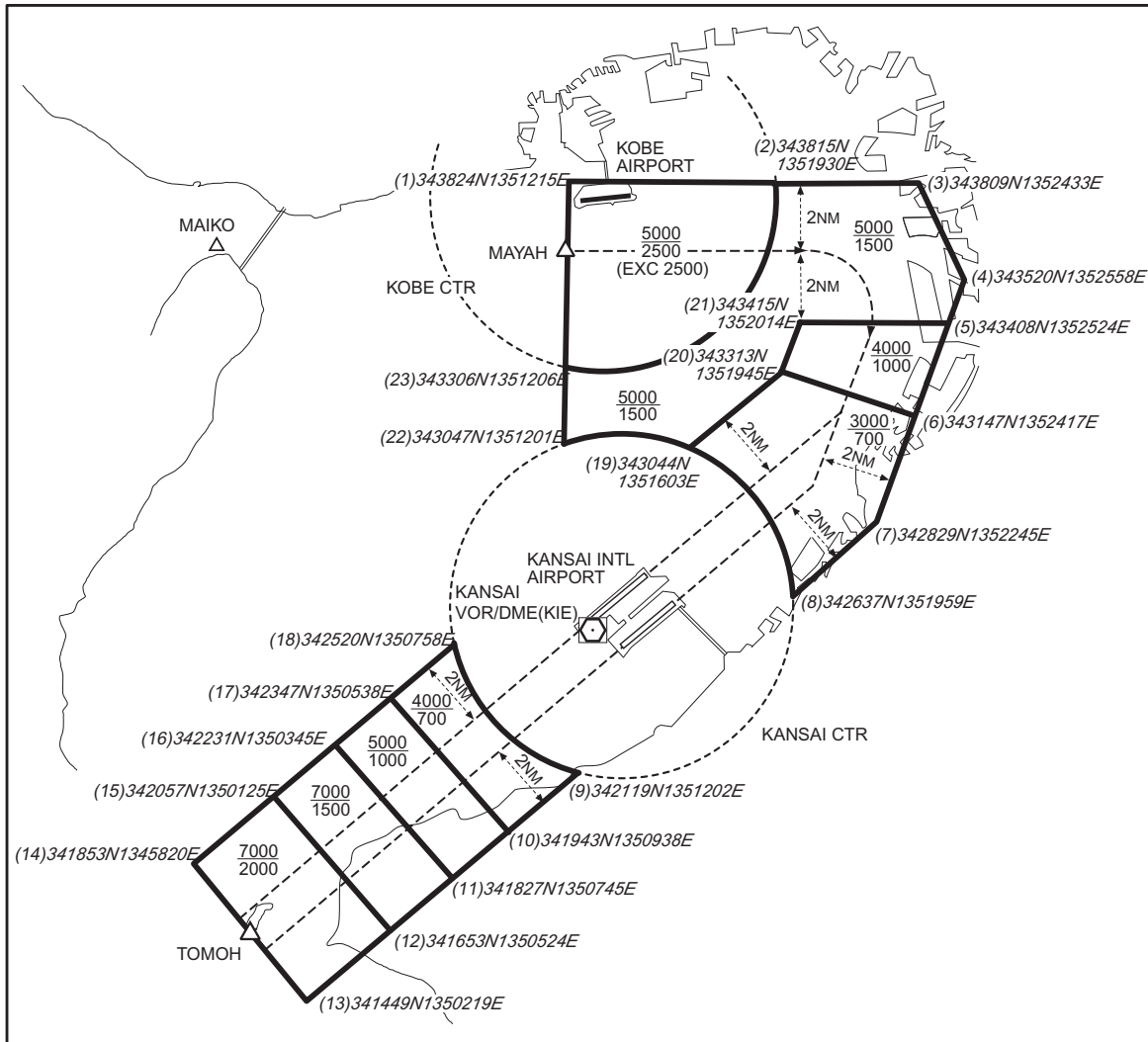

関西進入管制区
Kansai Approach Control Area

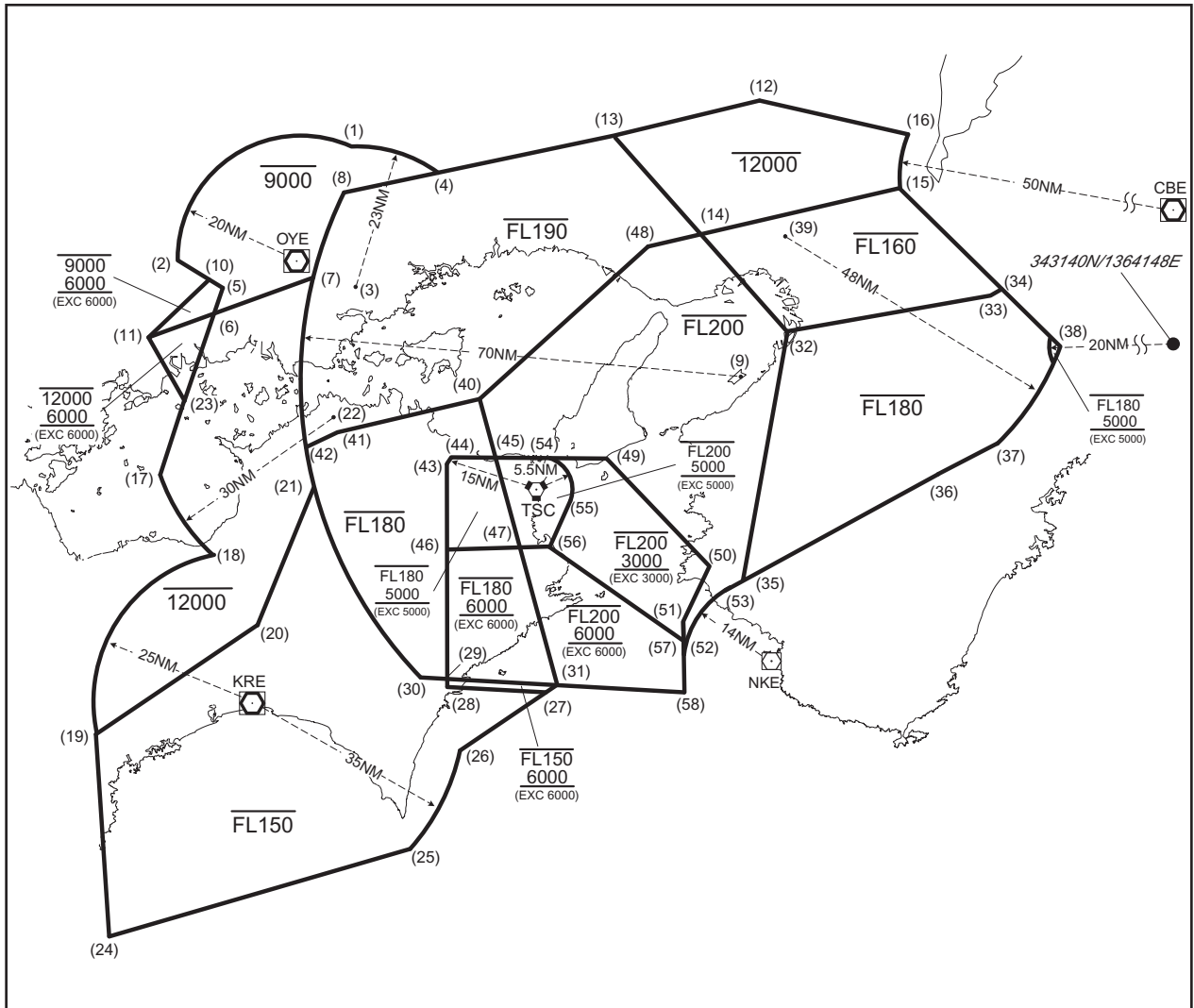

Point list

(1) 350315N/1340005E	(19) 332732N/1331127E	(37) 341457N/1360647E	(55) 340527N/1344232E
(2) 344441N/1332547E	(20) 334532N/1334215E	(38) 343100N/1361905E	(56) 335837N/1343856E
(3) 344017N/1340054E	(21) 340720N/1335327E	(39) 344820N/1352413E	(57) 334323N/1350500E
(4) 345937N/1341603E	(22) 341935N/1335712E	(40) 342232N/1342524E	(58) 333500N/1350500E
(5) 344000N/1333500E	(23) 342147N/1332738E	(41) 341701N/1335730E	
(6) 343603N/1333324E	(24) 325459N/1331440E	(42) 341438N/1335129E	
(7) 344157N/1335227E	(25) 330932N/1341223E	(43) 341136N/1341900E	
(8) 345603N/1335824E	(26) 332535N/1342155E	(44) 341300N/1341932E	
(9) 342548N/1351506E	(27) 333446N/1343838E	(45) 341300N/1342835E	
(10) 344020N/1333422E	(28) 333545N/1341900E	(46) 335801N/1341900E	
(11) 343206N/1332020E	(29) 333702N/1341900E	(47) 335827N/1343323E	
(12) 351108N/1351858E	(30) 333714N/1341422E	(48) 344713N/1345844E	
(13) 350546N/1344808E	(31) 333607N/1344043E	(49) 341300N/1345028E	
(14) 344856N/1350739E	(32) 343325N/1352529E	(50) 335551N/1350941E	
(15) 345633N/1354735E	(33) 343914N/1360525E	(51) 334636N/1350500E	
(16) 350505N/1354931E	(34) 344019N/1360739E	(52) 334204N/1350500E	
(17) 340944N/1332257E	(35) 335310N/1351614E	(53) 335203N/1351343E	
(18) 335647N/1333342E	(36) 340913N/1355246E	(54) 341300N/1343838E	

関西ターミナルコントロールエリア
Kansai Terminal Control Area

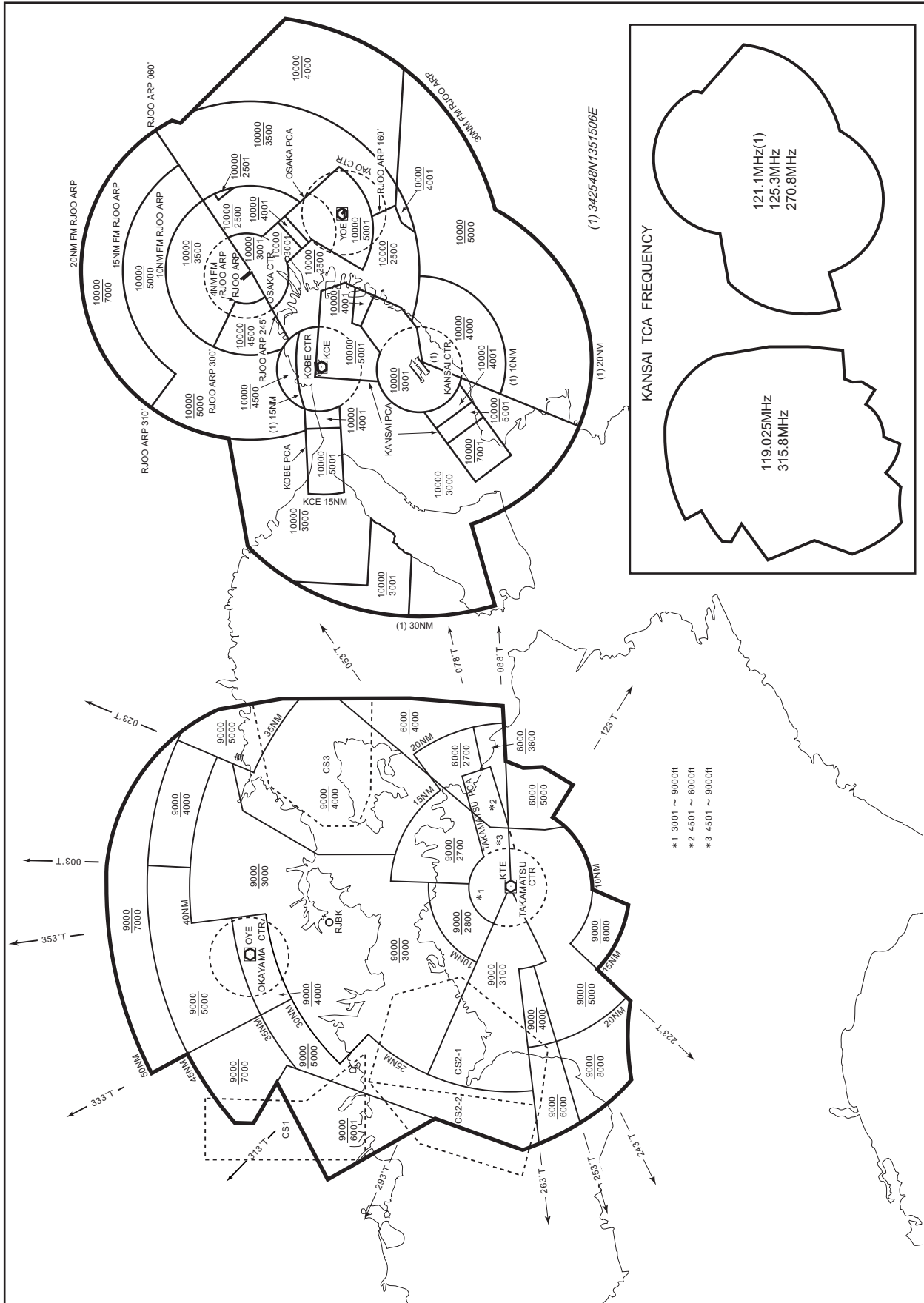

RJBB AD 2.18 ATS COMMUNICATION FACILITIES

Service designation	Call sign	Frequency	Hours of operation	Remarks
1	2	3	4	5
APP/ASR	Kansai Approach/ Kansai Radar	120.25MHz 120.45MHz 125.5MHz 124.7MHz 121.15MHz 120.85MHz 125.0MHz 119.75MHz 124.8MHz 121.2MHz 120.4MHz 258.3MHz 261.2MHz 121.5MHz(E) 243.0MHz(E)	H24	(1)primary
DEP	Kansai Departure	119.2MHz 120.65MHz 119.5MHz 119.75MHz 124.8MHz 125.0MHz 120.4MHz 121.2MHz 261.2MHz 121.5MHz(E) 243.0MHz(E)	H24	
TCA	Kansai TCA	121.1MHz(1) 125.3MHz 270.8MHz 119.025MHz 315.8MHz	2300 - 1030	
TWR	Kansai Tower	118.2MHz 118.05MHz 126.2MHz 236.8MHz 121.5MHz(E) 243.0MHz(E)	H24	
GND	Kansai Ground	121.6MHz 121.65MHz 118.575MHz 126.2MHz	H24	
DLVRY	Kansai Delivery	121.9MHz 126.2MHz	H24	
ATIS	Kansai INTL Airport	127.85MHz	H24	

RJBB AD 2.19 RADIO NAVIGATION AND LANDING AIDS

Type of aid (VOR declination)	ID	Frequency	Hours of operation	Position of transmitting antenna coordinates	Elevation of DME transmitting antenna	Remarks
1	2	3	4	5	6	7
VOR (8°W/2020)	KIE	111.6MHz	H24	342532.66N/1351227.83E		VOR unusable: 180°-190° beyond 35nm BLW 4000ft.
DME	KIE	1014MHz (CH-53X)	H24	342532.66N/1351227.83E	37.9ft	DME unusable: 350°-030° beyond 30nm BLW 6000ft. 160°-170° beyond 35nm BLW 7000ft. 170°-180° beyond 30nm BLW 7000ft. 180°-190° beyond 20nm BLW 4000ft. 190°-200° beyond 30nm BLW 4000ft. 210°-220° beyond 30nm BLW 4000ft. 290°-310° beyond 30nm BLW 4000ft. 330°-350° beyond 35nm BLW 6000ft.
ILS-LOC 06R	IKD	108.1MHz	H24	342620.66N/1351541.80E		LOC: 325m(1066ft) away FM RWY24L THR, BRG(MAG) 058.88°
ILS-GP 06R	-	334.7MHz	H24	342505.97N/1351357.92E		GP: 315m(1033FT) inside FM RWY06R THR, 120m(394ft) SE of RCL. HGT of ILS reference datum 16.5m(54ft) GP angle 3.0°
ILS-DME 06R	IKD	979MHz (CH-18X)	H24	342505.95N/1351358.29E	25ft	DME: 322m(1056ft) inside FM RWY06R THR, 127m(417ft) SE of RCL.
IM 06R	-	75MHz	H24	342457.31N/1351337.58E		0.14NM FM RWY06R THR.
ILS-LOC 24L	IKN	110.7MHz	H24	342455.89N/1351335.52E		LOC: 325m(1066ft) away FM RWY06R THR, BRG (MAG) 238°
ILS-GP 24L	-	330.2MHz	H24	342603.59N/1351524.16E		GP: 356m(1168ft) inside FM RWY24L THR, 126m(413ft) SE of RCL. HGT of ILS reference datum 16.9m(55ft). GP angle 3.0°
ILS-DME 24L	IKN	1005MHz (CH-44X)	H24	342603.33N/1351524.41E	28ft	DME: 356m(1168ft) inside FM RWY24L THR, 136m(446ft) SE of RCL.
IM 24L	-	75MHz	H24	342619.29N/1351539.74E		0.14NM FM RWY24L THR.
ILS-LOC 06L	IKJ	108.7MHz	H24	342711.12N/1351433.82E		LOC: 320m(1050ft) away FM RWY24R THR, BRG(MAG) 058.78°
ILS-GP 06L	-	330.5MHz	H24	342551.83N/1351228.53E		GP: 297m(974ft) inside FM RWY06L THR, 116m(381ft) NW of RCL. HGT of ILS reference datum 16.5m(54ft). GP angle 3.0°

Type of aid (VOR declination)	ID	Frequency	Hours of operation	Position of transmitting antenna coordinates	Elevation of DME transmitting antenna	Remarks
1	2	3	4	5	6	7
ILS-DME 06L	IKJ	985MHz (CH-24X)	H24	342552.21N/1351228.16E	35ft	DME: 297m(974ft) inside FM RWY06L THR, 130m(427ft) NW of RCL.
IM 06L	-	75MHz	H24	342537.61N/1351214.51E		0.14NM FM RWY06L THR.
ILS-LOC 24R	IKW	108.5MHz	H24	342536.32N/1351212.59E		LOC: 320m(1050ft) away FM RWY06L THR, BRG(MAG) 238.94°
ILS-GP 24R	-	329.9MHz	H24	342701.04N/1351411.61E		GP: 316m(1037ft) inside FM RWY24R THR, 116m(381ft) NW of RCL. HGT of ILS Ref datum 16.5m(54ft). GP angle 3.0°
ILS-DME 24R	IKW	983MHz (CH-22X)	H24	342700.89N/1351411.76E	35ft	DME: 316m(1037ft) inside FM RWY24R THR, 110m(361ft) NW of RCL.
IM 24R	-	75MHz	H24	342709.83N/1351431.90E		0.14NM FM RWY 24R THR.
MSAS		1575.42MHz	H24			Transmitting antennas are satellite based

RJBB / KANSAI INTL

ILS

ILS FOR RWY 06R

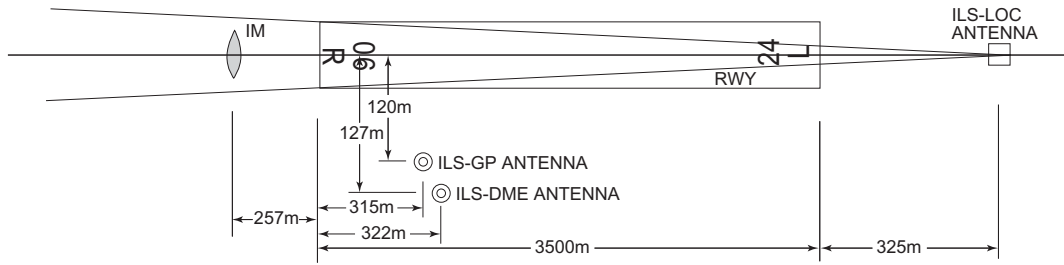

- REMARKS : 1. LOC beam BRG(MAG) 058.88°
 2. HGT of ILS REF datum 16.5m (54ft)
 3. GP Angle 3.0°
 4. ELEV of ILS-DME 7.5m (25ft)

ILS FOR RWY 24L

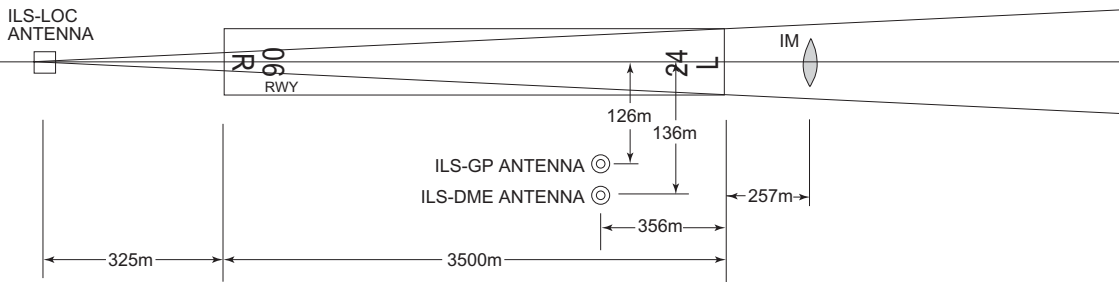

- REMARKS : 1. LOC beam BRG(MAG) 238°
 2. HGT of ILS REF datum 16.9m (55ft)
 3. GP Angle 3.0°
 4. ELEV of ILS-DME 8.5m (28ft)

ILS FOR RWY 06L

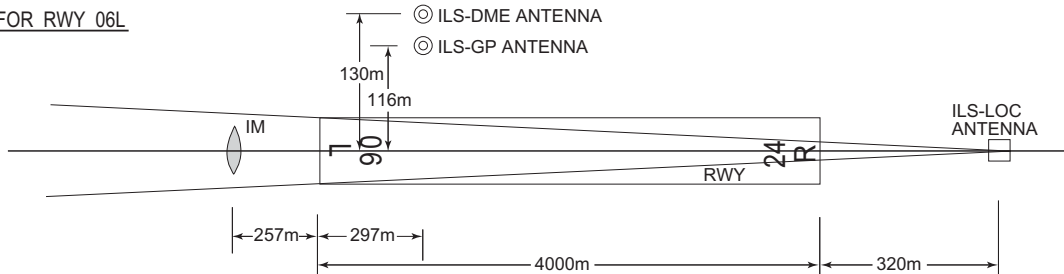

- REMARKS : 1. LOC beam BRG(MAG) 058.78°
 2. HGT of ILS REF datum 16.5m (54ft)
 3. GP Angle 3.0°
 4. ELEV of ILS-DME 10.5m (35ft)

ILS FOR RWY 24R

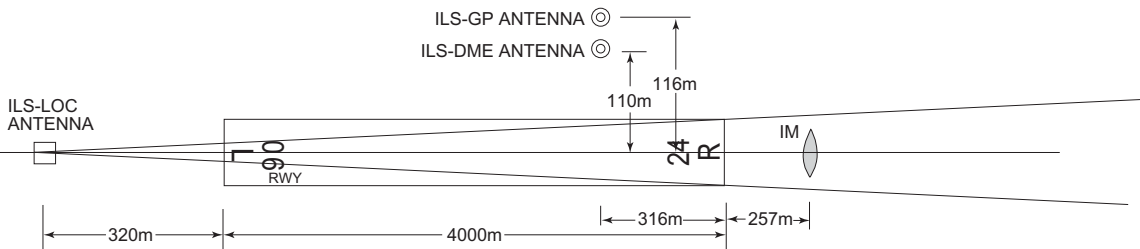

- REMARKS : 1. LOC beam BRG(MAG) 238.94°
 2. HGT of ILS REF datum 16.5m (54ft)
 3. GP Angle 3.0°
 4. ELEV of ILS-DME 10.6m (35ft)

RJBB AD 2.20 LOCAL TRAFFIC REGULATIONS

1. Airport regulations

<p>1.1 この空港の利用に関して</p> <p>1.1.1 定期便または緊急事態以外の航空機の運航者は、当空港の使用について、空港管理者の許可を得ること。</p> <p>1.1.2 到着機は、RNAV1 による飛行を推奨する。</p> <p>1.1.3 RNAV1 非対応の到着機は、1400UTC から 2330UTC の間の就航を禁止する。</p> <p>1.1.4 「ILS Y or LOC Y RWY24L」は、以下の場合に限り使用される。 (1) 緊急状態にある航空機 (2) RNAV1 非適合機であって； (a) 捜索・救難に従事する航空機 (b) 人道上の支援に従事する航空機 注：上記 (a) 及び (b) に該当する航空機を運航する場合は、事前に空港管理者と調整すること。</p>	<p>1.1 On use of this airport</p> <p>1.1.1 On use of this airport, aircraft operator is required to obtain the prior permission of the Airport Administrator, except scheduled flights or in an emergency.</p> <p>1.1.2 Arriving aircraft is requested to have approvals for RNAV1.</p> <p>1.1.3 Arriving aircraft without approvals of RNAV1 is prohibited from operating between 1400UTC and 2330 UTC.</p> <p>1.1.4 "ILS Y or LOC Y RWY24L" is used only for the following cases: (1) Aircraft encountered with an emergency. (2) RNAV1 non-approved aircraft and ; (a) aircraft operating for the purpose of by a search and rescue. (b) aircraft operating for the support in the humanity. NOTE: For the aircraft operation correspond to any of the item (a) or (b), coordination is required beforehand with airport administrator.</p>
---	--

<p>1.2 管制方式</p> <p>1.2.1 出発機 出発機は次に掲げる方式に従うこと。</p> <p>(1) 管制承認 出発機はエンジン始動 5 分前の通報に合わせて、次に掲げる項目を関西デリバリーに通報すること a) 航空機呼出符号 b) 目的地 c) 要求高度(代替要求高度がある場合は、当該高度) d) 駐機位置 (スポット番号) e) 代替飛行経路がある場合は当該飛行経路</p> <p>(2) 地上走行 R、T、U 及び S1 タクシーウェイを走行する航空機は、R、T1、T2 及び NR1 ~ 4 ストップラインでの停止を指示されることがある。</p> <p>(3) インターセクション・ディパーチャー a) AD1.1.6.3.2.2(2)に記載されている出発機間の管制間隔は、誘導路 A2 または A13 から出発する航空機には適用されない。AD1.1.6.3.2.2(2)における間隔を必要とする航空機は、その旨を関西グランド / タワーに適宜通報すること。</p>	<p>1.2 ATC Procedures</p> <p>1.2.1 Departing aircraft Departing aircraft shall comply with the following procedures.</p> <p>(1) ATC clearance Advise KANSAI DELIVERY 5 minutes prior to starting engines with the following items. a) call sign b) destination c) proposed flight level/altitude (alternative flight levels/altitudes, if any) d) parking position (spot number) e) alternative flight routes, if any</p> <p>(2) Taxi Aircraft taxing on R, T, U and S1 taxilanes may be instructed to hold at the R, T1, T2 and NR1 - 4 stoplines shown in RJBB AD2.24 Taxing guide lines and parking areas.</p> <p>(3) Intersection departure a) Separation for departure as in AD1.1.6.3.2.2(2) will not be applied to aircraft departing from TWY A2 or A13. Aircraft requiring separation in AD1.1.6.3.2.2(2) shall advise "KANSAI GROUND/TOWER" accordingly.</p>
---	--

b) 各インターセクションディパーチャーによる滑走路残距離は次のとおり			b) The remaining runway length for intersection departures are as follows.		
RWY	TWY	Remaining RWY length*	RWY	TWY	Remaining RWY length*
06R	A13	3,320m (10,900ft)	06L	B12	3440m (11,280ft)
	A12	2,940m (9,640ft)		B10	2500m (8,200ft)
	A11	2,500m (8,220ft)		B9	2000m (6,560ft)
	A10	2,470m (8,120ft)		B7	1570m (5,180ft)
	A9	2,040m (6,700ft)			
	A8	1,570m (5,160ft)			
24L	A2	3,320m (10,900ft)	24R	B3	3440m (11,280ft)
	A3	2,990m (9,820ft)		B5	2500m (8,200ft)
	A4	2,560m (8,390ft)		B6	2000m (6,560ft)
	A5	2,490m (8,180ft)		B8	1530m (5,020ft)
	A6	2,060m (6,750ft)			
	A7	1,560m (5,110ft)			

*Rounded down to the nearest 10m(10ft) from the measurement between the point where TWY CL meets RWY CL and RWY THR.

1.2.2 CDO (Continuous Descent Operation)	1.2.2 CDO (Continuous Descent Operation)
<p>関西国際空港へのCDOは次に掲げる方式に従うこと。</p> <p>(1) 適用時間 関西国際空港到着予定時刻が2300JSTから0700JSTの間</p> <p>(2) 対象経路 A. 滑走路24運用時 (a) KARINからBECKY DELTA ARRIVALを経由する経路。 (b) RANDYからBERTH DELTA ARRIVALを経由する経路。 (c) EVERTからCANDY DELTA ARRIVALを経由する経路。 B. 滑走路06運用時 (a) KARINからBECKY ALFA ARRIVAL又はBECKY BRAVO ARRIVALを経由する経路。 (b) RANDYからBERTH ALFA ARRIVAL又はBERTH BRAVO ARRIVALを経由する経路。 (c) EVERTからCANDY ALFA ARRIVAL又はCANDY BRAVO ARRIVALを経由する経路。</p> <p>(3) 実施方式 A. CDOの要求及び承認 (a) 航空機からのCDOの要求及び管制機関からの承認は、次表のCDO経路名を用いて行う。CDO経路には高度制限が付加されていることに留意すること。 (b) 使用滑走路が変更になった場合、CDOが再承認されるか、中止が指示される。 B. CDOの要求時期 航空機は、降下開始点に到達する時刻の10分前までに、KARIN、RANDY又はEVERT通過予定時刻及び降下開始点を付して、管制機関に対してCDOの要求を行うこと。ただし、佐賀空港から出発する航空機については、降下開始点の5分前又はRANDYの通過予定時刻の5分前までのいずれか早い時刻までに要求を行うこと。</p>	<p>Pilot shall comply following procedures when conduct CDO at Kansai INTL AP.</p> <p>(1) Applicable time ETA at Kansai INTL AP between 1400UTC and 2200UTC.</p> <p>(2) Routes applicable for CDO A. When RWY24 in use (a) Arrival routes via KARIN and join BECKY DELTA ARRIVAL. (b) Arrival routes via RANDY and join BERTH DELTA ARRIVAL. (c) Arrival routes via EVERT and join CANDY DELTA ARRIVAL. B. When RWY06 in use (a) Arrival routes via KARIN and join BECKY ALFA ARRIVAL or BECKY BRAVO ARRIVAL. (b) Arrival routes via RANDY and join BERTH ALFA ARRIVAL or BERTH BRAVO ARRIVAL. (c) Arrival routes via EVERT and join CANDY ALFA ARRIVAL or CANDY BRAVO ARRIVAL.</p> <p>(3) Procedures A. Request and clearance of CDO (a) CDO route name listed below is used when pilot requests CDO and when ATC clears CDO. There are altitude restrictions on CDO routes. (b) ATC reclears or cancels CDO when RWY in use is changed. B. Timing for requesting CDO (a) Pilot should request CDO not later than 10 minutes before reaching Top of Descend(TOD) with position of TOD and estimated time over KARIN, RANDY or EVERT. However, pilot which depart from Saga Airport(RJFS) should request CDO not later than 5 minutes before reaching TOD or estimated time over RANDY whichever is earlier.</p>

RWY24

CDO route name	Route
RWY24 CDO Number 1	SUC Y53 BECKY "BECKY DELTA ARRIVAL" [Altitude Restriction] Cross KARIN at or above FL160, cross BECKY at or above 9,000ft, cross EVIAN at or above 6,000ft and cross MAYAH at 4,000ft.
RWY24 CDO Number 2	FUE Y35/OOITA Y351 SALTY Y35 BERTH "BERTH DELTA ARRIVAL" [Altitude Restriction] Cross RANDY at or above FL150, cross BERTH at or above 9,000ft, cross NALTO at or above 6,000ft and cross MAYAH at 4,000ft.
RWY24 CDO Number 3	KEC Y43 KISEI Y46 CANDY "CANDY DELTA ARRIVAL" [Altitude Restriction] Cross EVERT at or above FL160, cross CANDY at or above 10,000ft, cross DATIS at or above 6,000ft and cross MAYAH at 4,000ft.
RWY24 CDO Number 4	TAPOP Y46 CANDY "CANDY DELTA ARRIVAL" [Altitude Restriction] Cross EVERT at or above FL160, cross CANDY at or above 10,000ft, cross DATIS at or above 6,000ft and cross MAYAH at 4,000ft.

RWY06L

CDO route name	Route
RWY06L CDO Number 1	SUC Y53 BECKY "BECKY BRAVO ARRIVAL" [Altitude Restriction] Cross KARIN at or above FL160, cross BECKY at or above 9,000ft, cross EVIAN at or above 6,000ft and cross BERRY at or above 4,000ft.
RWY06L CDO Number 2	FUE Y35/OOITA Y351 SALTY Y35 BERTH "BERTH BRAVO ARRIVAL" [Altitude Restriction] Cross RANDY at or above FL150, cross BERTH at or above 9,000ft, cross NALTO at or above 6,000ft and cross BERRY at or above 4,000ft.
RWY06L CDO Number 3	KEC Y43 KISEI Y46 CANDY "CANDY BRAVO ARRIVAL" [Altitude Restriction] Cross EVERT at or above FL160, cross CANDY at or above 10,000ft, cross DATIS at or above 6,000ft and cross BERRY at or above 4,000ft.
RWY06L CDO Number 4	TAPOP Y46 CANDY "CANDY BRAVO ARRIVAL" [Altitude Restriction] Cross EVERT at or above FL160, cross CANDY at or above 10,000ft, cross DATIS at or above 6,000ft and cross BERRY at or above 4,000ft.

RWY06R

CDO route name	Route
RWY06R CDO Number 1	SUC Y53 BECKY "BECKY ALFA ARRIVAL" [Altitude Restriction] Cross KARIN at or above FL160, cross BECKY at or above 9,000ft, cross EVIAN at or above 6,000ft and cross ALLAN at or above 4,000ft.
RWY06R CDO Number 2	FUE Y35/OOITA Y351 SALTY Y35 BERTH "BERTH ALFA ARRIVAL" [Altitude Restriction] Cross RANDY at or above FL150, cross BERTH at or above 9,000ft, cross NALTO at or above 6,000ft and cross ALLAN at or above 4,000ft.
RWY06R CDO Number 3	KEC Y43 KISEI Y46 CANDY "CANDY ALFA ARRIVAL" [Altitude Restriction] Cross EVERT at or above FL160, cross CANDY at or above 10,000ft, cross DATIS at or above 6,000ft and cross ALLAN at or above 4,000ft.
RWY06R CDO Number 4	TAPOP Y46 CANDY "CANDY ALFA ARRIVAL" [Altitude Restriction] Cross EVERT at or above FL160, cross CANDY at or above 10,000ft, cross DATIS at or above 6,000ft and cross ALLAN at or above 4,000ft.

1.3 コード F 航空機 (ウイングスパン (WS) が 65m 以上 80m 未満) に係る運用等について

1.3.1 特別運用方式

- (1) コード F 航空機にかかるデジタル・アビオニクス
の装備と作動
滑走路 06R/24L に着陸するコード F 航空機の運航者は、正確な進路を維持するため、デジタル・アビオニクスを備え、かつ作動させること。
- (2) 誘導路及びエプロン
- (a) L 誘導路 (E9 と A14 の間) においては、航空機と障害物とのクリアランスを保つため、翼幅が 79m 以上の航空機は減速し、誘導路中心線標識上を厳密に走行すること。
- (b) A380-800 及び B747-8 の地上移動については、それぞれ別図“A380 移動区域”及び“B747-8 移動区域”に示される範囲内に限ること。
- (c) A380-800 及び B747-8 は、A10 又は A12 誘導路を経由して P 誘導路及び L 誘導路相互間を使用しているときは、次に掲げる事項に注意すること。
- ・北向きから南向きへの 180 度回転を行わないこと。
 - ・前脚が誘導路中心線標識に従って走行した場合、主車輪と誘導路縁標識 (A10 及び A12 誘導路の南縁のみ) とのクリアランスが 4.0m 未満となるため、オーバーステアリングにより安全を確保すること。
- (d) A380-800 は、R 誘導経路及び L 誘導経路間の 180 度回転を行わないこと。B747-8 は R 誘導経路 (E1 と E2 の間) 及び L 誘導路 (E1 と E2 の間) 間と N1 誘導経路及び L 誘導路間の 180 度回転を行わないこと。
- (e) B747-8 は R 誘導経路の曲線部 (スポット 8 とスポット 10 の間及び T 誘導経路の曲線部 (スポット 92 とスポット 94 の間) を走行しないこと。
- (f) A380-800 が R 誘導経路 (スポット 10 とスポット 14 の間、スポット 27 とスポット 29 の間、及びスポット 30 とスポット 32 の間) を使用しているときは、L 誘導路 (E1 と E3 の間、及び E6 と E9 の間) の使用機材は翼幅 68m 以下の航空機に限ること。
- (g) A380-800 が L 誘導路 (J1 と E3 の間) を使用しているときは、R 誘導経路 (スポット 9 とスポット 12 の間) 及び N1 誘導経路の使用機材は翼幅 68m 以下の航空機に限ること。
- (h) A380-800 が Q 誘導経路 (スポット 251、252、254、255 の後方) を使用しているときは、J4 誘導路 (S4 と S5 の間) の使用機材は翼幅 78m 以下の航空機に限ること。
- (i) A380-800 が J4 誘導路 (S4 と S5 の間) を使用しているときは、Q 誘導経路 (S4 と S5 の間) の使用機材は翼幅 78m 以下の航空機に限ること。
- (j) A380-800 のスポット 11 への出入りは、E2 誘導路経由とする。
- (k) B747-8 のスポット 9 への出入りは E1 誘導路経由とし、スポット 11 への出入りは E2 誘導路経由とする。
- (l) B747-8 が N1 誘導経路及び R 誘導経路 (スポット 9 とスポット 12 の間) を使用しているときは、L 誘導路 (J1 と E3 の間) の使用機材は翼幅 79m 以下の航空機に限ること。
- (m) B747-8 が L 誘導路 (E1 と E3 の間、及び E6 と E9 の間) を使用しているときは、R 誘導経路 (スポット 10 とスポット 14 の間、スポット 27 とスポット 29 の間、及びスポット 30 とスポット 32 の間) の使用機材は翼幅 79m 以下の航空機に限ること。

1.3 Operation and coordination for Code F Aircraft (wingspan(WS) 65m up to but not including 80m)

1.3.1 Special operational procedure

- (1) Equipment and utilization of Digital Avionics for Code F aircraft
Aircraft operator of Code F aircraft which land on RWY06R/24L should equip and activate digital avionics to maintain the precise path during approach.
- (2) TWY and apron
- (a) In order to keep clearance between other aircraft or obstacle, the aircraft with WS 79m or longer shall reduce taxiing speed and strictly follow the taxiway center line on L-TWY (BTN E9 and A14).
- (b) A380-800 and B747-8 ground movement is only permitted within the areas shown on the attached charts “A380-800 Movement area” and “B747-8 Movement area” respectively.
- (c) A380-800 and B747-8 should pay attention to the followings to taxi between P-TWY and L-TWY through A10 or A12-TWY.
- Aircraft shall NOT make 180-degree turn, heading from North to South.
 - Aircraft shall oversteer when turning into/out of TWY, not to run off the edge of TWY, as the clearance between the main gears and the edge marking of A10 or A12-TWY (south side only) becomes less than 4.0m, when the nose gears of those aircraft follow TWY CL marking.
- (d) A380-800 shall NOT make 180-degree turn BTN L-TWY and R aircraft stand taxilane.
B747-8 shall NOT make 180-degree turn BTN L-TWY (BTN E1 and E2) and R aircraft stand taxilane (BTN E1 and E2), and N1 aircraft stand taxilane and L-TWY.
- (e) B747-8 shall NOT taxi the curved section of R aircraft stand taxilane (BTN spot 8 and spot 10) and T aircraft stand taxilane (BTN spot 92 and spot 94).
- (f) When A380-800 is on R aircraft stand taxilane (BTN spot 10 and spot 14, spot 27 and spot 29, and spot 30 and spot 32), WS of the aircraft on L-TWY (BTN E1 and E3, E6 and E9), right beside the A380-800, should be 68m or less.
- (g) When A380-800 is taxiing on L-TWY (BTN J1 and E3), WS of the aircraft on R aircraft stand taxilane (BTN spot 9 and spot 12) and N1 aircraft stand taxilane, right beside the A380-800, should be 68m or less.
- (h) When A380-800 is on Q aircraft stand taxilane (behind spot 251, 252, 254 and 255), WS of the aircraft on J4-TWY (BTN S4 and S5), right beside the A380-800 should be 78m or less.
- (i) When A380-800 is taxiing on J4-TWY (BTN S4 and S5), WS of the aircraft on Q aircraft stand taxilane (BTN S4 and S5), right beside the A380-800, should be 78m or less.
- (j) To and from stand 11, A380-800 should take E2-TWY.
- (k) To and from stand 9, B747-8 should take E1-TWY, also to and from stand 11, B747-8 should take E2-TWY.
- (l) When B747-8 is taxiing on N1 and R aircraft stand taxilane (BTN spot 9 and spot 12), WS of the aircraft on L-TWY (BTN J1 and E3), right beside the B747-8, should be 79m or less.
- (m) When B747-8 is taxiing on L-TWY (BTN E1 and E3, E6 and E9), WS of the aircraft on R aircraft stand taxilane (BTN spot 10 and spot 14, spot 27 and spot 29, and spot 30 and spot 32), right beside the B747-8 should be 79m or less.

(3) 使用可能スポット

- (a) A380-800 が駐機可能なスポットは、11、V1、28、31、101、215、251、255、256、257 及び M6 である。なお、スポット 101 においては、破線で示された導入線を活用すること。
- (b) B747-8 が駐機可能なスポットは、9、11、101、201、214L、215、251、255、256、257 及び M6 である。

1.3.2 空港管理者との調整事項

翼幅 65m 以上の R スポット誘導経路を使用する航空機の運航者及び、翼幅 70m 以上の Q 及び T スポット誘導経路を使用する運航者は、当該機と作業車両との間の安全クリアランスを確保するため、空港管理者と調整すること。

(3) Parking stands

- (a) Parking stands for A380-800 are 11, V1, 28, 31, 101, 215, 251, 255, 256, 257 and M6. In addition, on parking stand 101, use the broken lead-in line.
- (b) Parking stands for B747-8 are 9, 11, 101, 201, 214L, 215, 251, 255, 256, 257 and M6.

1.3.2 Coordination with airport administrator

Operators of the aircraft which WS is 65m or longer taxis on R aircraft stand taxilane, and which WS is 70m or longer taxis on Q and T aircraft stand taxilane should coordinate with airport administrator to ensure required clearance between the aircraft and vehicles.

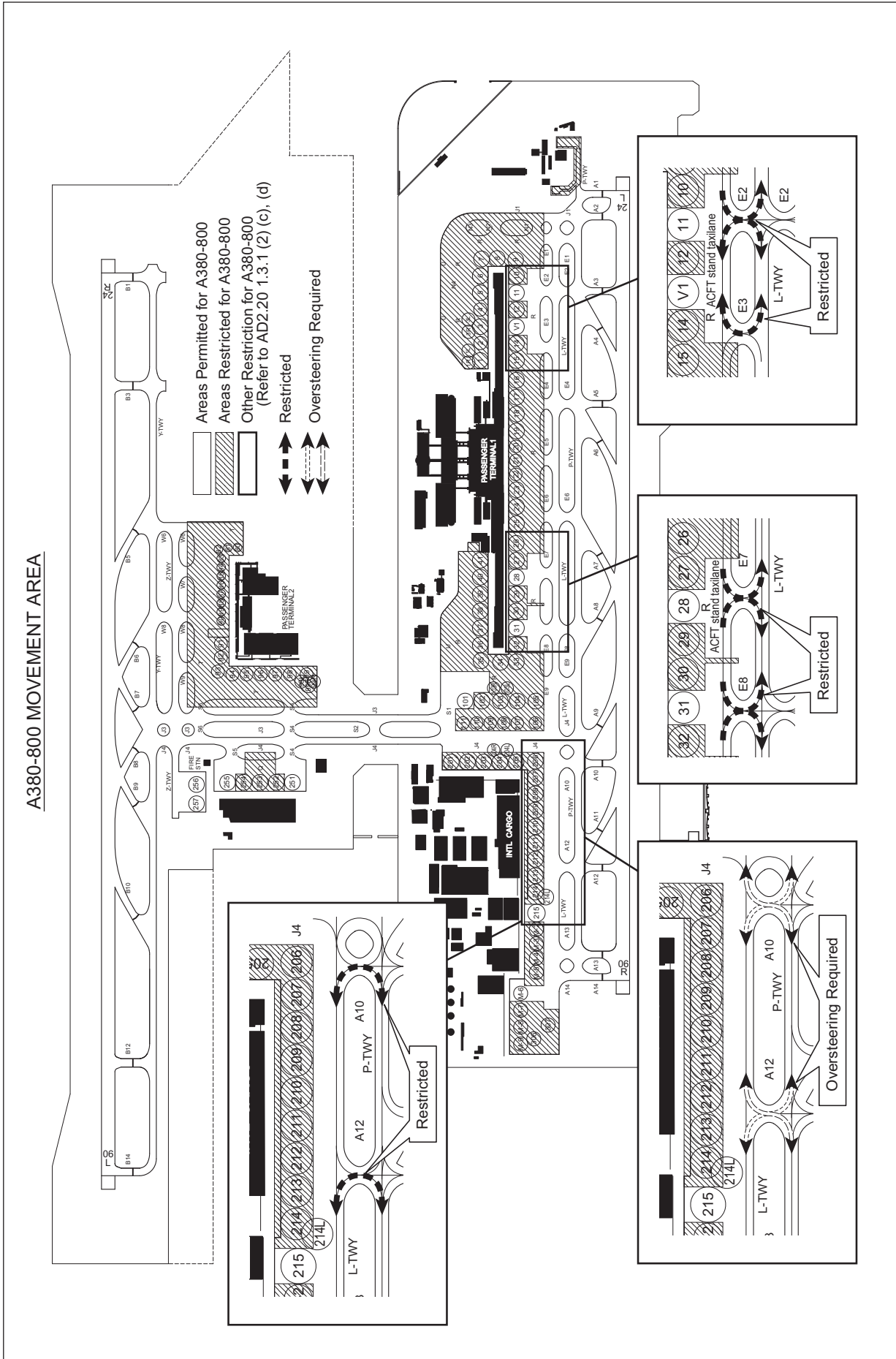

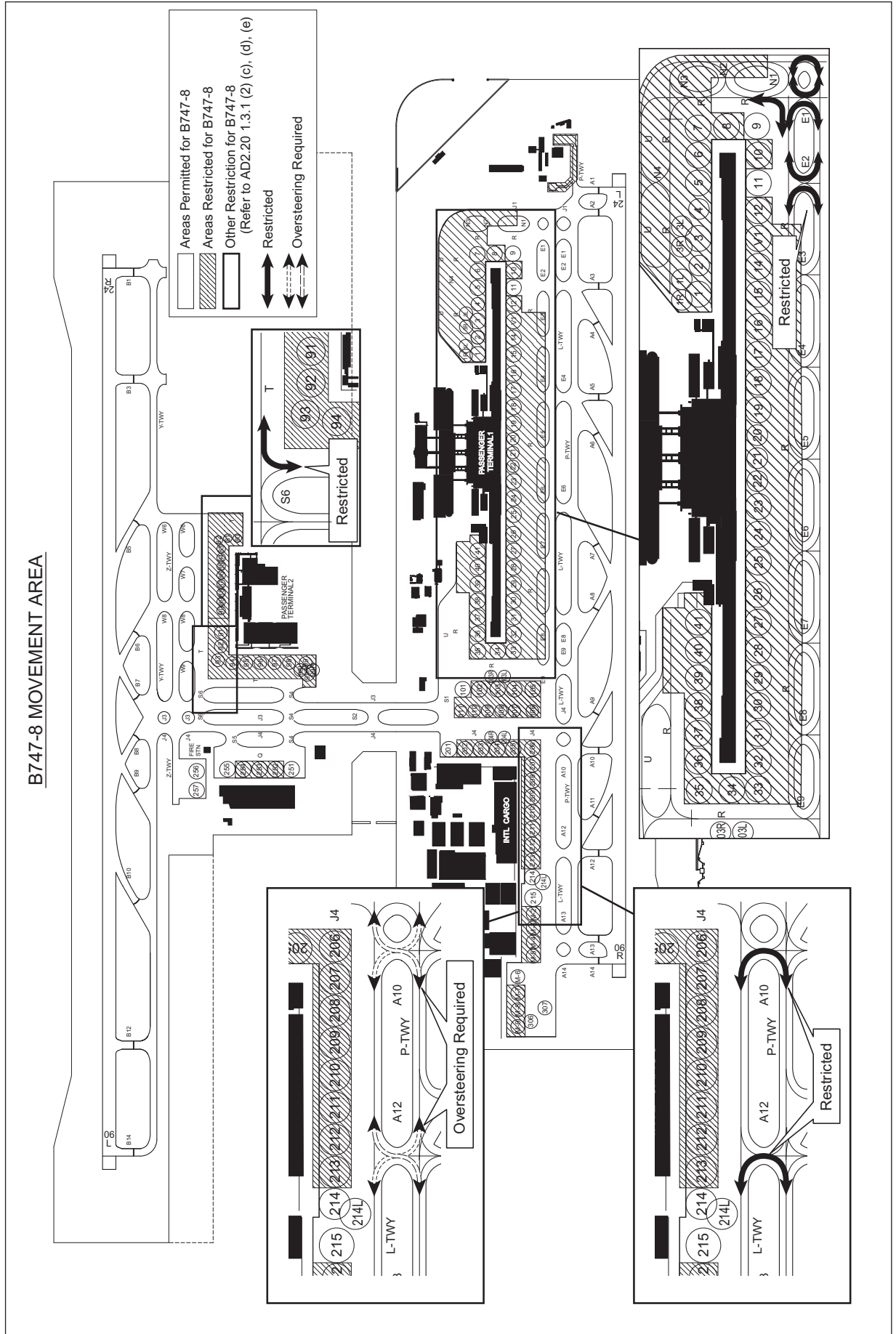

1.4 補助動力装置 (APU) の使用制限

航空機が固定動力設備付きのスポットを使用する場合は、管理者が特に認める場合を除き、次に掲げる時間を超えて補助動力装置を使用してはならない。

- (1) 出発予定時刻前の 15 分間
- (2) 到着後、固定動力設備が使用可能となるまでに必要とする最小限度の時間
- (3) 航空機が点検整備のため補助動力装置を必要とする場合は最小限度の時間

注：スポット 1～41 および 201～215 は固定動力設備が設置されている。
 スポット 1～41 は固定電源設備および空調設備が設置されている。
 スポット 201～215 は固定電源設備が設置されている。

1.4 Restrictions about the use of auxiliary power units (APU).

When an aircraft is using an aircraft parking stand with fixed power facilities, APU shall not be used outside the time periods specified below except when specifically acknowledge by the authority as necessary.

- (1) Less than 15 minutes prior to the estimated off-block time.
- (2) The minimum time required for switching over to the fixed power facilities, after arrival at the parking stand.
- (3) For the minimum time required for aircraft maintenance purposes if needed.

NOTE:
 Spot 1 - 41 and 201 - 215 are aircraft parking stands with fixed power facilities.
 Spot 1 - 41 are equipped with electric power unit and pre-conditioned air unit.
 Spot 201 - 215 are equipped with electric power unit.

1.5 V1 スポットの使用

スポット V1 にて VIP 用の導入線を使用する場合、空港管理者による許可が必要である。
 (RJBB AD2.24 参照)

1.5 Using V1-Spot

Using Guidance line for VIP stand at V1-Spot, prior permission of the Airport Administrator is required. (See RJBB AD2.24)

1.6 PDA (parts departing aircraft) reporting to Airport Administration

In order to secure the safety of aircraft operations and to rectify the issue of falling objects from aircraft operating in the vicinity of Kansai International Airport, aircraft operators are required to notify Airport Administration (Tel 072-455-2221, Fax 072-455-2055, E-mail ops@kansai-airports.co.jp) of any "Parts Departing Aircraft" from flights operating to/from Kansai International Airport, without delay. This information shall be shared by relevant parties in order to prevent recurrence of such.

2. Taxiing to and from stands

2.1 Standard taxiing route

The standard taxiing routes for departure and arrival may be instructed by ATC, using route ID in the table below. These routes are also used for joining and leaving on the way.

	Direction	Route ID	Routing Via
Departure	To Y-TWY	Route 1	R-E1-L-J4
Arrival	From Y-TWY		J4-L-E1-R

	Direction	Route ID	Routing Via
Departure	To Y-TWY	Route 2	R-E1-L-E9-R-S1-J3
Arrival	From Y-TWY		J3-S1-R-E9-L-E1-R

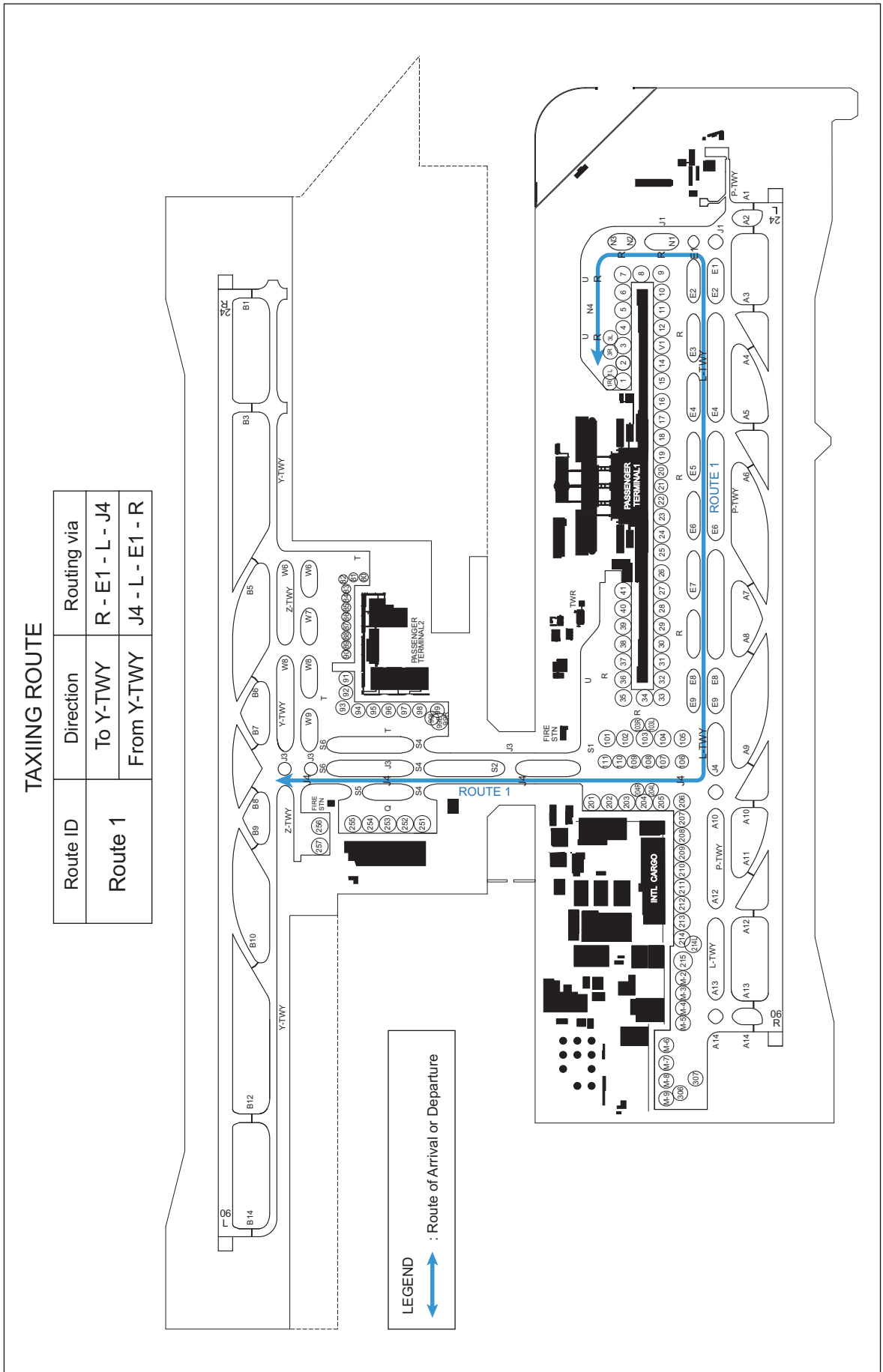

2.2 エプロン等における安全対策

- (1) エプロン地区での航空機の走行は、厳密に黄色いガイドラインに沿うこと。
- (2) エプロン地区で走行する際及びエプロン地区から誘導路へ走行する際は、ブラストによる危険の原因にならないようにエンジンの出力を絞ること。
- (3) スポット毎のエンジンスター位置は、原則として以下の場所とする。ただし、別途異なる方法を指示されたときは、この限りでない。
 - a) スポット 8
機首を東又は西向きにする場合は、メインギアがスポット 8 の導入線上にある位置。
 - b) 上記以外のスポットに係るプッシュバック方法及びエンジンスター位置は、空港管理者が別途定める規程を確認すること。
 - c) 以上によりがたい場合は、空港管理者と調整すること。
- (4) ジェットブラストによる影響の回避及び翼端クリアランス確保のため、スポット 80、82、84、86、88 及びスポット 90 から 99 までにおける自走アウトは、次の方式に従うこと。
 - a) 自走アウトは、A320 型機に限ること。
 - b) 自走アウト時は、ブラストの影響が出ないことを確認の上行うこと。
 - c) 旋回線とノーズギアのずれを監視する地上監視員の信号に従うこと。
 - d) 自走アウト開始位置は別図 2 の場所とし、旋回線曲部における旋回角は、スポット 80、82、84、86、88、90 は 55° 以上、スポット 91 から 99 までは 65° 以上であること。
 - e) 自走アウト時における停止操作を行った際には、以下の手順を行うこと。
 - 1) 全エンジンをシャットダウン
 - 2) 自走開始位置もしくは T 誘導経路手前までけん引で機体を移動

2.2 Safety measures in Aprons

- (1) While maneuvering in the apron area, follow strictly yellow guide lines.
- (2) When aircraft maneuvering in the apron and out to a taxiway, reduce engine power to the extent practicable to avoid blast damage.
- (3) The engine start positions are designated as follows, unless other positions are instructed.
 - a) spot 8
The position that the main gear of the aircraft on the lead-in line of spot 8 in case of facing east or west pushback
 - b) Pushback procedure and engine start position for other spots are listed in the regulation established by airport administrator.
 - c) Coordination with airport administrator is required in case of the situation unable to comply the regulation.
- (4) In order to avoid jet blast damage and ensure wingtip clearance, operators shall comply with the following power-out procedure on spot 80, 82, 84, 86, 88 and 90 through 99.
 - a) Only A320 may use the lead-out line.
 - b) Operators must confirm jet blast cause no damage when maneuvering on spot.
 - c) Follow the signals sent by the ground staff who is monitoring the deviation between circling line and nose gear.
 - d) Starting point for power-out is shown on ATTACHMENT 2, and while maneuvering on the curved section of the circling lines, nose gear steering angle shall be at or above 55° on spot 80, 82, 84, 86, 88, 90 and at or above 65° on spot 91 through 99.
 - e) Following procedures shall be taken in case of a stop when maneuvering on spot.
 - 1) Shut down all engines.
 - 2) Tow the aircraft to starting point for power-out or short of T aircraft stand taxilane.

別図 (ATTACHMENT-1)

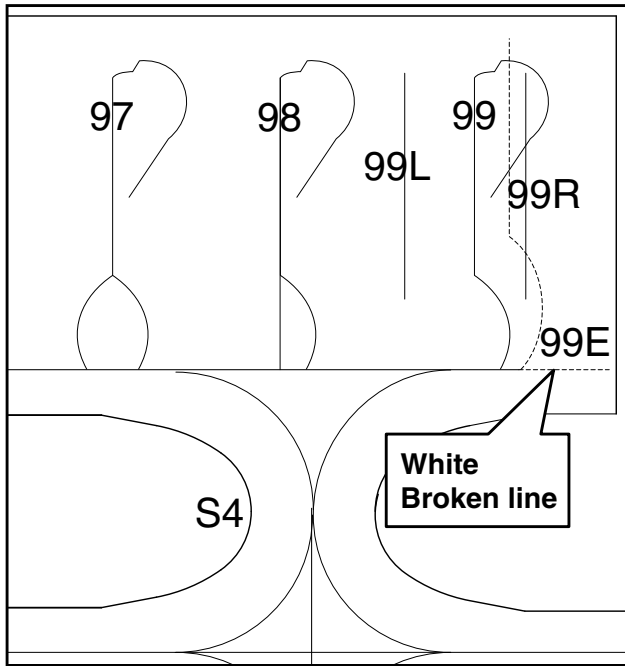

別図 (ATTACHMENT-2)

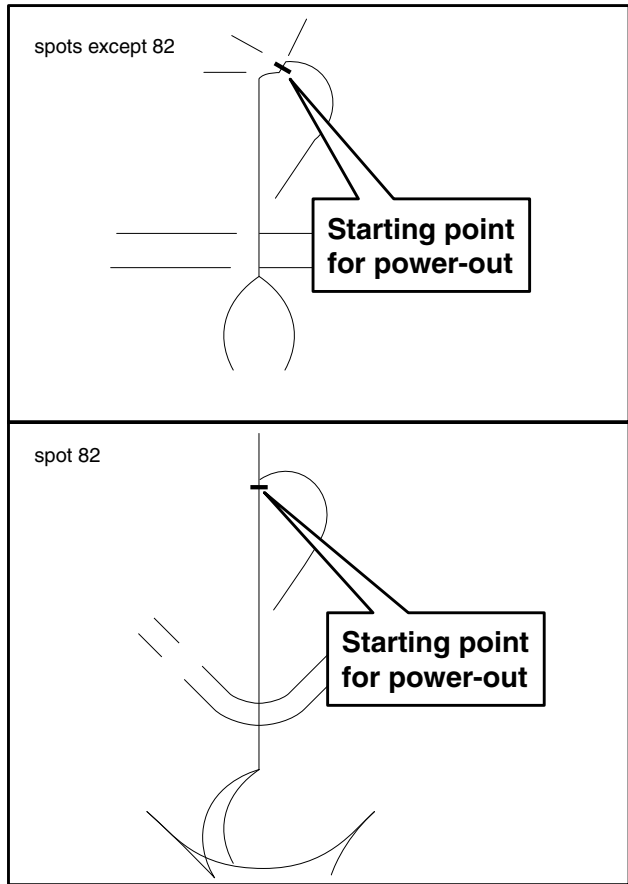

3. Parking area for small aircraft(General aviation)

Nil

4. Parking area for helicopters

Nil

5. Apron - taxiing during winter conditions

Nil

6. Taxiing - limitations

<p>6.1 誘導路の制限</p> <p>誘導路 A1 の交差点から北の終点までの誘導路 P は、最大離陸重量が23500kg(51807lb)以下の航空機のみ使用可能である。</p>	<p>6.1 Restricted taxiway</p> <p>P taxiway from the junction of A1 taxiway to north end (18m in width) is only available to aircraft having a maximum take-off weight 23500kg(51807lb) or less.</p>
---	--

<p>6.2 誘導路交差点の翼端クリアランス (AD1.1.6.8 参照)</p> <p>誘導路上の停止位置に待機中の航空機と後方の誘導路を走行する航空機の翼端クリアランスは以下のとおりである。</p> <p>When B744 holding at the stop marking on TWY A2,A3,A5,A10,A12 or A13</p> <table border="1" style="width: 100%; border-collapse: collapse; margin-bottom: 5px;"> <tr> <td style="width: 40%;">Wing Span (WS) of aircraft taxiing on P TWY</td> <td style="width: 30%;">WS ≤23.4m</td> <td style="width: 30%;">WS >23.4m</td> </tr> <tr> <td>Wing tip clearance</td> <td style="text-align: center;">*B</td> <td style="text-align: center;">*C</td> </tr> </table> <p>When B772 holding at the stop marking on B3 or B12</p> <table border="1" style="width: 100%; border-collapse: collapse;"> <tr> <td style="width: 40%;">Wing Span (WS) of aircraft taxiing on Y TWY</td> <td style="width: 30%;">WS ≤19.6m</td> <td style="width: 30%;">WS >19.6m</td> </tr> <tr> <td>Wing tip clearance</td> <td style="text-align: center;">*B</td> <td style="text-align: center;">*C</td> </tr> </table>	Wing Span (WS) of aircraft taxiing on P TWY	WS ≤23.4m	WS >23.4m	Wing tip clearance	*B	*C	Wing Span (WS) of aircraft taxiing on Y TWY	WS ≤19.6m	WS >19.6m	Wing tip clearance	*B	*C	<p>6.2 Wing tip clearance at the TWY intersection (REF. AD1.1.6.8)</p> <p>Wing tip clearance at the TWY intersection between the aircraft holding at the stop marking on the TWY and the other aircraft taxiing behind it are as follows.</p> <p style="margin-top: 20px;">Legend: *B:6.5m ≤ wing tip clearance < 15m *C:wing tip clearance < 6.5m</p>
Wing Span (WS) of aircraft taxiing on P TWY	WS ≤23.4m	WS >23.4m											
Wing tip clearance	*B	*C											
Wing Span (WS) of aircraft taxiing on Y TWY	WS ≤19.6m	WS >19.6m											
Wing tip clearance	*B	*C											

7. School and training flights - technical test flights - use of runways

Nil

8. Helicopter traffic - limitation

Nil

9. Removal of disabled aircraft from runways

Nil

RJBB AD 2.21 NOISE ABATEMENT PROCEDURES

<p>1. 騒音軽減運航方式 (AIP AD1.1 6.5 参照)</p> <p>1.1 空港周辺における航空機騒音軽減のため、運航の安全に支障のない範囲で、以下の方式が適用される。ただし、これらの方式によることができない航空機は実効的にこれらと同等と認められる代替方式を実施するものとする。</p> <p>i) 離陸について なし</p> <p>ii) 着陸について (滑走路 06R/06L)</p> <p>a) ディレイド・フラップ進入方式 1500 フィート通過後、最終着陸フラップ角とすること</p> <p>b) 2500 フィート通過後、脚下げを行うこと</p> <p>iii) リバース・スラストについて なし</p> <p>1.2 優先滑走路方式 なし</p> <p>1.3 優先飛行経路 なし</p>	<p>1. Noise Abatement Operating Procedures (See AIP AD1.1 6.5)</p> <p>1.1 In order to reduce aircraft noise in the vicinity of airport, the following procedures shall be applied unless compliance of the procedures adversely affects the safety of aircraft operations. In case that the aircraft is unable to take these procedures, pilots should execute alternative procedures which are considered to be practically equivalent.</p> <p>i) For take-off Nil</p> <p>ii) For landing to RWY 06R/06L</p> <p>a) Delayed Flap Approach Procedure Extend final landing flaps after leaving 1,500feet.</p> <p>b) Make gear down after leaving 2,500 feet.</p> <p>iii) Reverse Thrust Nil</p> <p>1.2 Preferential Runways Procedures Nil</p> <p>1.3 Noise Preferential Routes Nil</p>
--	--

<p>2. 標準計器出発方式の使用</p> <p>空港周辺における航空機騒音軽減のため、すべての出発機は、原則として、次の標準計器出発方式により飛行すること。</p>	<p>2. USE of SIDs</p> <p>In order to reduce aircraft noise around the airport, in principle, all departure aircraft are requested to fly via the following SIDs.</p>
--	---

EOBT between 2115UTC and 1329UTC	
Destination(area or airport)	SIDs
Europe/Middle East/Southeast Asia/Macau/ Hong Kong/Taiwan/China/Korea/ Northern Kyushu/Central Kyushu/Shikoku	HELEN DEPARTURE (for RNAV1) MAIKO DEPARTURE
Okinawa/Southern Kyushu/Shikoku	DAISY DEPARTURE (for RNAV1)
Europe/Eastern part of North America/ Western part of Hokkaido/Hokuriku	NANKO DEPARTURE (for RNAV1)
Eastern part of Hokkaido/Tohoku/RJTT	ISPUM DEPARTURE (for RNAV1)
Eastern part of North America/ Western part of North America/Hawaii/ South Pacific/Australia/Southeast Asia/ Macau/Hong Kong/Taiwan/Okinawa/RJAA	SUSAN DEPARTURE (for RNAV1) TOMOH DEPARTURE

EOBT between 1330UTC and 2114UTC		
Destination(area or airport)	RWY	SIDs
Europe/Middle East/China/Korea/ Hokkaido/Tohoku/Hokuriku/ Northern Kyushu/Central Kyushu/Shikoku	06R/L	HELEN DEPARTURE (for RNAV1) MAIKO DEPARTURE
	24R/L	IWAYA DEPARTURE (for RNAV1) FERRY DEPARTURE
North America/Hawaii/South Pacific/Australia/ Southeast Asia/Macau/Hong Kong/ Taiwan/Okinawa/Southern Kyushu/Kanto	06R/L	SUSAN DEPARTURE (for RNAV1) TOMOH DEPARTURE
	24R/L	KITAN DEPARTURE (for RNAV1) TOMOH WEST DEPARTURE

RJBB AD 2.22 FLIGHT PROCEDURES

1. TAKE OFF MINIMA								
	RWY	ACFT CAT	REDL & RCLL		REDL or RCLL or RCL Marking		NIL (DAYTIME ONLY)	
			RVR	VIS	RVR	VIS	RVR	VIS
Multi-Engine ACFT with TKOF ALTN AP FILED	06R 06L 24R 24L	A, B, C	400m *200m **150m	400m *200m	400m *250m	400m *250m	-	500m
		D	400m *250m **200m	400m *250m	400m *300m	400m *300m	-	500m
OTHER	06R 06L 24R 24L	A, B, C, D	AVBL LDG MINIMA					

* APPLICABLE WHEN LVP/LVPD IN FORCE

** APPLICABLE WHEN LVP/LVPD IN FORCE and MULTIPLE RVRs AVAILABLE

2. Lost communication procedures for arrival aircraft under radar navigational guidance

If radio communications with Kansai Approach/Radar are lost for 1 minute, squawk Mode A/3 Code 7600 and ;

- (I) 1. Contact Kansai Tower.
- 2. If unable, proceed in accordance with Visual Flight Rules.
- 3. If unable,
 - (1) RWY 06L or RWY 06R in use; proceed to GATES at last assigned altitude or 4,000 feet whichever is higher, and execute instrument approach.
 - (2) RWY 24L or RWY 24R in use; proceed to MAYAH at last assigned altitude or 4,000 feet whichever is higher, and execute instrument approach.

(II) Procedures other than above will be issued when situation required.

3. Trajectorized Airport Traffic Data Processing System(TAPS)

Aircraft flying under control of Kansai approach control in the approach control area will be instructed to reply with discrete code on Mode A/3 and Mode C.

If an aircraft with non-discrete code capability be instructed to reply with the discrete code, it shall report a controller accordingly.

関西アプローチの指示のもとに、当該進入管制区を飛行する航空機は、モード A/3 の二次レーダー個別コード及びモード C による応答を指示される。

二次レーダー個別コードを搭載していない航空機が当該コードによる応答を指示された場合は、管制官に対し、その旨通報すること。

4. Category II Operations at Kansai International Airport

関西国際空港におけるカテゴリーII 運航

4.1. Facilities

The following facilities are available:

Runway 06R	Runway 24L
<ul style="list-style-type: none"> • ILS Runway 06R - CAT II • Lighting system Runway 06R - CAT II • RVR by forward-scatter meters (the touchdown zone, the mid-point and stop-end of the runway) 	<ul style="list-style-type: none"> • ILS Runway 24L - CAT II • Lighting system Runway 24L - CAT II • RVR by forward-scatter meters (the touchdown zone, the mid-point and stop-end of the runway)
Runway 06L	Runway 24R
<ul style="list-style-type: none"> • ILS Runway 06L - CAT II • Lighting system Runway 06L - CAT II • RVR by forward-scatter meters (the touchdown zone, the mid-point and stop-end of the runway) 	<ul style="list-style-type: none"> • ILS Runway 24R - CAT II • Lighting system Runway 24R - CAT II • RVR by forward-scatter meters (the touchdown zone, the mid-point and stop-end of the runway)

4.2 Conditions

A. The following systems must be operative:

For ILS RWY06R approach (CAT II)	For ILS RWY 24L approach (CAT II)
(1) ILS comprising; <ul style="list-style-type: none"> • ILS-LOC 06R with standby transmitter • ILS-GP 06R with standby transmitter (When any standby transmitters unserviceable, downgrade ILS-CAT I.) • IM06R (When IM unserviceable, RA could be used as an alternate method) • ILS-DME 06R 	(1) ILS comprising; <ul style="list-style-type: none"> • ILS-LOC 24L with standby transmitter • ILS-GP 24L with standby transmitter (When any standby transmitters unserviceable, downgrade ILS-CAT I.) • IM24L (When IM unserviceable, RA could be used as an alternate method) • ILS-DME 24L
(2) Lighting systems comprising; <ul style="list-style-type: none"> • PALS 06R (including side row barrettes) • High INTST REDL • High INTST RTHL • RCLL and RTZL 	(2) Lighting systems comprising; <ul style="list-style-type: none"> • PALS 24L (including side row barrettes) • High INTST REDL • High INTST RTHL • RCLL and RTZL
(3) Secondary power supply	(3) Secondary power supply
(4) RVR by forward-scatter meters at the touchdown zone and either (the mid-point or stop-end of the runway).	(4) RVR by forward-scatter meters at the touchdown zone and either (the mid-point or stop-end of the runway).
For ILS RWY06L approach (CAT II)	For ILS RWY24R approach (CAT II)
(1) ILS comprising; <ul style="list-style-type: none"> • ILS-LOC 06L with standby transmitter • ILS-GP 06L with standby transmitter (When any standby transmitters unserviceable, downgrade ILS-CAT I.) • IM06L (When IM unserviceable, RA could be used as an alternate method) • ILS-DME 06L 	(1) ILS comprising; <ul style="list-style-type: none"> • ILS-LOC 24R with standby transmitter • ILS-GP 24R with standby transmitter (When any standby transmitters unserviceable, downgrade ILS-CAT I.) • IM24R (When IM unserviceable, RA could be used as an alternate method) • ILS-DME 24R
(2) Lighting systems comprising; <ul style="list-style-type: none"> • PALS 06L (including side row barrettes) • High INTST REDL • High INTST RTHL • RCLL and RTZL 	(2) Lighting systems comprising; <ul style="list-style-type: none"> • PALS 24R (including side row barrettes) • High INTST REDL • High INTST RTHL • RCLL and RTZL
(3) Secondary power supply	(3) Secondary power supply
(4) RVR by forward-scatter meters at the touchdown zone and either (the mid-point or stop-end of the runway).	(4) RVR by forward-scatter meters at the touchdown zone and either (the mid-point or stop-end of the runway).

B. The following information must be currently available:

- 1) Surface wind speed and direction
- 2) RVR

C. ITEM A and/or B are not met, the relevant information will be notified to the pilots as soon as practicable.

4.3 Precision Approach Terrain Profile Chart

See RJBB AD2.24

4.4 Operating Minimum

Approach minima stated in AD2.24 (Instrument Approach Chart) are observed.

4.5 LVP

LVP will be available when the following conditions are met:

- a) Ceiling is at or less than 200ft and/or RVR is at or less than 550m.
- b) Facilities listed 1.above are operational.
- c) ILS Critical Area is protected.

In order to protect Critical Area for the succeeding arrival aircraft, an arrival aircraft may be given following instruction by ATC.

" REPORT OUT OF ILS CRITICAL AREA "

The exit taxiway center line lights are fixed alternate green and yellow inside the ILS Critical Area. If an aircraft is given the above instruction, she is expected to advise the ATC when the taxiway center line lights change from alternate green and yellow to steady green.

4.6 Approval for CAT II Operations

Operators must obtain operational approval from the State of Registry or the State of Operator, as appropriate, to conduct CAT II Operations. (See GEN1.5)

5. LVTO at Kansai International Airport

5.1. Facilities

The following facilities are available:

RWY 06R	RWY 24L
<ul style="list-style-type: none"> • Lighting system RWY 06R for LVTO • RVR by forward-scatter meters (the touchdown zone, the mid-point and stop-end of the runway) 	<ul style="list-style-type: none"> • Lighting system RWY 24L for LVTO • RVR by forward-scatter meters (the touchdown zone, the mid-point and stop-end of the runway)
RWY 06L	RWY 24R
<ul style="list-style-type: none"> • Lighting system RWY 06L for LVTO • RVR by forward-scatter meters (the touchdown zone, the mid-point and stop-end of the runway) 	<ul style="list-style-type: none"> • Lighting system RWY 24R for LVTO • RVR by forward-scatter meters (the touchdown zone, the mid-point and stop-end of the runway)

5.2. Conditions

A. The following systems must be operative:

For LVTO
(1) Lighting system comprising; <ul style="list-style-type: none">• High INTST REDL• High INTST RENL• RCLL
(2) Secondary power supply

B. The following information must be currently available:

- a) Surface wind speed and direction.
- b) RVR or VIS

C. ITEM A and/or B are not met, the relevant information will be notified to the pilots as soon as practicable.

5.3. Operating Minima

Take-off minima stated in AD2.22(TAKE-OFF MINIMA) are observed.

5.4. LVP/LVPD

LVP/LVPD will be available when the following conditions are met:

- a) RVR is at or less than 400m.
- b) Facilities listed 1. above are operational.

5.5. RWY-Holding position Marking

RWY-holding position markings are displayed on taxiways A1 through A14 their locations are 90m off the runway center line.

Note: The common way of its markings is shown in RJBB AD2.24

RJBB AD 2.23 ADDITIONAL INFORMATION

1. 滑走路の定期メンテナンス時間

滑走路および施設を維持するため定期的に滑走路は使用不可となる。(NOTAM RJBB 参照)

1. Scheduled maintenance hours on the runway

Scheduled runway unserviceability due to runway and facilities maintenance (See NOTAM RJBB).

RJBB AD 2.24 CHARTS RELATED TO AN AERODROME

Aerodrome/Heliport Chart-1
Aerodrome/Heliport Chart-2
Aerodrome Ground Movement Chart
Aerodrome Obstacle Chart-ICAO type A (RWY06R/24L)
Aerodrome Obstacle Chart-ICAO type A (RWY06L/24R)
Aerodrome Obstacle Chart-ICAO type B
Precision Approach Terrain Chart (RWY06R)
Precision Approach Terrain Chart (RWY24L)
Precision Approach Terrain Chart (RWY06L)
Precision Approach Terrain Chart (RWY24R)
Standard Departure Chart - Instrument (MAIKO)
Standard Departure Chart - Instrument (FERRY)
Standard Departure Chart - Instrument (TOMOH)
Standard Departure Chart - Instrument (KITAN, SUSAN - RNAV)
Standard Departure Chart - Instrument (ISPUM - RNAV)
Standard Departure Chart - Instrument (NANKO - RNAV)
Standard Departure Chart - Instrument (HELEN, IWAYA - RNAV)
Standard Departure Chart - Instrument (DAISY - RNAV)
Standard Arrival Chart - Instrument (AKASI)
Standard Arrival Chart - Instrument (GATES)
Standard Arrival Chart - Instrument (ALVIS, BURTN-RNAV)
Standard Arrival Chart - Instrument (MAYAH-RNAV)
Standard Arrival Chart - Instrument (DANDE-RNAV)
Standard Arrival Chart - Instrument (ALISA, BECKY, CANDY-RNAV)
Standard Arrival Chart - Instrument (BERTH-RNAV)
Standard Arrival Chart - Instrument (DATIS-RNAV)
Standard Arrival Chart - Instrument (ALISA, BECKY, BERTH, CANDY-RNAV)
Instrument Approach Chart (ILS Z or LOC Z RWY06L (CAT II))
Instrument Approach Chart (ILS Y or LOC Y RWY06L (CAT II))
Instrument Approach Chart (ILS Z or LOC Z RWY06R (CAT II))
Instrument Approach Chart (ILS Y or LOC Y RWY06R (CAT II))
Instrument Approach Chart (ILS Z or LOC Z RWY24L (CAT II))
Instrument Approach Chart (ILS Y or LOC Y RWY24L (CAT II))
Instrument Approach Chart (ILS Z or LOC Z RWY24R (CAT II))
Instrument Approach Chart (ILS Y or LOC Y RWY24R (CAT II))
Instrument Approach Chart (VOR RWY06L)
Instrument Approach Chart (VOR RWY24R)
Instrument Approach Chart (RNP RWY06L)
Instrument Approach Chart (RNP RWY06R)
Instrument Approach Chart (RNP RWY24L)
Instrument Approach Chart (RNP RWY24R)
Other Chart (HOLDING PATTERN)
Other Chart (HOLDING PATTERN-RNAV)
Other Chart (Visual REP)
Other Chart (LDG CHART)
Other Chart (MVA CHART)

INTENTIONALLY LEFT BLANK

AERODROME CHART

KANSAI INTERNATIONAL AIRPORT

ELEV 5.3m(17.4ft)

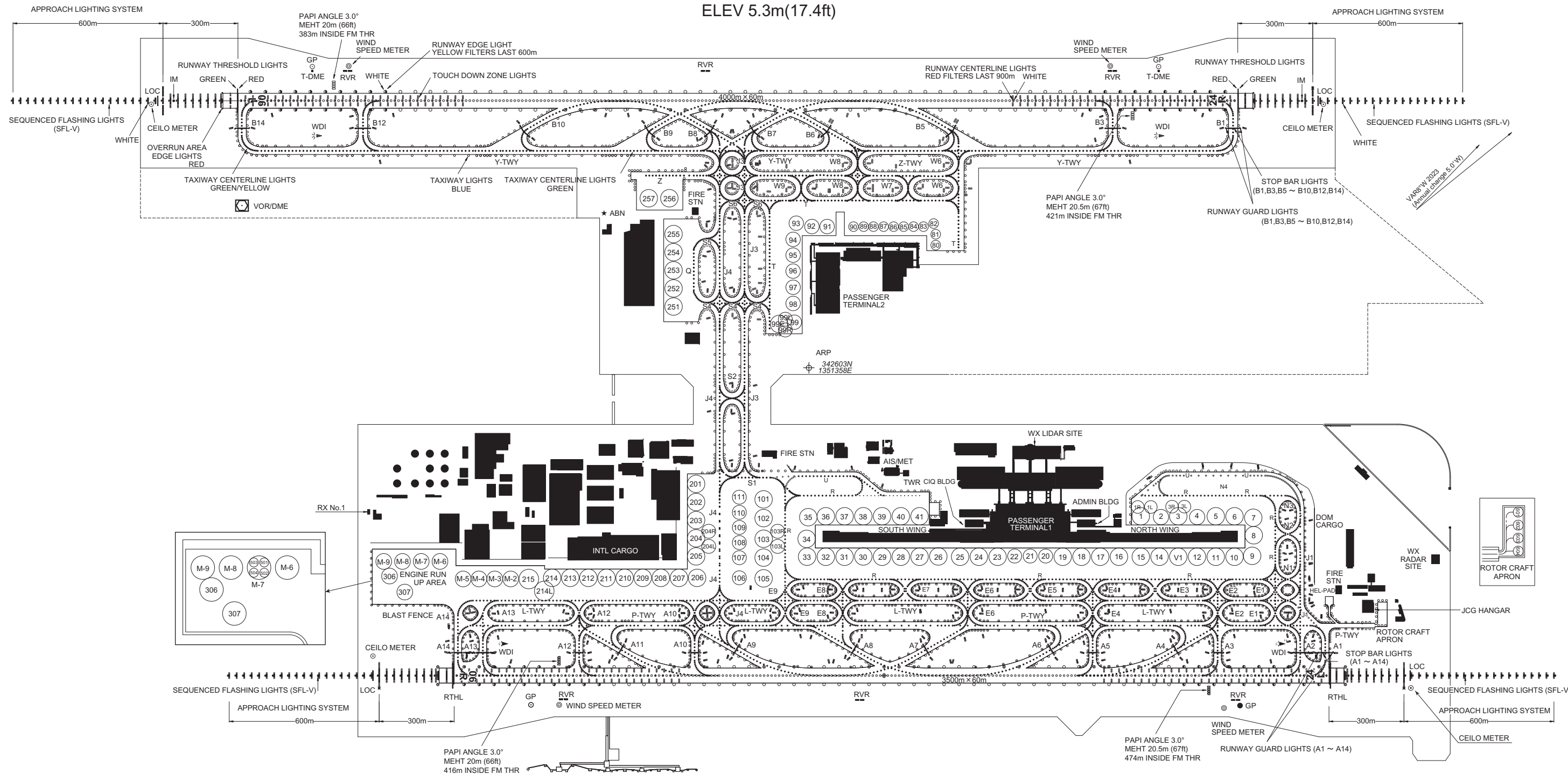

CHANGE : VAR.

RJBB / KANSAI INTL

AD CHART

CHANGE : VAR.

Designation	Call Sign	Frequency (MHz)
ATIS	Kansai INTL Airport	127.85
DLVRY	Kansai Delivery	121.9 126.2
GND	Kansai Ground	121.6 121.65 118.575 126.2
TWR	Kansai Tower	118.2 118.05 126.2 236.8

KANSAI INTL AP
ELEV 5.3m(17.4ft)

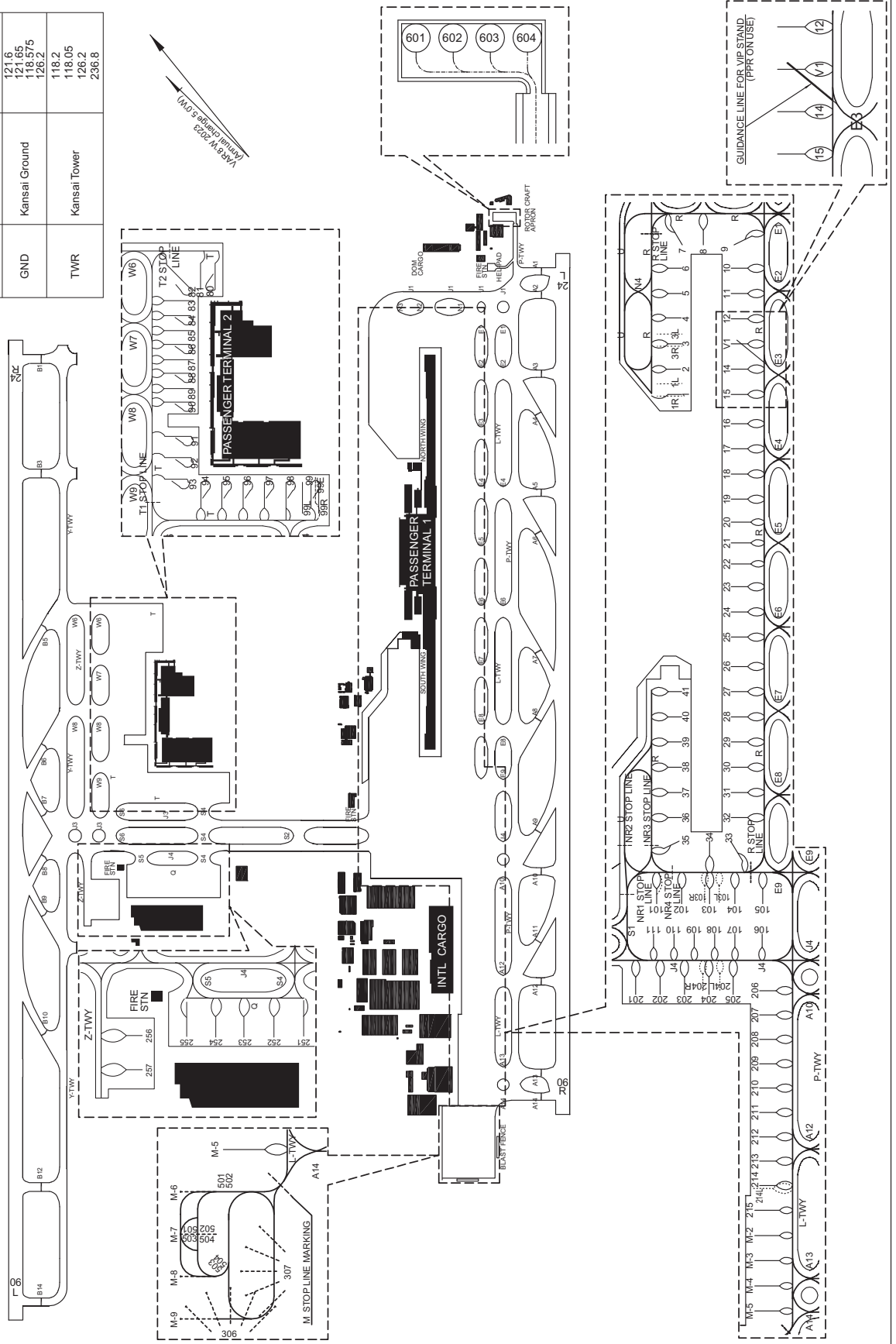

TAXIING GUIDE LINES AND PARKING AREAS

VAR: V 2023
(Annual Change: 5.0°W)

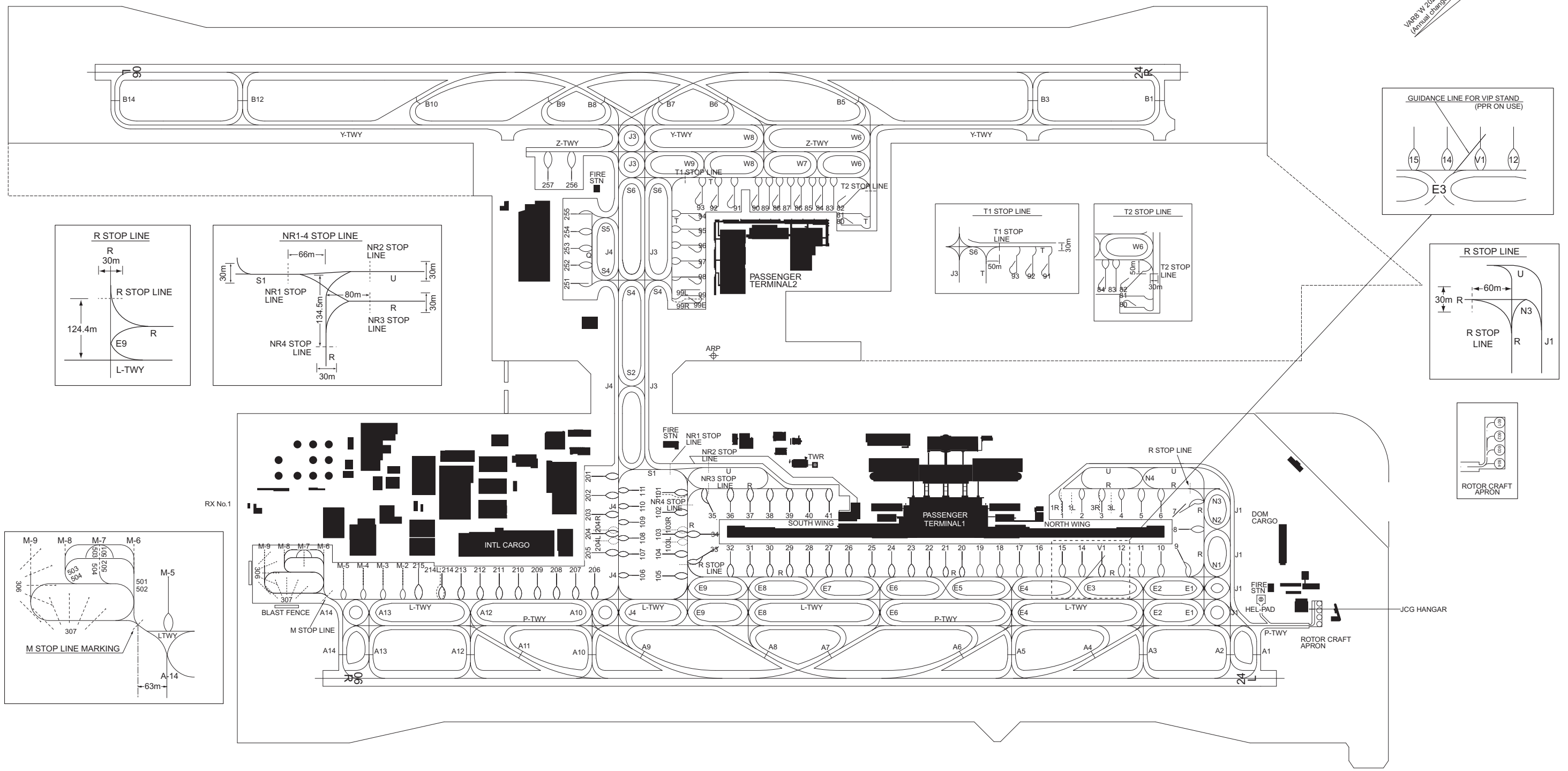

CHANGE : VAR.

AERODROME OBSTACLE CHART-ICAO TYPE A (OPERATIONAL LIMITATIONS)

DIMENSIONS AND ELEVATIONS IN FEET BEARINGS ARE MAGNETIC

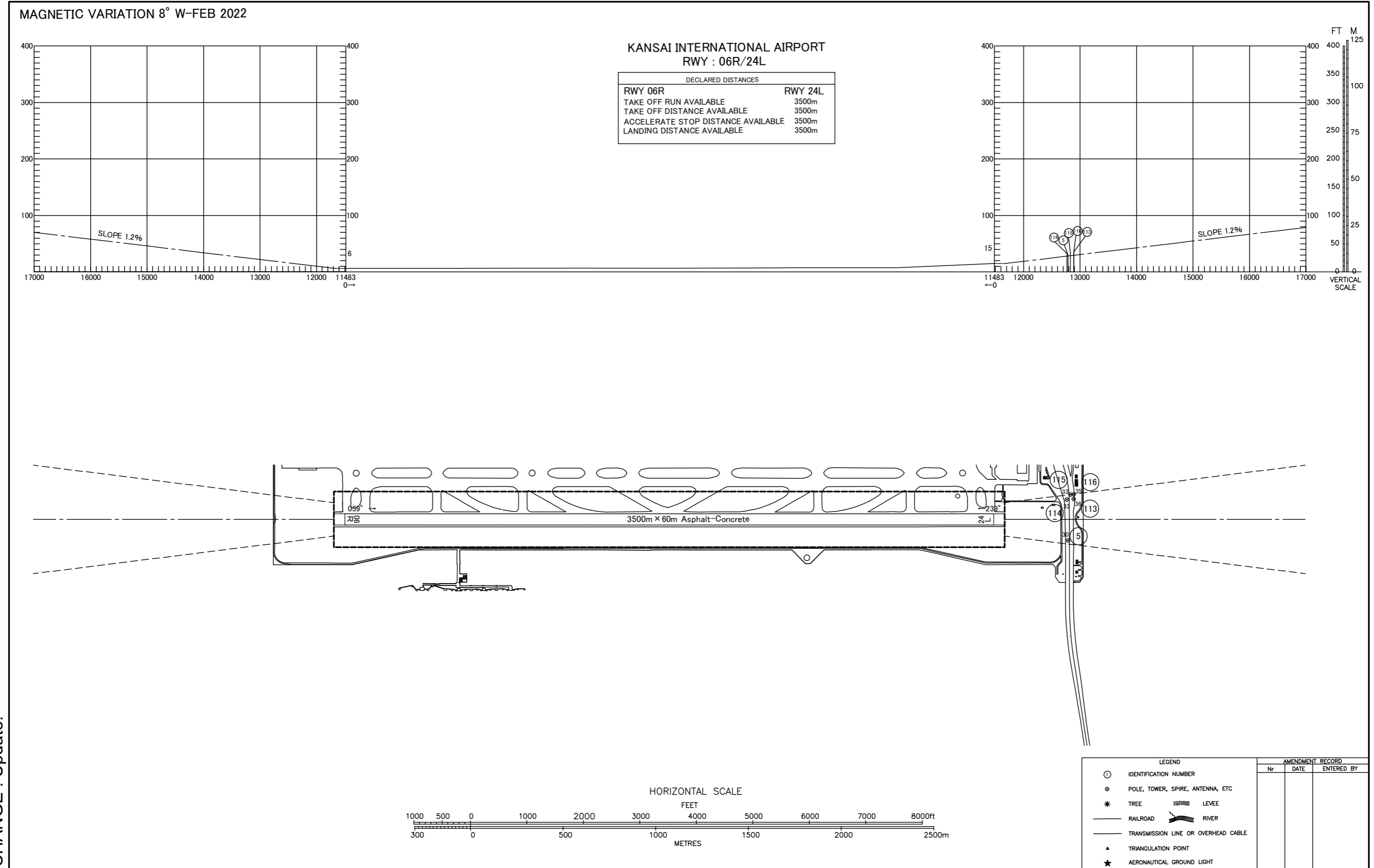

CHANGE : Update.

AERODROME OBSTACLE CHART-ICAO TYPE A (OPERATIONAL LIMITATIONS)

DIMENSIONS AND ELEVATIONS IN FEET BEARINGS ARE MAGNETIC

MAGNETIC VARIATION 8°W-FEB 2022

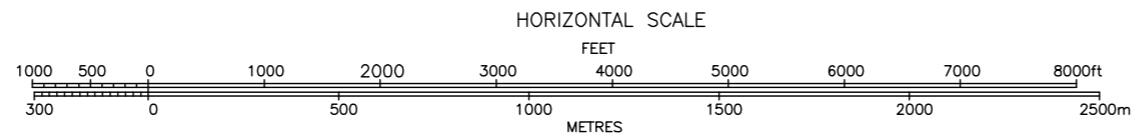
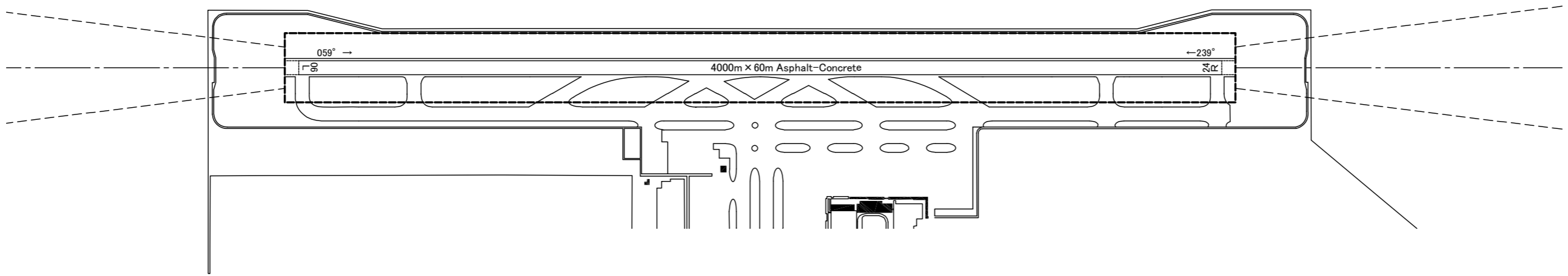
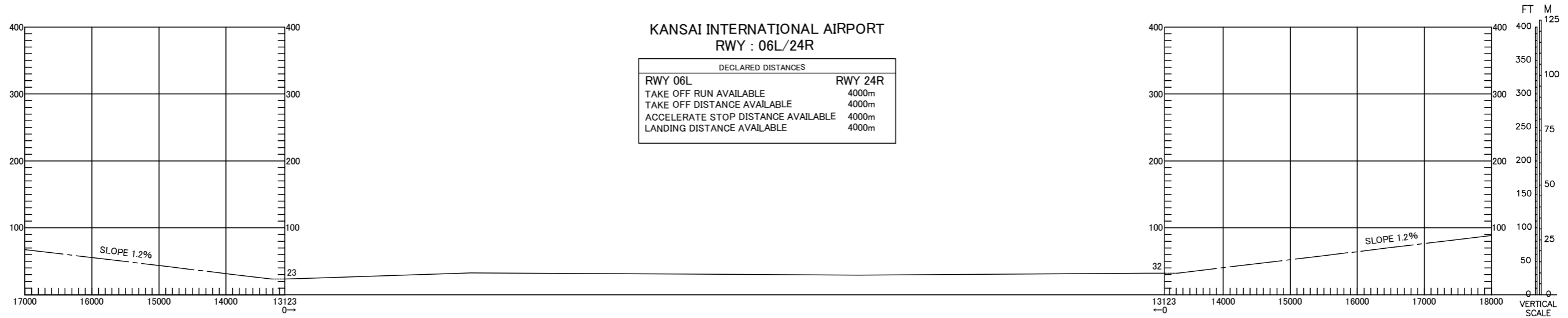

LEGEND		AMENDMENT RECORD		
		Nr	DATE	ENTERED BY
○	IDENTIFICATION NUMBER			
⊙	POLE, TOWER, SPIRE, ANTENNA, ETC			
*	TREE			
—	RAILROAD			
—	TRANSMISSION LINE OR OVERHEAD CABLE			
▲	TRIANGULATION POINT			
★	AERONAUTICAL GROUND LIGHT			
▬	LEVEE			
—	RIVER			

CHANGE : Update.

AERODROME OBSTRUCTION CHART
TYPE B

DIMENSIONS AND ELEVATIONS IN FEET BEARINGS ARE MAGNETICS

AERODROME ELEVATION 17.4ft ARP

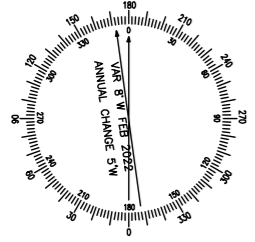
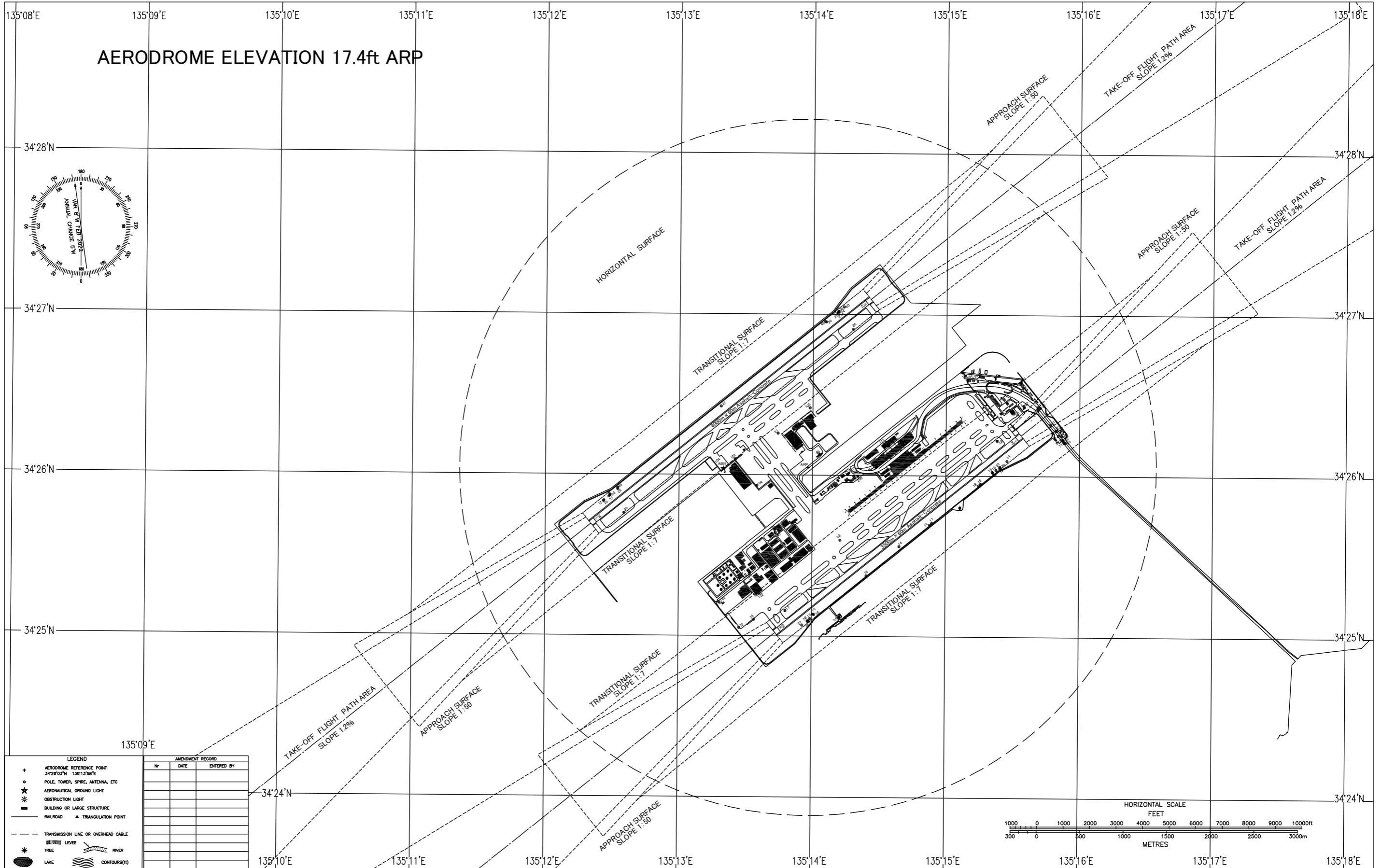

CHANGE : Update.

LEGEND		AMENDMENT RECORD		
		№	DATE	ENTERED BY
+	AERODROME REFERENCE POINT 34°28'03"N 135°13'58"E			
•	POLE, TOWER, SPIRE, ANTENNA, ETC			
★	AERONAUTICAL GROUND LIGHT			
✱	OBSTRUCTION LIGHT			
■	BUILDING OR LARGE STRUCTURE			
—	RAILROAD ▲ TRIANGULATION POINT			
---	TRANSMISSION LINE OR OVERHEAD CABLE			
—	LEVEE			
⊙	TREE			
—	RIVER			
○	LAKE			
—	CONTOURS(1)			

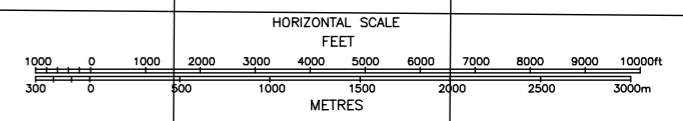

PRECISION APPROACH TERRAIN PROFILE CHART

DISTANCES AND HEIGHTS IN METERS

RWY 06R

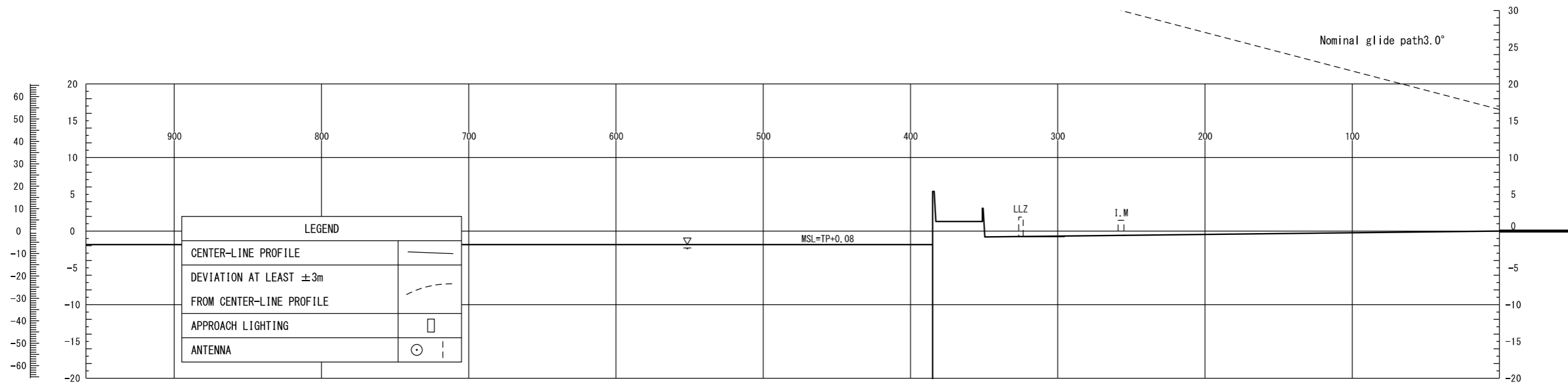
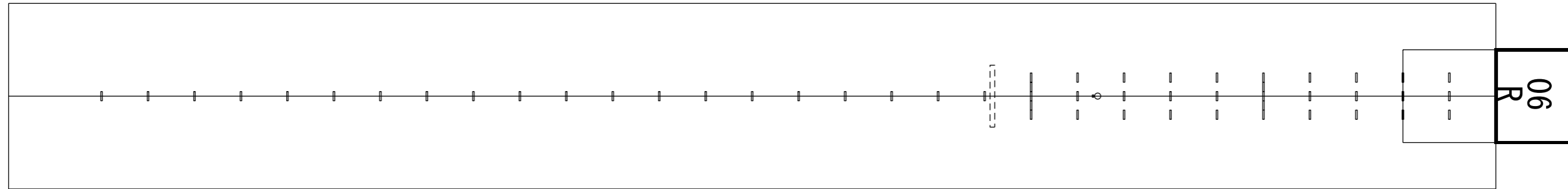

Vertical scale
in feet

HORIZONTAL SCALE 1:2500

VERTICAL SCALE 1:500

CONTOUR AND HEIGHTS ARE RELATED
TO ELEVATION OF RWY THR

CHANGE : Update.

PRECISION APPROACH TERRAIN PROFILE CHART

DISTANCES AND HEIGHTS IN METERS
RWY 24L

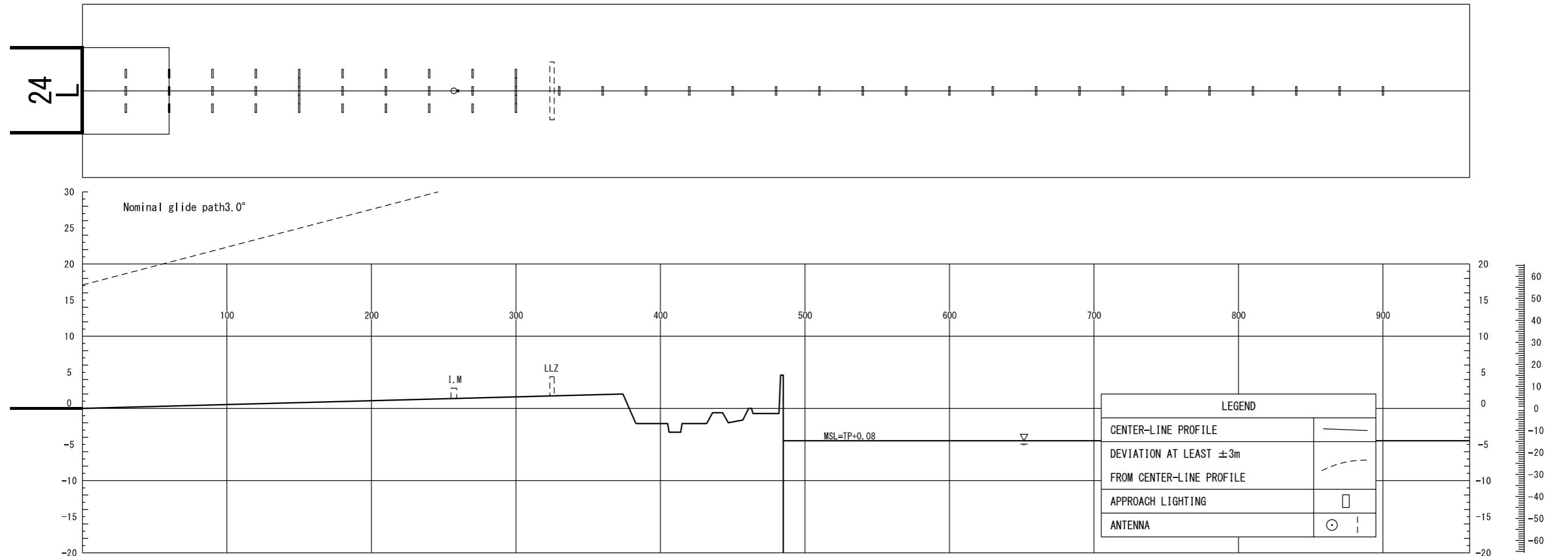

HORIZONTAL SCALE 1:2500
VERTICAL SCALE 1:500

CONTOUR AND HEIGHTS ARE RELATED
TO ELEVATION OF RWY THR

Vertical scale
in feet

CHANGE : Update.

PRECISION APPROACH TERRAIN PROFILE CHART

DISTANCES AND HEIGHTS IN METERS

RWY 06L

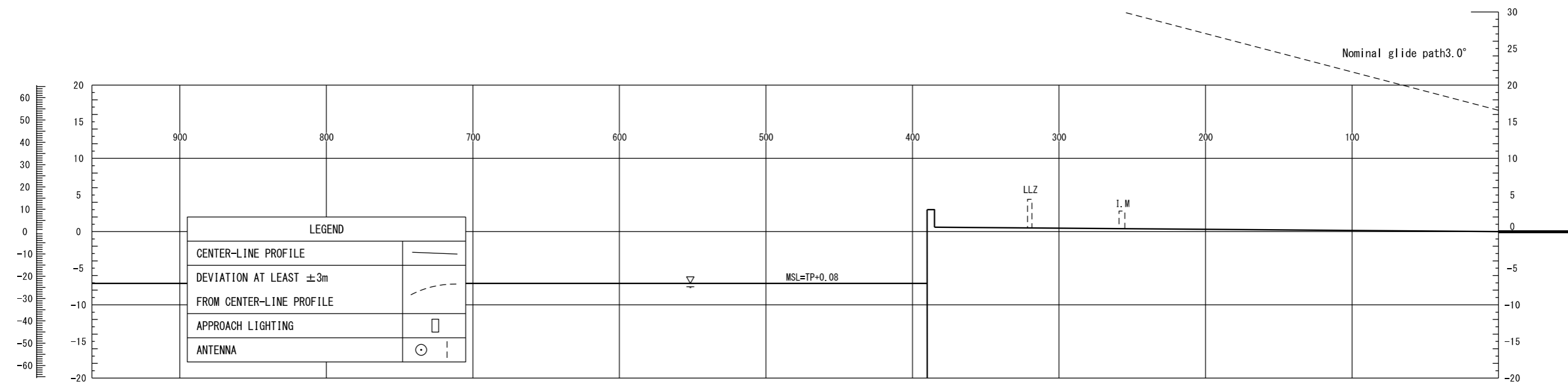
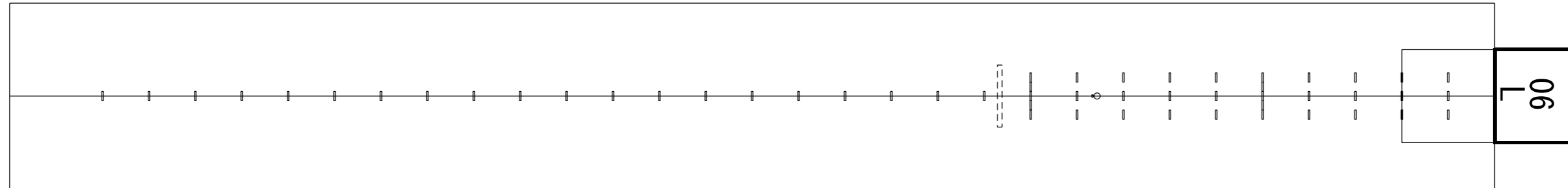

LEGEND	
CENTER-LINE PROFILE	—
DEVIATION AT LEAST ±3m FROM CENTER-LINE PROFILE	- - -
APPROACH LIGHTING	□
ANTENNA	⊙

Vertical scale in feet

HORIZONTAL SCALE 1:2500
VERTICAL SCALE 1:500

CONTOUR AND HEIGHTS ARE RELATED TO ELEVATION OF RWY THR

CHANGE : Update.

PRECISION APPROACH TERRAIN PROFILE CHART

DISTANCES AND HEIGHTS IN METERS
RWY 24R

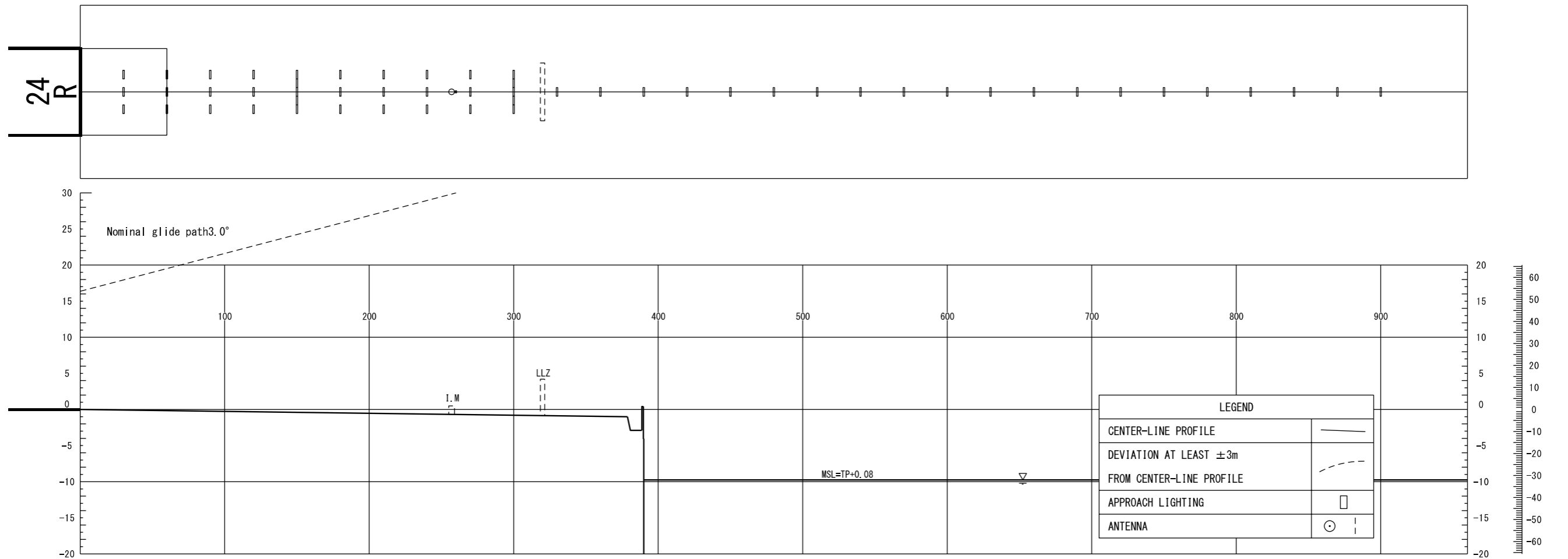

HORIZONTAL SCALE 1:2500
VERTICAL SCALE 1:500

CONTOUR AND HEIGHTS ARE RELATED
TO ELEVATION OF RWY THR

Vertical scale
in feet

CHANGE : Update.

STANDARD DEPARTURE CHART-INSTRUMENT

RJBB / KANSAI INTL

SID

MAIKO NINE DEPARTURE

RWY06R : Climb on HDG054° to KIE 5.4DME, turn left, via KCE R167 to intercept and proceed via YOE R279 to MAIKO.

Cross KIE R049 at or above 2500FT,...

RWY06L : Turn left, climb on HDG289° to intercept and proceed via KIE R334, via YOE R279 to MAIKO,...

RWY24R : Turn right, climb on HDG019° to intercept and proceed via KIE R334, via YOE R279 to MAIKO,...

RWY24L : Climb on HDG244° to KIE 5.6DME, turn right, via KCE R221 to intercept and proceed via KIE R334, via YOE R279 to MAIKO,...

...cross MAIKO at or above 5000FT.

CHANGE : Description of PROC name.

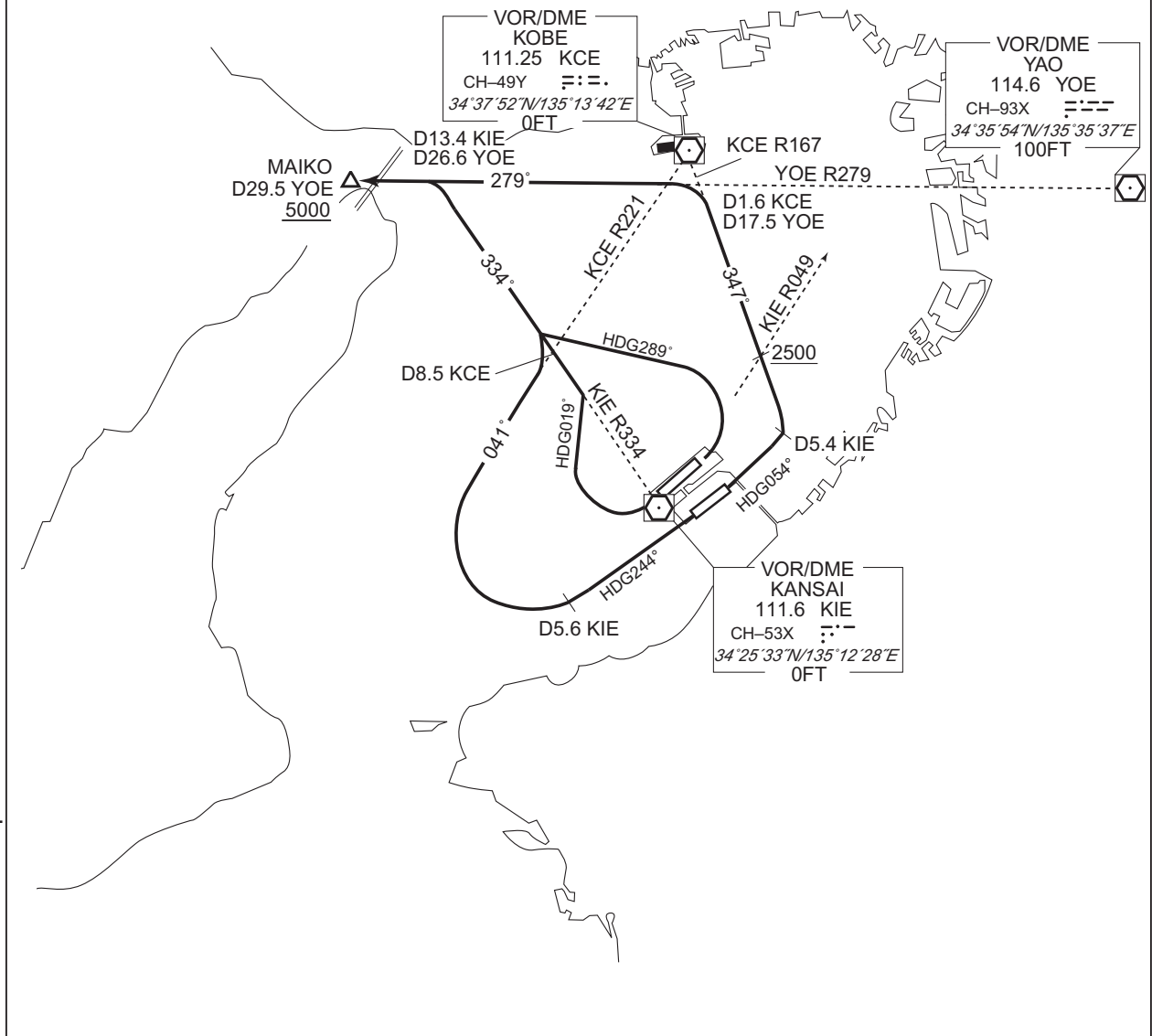

STANDARD DEPARTURE CHART-INSTRUMENT

RJBB / KANSAI INTL

SID

FERRY SIX DEPARTURE

RWY24R : Turn right, climb on HDG019° to intercept and proceed via KIE R334, via YOE R279 to MAIKO.

RWY24L : Climb RWY HDG to 500FT, turn right HDG019° to intercept and proceed via KIE R334, via YOE R279 to MAIKO.

Note RWY24L : No turn before DER.

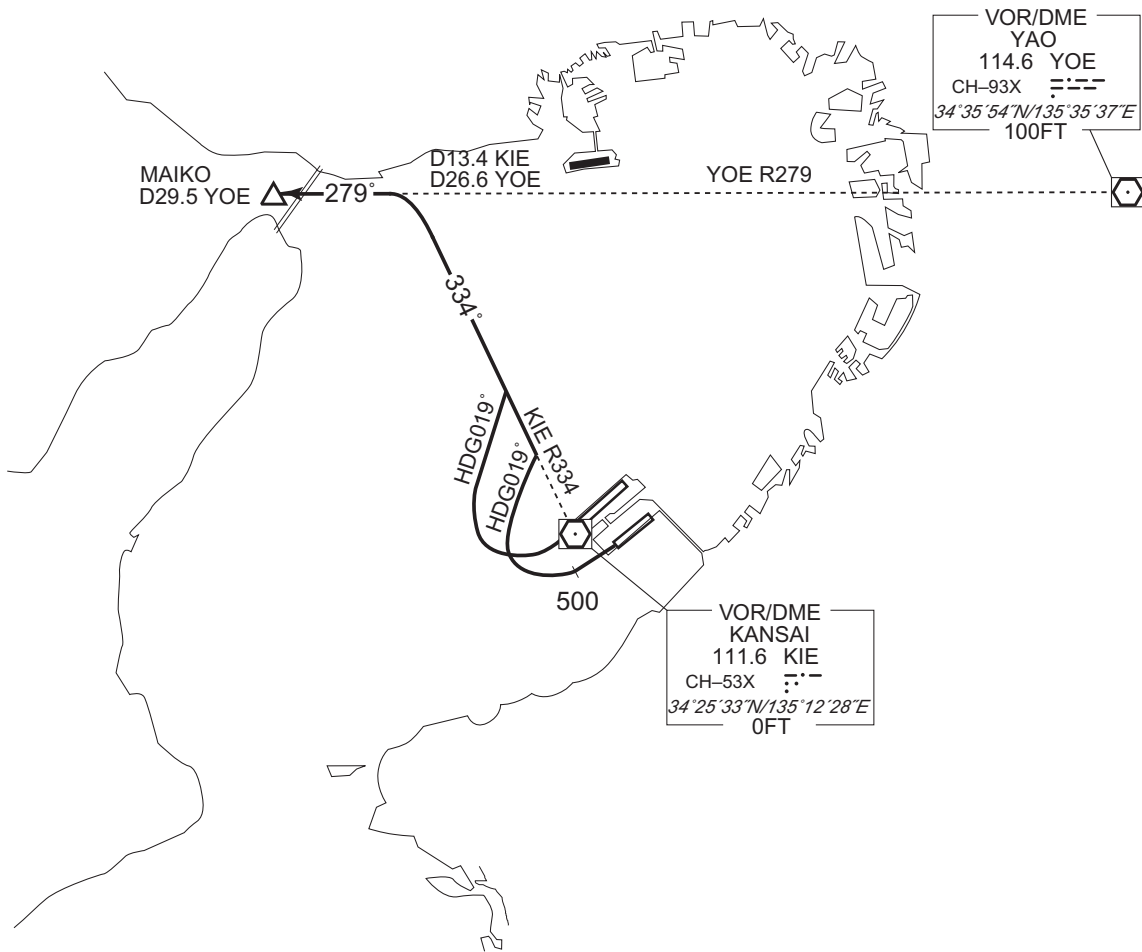

CHANGE : Description of PROC name.

STANDARD DEPARTURE CHART-INSTRUMENT

RJBB / KANSAI INTL

TRANSITION

MIYAZU TRANSITION

From over MAIKO, proceed via KCE R272 to KAWAT, via TSC R001 to CHIZU via AYAYA, via YME R236 to YME VOR/DME.
Cross KAWAT at or above 8000FT.

KIBI TRANSITION

From over MAIKO, proceed via KCE R272 to KAWAT, via OYE R114 to OYE VOR/DME.
Cross KAWAT at or above 8000FT.

KAGAWA NORTH TRANSITION

From over MAIKO, proceed via KCE R272 to KAWAT, via KTE R058 to KTE VOR/DME.
Cross KAWAT at or above 8000FT.

CHANGE : Radial FM KCE. AYAYA established.

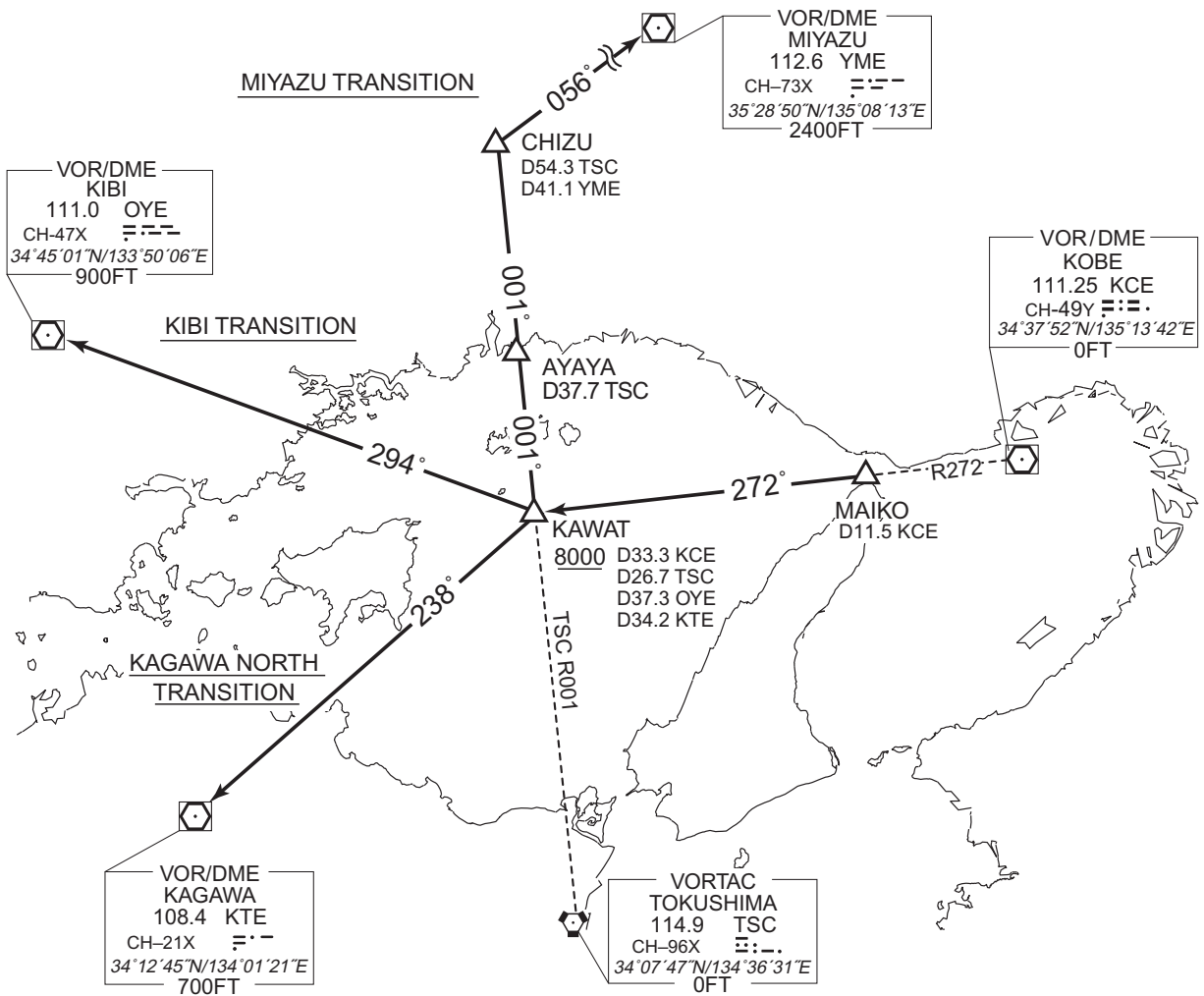

STANDARD DEPARTURE CHART-INSTRUMENT

RJBB / KANSAI INTL

SID

TOMOH WEST ONE DEPARTURE

RWY24R/L : Turn right, climb on HDG270° to intercept and proceed via KCE R215 to TOMOH.

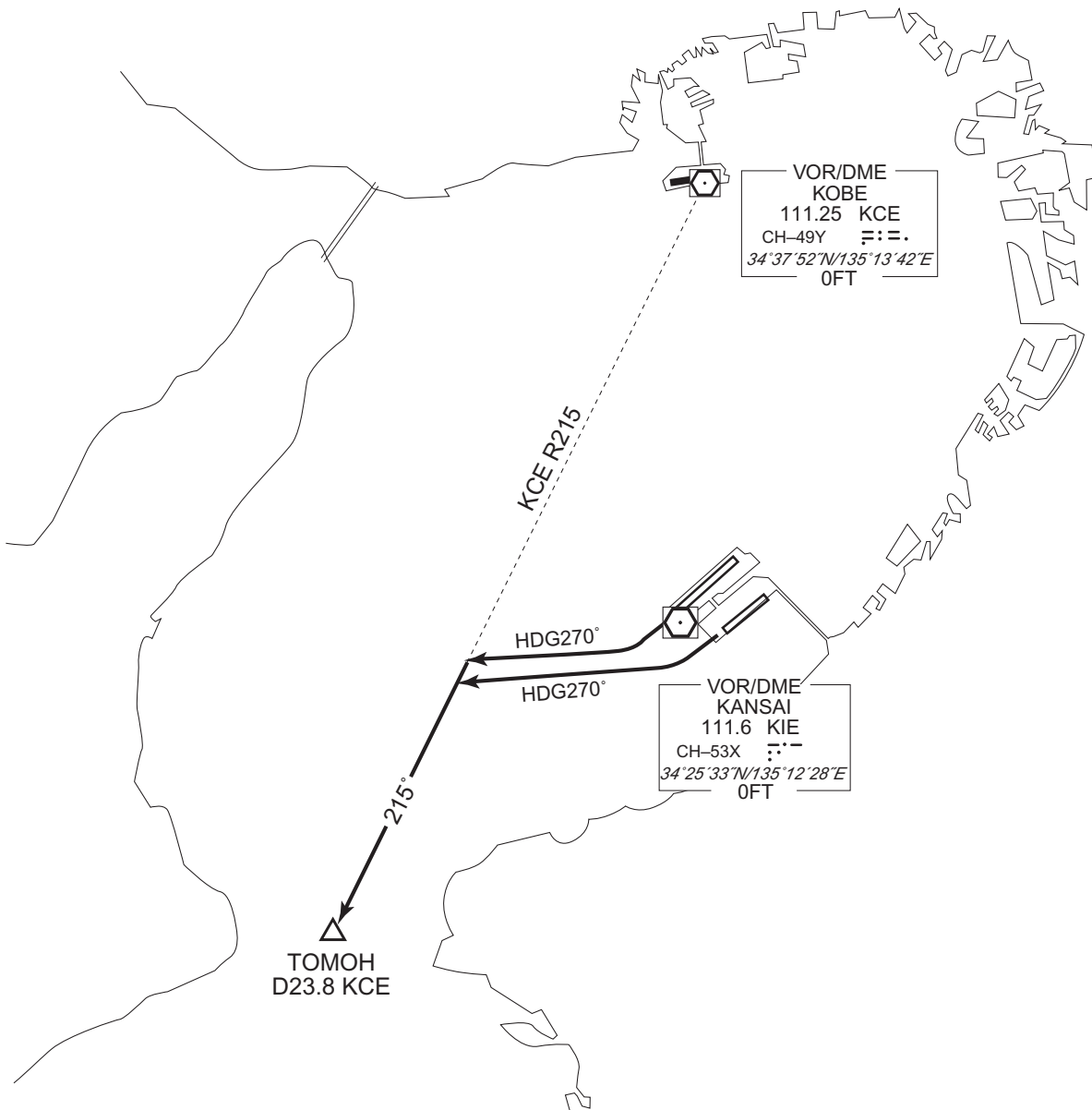

CHANGE : Description of PROC name.

STANDARD DEPARTURE CHART-INSTRUMENT

RJBB / KANSAI INTL

SID

TOMOH THREE DEPARTURE

- RWY06R : Climb on HDG054° to KIE 5.4DME, turn left, via KCE R167 to intercept and proceed via YOE R269, via KCE R215 to TOMOH.
Cross KIE R049 at or above 2500FT. ...
- RWY06L : Turn left, climb on HDG270° to intercept and proceed via KCE R215 to TOMOH. ...
- RWY24R : Turn right, climb on HDG270° to intercept and proceed via KCE R215 to TOMOH. ...
- RWY24L : Climb on HDG244° to KIE 5.6DME, turn right HDG270° to intercept and proceed via KCE R215 to TOMOH. ...

...Cross TOMOH at or above 4000FT.

CHANGE : Description of PROC name.

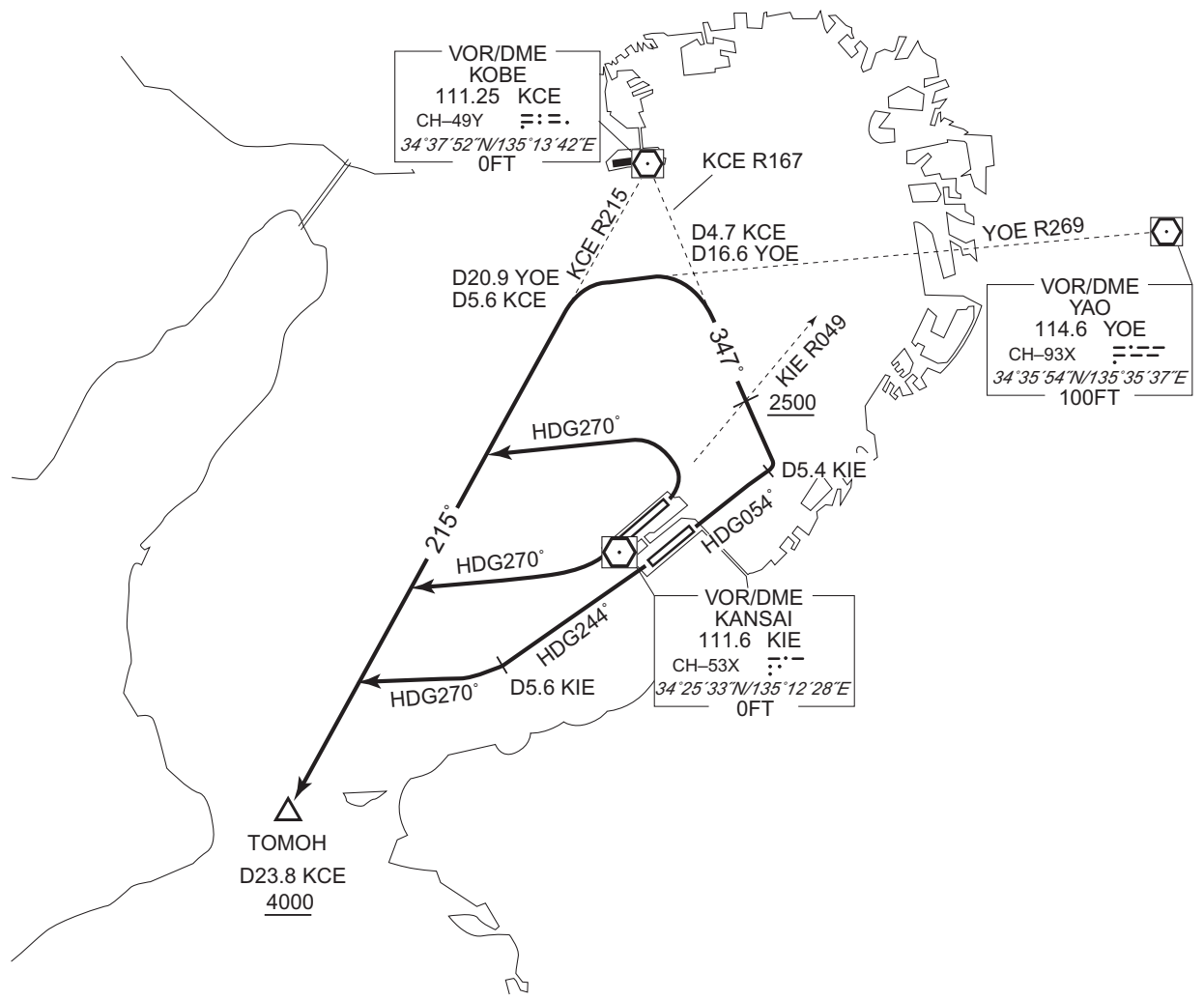

STANDARD DEPARTURE CHART-INSTRUMENT

RJBB / KANSAI INTL

TRANSITION

KOCHI SOUTH TRANSITION

From over TOMOH, proceed via KIE R237 to DIODE, via KRE R068 to KRE VOR/DME.

Cross DIODE at or above FL140.

KUSHIMOTO TRANSITION

From over TOMOH, proceed via KCE R215 to intercept and proceed via TSC R124 to GOBOH, via KEC R316 to KEC VORTAC.

Cross GOBOH at or above 6000FT.

CHANGE : KOCHI SOUTH TRANSITION. KANSAI VOR/DME updated(KNE→KIE).

STANDARD DEPARTURE CHART-INSTRUMENT

RJBB / KANSAI INTL

TRANSITION

CHANGE : Correction of misdescription(ALT restriction at DIODE).

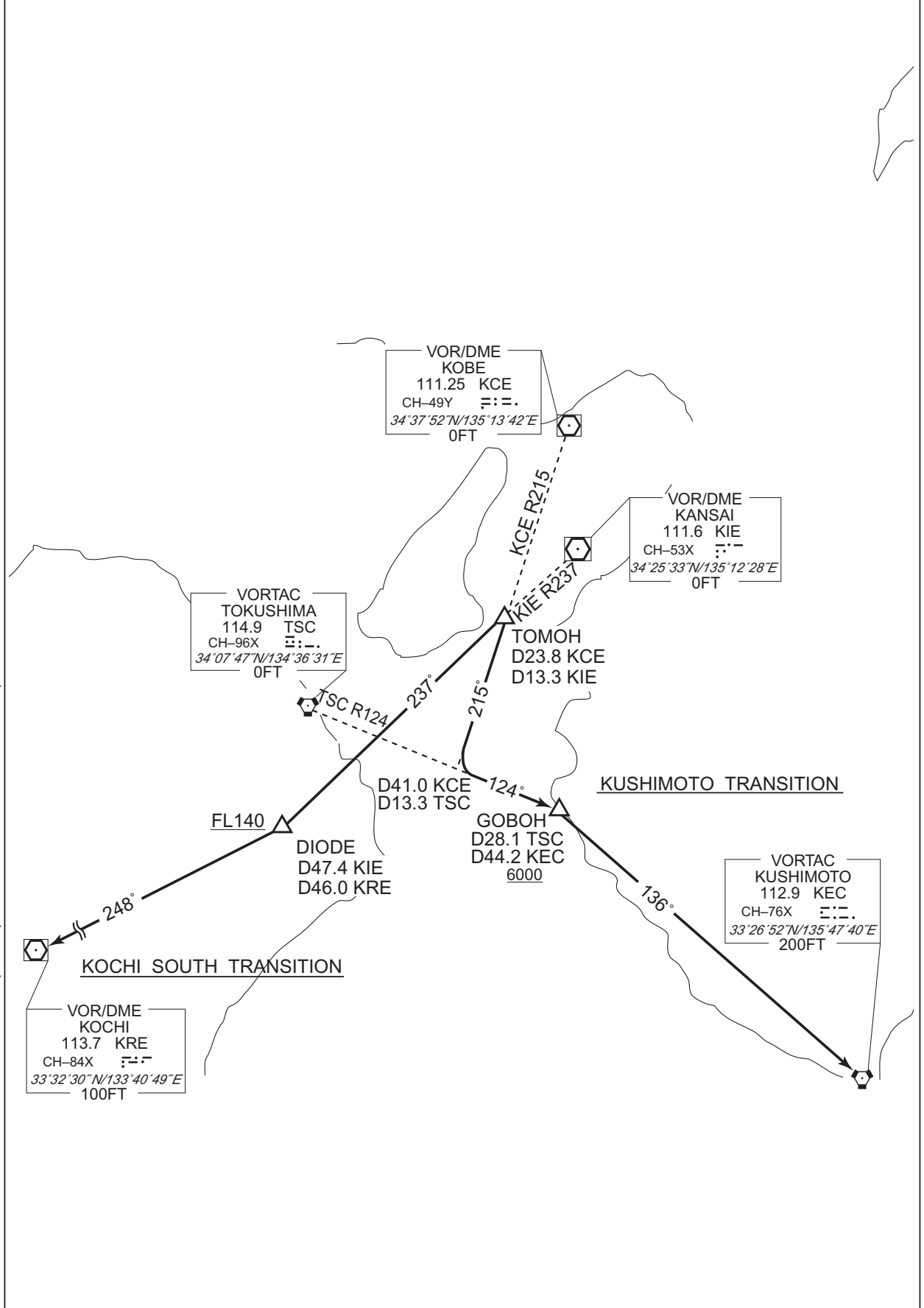

STANDARD DEPARTURE CHART - INSTRUMENT

RJBB / KANSAI INTL

RNAV SID

KITAN TWO DEPARTURE	RNAV1
---------------------	-------

Note 1) DME/DME/IRU or GNSS required. ※ The aircraft equipped with only DME/DME/IRU must be able to update its position without delay at the starting point of take-off roll. 2) RADAR service required.	Critical DME	-
	DME GAP	-
	Inappropriate Nav aids	See AD1.1.6.10.3. Inappropriate NAVAIDs for RNAV1

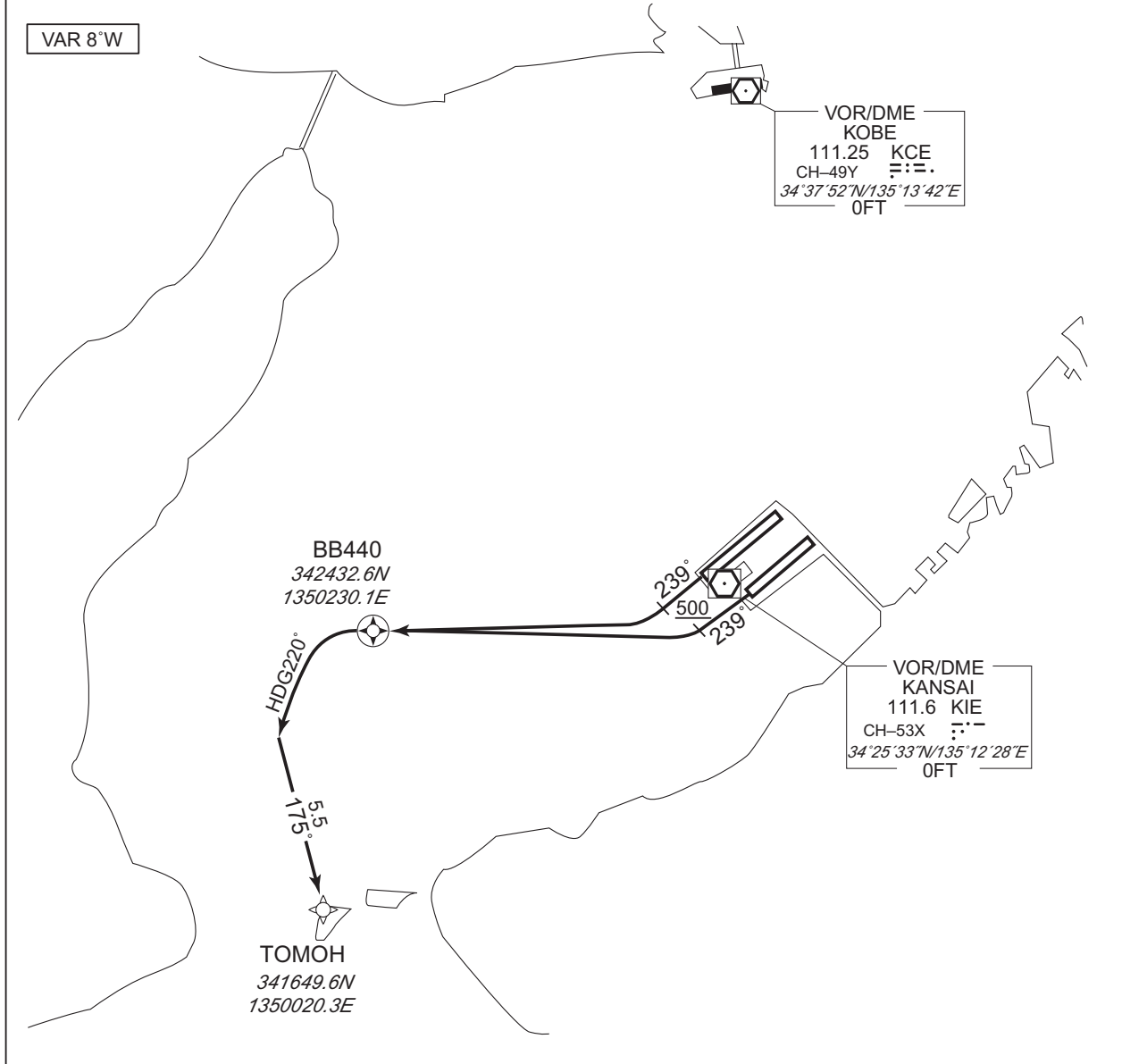

CHANGE : Description of VAR and PROC name.

RWY24R : Climb on HDG239° at or above 500FT, turn right direct to BB440, turn left HDG220°, to TOMOH on course 175°.

RWY24L : Climb on HDG239° at or above 500FT, turn right direct to BB440, turn left HDG220°, to TOMOH on course 175°.

Note RWY24L : No turn before DER.

STANDARD DEPARTURE CHART - INSTRUMENT

RJBB / KANSAI INTL

RNAV SID

KITAN TWO DEPARTURE

RWY24R

Serial Number	Path Descriptor	Waypoint Identifier	Fly Over	Course °M(°T)	Magnetic Variation	Distance (NM)	Turn Direction	Altitude (FT)	Speed (KIAS)	Vertical Angle	Navigation Specification
001	VA	-	-	239 (230.9)	-7.9	-	-	+500	-	-	RNAV1
002	DF	BB440	Y	-	-7.9	-	R	-	-	-	RNAV1
003	VI	-	-	220 (211.8)	-7.9	-	L	-	-	-	RNAV1
004	CF	TOMOH	-	175 (166.8)	-7.9	5.5	-	-	-	-	RNAV1

RWY24L

Serial Number	Path Descriptor	Waypoint Identifier	Fly Over	Course °M(°T)	Magnetic Variation	Distance (NM)	Turn Direction	Altitude (FT)	Speed (KIAS)	Vertical Angle	Navigation Specification
001	VA	-	-	239 (230.9)	-7.9	-	-	+500	-	-	RNAV1
002	DF	BB440	Y	-	-7.9	-	R	-	-	-	RNAV1
003	VI	-	-	220 (211.8)	-7.9	-	L	-	-	-	RNAV1
004	CF	TOMOH	-	175 (166.8)	-7.9	5.5	-	-	-	-	RNAV1

CHANGE : VAR. PROC renamed. PROC course.

STANDARD DEPARTURE CHART - INSTRUMENT

RJBB / KANSAI INTL

RNAV SID

SUSAN TWO DEPARTURE		RNAV1
Note 1) DME/DME/IRU or GNSS required. ※ The aircraft equipped with only DME/DME/IRU must be able to update its position without delay at the starting point of take-off roll. 2) RADAR service required.	Critical DME	—
	DME GAP	—
	Inappropriate Nav aids	See AD1.1.6.10.3. Inappropriate NAVAIDs for RNAV1

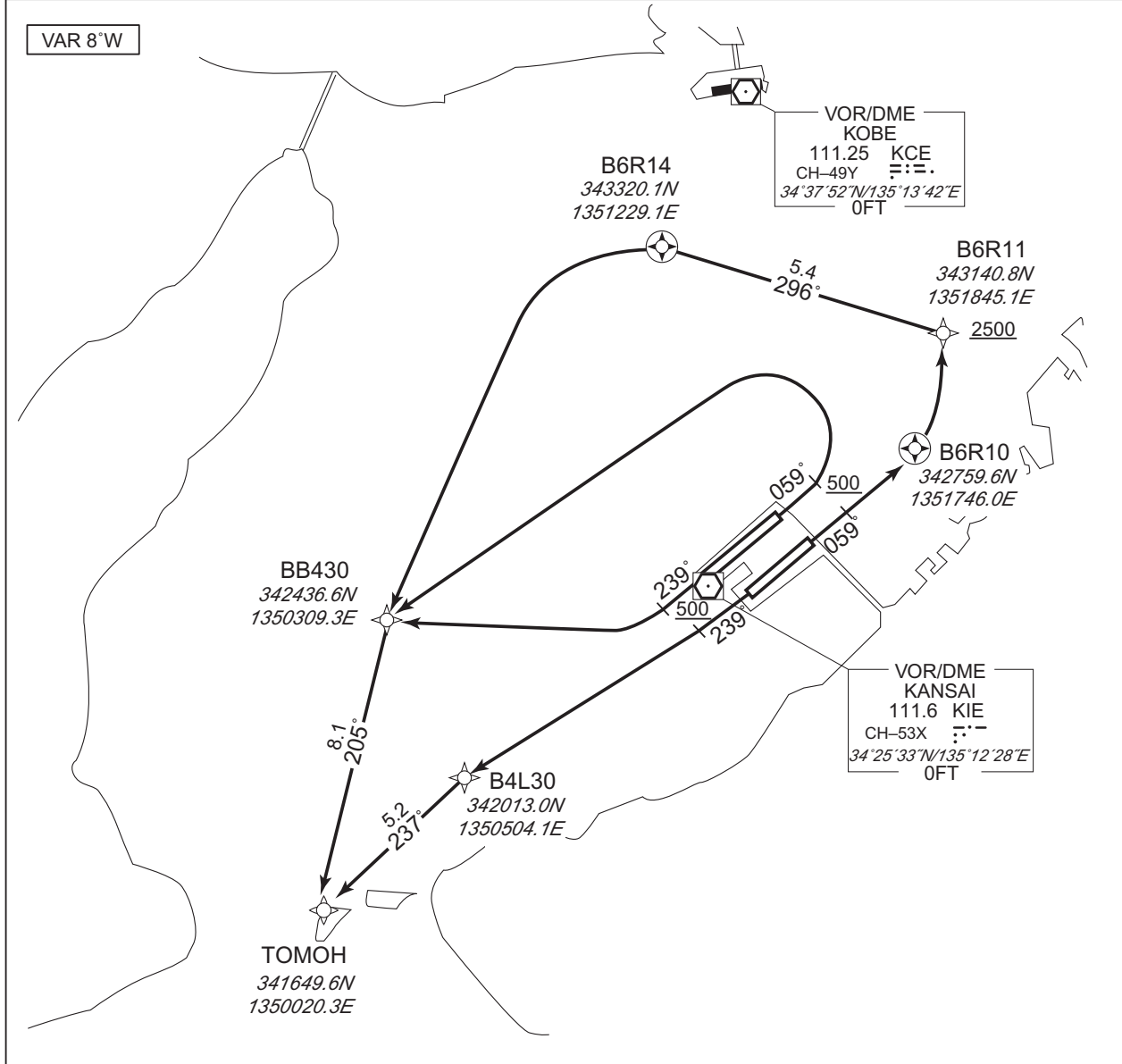

CHANGE : Description of VAR and PROC name.

RWY06R : Climb on HDG059° at or above 500FT, direct to B6R10, turn left direct to B6R11 at or above 2500FT, to B6R14, turn left direct to BB430, to TOMOH.

RWY06L : Climb on HDG059° at or above 500FT, turn left direct to BB430, to TOMOH.

RWY24R : Climb on HDG239° at or above 500FT, turn right direct to BB430, to TOMOH.

RWY24L : Climb on HDG239° at or above 500FT, direct to B4L30, to TOMOH.

STANDARD DEPARTURE CHART - INSTRUMENT

RJBB / KANSAI INTL

RNAV SID

SUSAN TWO DEPARTURE

RWY06R

Serial Number	Path Descriptor	Waypoint Identifier	Fly Over	Course °M(°T)	Magnetic Variation	Distance (NM)	Turn Direction	Altitude (FT)	Speed (KIAS)	Vertical Angle	Navigation Specification
001	VA	-	-	059 (050.9)	-7.9	-	-	+500	-	-	RNAV1
002	DF	B6R10	Y	-	-7.9	-	-	-	-	-	RNAV1
003	DF	B6R11	-	-	-7.9	-	L	+2500	-	-	RNAV1
004	TF	B6R14	Y	296 (287.8)	-7.9	5.4	-	-	-	-	RNAV1
005	DF	BB430	-	-	-7.9	-	L	-	-	-	RNAV1
006	TF	TOMOH	-	205 (196.6)	-7.9	8.1	-	-	-	-	RNAV1

RWY06L

Serial Number	Path Descriptor	Waypoint Identifier	Fly Over	Course °M(°T)	Magnetic Variation	Distance (NM)	Turn Direction	Altitude (FT)	Speed (KIAS)	Vertical Angle	Navigation Specification
001	VA	-	-	059 (050.9)	-7.9	-	-	+500	-	-	RNAV1
002	DF	BB430	-	-	-7.9	-	L	-	-	-	RNAV1
003	TF	TOMOH	-	205 (196.6)	-7.9	8.1	-	-	-	-	RNAV1

RWY24R

Serial Number	Path Descriptor	Waypoint Identifier	Fly Over	Course °M(°T)	Magnetic Variation	Distance (NM)	Turn Direction	Altitude (FT)	Speed (KIAS)	Vertical Angle	Navigation Specification
001	VA	-	-	239 (230.9)	-7.9	-	-	+500	-	-	RNAV1
002	DF	BB430	-	-	-7.9	-	R	-	-	-	RNAV1
003	TF	TOMOH	-	205 (196.6)	-7.9	8.1	-	-	-	-	RNAV1

RWY24L

Serial Number	Path Descriptor	Waypoint Identifier	Fly Over	Course °M(°T)	Magnetic Variation	Distance (NM)	Turn Direction	Altitude (FT)	Speed (KIAS)	Vertical Angle	Navigation Specification
001	VA	-	-	239 (230.9)	-7.9	-	-	+500	-	-	RNAV1
002	DF	B4L30	-	-	-7.9	-	-	-	-	-	RNAV1
003	TF	TOMOH	-	237 (229.1)	-7.9	5.2	-	-	-	-	RNAV1

CHANGE : VAR. PROC renamed. PROC course.

STANDARD DEPARTURE CHART - INSTRUMENT

RJBB / KANSAI INTL

RNAV TRANSITION

TONDA TRANSITION / YOSAK TRANSITION	RNAV1
-------------------------------------	-------

Note 1) DME/DME/IRU or GNSS required. 2) RADAR service required.

Inappropriate Nav aids

See AD1.1.6.10.3. Inappropriate NAV AIDs for RNAV1

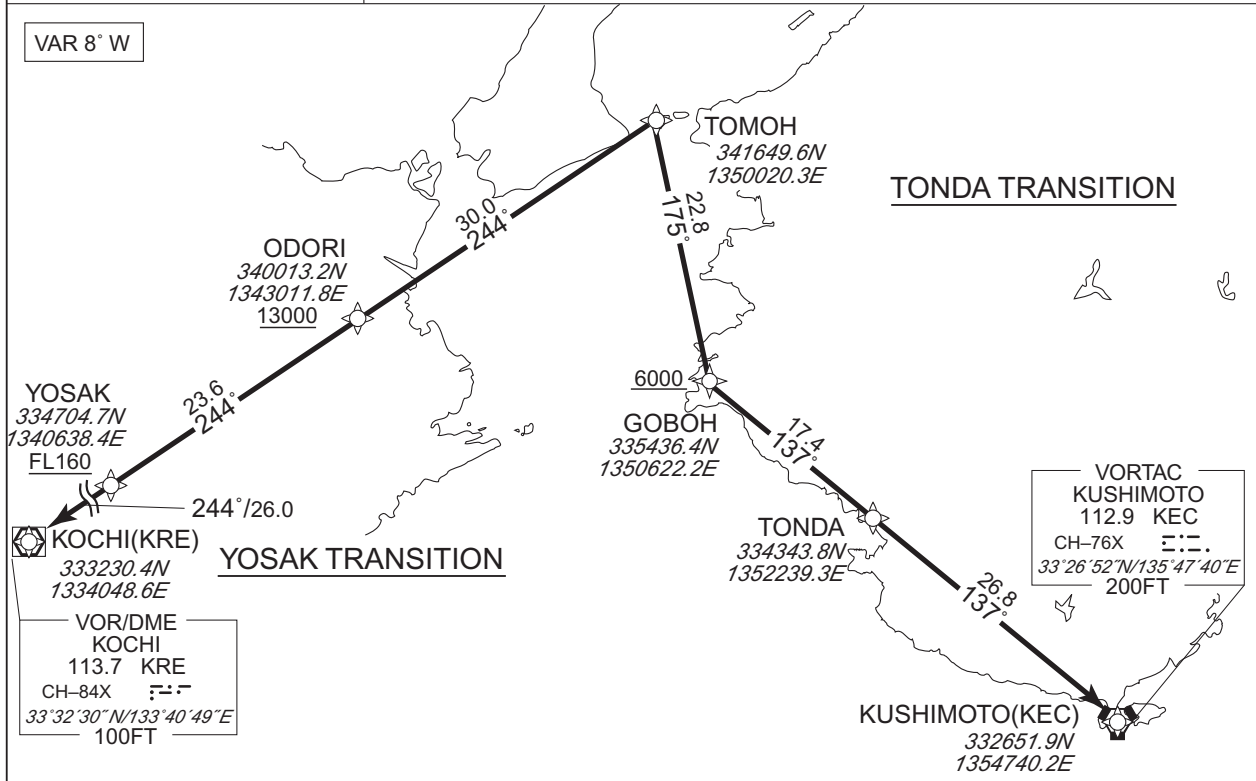

TONDA TRANSITION

From TOMOH, to GOBOH at or above 6000FT, to TONDA, to KEC.

Critical DME	YME : TOMOH - 20.0NM to GOBOH GBD : 10.0NM to GOBOH - 4.0NM to GOBOH
DME GAP	3.0NM to GOBOH - 10.0NM to TONDA 7.0NM to KEC - KEC

CHANGE : Description of VAR.

Serial Number	Path Descriptor	Waypoint Identifier	Fly Over	Course °M(°T)	Magnetic Variation	Distance (NM)	Turn Direction	Altitude (FT)	Speed (KIAS)	Vertical Angle	Navigation Specification
001	IF	TOMOH	-	-	-7.9	-	-	-	-	-	RNAV1
002	TF	GOBOH	-	175 (167.3)	-7.9	22.8	-	+6000	-	-	RNAV1
003	TF	TONDA	-	137 (128.7)	-7.9	17.4	-	-	-	-	RNAV1
004	TF	KEC	-	137 (128.9)	-7.9	26.8	-	-	-	-	RNAV1

STANDARD DEPARTURE CHART - INSTRUMENT

RJBB / KANSAI INTL

RNAV TRANSITION

YOSAK TRANSITION

From TOMOH, to ODORI at or above 13000FT, to YOSAK at or above FL160, to KRE.

Critical DME	-
DME GAP	-

Serial Number	Path Descriptor	Waypoint Identifier	Fly Over	Course °M(°T)	Magnetic Variation	Distance (NM)	Turn Direction	Altitude (FT)	Speed (KIAS)	Vertical Angle	Navigation Specification
001	IF	TOMOH	-	-	-7.9	-	-	-	-	-	RNAV1
002	TF	ODORI	-	244 (236.5)	-7.9	30.0	-	+13000	-	-	RNAV1
003	TF	YOSAK	-	244 (236.2)	-7.9	23.6	-	+FL160	-	-	RNAV1
004	TF	KRE	-	244 (236.0)	-7.9	26.0	-	-	-	-	RNAV1

CHANGE : VAR.

STANDARD DEPARTURE CHART - INSTRUMENT

RJBB / KANSAI INTL

RNAV SID

ISPUM ONE DEPARTURE		RNAV1
Note 1) DME/DME/IRU or GNSS required. ※ The aircraft equipped with only DME/DME/IRU must be able to update its position without delay at the starting point of take-off roll. 2) RADAR service required.	Critical DME	-
	DME GAP	-
	Inappropriate NavAids	See AD1.1.6.10.3. Inappropriate NAVAIDs for RNAV1

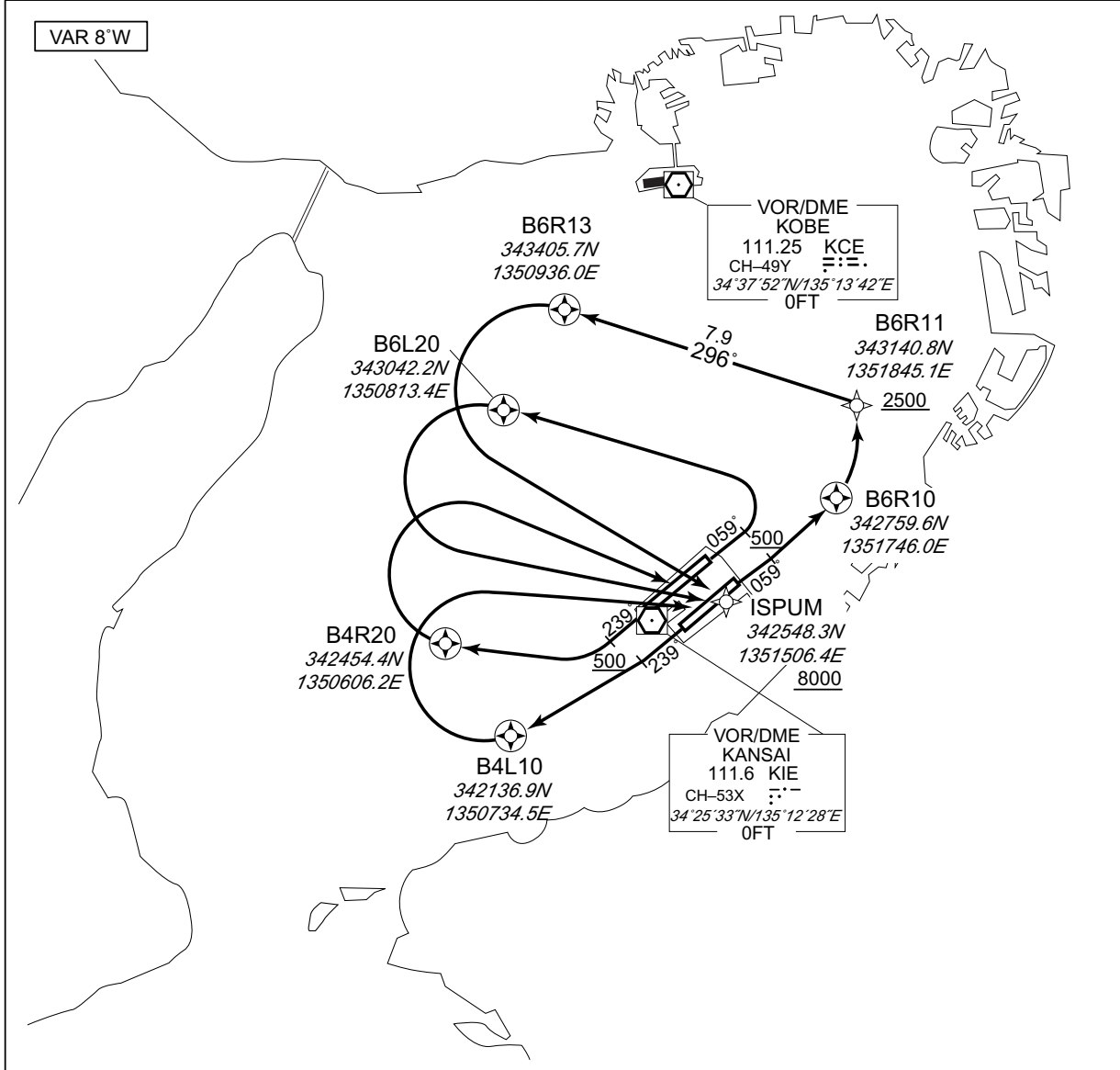

CHANGE : Description of VAR and PROC name.

RWY06R : Climb on HDG059° at or above 500FT, direct to B6R10, turn left direct to B6R11 at or above 2500FT, to B6R13, turn left direct to ISPUM at or above 8000FT.

RWY06L : Climb on HDG059° at or above 500FT, turn left direct to B6L20, turn left direct to ISPUM at or above 8000FT.

RWY24R : Climb on HDG239° at or above 500FT, turn right direct to B4R20, turn right direct to ISPUM at or above 8000FT.

RWY24L : Climb on HDG239° at or above 500FT, direct to B4L10, turn right direct to ISPUM at or above 8000FT.

STANDARD DEPARTURE CHART - INSTRUMENT

RJBB / KANSAI INTL

RNAV SID

ISPUM ONE DEPARTURE

RWY06R

Serial Number	Path Descriptor	Waypoint Identifier	Fly Over	Course °M(°T)	Magnetic Variation	Distance (NM)	Turn Direction	Altitude (FT)	Speed (KIAS)	Vertical Angle	Navigation Specification
001	VA	-	-	059 (050.9)	-7.9	-	-	+500	-	-	RNAV1
002	DF	B6R10	Y	-	-7.9	-	-	-	-	-	RNAV1
003	DF	B6R11	-	-	-7.9	-	L	+2500	-	-	RNAV1
004	TF	B6R13	Y	296 (287.8)	-7.9	7.9	-	-	-	-	RNAV1
005	DF	ISPUM	-	-	-7.9	-	L	+8000	-	-	RNAV1

RWY06L

Serial Number	Path Descriptor	Waypoint Identifier	Fly Over	Course °M(°T)	Magnetic Variation	Distance (NM)	Turn Direction	Altitude (FT)	Speed (KIAS)	Vertical Angle	Navigation Specification
001	VA	-	-	059 (050.9)	-7.9	-	-	+500	-	-	RNAV1
002	DF	B6L20	Y	-	-7.9	-	L	-	-	-	RNAV1
003	DF	ISPUM	-	-	-7.9	-	L	+8000	-	-	RNAV1

RWY24R

Serial Number	Path Descriptor	Waypoint Identifier	Fly Over	Course °M(°T)	Magnetic Variation	Distance (NM)	Turn Direction	Altitude (FT)	Speed (KIAS)	Vertical Angle	Navigation Specification
001	VA	-	-	239 (230.9)	-7.9	-	-	+500	-	-	RNAV1
002	DF	B4R20	Y	-	-7.9	-	R	-	-	-	RNAV1
003	DF	ISPUM	-	-	-7.9	-	R	+8000	-	-	RNAV1

RWY24L

Serial Number	Path Descriptor	Waypoint Identifier	Fly Over	Course °M(°T)	Magnetic Variation	Distance (NM)	Turn Direction	Altitude (FT)	Speed (KIAS)	Vertical Angle	Navigation Specification
001	VA	-	-	239 (230.9)	-7.9	-	-	+500	-	-	RNAV1
002	DF	B4L10	Y	-	-7.9	-	-	-	-	-	RNAV1
003	DF	ISPUM	-	-	-7.9	-	R	+8000	-	-	RNAV1

CHANGE : New PROC.

STANDARD DEPARTURE CHART - INSTRUMENT

RJBB / KANSAI INTL

RNAV TRANSITION

BAMBI TRANSITION / SHTLE TRANSITION / UENOH TRANSITION	RNAV1																																																																
Note 1) DME/DME/IRU or GNSS required. 2) RADAR service required.																																																																	
Inappropriate NavAids	See AD1.1.6.10.3. Inappropriate NAVAIDs for RNAV1																																																																
<div style="border: 1px solid black; padding: 2px; width: fit-content; margin-bottom: 10px;">VAR 8° W</div> <p>VOR/DME KANSAI 111.6 KIE CH-53X 34°25'33"N/135°12'28"E 0FT</p> <p>ISPUM 342548.3N 1351506.4E</p> <p>NARAH 342958.8N 1354102.9E</p> <p>YAGYU 343239.3N 1355738.1E</p> <p>SHTLE 344951.0N 1365653.8E</p> <p>UENOH 345008.7N 1361333.7E</p> <p>GUJYO 352150.5N 1363438.5E</p>																																																																	
<p>BAMBI TRANSITION From ISPUM, to NARAH.</p> <table border="1" style="width:100%; border-collapse: collapse;"> <tr> <td style="width:50%;">Critical DME</td> <td style="width:50%; text-align:center;">-</td> </tr> <tr> <td>DME GAP</td> <td style="text-align:center;">-</td> </tr> </table> <table border="1" style="width:100%; border-collapse: collapse;"> <thead> <tr> <th>Serial Number</th> <th>Path Descriptor</th> <th>Waypoint Identifier</th> <th>Fly Over</th> <th>Course °M(°T)</th> <th>Magnetic Variation</th> <th>Distance (NM)</th> <th>Turn Direction</th> <th>Altitude (FT)</th> <th>Speed (KIAS)</th> <th>Vertical Angle</th> <th>Navigation Specification</th> </tr> </thead> <tbody> <tr> <td>001</td> <td>IF</td> <td>ISPUM</td> <td>-</td> <td>-</td> <td>-7.9</td> <td>-</td> <td>-</td> <td>-</td> <td>-</td> <td>-</td> <td>RNAV1</td> </tr> <tr> <td>002</td> <td>TF</td> <td>NARAH</td> <td>-</td> <td>087 (078.8)</td> <td>-7.9</td> <td>21.8</td> <td>-</td> <td>-</td> <td>-</td> <td>-</td> <td>RNAV1</td> </tr> </tbody> </table>	Critical DME	-	DME GAP	-	Serial Number	Path Descriptor	Waypoint Identifier	Fly Over	Course °M(°T)	Magnetic Variation	Distance (NM)	Turn Direction	Altitude (FT)	Speed (KIAS)	Vertical Angle	Navigation Specification	001	IF	ISPUM	-	-	-7.9	-	-	-	-	-	RNAV1	002	TF	NARAH	-	087 (078.8)	-7.9	21.8	-	-	-	-	RNAV1																									
Critical DME	-																																																																
DME GAP	-																																																																
Serial Number	Path Descriptor	Waypoint Identifier	Fly Over	Course °M(°T)	Magnetic Variation	Distance (NM)	Turn Direction	Altitude (FT)	Speed (KIAS)	Vertical Angle	Navigation Specification																																																						
001	IF	ISPUM	-	-	-7.9	-	-	-	-	-	RNAV1																																																						
002	TF	NARAH	-	087 (078.8)	-7.9	21.8	-	-	-	-	RNAV1																																																						
<p>SHTLE TRANSITION From ISPUM, to NARAH, to YAGYU, to SHTLE.</p> <table border="1" style="width:100%; border-collapse: collapse;"> <tr> <td style="width:50%;">Critical DME</td> <td style="width:50%; text-align:center;">-</td> </tr> <tr> <td>DME GAP</td> <td style="text-align:center;">-</td> </tr> </table> <table border="1" style="width:100%; border-collapse: collapse;"> <thead> <tr> <th>Serial Number</th> <th>Path Descriptor</th> <th>Waypoint Identifier</th> <th>Fly Over</th> <th>Course °M(°T)</th> <th>Magnetic Variation</th> <th>Distance (NM)</th> <th>Turn Direction</th> <th>Altitude (FT)</th> <th>Speed (KIAS)</th> <th>Vertical Angle</th> <th>Navigation Specification</th> </tr> </thead> <tbody> <tr> <td>001</td> <td>IF</td> <td>ISPUM</td> <td>-</td> <td>-</td> <td>-7.9</td> <td>-</td> <td>-</td> <td>-</td> <td>-</td> <td>-</td> <td>RNAV1</td> </tr> <tr> <td>002</td> <td>TF</td> <td>NARAH</td> <td>-</td> <td>087 (078.8)</td> <td>-7.9</td> <td>21.8</td> <td>-</td> <td>-</td> <td>-</td> <td>-</td> <td>RNAV1</td> </tr> <tr> <td>003</td> <td>TF</td> <td>YAGYU</td> <td>-</td> <td>087 (078.8)</td> <td>-7.9</td> <td>13.9</td> <td>-</td> <td>-</td> <td>-</td> <td>-</td> <td>RNAV1</td> </tr> <tr> <td>004</td> <td>TF</td> <td>SHTLE</td> <td>-</td> <td>078 (070.3)</td> <td>-7.9</td> <td>51.7</td> <td>-</td> <td>-</td> <td>-</td> <td>-</td> <td>RNAV1</td> </tr> </tbody> </table>	Critical DME	-	DME GAP	-	Serial Number	Path Descriptor	Waypoint Identifier	Fly Over	Course °M(°T)	Magnetic Variation	Distance (NM)	Turn Direction	Altitude (FT)	Speed (KIAS)	Vertical Angle	Navigation Specification	001	IF	ISPUM	-	-	-7.9	-	-	-	-	-	RNAV1	002	TF	NARAH	-	087 (078.8)	-7.9	21.8	-	-	-	-	RNAV1	003	TF	YAGYU	-	087 (078.8)	-7.9	13.9	-	-	-	-	RNAV1	004	TF	SHTLE	-	078 (070.3)	-7.9	51.7	-	-	-	-	RNAV1	
Critical DME	-																																																																
DME GAP	-																																																																
Serial Number	Path Descriptor	Waypoint Identifier	Fly Over	Course °M(°T)	Magnetic Variation	Distance (NM)	Turn Direction	Altitude (FT)	Speed (KIAS)	Vertical Angle	Navigation Specification																																																						
001	IF	ISPUM	-	-	-7.9	-	-	-	-	-	RNAV1																																																						
002	TF	NARAH	-	087 (078.8)	-7.9	21.8	-	-	-	-	RNAV1																																																						
003	TF	YAGYU	-	087 (078.8)	-7.9	13.9	-	-	-	-	RNAV1																																																						
004	TF	SHTLE	-	078 (070.3)	-7.9	51.7	-	-	-	-	RNAV1																																																						
<p>UENOH TRANSITION From ISPUM, to NARAH, to UENOH, to GUJYO.</p> <table border="1" style="width:100%; border-collapse: collapse;"> <tr> <td style="width:50%;">Critical DME</td> <td style="width:50%;">KCC : 32.0NM to GUJYO - 24.0NM to GUJYO</td> </tr> <tr> <td>DME GAP</td> <td style="text-align:center;">-</td> </tr> </table> <table border="1" style="width:100%; border-collapse: collapse;"> <thead> <tr> <th>Serial Number</th> <th>Path Descriptor</th> <th>Waypoint Identifier</th> <th>Fly Over</th> <th>Course °M(°T)</th> <th>Magnetic Variation</th> <th>Distance (NM)</th> <th>Turn Direction</th> <th>Altitude (FT)</th> <th>Speed (KIAS)</th> <th>Vertical Angle</th> <th>Navigation Specification</th> </tr> </thead> <tbody> <tr> <td>001</td> <td>IF</td> <td>ISPUM</td> <td>-</td> <td>-</td> <td>-7.9</td> <td>-</td> <td>-</td> <td>-</td> <td>-</td> <td>-</td> <td>RNAV1</td> </tr> <tr> <td>002</td> <td>TF</td> <td>NARAH</td> <td>-</td> <td>087 (078.8)</td> <td>-7.9</td> <td>21.8</td> <td>-</td> <td>-</td> <td>-</td> <td>-</td> <td>RNAV1</td> </tr> <tr> <td>003</td> <td>TF</td> <td>UENOH</td> <td>-</td> <td>061 (052.8)</td> <td>-7.9</td> <td>33.5</td> <td>-</td> <td>-</td> <td>-</td> <td>-</td> <td>RNAV1</td> </tr> <tr> <td>004</td> <td>TF</td> <td>GUJYO</td> <td>-</td> <td>036 (028.5)</td> <td>-7.9</td> <td>36.1</td> <td>-</td> <td>-</td> <td>-</td> <td>-</td> <td>RNAV1</td> </tr> </tbody> </table>	Critical DME	KCC : 32.0NM to GUJYO - 24.0NM to GUJYO	DME GAP	-	Serial Number	Path Descriptor	Waypoint Identifier	Fly Over	Course °M(°T)	Magnetic Variation	Distance (NM)	Turn Direction	Altitude (FT)	Speed (KIAS)	Vertical Angle	Navigation Specification	001	IF	ISPUM	-	-	-7.9	-	-	-	-	-	RNAV1	002	TF	NARAH	-	087 (078.8)	-7.9	21.8	-	-	-	-	RNAV1	003	TF	UENOH	-	061 (052.8)	-7.9	33.5	-	-	-	-	RNAV1	004	TF	GUJYO	-	036 (028.5)	-7.9	36.1	-	-	-	-	RNAV1	
Critical DME	KCC : 32.0NM to GUJYO - 24.0NM to GUJYO																																																																
DME GAP	-																																																																
Serial Number	Path Descriptor	Waypoint Identifier	Fly Over	Course °M(°T)	Magnetic Variation	Distance (NM)	Turn Direction	Altitude (FT)	Speed (KIAS)	Vertical Angle	Navigation Specification																																																						
001	IF	ISPUM	-	-	-7.9	-	-	-	-	-	RNAV1																																																						
002	TF	NARAH	-	087 (078.8)	-7.9	21.8	-	-	-	-	RNAV1																																																						
003	TF	UENOH	-	061 (052.8)	-7.9	33.5	-	-	-	-	RNAV1																																																						
004	TF	GUJYO	-	036 (028.5)	-7.9	36.1	-	-	-	-	RNAV1																																																						

CHANGE : Description of VAR.

STANDARD DEPARTURE CHART - INSTRUMENT

RJBB / KANSAI INTL

RNAV SID

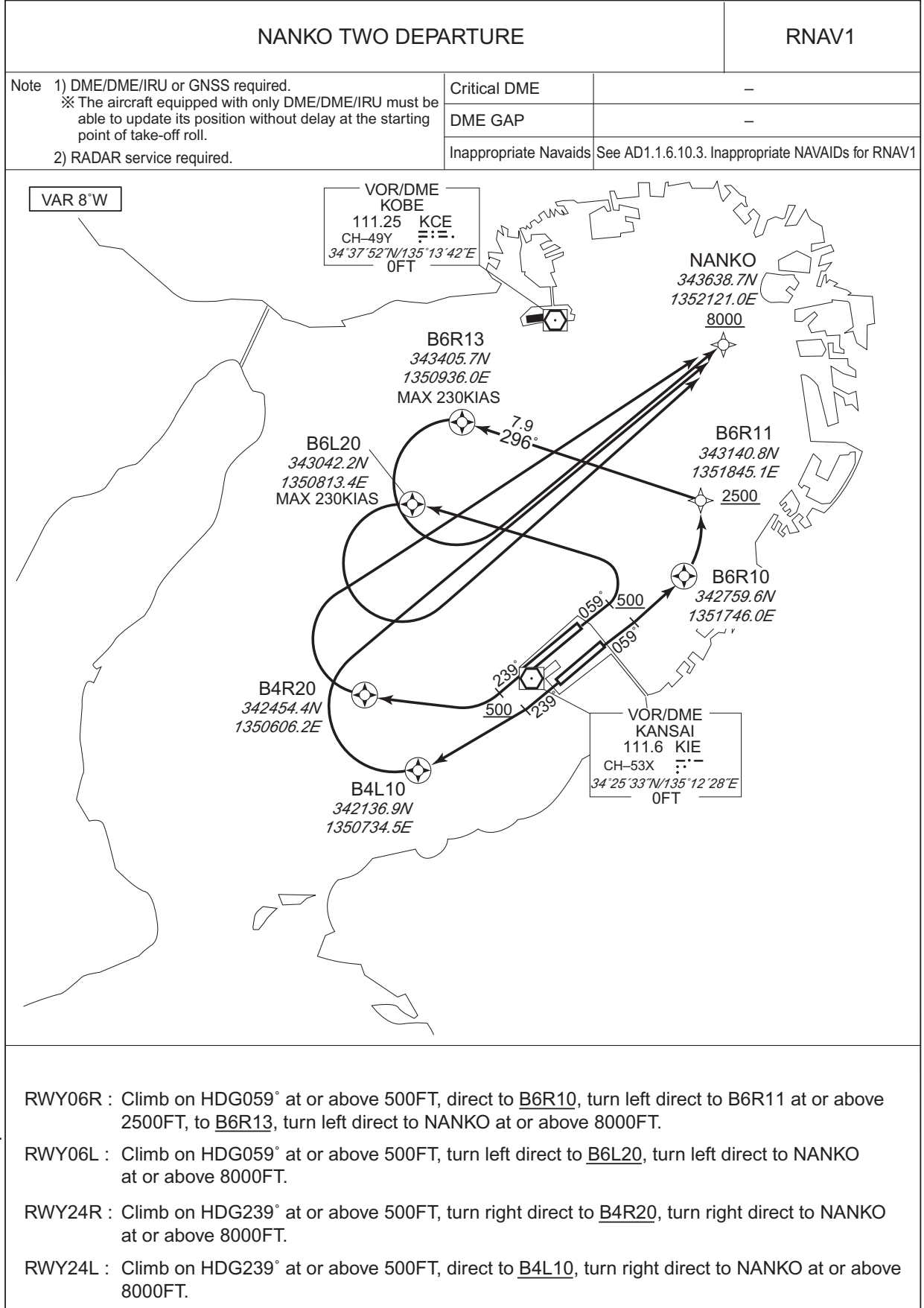

STANDARD DEPARTURE CHART - INSTRUMENT

RJBB / KANSAI INTL

RNAV SID

NANKO TWO DEPARTURE

RWY06R

Serial Number	Path Descriptor	Waypoint Identifier	Fly Over	Course °M(°T)	Magnetic Variation	Distance (NM)	Turn Direction	Altitude (FT)	Speed (KIAS)	Vertical Angle	Navigation Specification
001	VA	—	—	059 (050.9)	-7.9	—	—	+500	—	—	RNAV1
002	DF	B6R10	Y	—	-7.9	—	—	—	—	—	RNAV1
003	DF	B6R11	—	—	-7.9	—	L	+2500	—	—	RNAV1
004	TF	B6R13	Y	296 (287.8)	-7.9	7.9	—	—	-230	—	RNAV1
005	DF	NANKO	—	—	-7.9	—	L	+8000	—	—	RNAV1

RWY06L

Serial Number	Path Descriptor	Waypoint Identifier	Fly Over	Course °M(°T)	Magnetic Variation	Distance (NM)	Turn Direction	Altitude (FT)	Speed (KIAS)	Vertical Angle	Navigation Specification
001	VA	—	—	059 (050.9)	-7.9	—	—	+500	—	—	RNAV1
002	DF	B6L20	Y	—	-7.9	—	L	—	-230	—	RNAV1
003	DF	NANKO	—	—	-7.9	—	L	+8000	—	—	RNAV1

RWY24R

Serial Number	Path Descriptor	Waypoint Identifier	Fly Over	Course °M(°T)	Magnetic Variation	Distance (NM)	Turn Direction	Altitude (FT)	Speed (KIAS)	Vertical Angle	Navigation Specification
001	VA	—	—	239 (230.9)	-7.9	—	—	+500	—	—	RNAV1
002	DF	B4R20	Y	—	-7.9	—	R	—	—	—	RNAV1
003	DF	NANKO	—	—	-7.9	—	R	+8000	—	—	RNAV1

RWY24L

Serial Number	Path Descriptor	Waypoint Identifier	Fly Over	Course °M(°T)	Magnetic Variation	Distance (NM)	Turn Direction	Altitude (FT)	Speed (KIAS)	Vertical Angle	Navigation Specification
001	VA	—	—	239 (230.9)	-7.9	—	—	+500	—	—	RNAV1
002	DF	B4L10	Y	—	-7.9	—	—	—	—	—	RNAV1
003	DF	NANKO	—	—	-7.9	—	R	+8000	—	—	RNAV1

CHANGE : VAR. PROC renamed. PROC course.

STANDARD DEPARTURE CHART - INSTRUMENT

RJBB / KANSAI INTL

RNAV TRANSITION

SIGAK TRANSITION / NAGOYA TRANSITION

RNAV1

Note 1) DME/DME/IRU or GNSS required. 2) RADAR service required.

Inappropriate Nav aids

See AD1.1.6.10.3. Inappropriate NAVAIDs for RNAV1

VAR 8° W

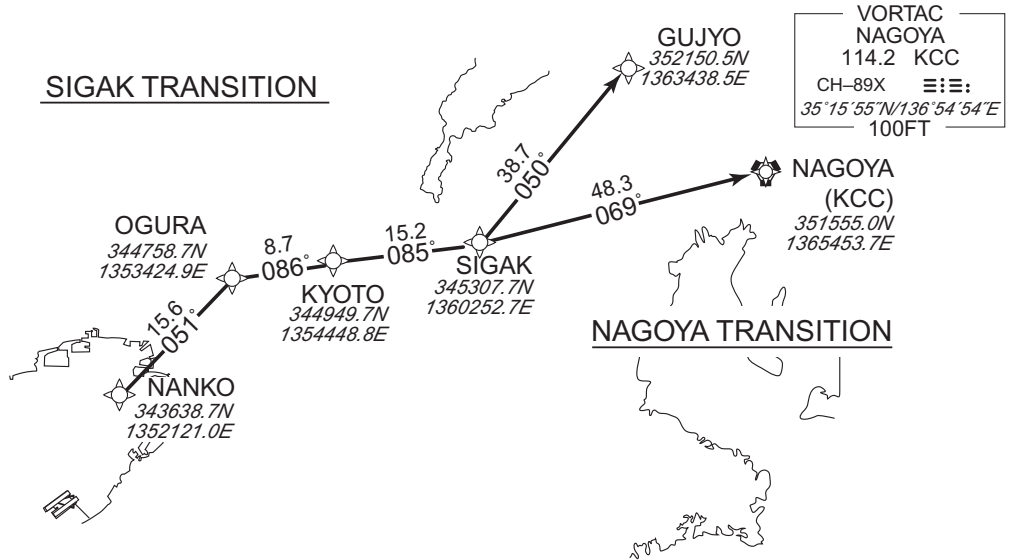

SIGAK TRANSITION

From NANKO, to OGURA, to KYOTO, to SIGAK, to GUJYO.

Critical DME	ITE : 8.0NM to SIGAK - 5.0NM to SIGAK SIGAK - 30.0NM to GUJYO YME : 33.0NM to GUJYO - 30.0NM to GUJYO XMT : 20.0NM to GUJYO - 13.0NM to GUJYO
DME GAP	-

Serial Number	Path Descriptor	Waypoint Identifier	Fly Over	Course °M(°T)	Magnetic Variation	Distance (NM)	Turn Direction	Altitude (FT)	Speed (KIAS)	Vertical Angle	Navigation Specification
001	IF	NANKO	-	-	-7.9	-	-	-	-	-	RNAV1
002	TF	OGURA	-	051 (043.4)	-7.9	15.6	-	-	-	-	RNAV1
003	TF	KYOTO	-	086 (077.7)	-7.9	8.7	-	-	-	-	RNAV1
004	TF	SIGAK	-	085 (077.4)	-7.9	15.2	-	-	-	-	RNAV1
005	TF	GUJYO	-	050 (042.0)	-7.9	38.7	-	-	-	-	RNAV1

NAGOYA TRANSITION

From NANKO, to OGURA, to KYOTO, to SIGAK, to KCC.

Critical DME	ITE : 8.0NM to SIGAK - 5.0NM to SIGAK
DME GAP	-

Serial Number	Path Descriptor	Waypoint Identifier	Fly Over	Course °M(°T)	Magnetic Variation	Distance (NM)	Turn Direction	Altitude (FT)	Speed (KIAS)	Vertical Angle	Navigation Specification
001	IF	NANKO	-	-	-7.9	-	-	-	-	-	RNAV1
002	TF	OGURA	-	051 (043.4)	-7.9	15.6	-	-	-	-	RNAV1
003	TF	KYOTO	-	086 (077.7)	-7.9	8.7	-	-	-	-	RNAV1
004	TF	SIGAK	-	085 (077.4)	-7.9	15.2	-	-	-	-	RNAV1
005	TF	KCC	-	069 (061.6)	-7.9	48.3	-	-	-	-	RNAV1

CHANGE : Description of VAR.

STANDARD DEPARTURE CHART - INSTRUMENT

RJBB / KANSAI INTL

RNAV SID

HELEN TWO DEPARTURE		RNAV1
Note 1) DME/DME/IRU or GNSS required. ※ The aircraft equipped with only DME/DME/IRU must be able to update its position without delay at the starting point of take-off roll. 2) RADAR service required.	Critical DME	-
	DME GAP	-
	Inappropriate NavAids	See AD1.1.6.10.3. Inappropriate NAVAIDS for RNAV1

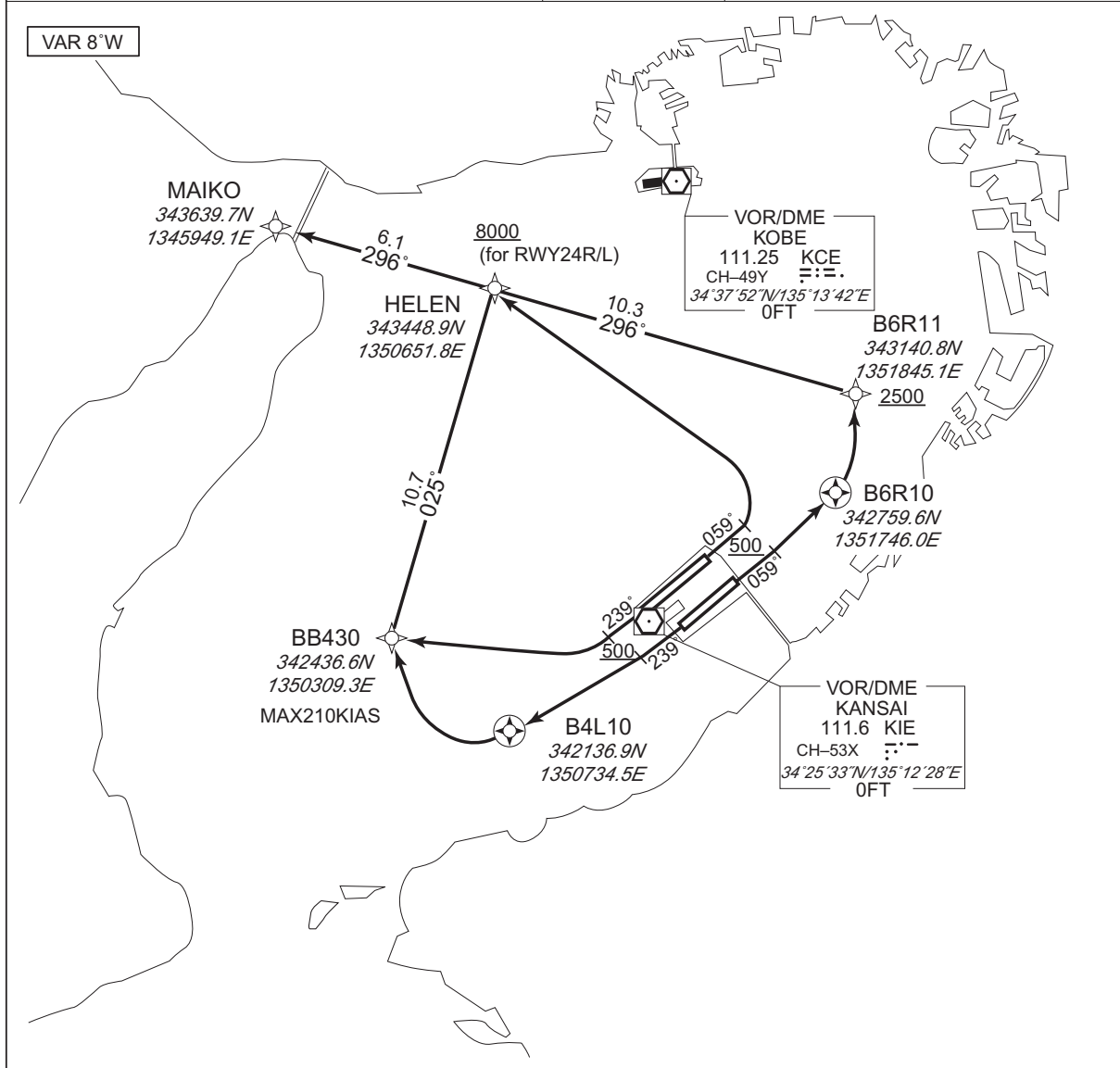

CHANGE : Description of VAR and PROC name.

RWY06R : Climb on HDG059° at or above 500FT, direct to B6R10, turn left direct to B6R11 at or above 2500FT, to HELEN, to MAIKO.

RWY06L : Climb on HDG059° at or above 500FT, turn left direct to HELEN, to MAIKO.

RWY24R : Climb on HDG239° at or above 500FT, turn right direct to BB430, to HELEN at or above 8000FT, to MAIKO.

RWY24L : Climb on HDG239° at or above 500FT, direct to B4L10, turn right direct to BB430, to HELEN at or above 8000FT, to MAIKO.

STANDARD DEPARTURE CHART - INSTRUMENT

RJBB / KANSAI INTL

RNAV SID

HELEN TWO DEPARTURE

RWY06R

Serial Number	Path Descriptor	Waypoint Identifier	Fly Over	Course °M(°T)	Magnetic Variation	Distance (NM)	Turn Direction	Altitude (FT)	Speed (KIAS)	Vertical Angle	Navigation Specification
001	VA	-	-	059 (050.9)	-7.9	-	-	+500	-	-	RNAV1
002	DF	B6R10	Y	-	-7.9	-	-	-	-	-	RNAV1
003	DF	B6R11	-	-	-7.9	-	L	+2500	-	-	RNAV1
004	TF	HELEN	-	296 (287.8)	-7.9	10.3	-	-	-	-	RNAV1
005	TF	MAIKO	-	296 (287.7)	-7.9	6.1	-	-	-	-	RNAV1

RWY06L

Serial Number	Path Descriptor	Waypoint Identifier	Fly Over	Course °M(°T)	Magnetic Variation	Distance (NM)	Turn Direction	Altitude (FT)	Speed (KIAS)	Vertical Angle	Navigation Specification
001	VA	-	-	059 (050.9)	-7.9	-	-	+500	-	-	RNAV1
002	DF	HELEN	-	-	-7.9	-	L	-	-	-	RNAV1
003	TF	MAIKO	-	296 (287.7)	-7.9	6.1	-	-	-	-	RNAV1

RWY24R

Serial Number	Path Descriptor	Waypoint Identifier	Fly Over	Course °M(°T)	Magnetic Variation	Distance (NM)	Turn Direction	Altitude (FT)	Speed (KIAS)	Vertical Angle	Navigation Specification
001	VA	-	-	239 (230.9)	-7.9	-	-	+500	-	-	RNAV1
002	DF	BB430	-	-	-7.9	-	R	-	-210	-	RNAV1
003	TF	HELEN	-	025 (016.6)	-7.9	10.7	-	+8000	-	-	RNAV1
004	TF	MAIKO	-	296 (287.7)	-7.9	6.1	-	-	-	-	RNAV1

RWY24L

Serial Number	Path Descriptor	Waypoint Identifier	Fly Over	Course °M(°T)	Magnetic Variation	Distance (NM)	Turn Direction	Altitude (FT)	Speed (KIAS)	Vertical Angle	Navigation Specification
001	VA	-	-	239 (230.9)	-7.9	-	-	+500	-	-	RNAV1
002	DF	B4L10	Y	-	-7.9	-	-	-	-	-	RNAV1
003	DF	BB430	-	-	-7.9	-	R	-	-210	-	RNAV1
004	TF	HELEN	-	025 (016.6)	-7.9	10.7	-	+8000	-	-	RNAV1
005	TF	MAIKO	-	296 (287.7)	-7.9	6.1	-	-	-	-	RNAV1

CHANGE : VAR. PROC renamed. PROC course.

STANDARD DEPARTURE CHART - INSTRUMENT

RJBB / KANSAI INTL

RNAV SID

IWAYA TWO DEPARTURE	RNAV1
---------------------	-------

Note 1) DME/DME/IRU or GNSS required. ※ The aircraft equipped with only DME/DME/IRU must be able to update its position without delay at the starting point of take-off roll. 2) RADAR service required.	Critical DME	-
	DME GAP	-
	Inappropriate Navaids	See AD1.1.6.10.3. Inappropriate NAVAIDs for RNAV1

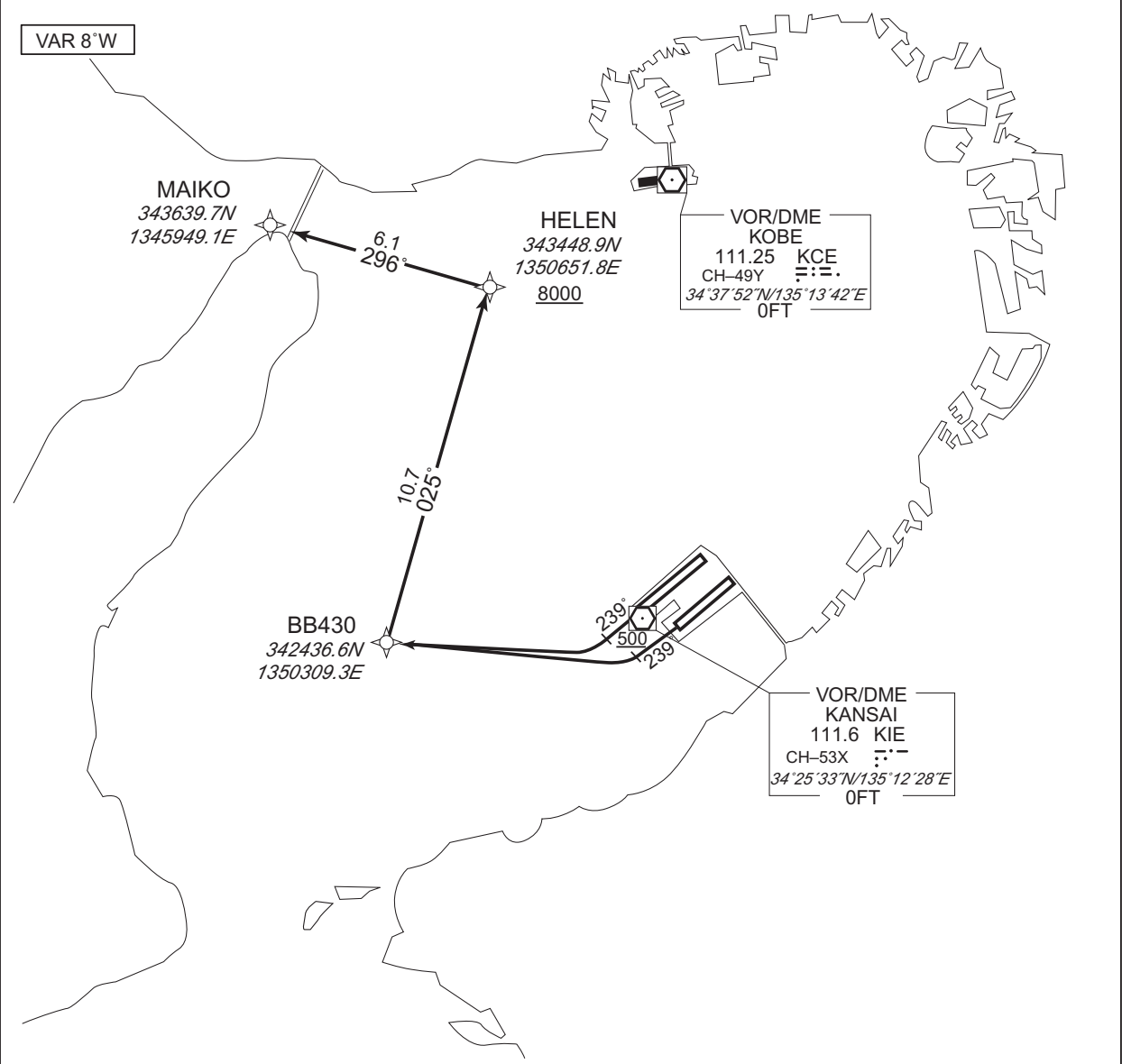

CHANGE : Description of VAR and PROC name.

RWY24R : Climb on HDG239° at or above 500FT, turn right direct to BB430, to HELEN at or above 8000FT, to MAIKO.

RWY24L : Climb on HDG239° at or above 500FT, turn right direct to BB430, to HELEN at or above 8000FT, to MAIKO.

Note RWY24L : No turn before DER.

STANDARD DEPARTURE CHART - INSTRUMENT

RJBB / KANSAI INTL

RNAV SID

IWAYA TWO DEPARTURE

RWY24R

Serial Number	Path Descriptor	Waypoint Identifier	Fly Over	Course °M(°T)	Magnetic Variation	Distance (NM)	Turn Direction	Altitude (FT)	Speed (KIAS)	Vertical Angle	Navigation Specification
001	VA	-	-	239 (230.9)	-7.9	-	-	+500	-	-	RNAV1
002	DF	BB430	-	-	-7.9	-	R	-	-	-	RNAV1
003	TF	HELEN	-	025 (016.6)	-7.9	10.7	-	+8000	-	-	RNAV1
004	TF	MAIKO	-	296 (287.7)	-7.9	6.1	-	-	-	-	RNAV1

RWY24L

Serial Number	Path Descriptor	Waypoint Identifier	Fly Over	Course °M(°T)	Magnetic Variation	Distance (NM)	Turn Direction	Altitude (FT)	Speed (KIAS)	Vertical Angle	Navigation Specification
001	VA	-	-	239 (230.9)	-7.9	-	-	+500	-	-	RNAV1
002	DF	BB430	-	-	-7.9	-	R	-	-	-	RNAV1
003	TF	HELEN	-	025 (016.6)	-7.9	10.7	-	+8000	-	-	RNAV1
004	TF	MAIKO	-	296 (287.7)	-7.9	6.1	-	-	-	-	RNAV1

CHANGE : VAR. PROC renamed. PROC course.

STANDARD DEPARTURE CHART - INSTRUMENT

RJBB / KANSAI INTL

RNAV TRANSITION

SHION TRANSITION / SOUJA TRANSITION / WASYU TRANSITION / HABAR TRANSITION RNAV1

Note 1) DME/DME/IRU or GNSS required. 2) RADAR service required.

Inappropriate NavAids

See AD1.1.6.10.3. Inappropriate NAVAIDs for RNAV1

VAR 8° W

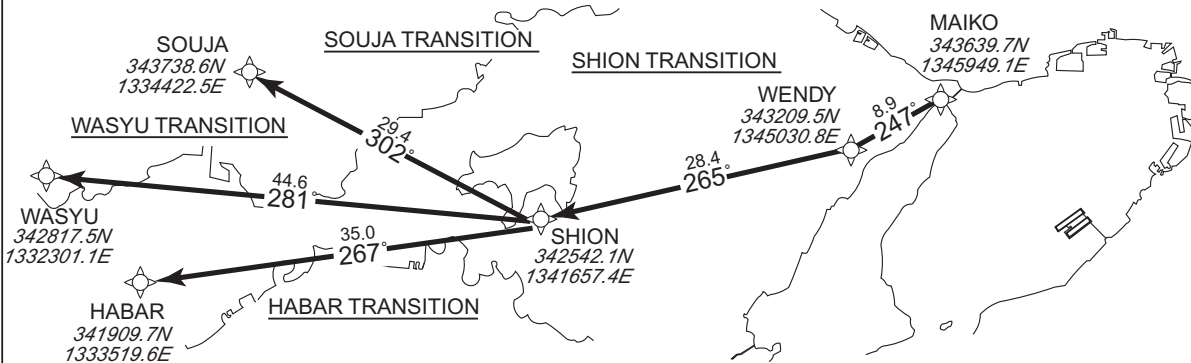

SHION TRANSITION

From MAIKO, to WENDY, to SHION.

Critical DME	—
DME GAP	—

Serial Number	Path Descriptor	Waypoint Identifier	Fly Over	Course °M(°T)	Magnetic Variation	Distance (NM)	Turn Direction	Altitude (FT)	Speed (KIAS)	Vertical Angle	Navigation Specification
001	IF	MAIKO	—	—	-7.9	—	—	—	—	—	RNAV1
002	TF	WENDY	—	247 (239.6)	-7.9	8.9	—	—	—	—	RNAV1
003	TF	SHION	—	265 (257.0)	-7.9	28.4	—	—	—	—	RNAV1

SOUJA TRANSITION

From MAIKO, to WENDY, to SHION, to SOUJA.

Critical DME	—
DME GAP	—

Serial Number	Path Descriptor	Waypoint Identifier	Fly Over	Course °M(°T)	Magnetic Variation	Distance (NM)	Turn Direction	Altitude (FT)	Speed (KIAS)	Vertical Angle	Navigation Specification
001	IF	MAIKO	—	—	-7.9	—	—	—	—	—	RNAV1
002	TF	WENDY	—	247 (239.6)	-7.9	8.9	—	—	—	—	RNAV1
003	TF	SHION	—	265 (257.0)	-7.9	28.4	—	—	—	—	RNAV1
004	TF	SOUJA	—	302 (294.1)	-7.9	29.4	—	—	—	—	RNAV1

WASYU TRANSITION

From MAIKO, to WENDY, to SHION, to WASYU.

Critical DME	—
DME GAP	—

Serial Number	Path Descriptor	Waypoint Identifier	Fly Over	Course °M(°T)	Magnetic Variation	Distance (NM)	Turn Direction	Altitude (FT)	Speed (KIAS)	Vertical Angle	Navigation Specification
001	IF	MAIKO	—	—	-7.9	—	—	—	—	—	RNAV1
002	TF	WENDY	—	247 (239.6)	-7.9	8.9	—	—	—	—	RNAV1
003	TF	SHION	—	265 (257.0)	-7.9	28.4	—	—	—	—	RNAV1
004	TF	WASYU	—	281 (273.6)	-7.9	44.6	—	—	—	—	RNAV1

HABAR TRANSITION

From MAIKO, to WENDY, to SHION, to HABAR.

Critical DME	—
DME GAP	—

Serial Number	Path Descriptor	Waypoint Identifier	Fly Over	Course °M(°T)	Magnetic Variation	Distance (NM)	Turn Direction	Altitude (FT)	Speed (KIAS)	Vertical Angle	Navigation Specification
001	IF	MAIKO	—	—	-7.9	—	—	—	—	—	RNAV1
002	TF	WENDY	—	247 (239.6)	-7.9	8.9	—	—	—	—	RNAV1
003	TF	SHION	—	265 (257.0)	-7.9	28.4	—	—	—	—	RNAV1
004	TF	HABAR	—	267 (259.4)	-7.9	35.0	—	—	—	—	RNAV1

CHANGE : Description of VAR.

STANDARD DEPARTURE CHART - INSTRUMENT

RJBB / KANSAI INTL

RNAV TRANSITION

CHIZU TRANSITION		RNAV1
Note 1) DME/DME/IRU or GNSS required. 2) RADAR service required.	Critical DME	-
	DME GAP	-
	Inappropriate Nav aids	See AD1.1.6.10.3. Inappropriate NAVAIDs for RNAV1.

VAR 8° W

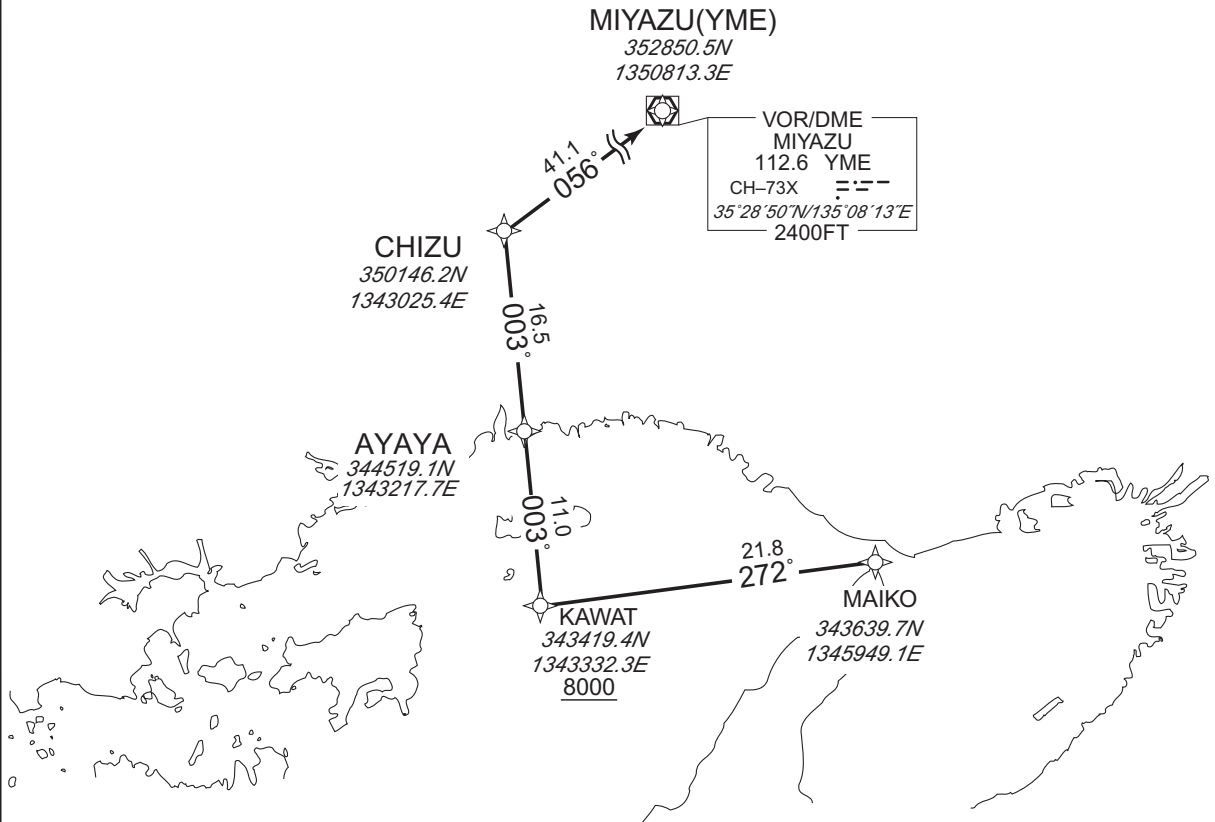

CHANGE : Description of VAR and PROC name.

From MAIKO, to KAWAT at or above 8000FT, to AYAYA, to CHIZU, to YME.

Serial Number	Path Descriptor	Waypoint Identifier	Fly Over	Course °M(T)	Magnetic Variation	Distance (NM)	Turn Direction	Altitude (FT)	Speed (KIAS)	Vertical Angle	Navigation Specification
001	IF	MAIKO	-	-	-7.9	-	-	-	-	-	RNAV1
002	TF	KAWAT	-	272 (264.0)	-7.9	21.8	-	+8000	-	-	RNAV1
003	TF	AYAYA	-	003 (354.7)	-7.9	11.0	-	-	-	-	RNAV1
004	TF	CHIZU	-	003 (354.7)	-7.9	16.5	-	-	-	-	RNAV1
005	TF	YME	-	056 (048.6)	-7.9	41.1	-	-	-	-	RNAV1

STANDARD DEPARTURE CHART - INSTRUMENT

RJBB / KANSAI INTL

RNAV SID

DAISY TWO DEPARTURE		RNAV1
Note 1) DME/DME/IRU or GNSS required. ※ The aircraft equipped with only DME/DME/IRU must be able to update its position without delay at the starting point of take-off roll. 2) RADAR service required.	Critical DME	-
	DME GAP	-
	Inappropriate Nav aids	See AD1.1.6.10.3. Inappropriate NAVAIDs for RNAV1

VAR 8°W

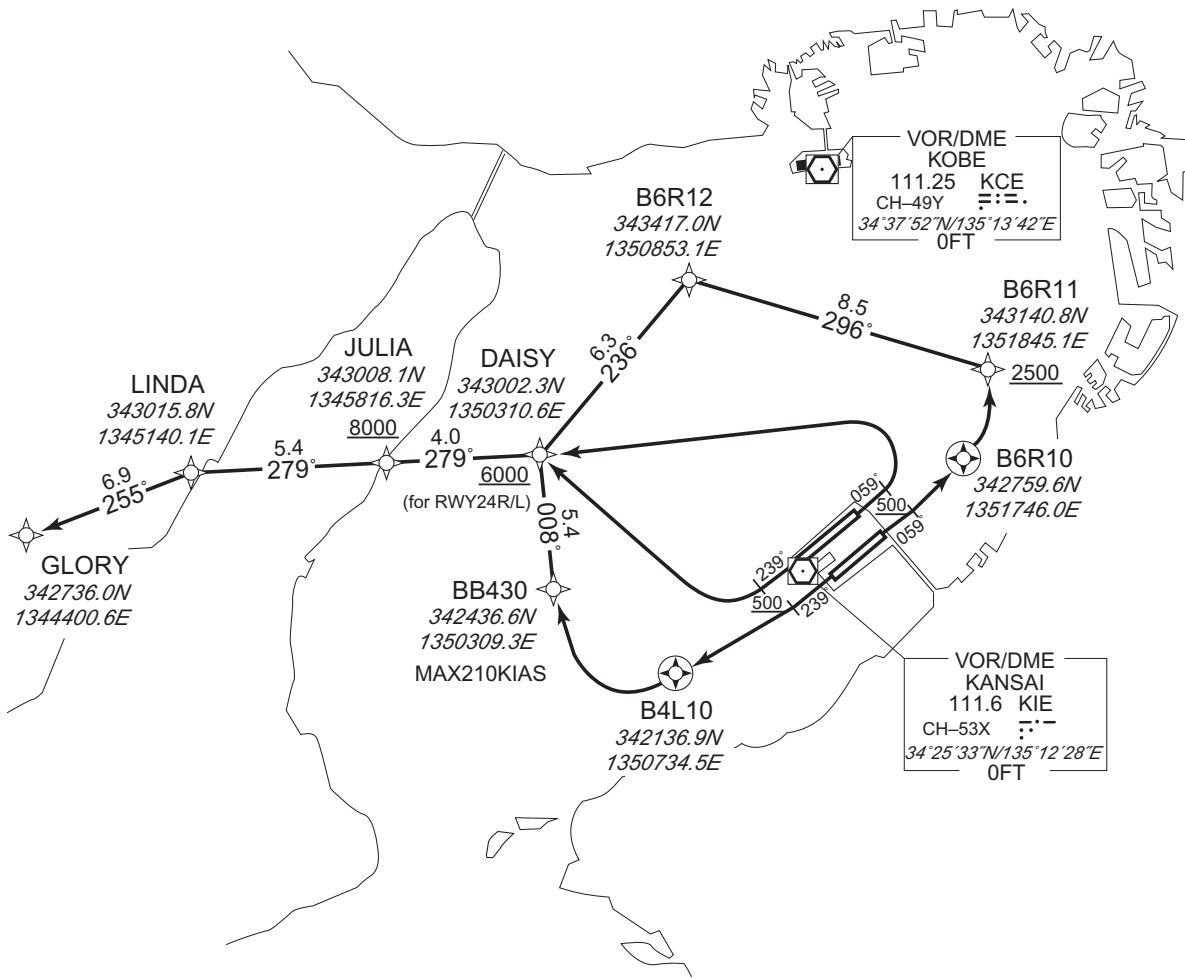

CHANGE : Description of VAR and PROC name.

- RWY06R : Climb on HDG059° at or above 500FT, direct to B6R10, turn left direct to B6R11 at or above 2500FT, to B6R12, to DAISY, to JULIA at or above 8000FT, to LINDA, to GLORY.
- RWY06L : Climb on HDG059° at or above 500FT, turn left direct to DAISY, to JULIA at or above 8000FT, to LINDA, to GLORY.
- RWY24R : Climb on HDG239° at or above 500FT, turn right direct to DAISY at or above 6000FT, to JULIA at or above 8000FT, to LINDA, to GLORY.
- RWY24L : Climb on HDG239° at or above 500FT, direct to B4L10, turn right direct to BB430, to DAISY at or above 6000FT, to JULIA at or above 8000FT, to LINDA, to GLORY.

STANDARD DEPARTURE CHART - INSTRUMENT

RJBB / KANSAI INTL

RNAV SID

DAISY TWO DEPARTURE

RWY06R

Serial Number	Path Descriptor	Waypoint Identifier	Fly Over	Course °M(°T)	Magnetic Variation	Distance (NM)	Turn Direction	Altitude (FT)	Speed (KIAS)	Vertical Angle	Navigation Specification
001	VA	-	-	059 (050.9)	-7.9	-	-	+500	-	-	RNAV1
002	DF	B6R10	Y	-	-7.9	-	-	-	-	-	RNAV1
003	DF	B6R11	-	-	-7.9	-	L	+2500	-	-	RNAV1
004	TF	B6R12	-	296 (287.8)	-7.9	8.5	-	-	-	-	RNAV1
005	TF	DAISY	-	236 (227.9)	-7.9	6.3	-	-	-	-	RNAV1
006	TF	JULIA	-	279 (271.4)	-7.9	4.0	-	+8000	-	-	RNAV1
007	TF	LINDA	-	279 (271.4)	-7.9	5.4	-	-	-	-	RNAV1
008	TF	GLORY	-	255 (247.2)	-7.9	6.9	-	-	-	-	RNAV1

RWY06L

Serial Number	Path Descriptor	Waypoint Identifier	Fly Over	Course °M(°T)	Magnetic Variation	Distance (NM)	Turn Direction	Altitude (FT)	Speed (KIAS)	Vertical Angle	Navigation Specification
001	VA	-	-	059 (050.9)	-7.9	-	-	+500	-	-	RNAV1
002	DF	DAISY	-	-	-7.9	-	L	-	-	-	RNAV1
003	TF	JULIA	-	279 (271.4)	-7.9	4.0	-	+8000	-	-	RNAV1
004	TF	LINDA	-	279 (271.4)	-7.9	5.4	-	-	-	-	RNAV1
005	TF	GLORY	-	255 (247.2)	-7.9	6.9	-	-	-	-	RNAV1

CHANGE : VAR. PROC renamed. PROC course.

STANDARD DEPARTURE CHART - INSTRUMENT

RJBB / KANSAI INTL

RNAV SID

RWY24R

Serial Number	Path Descriptor	Waypoint Identifier	Fly Over	Course °M(°T)	Magnetic Variation	Distance (NM)	Turn Direction	Altitude (FT)	Speed (KIAS)	Vertical Angle	Navigation Specification
001	VA	-	-	239 (230.9)	-7.9	-	-	+500	-	-	RNAV1
002	DF	DAISY	-	-	-7.9	-	R	+6000	-	-	RNAV1
003	TF	JULIA	-	279 (271.4)	-7.9	4.0	-	+8000	-	-	RNAV1
004	TF	LINDA	-	279 (271.4)	-7.9	5.4	-	-	-	-	RNAV1
005	TF	GLORY	-	255 (247.2)	-7.9	6.9	-	-	-	-	RNAV1

RWY24L

Serial Number	Path Descriptor	Waypoint Identifier	Fly Over	Course °M(°T)	Magnetic Variation	Distance (NM)	Turn Direction	Altitude (FT)	Speed (KIAS)	Vertical Angle	Navigation Specification
001	VA	-	-	239 (230.9)	-7.9	-	-	+500	-	-	RNAV1
002	DF	B4L10	Y	-	-7.9	-	-	-	-	-	RNAV1
003	DF	BB430	-	-	-7.9	-	R	-	-210	-	RNAV1
004	TF	DAISY	-	008 (000.2)	-7.9	5.4	-	+6000	-	-	RNAV1
005	TF	JULIA	-	279 (271.4)	-7.9	4.0	-	+8000	-	-	RNAV1
006	TF	LINDA	-	279 (271.4)	-7.9	5.4	-	-	-	-	RNAV1
007	TF	GLORY	-	255 (247.2)	-7.9	6.9	-	-	-	-	RNAV1

CHANGE : VAR. PROC course.

STANDARD DEPARTURE CHART - INSTRUMENT

RJBB / KANSAI INTL

RNAV TRANSITION

HIBIS TRANSITION	RNAV1
------------------	-------

Note 1) DME/DME/IRU or GNSS required. 2) RADAR service required.

Inappropriate NavAids

See AD1.1.6.10.3. Inappropriate NAVAIDs for RNAV1

VAR 8° W

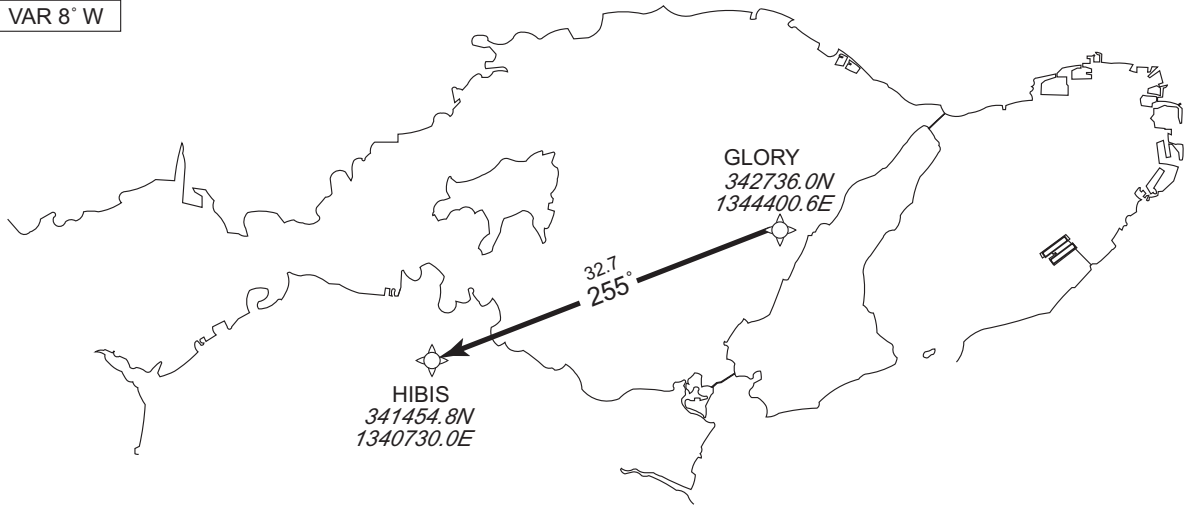

From GLORY, to HIBIS.

Critical DME	-
DME GAP	-

Serial Number	Path Descriptor	Waypoint Identifier	Fly Over	Course °M(°T)	Magnetic Variation	Distance (NM)	Turn Direction	Altitude (FT)	Speed (KIAS)	Vertical Angle	Navigation Specification
001	IF	GLORY	-	-	-7.9	-	-	-	-	-	RNAV1
002	TF	HIBIS	-	255 (247.3)	-7.9	32.7	-	-	-	-	RNAV1

CHANGE : Description of VAR and PROC name.

STANDARD ARRIVAL CHART - INSTRUMENT

RJBB / KANSAI INTL

STAR

AKASI ARRIVAL

From over TSC VORTAC, proceed via TSC R021 to AKASI, via KCE R272 to MAIKO, via YOE R279 to MAYAH.
Cross MAYAH at 4000FT.

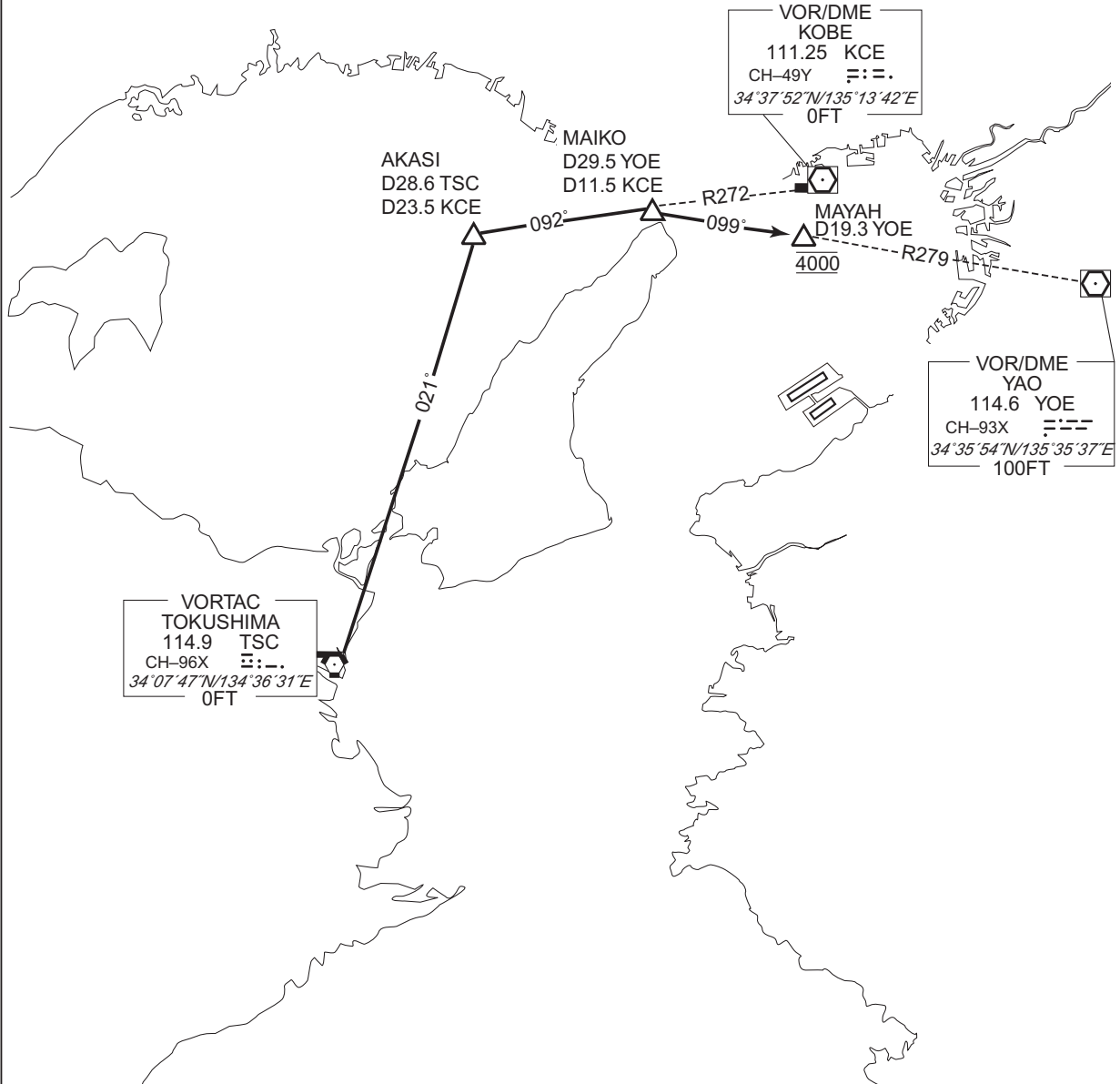

CHANGE : Description of PROC name.

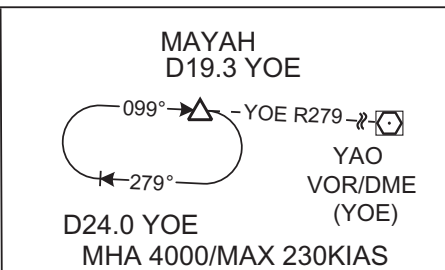
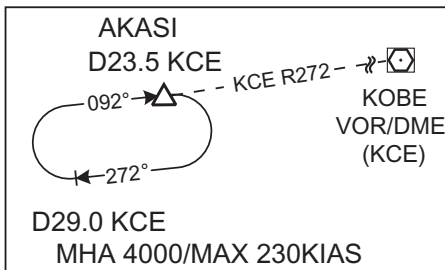

STANDARD ARRIVAL CHART - INSTRUMENT

RJBB / KANSAI INTL

STAR

GATES ARRIVAL

From over TSC VORTAC, proceed via TSC R093 to GATES.
Cross GATES at or above 4000FT.

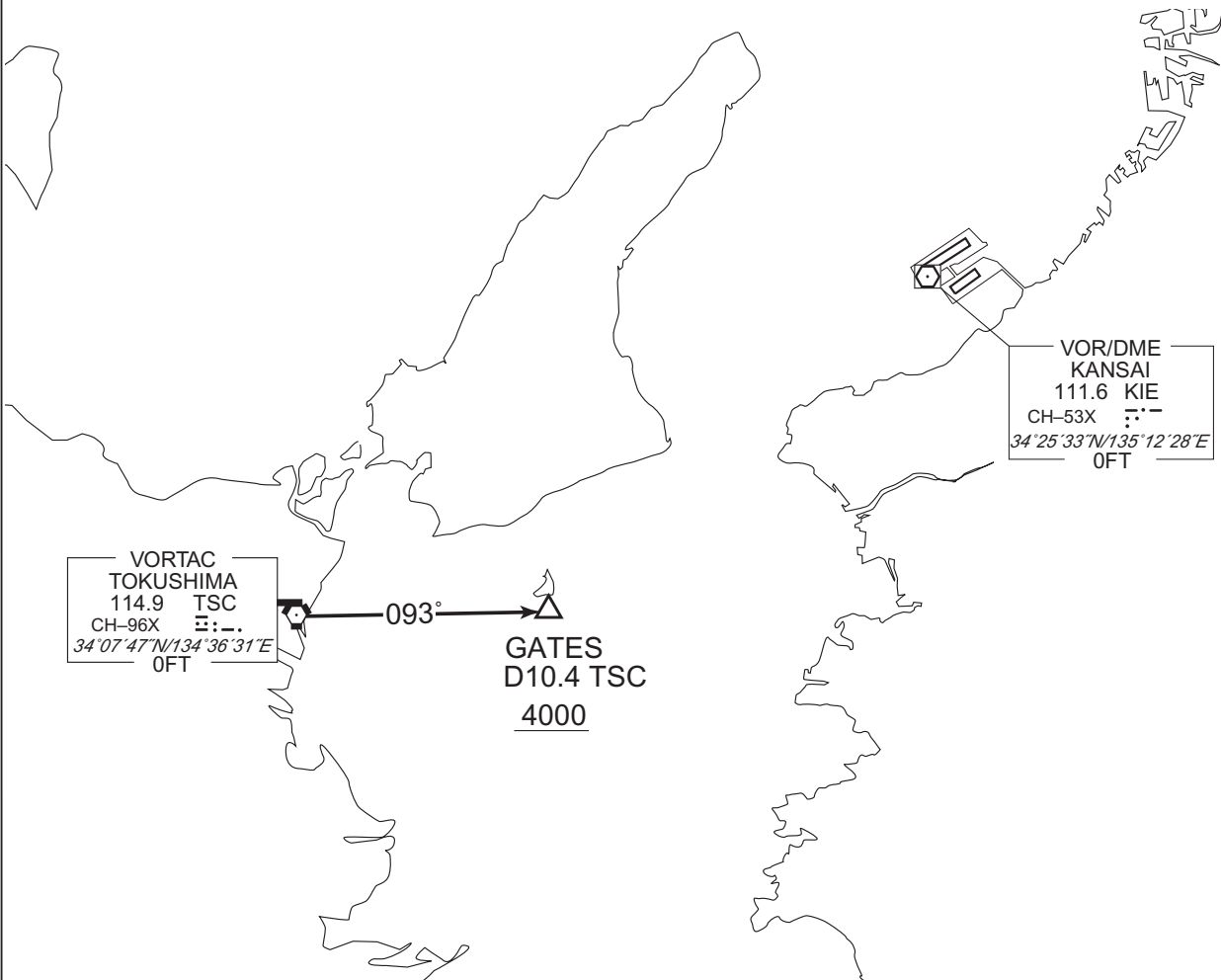

VORTAC
TOKUSHIMA
114.9 TSC
CH-96X
34°07'47"N/134°36'31"E
0FT

VOR/DME
KANSAI
111.6 KIE
CH-53X
34°25'33"N/135°12'28"E
0FT

GATES
D10.4 TSC
4000

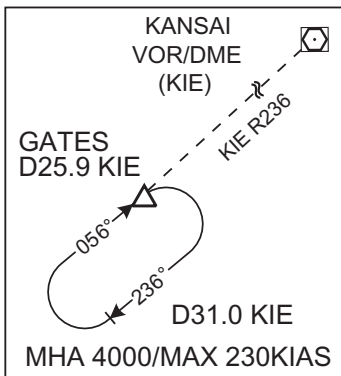

CHANGE : Description of PROC name.

STANDARD ARRIVAL CHART - INSTRUMENT

RJBB / KANSAI INTL RNAV STAR RWY06R/06L

ALVIS ARRIVAL
BURTN ARRIVAL

RNAV1

Note 1) DME/DME/IRU or GNSS required.
2) RADAR service required.

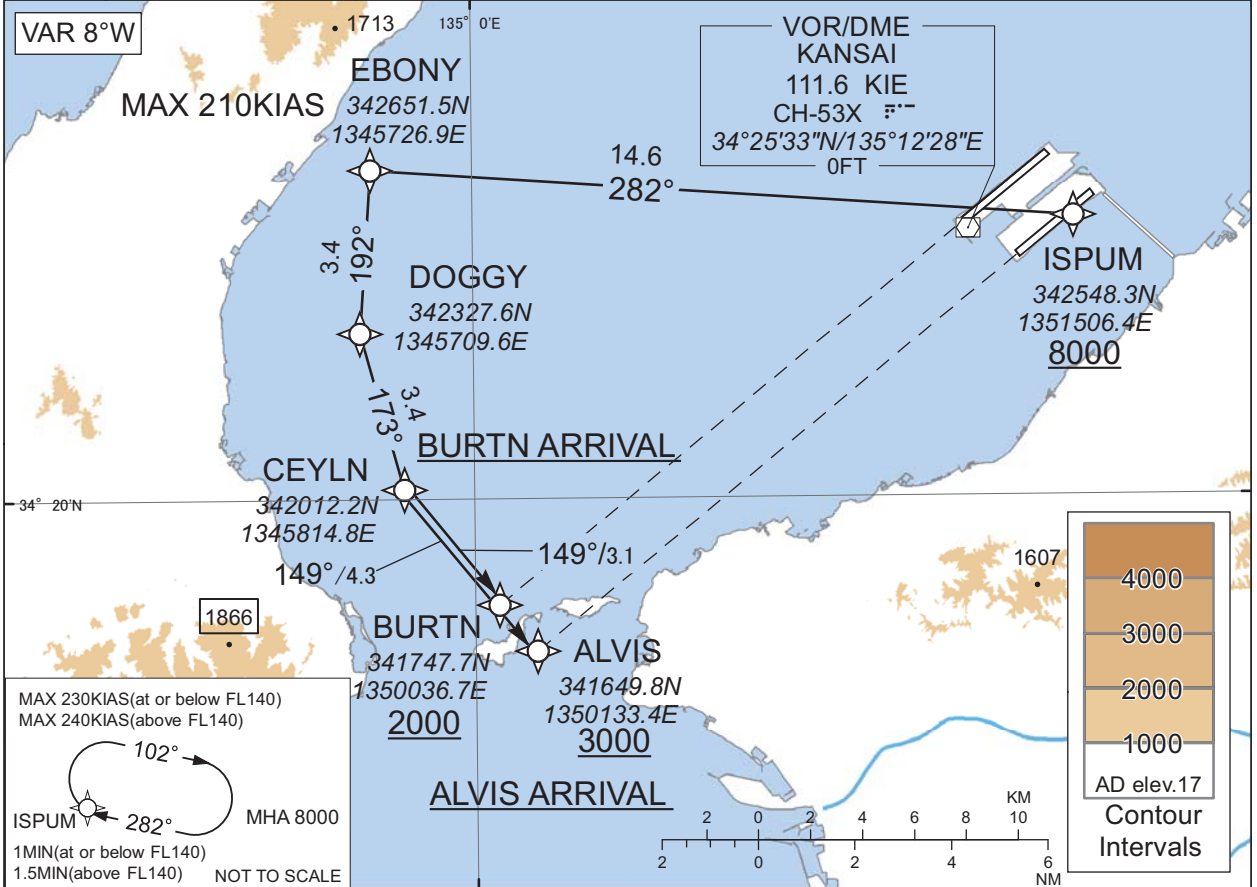

ALVIS ARRIVAL

From ISPUM at or above 8000FT, to EBONY, to DOGGY, to CEYLN, to ALVIS at or above 3000FT.

Critical DME	-
DME GAP	-
Inappropriate Navaids	See AD1.1.6.10.3. Inappropriate NAVAIDs for RNAV1

Serial Number	Path Descriptor	Waypoint Identifier	Fly Over	Course °M(°T)	Magnetic Variation	Distance (NM)	Turn Direction	Altitude (FT)	Speed (KIAS)	Vertical Angle	Navigation Specification
001	IF	ISPUM	-	-	-8.0	-	-	+8000	-	-	RNAV1
002	TF	EBONY	-	282 (274.2)	-8.0	14.6	-	-	-210	-	RNAV1
003	TF	DOGGY	-	192 (184.0)	-8.0	3.4	-	-	-	-	RNAV1
004	TF	CEYLN	-	173 (164.6)	-8.0	3.4	-	-	-	-	RNAV1
005	TF	ALVIS	-	149 (141.0)	-8.0	4.3	-	+3000	-	-	RNAV1

Path	Waypoint Identifier	Inbound Course °M(°T)	Magnetic Variation	Outbound Time (MIN)	Outbound Distance (NM)	Turn Direction	Minimum Altitude (FT)	Maximum Altitude (FT)	Speed (KIAS)	Navigation Specification
HOLD	ISPUM	282 (274.2)	-8.0	1.0(-14000) 1.5(+14001)	-	R	8000	-	-230(-14000) -240(+14001)	RNAV1

CHANGE : Description of VAR.

STANDARD ARRIVAL CHART - INSTRUMENT

RJBB / KANSAI INTL

RNAV STAR RWY06R/06L

BURTN ARRIVAL

From ISPUM at or above 8000FT, to EBONY, to DOGGY, to CEYLN, to BURTN at or above 2000FT.

Critical DME	-
DME GAP	-
Inappropriate Nav aids	See AD1.1.6.10.3. Inappropriate NAVAIDS for RNAV1

Serial Number	Path Descriptor	Waypoint Identifier	Fly Over	Course °M(°T)	Magnetic Variation	Distance (NM)	Turn Direction	Altitude (FT)	Speed (KIAS)	Vertical Angle	Navigation Specification
001	IF	ISPUM	-	-	-8.0	-	-	+8000	-	-	RNAV1
002	TF	EBONY	-	282 (274.2)	-8.0	14.6	-	-	-210	-	RNAV1
003	TF	DOGGY	-	192 (184.0)	-8.0	3.4	-	-	-	-	RNAV1
004	TF	CEYLN	-	173 (164.6)	-8.0	3.4	-	-	-	-	RNAV1
005	TF	BURTN	-	149 (141.0)	-8.0	3.1	-	+2000	-	-	RNAV1

Path	Waypoint Identifier	Inbound Course °M(°T)	Magnetic Variation	Outbound Time (MIN)	Outbound Distance (NM)	Turn Direction	Minimum Altitude (FT)	Maximum Altitude (FT)	Speed (KIAS)	Navigation Specification
HOLD	ISPUM	282 (274.2)	-8.0	1.0(-14000) 1.5(+14001)	-	R	8000	-	-230(-14000) -240(+14001)	RNAV1

CHANGE : VAR. Course FM DOGGY to CEYLN.

STANDARD ARRIVAL CHART - INSTRUMENT

RJBB / KANSAI INTL RNAV STAR RWY24R/24L

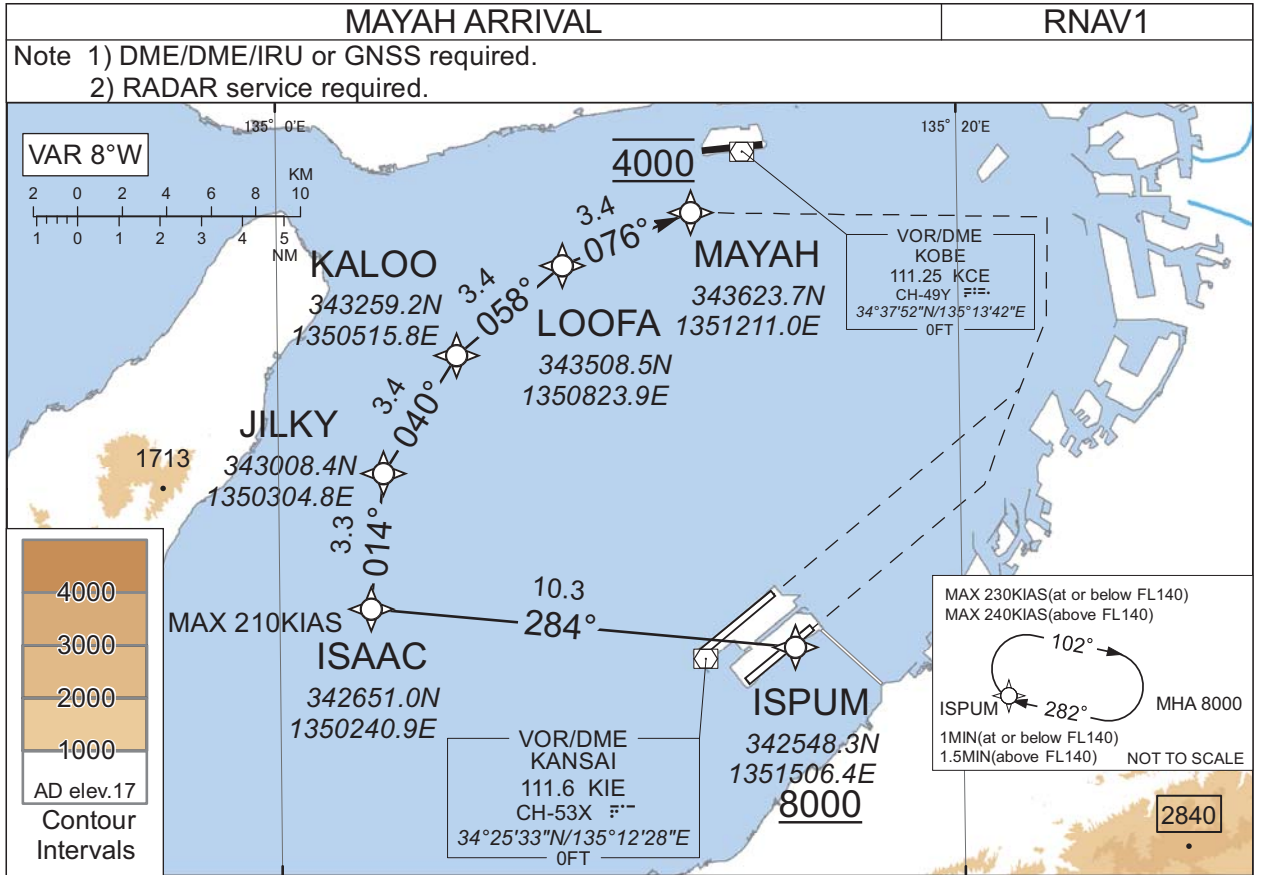

From ISPUM at or above 8000FT, to ISAAC, to JILKY, to KALOO, to LOOFA, to MAYAH at 4000FT.

Critical DME	-
DME GAP	-
Inappropriate Navaids	See AD1.1.6.10.3. Inappropriate NAVAIDs for RNAV1

CHANGE : Description of VAR and PROC name.

Serial Number	Path Descriptor	Waypoint Identifier	Fly Over	Course °M(°T)	Magnetic Variation	Distance (NM)	Turn Direction	Altitude (FT)	Speed (KIAS)	Vertical Angle	Navigation Specification
001	IF	ISPUM	-	-	-8.0	-	-	+8000	-	-	RNAV1
002	TF	ISAAC	-	284 (275.9)	-8.0	10.3	-	-	-210	-	RNAV1
003	TF	JILKY	-	014 (005.7)	-8.0	3.3	-	-	-	-	RNAV1
004	TF	KALOO	-	040 (032.3)	-8.0	3.4	-	-	-	-	RNAV1
005	TF	LOOFA	-	058 (050.1)	-8.0	3.4	-	-	-	-	RNAV1
006	TF	MAYAH	-	076 (068.1)	-8.0	3.4	-	4000	-	-	RNAV1

Path	Waypoint Identifier	Inbound Course °M(°T)	Magnetic Variation	Outbound Time (MIN)	Outbound Distance (NM)	Turn Direction	Minimum Altitude (FT)	Maximum Altitude (FT)	Speed (KIAS)	Navigation Specification
HOLD	ISPUM	282 (274.2)	-8.0	1.0(-14000) 1.5(+14001)	-	R	8000	-	-230(-14000) -240(+14001)	RNAV1

STANDARD ARRIVAL CHART - INSTRUMENT

RJBB / KANSAI INTL

RNAV STAR RWY06L/06R

DANDE ALFA ARRIVAL
DANDE BRAVO ARRIVAL

RNAV1

Note 1) DME/DME/IRU or GNSS required.
2) RADAR service required.

VAR8° W

VOR/DME
KOBE
111.25 KCE
CH-49Y $\equiv::\equiv$
34°37'52"N/135°13'42"E
0FT

VOR/DME
KANSAI
111.6 KIE
CH-53X $\equiv::\equiv$
34°25'33"N/135°12'28"E
0FT

DANDE BRAVO ARRIVAL

BERRY
341502.0N
1345631.6E

ALLAN
4000
341404.1N
1345728.3E

JOLLY 6000
340900.6N
1350225.6E

DANDE ALFA ARRIVAL

DANDE
341309.4N
1352433.9E

7.8 for BERRY
6.5 for ALLAN
329°

18.8

265°

DME
GOBOH
1203 GBD
CH-116X $\equiv::\equiv$
33°54'37"N/135°06'22"E
1000FT

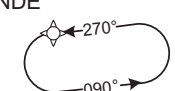
NOT TO SCALE
MAX 230KIAS(at or below FL140)
MAX 240KIAS(above FL140)
DANDE

MHA 8000
1MIN(at or below FL140)
1.5MIN(above FL140)

CHANGE : Description of VAR.

STANDARD ARRIVAL CHART - INSTRUMENT

RJBB / KANSAI INTL

RNAV STAR RWY06L/06R

DANDE ALFA ARRIVAL

From DANDE, to JOLLY at or above 6000FT, to ALLAN at or above 4000FT.

Critical DME	—
DME GAP	—
Inappropriate Nav aids	See AD1.1.6.10.3. Inappropriate NAVAIDs for RNAV1

Serial Number	Path Descriptor	Waypoint Identifier	Fly Over	Course [°M(°T)]	Magnetic Variation	Distance (NM)	Turn Direction	Altitude (FT)	Speed (KIAS)	Vertical Angle	Navigation Specification
001	IF	DANDE	—	—	-8.0	—	—	—	—	—	RNAV1
002	TF	JOLLY	—	265 (257.3)	-8.0	18.8	—	+6000	—	—	RNAV1
003	TF	ALLAN	—	329 (321.0)	-8.0	6.5	—	+4000	—	—	RNAV1

Path	Waypoint Identifier	Inbound Course °M(°T)	Magnetic Variation	Outbound Time (MIN)	Outbound Distance (NM)	Turn Direction	Minimum Altitude (FT)	Maximum Altitude (FT)	Speed (KIAS)	Navigation Specification
Hold	DANDE	270 (262.6)	-8.0	1.0(-14000) 1.5(+14001)	—	L	8000	—	-230(-14000) -240(+14001)	RNAV1

DANDE BRAVO ARRIVAL

From DANDE, to JOLLY at or above 6000FT, to BERRY at or above 4000FT.

Critical DME	—
DME GAP	—
Inappropriate Nav aids	See AD1.1.6.10.3. Inappropriate NAVAIDs for RNAV1

Serial Number	Path Descriptor	Waypoint Identifier	Fly Over	Course [°M(°T)]	Magnetic Variation	Distance (NM)	Turn Direction	Altitude (FT)	Speed (KIAS)	Vertical Angle	Navigation Specification
001	IF	DANDE	—	—	-8.0	—	—	—	—	—	RNAV1
002	TF	JOLLY	—	265 (257.3)	-8.0	18.8	—	+6000	—	—	RNAV1
003	TF	BERRY	—	329 (321.0)	-8.0	7.8	—	+4000	—	—	RNAV1

Path	Waypoint Identifier	Inbound Course °M(°T)	Magnetic Variation	Outbound Time (MIN)	Outbound Distance (NM)	Turn Direction	Minimum Altitude (FT)	Maximum Altitude (FT)	Speed (KIAS)	Navigation Specification
Hold	DANDE	270 (262.6)	-8.0	1.0(-14000) 1.5(+14001)	—	L	8000	—	-230(-14000) -240(+14001)	RNAV1

CHANGE : VAR. Critical DME deleted.

STANDARD ARRIVAL CHART - INSTRUMENT

RJBB / KANSAI INTL

RNAV STAR RWY24L/24R

DANDE CHARLIE ARRIVAL

RNAV1

Note 1) DME/DME/IRU or GNSS required.
2) RADAR service required.

VAR 8° W

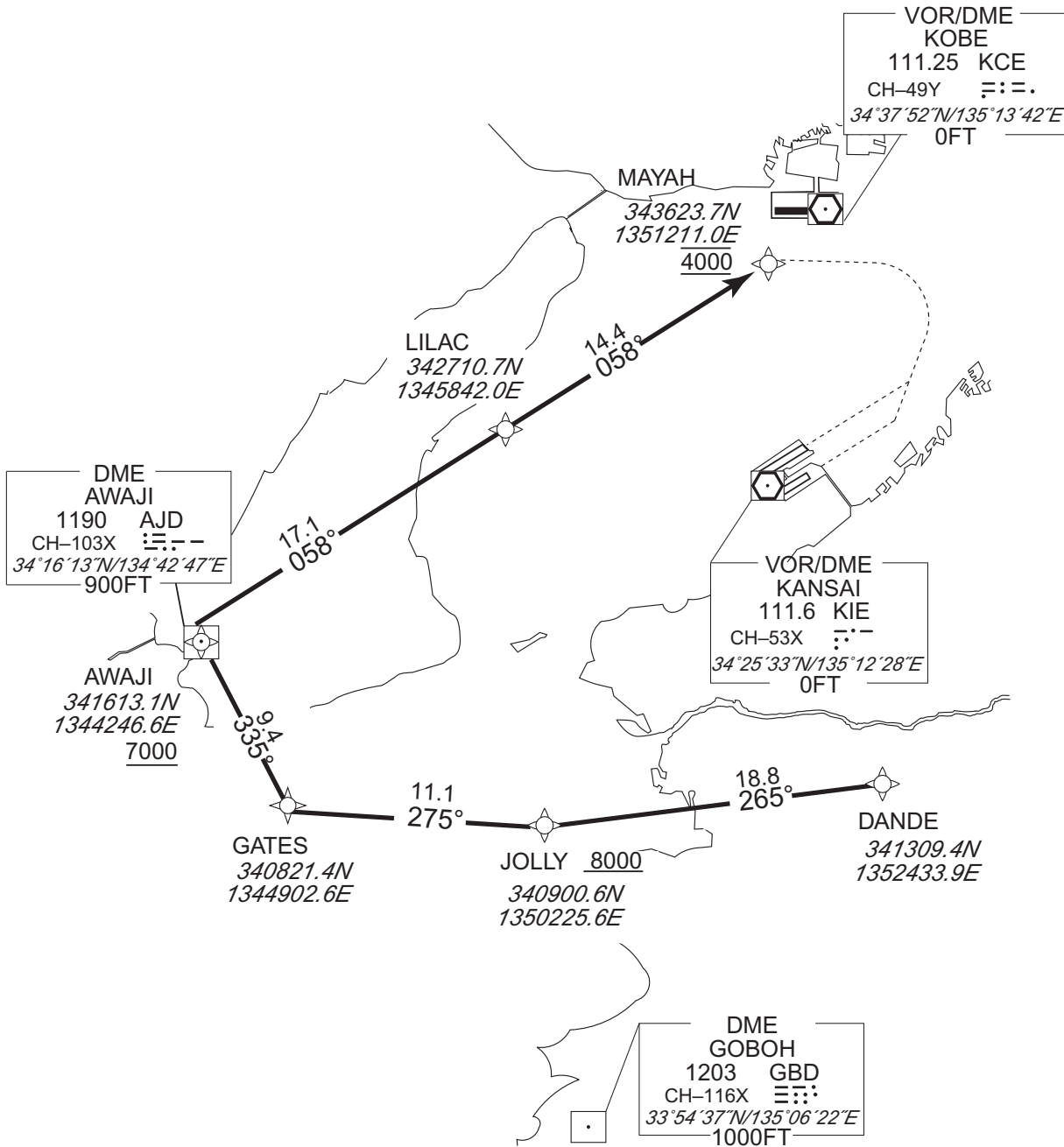

CHANGE : Description of VAR and PROC name.

MAX 230KIAS(at or below FL140)
MAX 240KIAS(above FL140)
LILAC NOT TO SCALE
MHA 3000
1MIN(at or below FL140)
1.5MIN(above FL140)

MAX 230KIAS(at or below FL140)
MAX 240KIAS(above FL140)
DANDE NOT TO SCALE
MHA 8000
1MIN(at or below FL140)
1.5MIN(above FL140)

STANDARD ARRIVAL CHART - INSTRUMENT

RJBB / KANSAI INTL

RNAV STAR RWY24L/24R

DANDE CHARLIE ARRIVAL

From DANDE, to JOLLY at or above 8000FT, to GATES, to AWAJI at or above 7000FT, to LILAC, to MAYAH at 4000FT.

Critical DME	-
DME GAP	-
Inappropriate Nav aids	See AD1.1.6.10.3. Inappropriate NAVAIDs for RNAV1

Serial Number	Path Descriptor	Waypoint Identifier	Fly Over	Course [°M(°T)]	Magnetic Variation	Distance (NM)	Turn Direction	Altitude (FT)	Speed (KIAS)	Vertical Angle	Navigation Specification
001	IF	DANDE	-	-	-8.0	-	-	-	-	-	RNAV1
002	TF	JOLLY	-	265 (257.3)	-8.0	18.8	-	+8000	-	-	RNAV1
003	TF	GATES	-	275 (266.7)	-8.0	11.1	-	-	-	-	RNAV1
004	TF	AWAJI	-	335 (326.6)	-8.0	9.4	-	+7000	-	-	RNAV1
005	TF	LILAC	-	058 (050.1)	-8.0	17.1	-	-	-	-	RNAV1
006	TF	MAYAH	-	058 (050.3)	-8.0	14.4	-	4000	-	-	RNAV1

Path	Waypoint Identifier	Inbound Course °M(°T)	Magnetic Variation	Outbound Time (MIN)	Outbound Distance (NM)	Turn Direction	Minimum Altitude (FT)	Maximum Altitude (FT)	Speed (KIAS)	Navigation Specification
Hold	DANDE	270 (262.6)	-8.0	1.0(-14000) 1.5(+14001)	-	L	8000	-	-230(-14000) -240(+14001)	RNAV1
Hold	LILAC	057 (049.2)	-8.0	1.0(-14000) 1.5(+14001)	-	R	3000	-	-230(-14000) -240(+14001)	RNAV1

CHANGE : Critical DME, DME GAP deleted.

STANDARD ARRIVAL CHART - INSTRUMENT

RJBB / KANSAI INTL

RNAV STAR RWY06L/06R

ALISA ALFA / BRAVO ARRIVAL
BECKY ALFA / BRAVO ARRIVAL
CANDY ALFA / BRAVO ARRIVAL

RNAV1

Note 1) DME/DME/IRU or GNSS required.
2) RADAR service required.

VAR 8° W

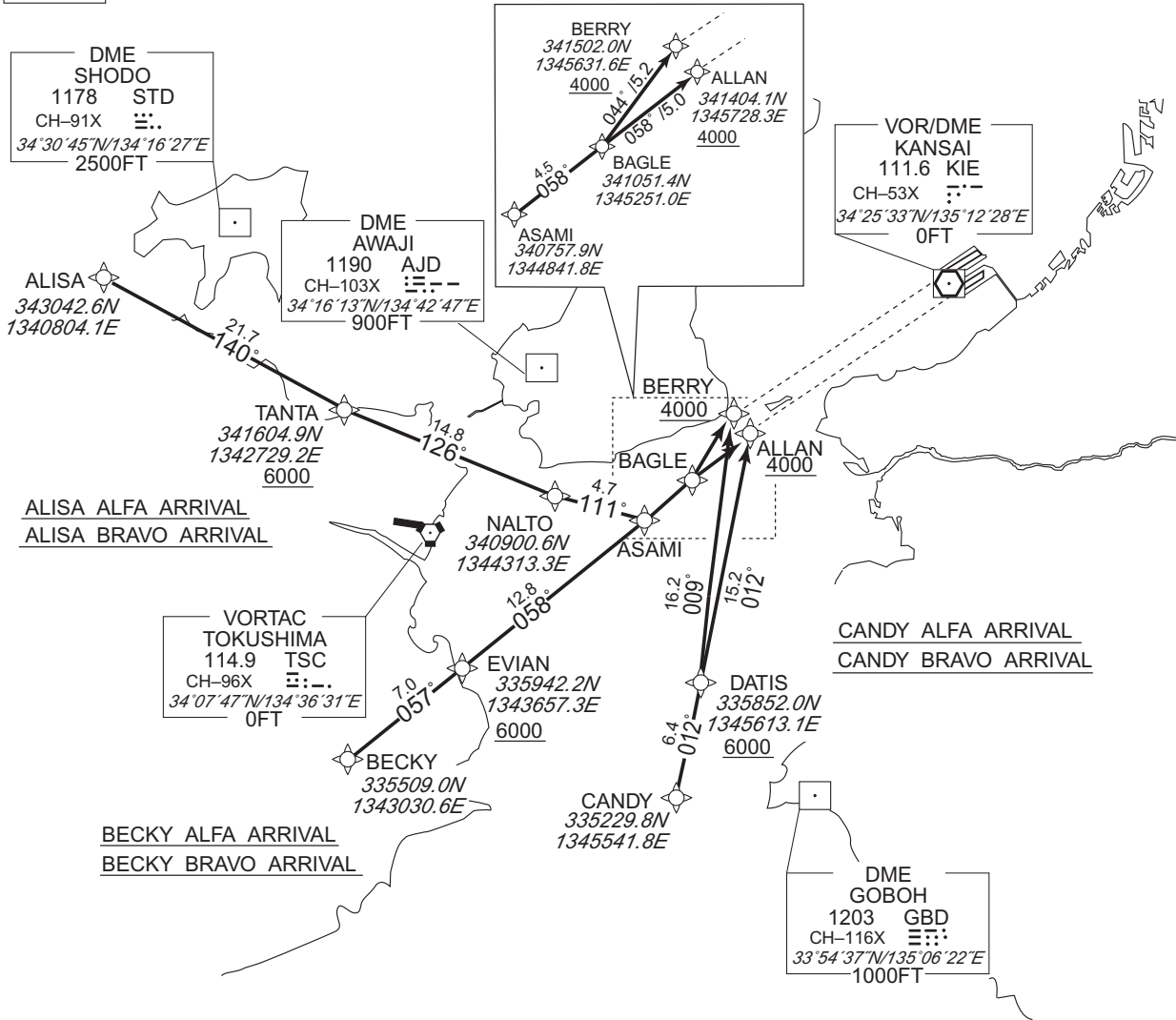

CHANGE : Description of VAR.

NOT TO SCALE	NOT TO SCALE	NOT TO SCALE	NOT TO SCALE	NOT TO SCALE
MAX 230KIAS(at or below FL140) MAX 240KIAS(above FL140)	MAX 230KIAS(at or below FL140) MAX 240KIAS(above FL140)	MAX 230KIAS(at or below FL140) MAX 240KIAS(above FL140)	MAX 230KIAS(at or below FL140) MAX 240KIAS(above FL140)	MAX 230KIAS(at or below FL140) MAX 240KIAS(above FL140)
1MIN(at or below FL140) 1.5MIN(above FL140)	1MIN(at or below FL140) 1.5MIN(above FL140)	1MIN(at or below FL140) 1.5MIN(above FL140)	1MIN(at or below FL140) 1.5MIN(above FL140)	1MIN(at or below FL140) 1.5MIN(above FL140)

STANDARD ARRIVAL CHART - INSTRUMENT

RJBB / KANSAI INTL

RNAV STAR RWY06L/06R

ALISA ALFA ARRIVAL

From ALISA, to TANTA at or above 6000FT, to NALTO, to ASAMI, to BAGLE, to ALLAN at or above 4000FT.

Critical DME	—
DME GAP	—
Inappropriate Nav aids	See AD1.1.6.10.3. Inappropriate NAVAIDs for RNAV1

Serial Number	Path Descriptor	Waypoint Identifier	Fly Over	Course [°M(°T)]	Magnetic Variation	Distance (NM)	Turn Direction	Altitude (FT)	Speed (KIAS)	Vertical Angle	Navigation Specification
001	IF	ALISA	—	—	-8.0	—	—	—	—	—	RNAV1
002	TF	TANTA	—	140 (132.3)	-8.0	21.7	—	+6000	—	—	RNAV1
003	TF	NALTO	—	126 (118.4)	-8.0	14.8	—	—	—	—	RNAV1
004	TF	ASAMI	—	111 (103.0)	-8.0	4.7	—	—	—	—	RNAV1
005	TF	BAGLE	—	058 (049.9)	-8.0	4.5	—	—	—	—	RNAV1
006	TF	ALLAN	—	058 (049.9)	-8.0	5.0	—	+4000	—	—	RNAV1

Path	Waypoint Identifier	Inbound Course °M(°T)	Magnetic Variation	Outbound Time (MIN)	Outbound Distance (NM)	Turn Direction	Minimum Altitude (FT)	Maximum Altitude (FT)	Speed (KIAS)	Navigation Specification
Hold	ALISA	142 (134.0)	-8.0	1.0(-14000) 1.5(+14001)	—	R	10000	—	-230(-14000) -240(+14001)	RNAV1
Hold	ASAMI	059 (050.7)	-8.0	1.0(-14000) 1.5(+14001)	—	R	4000	—	-230(-14000) -240(+14001)	RNAV1

ALISA BRAVO ARRIVAL

From ALISA, to TANTA at or above 6000FT, NALTO, to ASAMI, to BAGLE, to BERRY at or above 4000FT.

Critical DME	—
DME GAP	—
Inappropriate Nav aids	See AD1.1.6.10.3. Inappropriate NAVAIDs for RNAV1

Serial Number	Path Descriptor	Waypoint Identifier	Fly Over	Course [°M(°T)]	Magnetic Variation	Distance (NM)	Turn Direction	Altitude (FT)	Speed (KIAS)	Vertical Angle	Navigation Specification
001	IF	ALISA	—	—	-8.0	—	—	—	—	—	RNAV1
002	TF	TANTA	—	140 (132.3)	-8.0	21.7	—	+6000	—	—	RNAV1
003	TF	NALTO	—	126 (118.4)	-8.0	14.8	—	—	—	—	RNAV1
004	TF	ASAMI	—	111 (103.0)	-8.0	4.7	—	—	—	—	RNAV1
005	TF	BAGLE	—	058 (049.9)	-8.0	4.5	—	—	—	—	RNAV1
006	TF	BERRY	—	044 (036.0)	-8.0	5.2	—	+4000	—	—	RNAV1

Path	Waypoint Identifier	Inbound Course °M(°T)	Magnetic Variation	Outbound Time (MIN)	Outbound Distance (NM)	Turn Direction	Minimum Altitude (FT)	Maximum Altitude (FT)	Speed (KIAS)	Navigation Specification
Hold	ALISA	142 (134.0)	-8.0	1.0(-14000) 1.5(+14001)	—	R	10000	—	-230(-14000) -240(+14001)	RNAV1
Hold	ASAMI	059 (050.7)	-8.0	1.0(-14000) 1.5(+14001)	—	R	4000	—	-230(-14000) -240(+14001)	RNAV1

CHANGE : Critical DME.

STANDARD ARRIVAL CHART - INSTRUMENT

RJBB / KANSAI INTL

RNAV STAR RWY06L/06R

BECKY ALFA ARRIVAL

From BECKY, to EVIAN at or above 6000FT, to ASAMI, to BAGLE, to ALLAN at or above 4000FT.

Critical DME	—
DME GAP	—
Inappropriate Nav aids	See AD1.1.6.10.3. Inappropriate NAVAIDs for RNAV1

Serial Number	Path Descriptor	Waypoint Identifier	Fly Over	Course [°M(°T)]	Magnetic Variation	Distance (NM)	Turn Direction	Altitude (FT)	Speed (KIAS)	Vertical Angle	Navigation Specification
001	IF	BECKY	—	—	-8.0	—	—	—	—	—	RNAV1
002	TF	EVIAN	—	057 (049.5)	-8.0	7.0	—	+6000	—	—	RNAV1
003	TF	ASAMI	—	058 (049.6)	-8.0	12.8	—	—	—	—	RNAV1
004	TF	BAGLE	—	058 (049.9)	-8.0	4.5	—	—	—	—	RNAV1
005	TF	ALLAN	—	058 (049.9)	-8.0	5.0	—	+4000	—	—	RNAV1

Path	Waypoint Identifier	Inbound Course °M(°T)	Magnetic Variation	Outbound Time (MIN)	Outbound Distance (NM)	Turn Direction	Minimum Altitude (FT)	Maximum Altitude (FT)	Speed (KIAS)	Navigation Specification
Hold	BECKY	058 (050.2)	-8.0	1.0(-14000) 1.5(+14001)	—	R	8000	—	-230(-14000) -240(+14001)	RNAV1
Hold	ASAMI	059 (050.7)	-8.0	1.0(-14000) 1.5(+14001)	—	R	4000	—	-230(-14000) -240(+14001)	RNAV1

BECKY BRAVO ARRIVAL

From BECKY, to EVIAN at or above 6000FT, to ASAMI, to BAGLE, to BERRY at or above 4000FT.

Critical DME	—
DME GAP	—
Inappropriate Nav aids	See AD1.1.6.10.3. Inappropriate NAVAIDs for RNAV1

Serial Number	Path Descriptor	Waypoint Identifier	Fly Over	Course [°M(°T)]	Magnetic Variation	Distance (NM)	Turn Direction	Altitude (FT)	Speed (KIAS)	Vertical Angle	Navigation Specification
001	IF	BECKY	—	—	-8.0	—	—	—	—	—	RNAV1
002	TF	EVIAN	—	057 (049.5)	-8.0	7.0	—	+6000	—	—	RNAV1
003	TF	ASAMI	—	058 (049.6)	-8.0	12.8	—	—	—	—	RNAV1
004	TF	BAGLE	—	058 (049.9)	-8.0	4.5	—	—	—	—	RNAV1
005	TF	BERRY	—	044 (036.0)	-8.0	5.2	—	+4000	—	—	RNAV1

Path	Waypoint Identifier	Inbound Course °M(°T)	Magnetic Variation	Outbound Time (MIN)	Outbound Distance (NM)	Turn Direction	Minimum Altitude (FT)	Maximum Altitude (FT)	Speed (KIAS)	Navigation Specification
Hold	BECKY	058 (050.2)	-8.0	1.0(-14000) 1.5(+14001)	—	R	8000	—	-230(-14000) -240(+14001)	RNAV1
Hold	ASAMI	059 (050.7)	-8.0	1.0(-14000) 1.5(+14001)	—	R	4000	—	-230(-14000) -240(+14001)	RNAV1

CHANGE : VAR. Course FM EVIAN to ASAMI.

STANDARD ARRIVAL CHART - INSTRUMENT

RJBB / KANSAI INTL

RNAV STAR RWY06L/06R

CANDY ALFA ARRIVAL

From CANDY, to DATIS at or above 6000FT, to ALLAN at or above 4000FT.

Critical DME	—
DME GAP	—
Inappropriate Nav aids	See AD1.1.6.10.3. Inappropriate NAVAIDs for RNAV1

Serial Number	Path Descriptor	Waypoint Identifier	Fly Over	Course [°M(°T)]	Magnetic Variation	Distance (NM)	Turn Direction	Altitude (FT)	Speed (KIAS)	Vertical Angle	Navigation Specification
001	IF	CANDY	—	—	-8.0	—	—	—	—	—	RNAV1
002	TF	DATIS	—	012 (003.9)	-8.0	6.4	—	+6000	—	—	RNAV1
003	TF	ALLAN	—	012 (003.9)	-8.0	15.2	—	+4000	—	—	RNAV1

Path	Waypoint Identifier	Inbound Course °M(°T)	Magnetic Variation	Outbound Time (MIN)	Outbound Distance (NM)	Turn Direction	Minimum Altitude (FT)	Maximum Altitude (FT)	Speed (KIAS)	Navigation Specification
Hold	CANDY	322 (313.8)	-8.0	1.0(-14000) 1.5(+14001)	—	L	9000	—	-230(-14000) -240(+14001)	RNAV1
Hold	DATIS	307 (298.6)	-8.0	1.0(-14000) 1.5(+14001)	—	L	6000	—	-230(-14000) -240(+14001)	RNAV1

CANDY BRAVO ARRIVAL

From CANDY, to DATIS at or above 6000FT, to BERRY at or above 4000FT.

Critical DME	—
DME GAP	—
Inappropriate Nav aids	See AD1.1.6.10.3. Inappropriate NAVAIDs for RNAV1

Serial Number	Path Descriptor	Waypoint Identifier	Fly Over	Course [°M(°T)]	Magnetic Variation	Distance (NM)	Turn Direction	Altitude (FT)	Speed (KIAS)	Vertical Angle	Navigation Specification
001	IF	CANDY	—	—	-8.0	—	—	—	—	—	RNAV1
002	TF	DATIS	—	012 (003.9)	-8.0	6.4	—	+6000	—	—	RNAV1
003	TF	BERRY	—	009 (000.9)	-8.0	16.2	—	+4000	—	—	RNAV1

Path	Waypoint Identifier	Inbound Course °M(°T)	Magnetic Variation	Outbound Time (MIN)	Outbound Distance (NM)	Turn Direction	Minimum Altitude (FT)	Maximum Altitude (FT)	Speed (KIAS)	Navigation Specification
Hold	CANDY	322 (313.8)	-8.0	1.0(-14000) 1.5(+14001)	—	L	9000	—	-230(-14000) -240(+14001)	RNAV1
Hold	DATIS	307 (298.6)	-8.0	1.0(-14000) 1.5(+14001)	—	L	6000	—	-230(-14000) -240(+14001)	RNAV1

CHANGE : VAR.

STANDARD ARRIVAL CHART - INSTRUMENT

RJBB / KANSAI INTL

RNAV STAR RWY24L/24R

ALISA CHARLIE ARRIVAL BECKY CHARLIE ARRIVAL CANDY CHARLIE ARRIVAL	RNAV1
---	-------

Note 1) DME/DME/IRU or GNSS required.
2) RADAR service required.

VAR 8° W

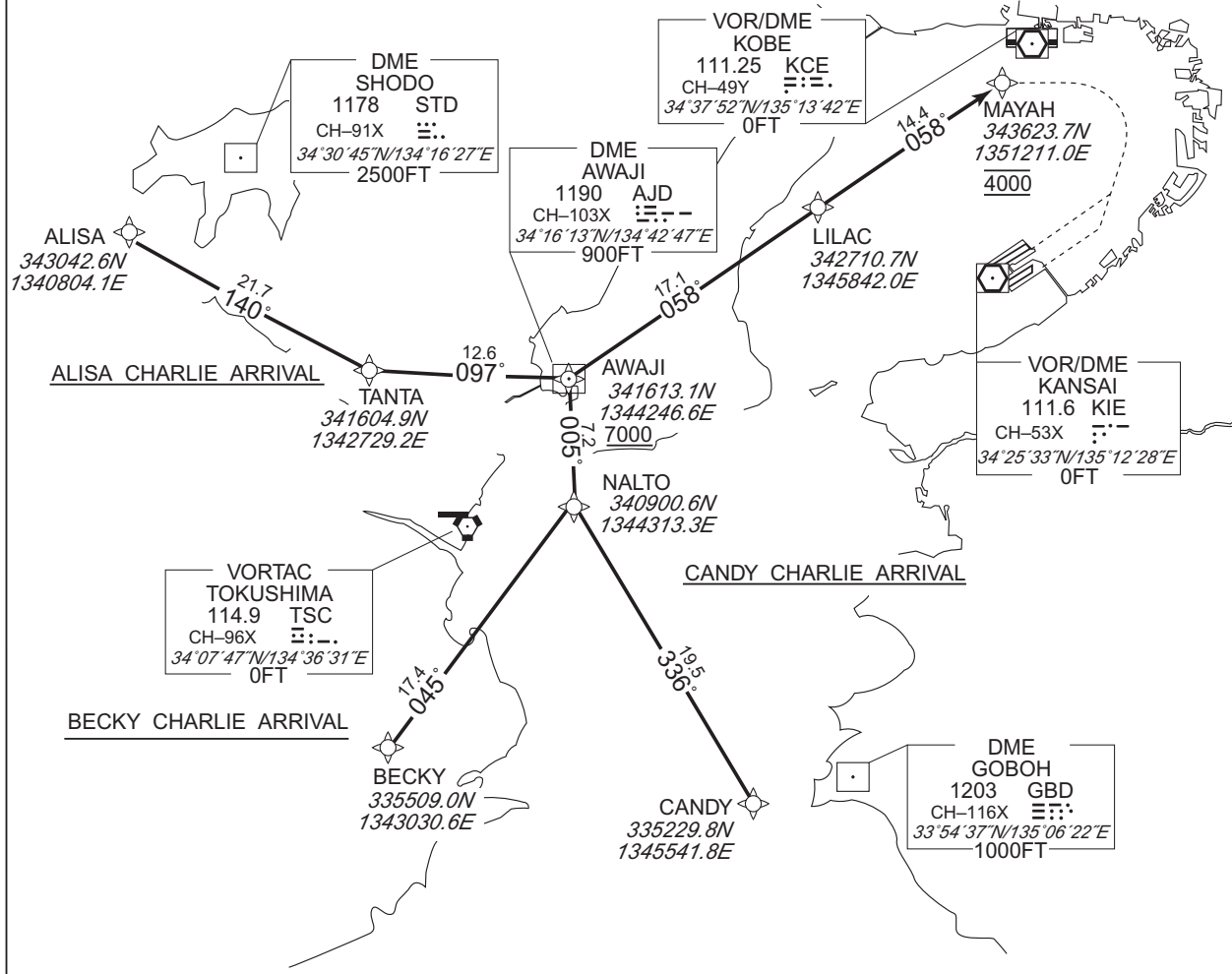

CHANGE : Description of VAR.

NOT TO SCALE	NOT TO SCALE	NOT TO SCALE	NOT TO SCALE
MAX 230KIAS(at or below FL140) MAX 240KIAS(above FL140)	MAX 230KIAS(at or below FL140) MAX 240KIAS(above FL140)	MAX 230KIAS(at or below FL140) MAX 240KIAS(above FL140)	MAX 230KIAS(at or below FL140) MAX 240KIAS(above FL140)
<p>ALISA MHA 10000</p>	<p>BECKY MHA 8000</p>	<p>CANDY MHA 9000</p>	<p>LILAC MHA 3000</p>
1MIN(at or below FL140) 1.5MIN(above FL140)	1MIN(at or below FL140) 1.5MIN(above FL140)	1MIN(at or below FL140) 1.5MIN(above FL140)	1MIN(at or below FL140) 1.5MIN(above FL140)

STANDARD ARRIVAL CHART - INSTRUMENT

RJBB / KANSAI INTL

RNAV STAR RWY24L/24R

ALISA CHARLIE ARRIVAL

From ALISA, to TANTA, to AWAJI at or above 7000FT, to LILAC, to MAYAH at 4000FT.

Critical DME	—
DME GAP	—
Inappropriate Nav aids	See AD1.1.6.10.3. Inappropriate NAVAIDs for RNAV1

Serial Number	Path Descriptor	Waypoint Identifier	Fly Over	Course [°M(°T)]	Magnetic Variation	Distance (NM)	Turn Direction	Altitude (FT)	Speed (KIAS)	Vertical Angle	Navigation Specification
001	IF	ALISA	—	—	-8.0	—	—	—	—	—	RNAV1
002	TF	TANTA	—	140 (132.3)	-8.0	21.7	—	—	—	—	RNAV1
003	TF	AWAJI	—	097 (089.3)	-8.0	12.6	—	+7000	—	—	RNAV1
004	TF	LILAC	—	058 (050.1)	-8.0	17.1	—	—	—	—	RNAV1
005	TF	MAYAH	—	058 (050.3)	-8.0	14.4	—	4000	—	—	RNAV1

Path	Waypoint Identifier	Inbound Course °M(°T)	Magnetic Variation	Outbound Time (MIN)	Outbound Distance (NM)	Turn Direction	Minimum Altitude (FT)	Maximum Altitude (FT)	Speed (KIAS)	Navigation Specification
Hold	ALISA	142 (134.0)	-8.0	1.0(-14000) 1.5(+14001)	—	R	10000	—	-230(-14000) -240(+14001)	RNAV1
Hold	LILAC	057 (049.2)	-8.0	1.0(-14000) 1.5(+14001)	—	R	3000	—	-230(-14000) -240(+14001)	RNAV1

BECKY CHARLIE ARRIVAL

From BECKY, to NALTO, to AWAJI at or above 7000FT, to LILAC, to MAYAH at 4000FT.

Critical DME	—
DME GAP	—
Inappropriate Nav aids	See AD1.1.6.10.3. Inappropriate NAVAIDs for RNAV1

Serial Number	Path Descriptor	Waypoint Identifier	Fly Over	Course [°M(°T)]	Magnetic Variation	Distance (NM)	Turn Direction	Altitude (FT)	Speed (KIAS)	Vertical Angle	Navigation Specification
001	IF	BECKY	—	—	-8.0	—	—	—	—	—	RNAV1
002	TF	NALTO	—	045 (037.2)	-8.0	17.4	—	—	—	—	RNAV1
003	TF	AWAJI	—	005 (357.1)	-8.0	7.2	—	+7000	—	—	RNAV1
004	TF	LILAC	—	058 (050.1)	-8.0	17.1	—	—	—	—	RNAV1
005	TF	MAYAH	—	058 (050.3)	-8.0	14.4	—	4000	—	—	RNAV1

Path	Waypoint Identifier	Inbound Course °M(°T)	Magnetic Variation	Outbound Time (MIN)	Outbound Distance (NM)	Turn Direction	Minimum Altitude (FT)	Maximum Altitude (FT)	Speed (KIAS)	Navigation Specification
Hold	BECKY	058 (050.2)	-8.0	1.0(-14000) 1.5(+14001)	—	R	8000	—	-230(-14000) -240(+14001)	RNAV1
Hold	LILAC	057 (049.2)	-8.0	1.0(-14000) 1.5(+14001)	—	R	3000	—	-230(-14000) -240(+14001)	RNAV1

CHANGE : Critical DME deleted.

STANDARD ARRIVAL CHART - INSTRUMENT

RJBB / KANSAI INTL

RNAV STAR RWY24L/24R

CANDY CHARLIE ARRIVAL

From CANDY, to NALTO, to AWAJI at or above 7000FT, to LILAC, to MAYAH at 4000FT.

Critical DME	—
DME GAP	—
Inappropriate Nav aids	See AD1.1.6.10.3. Inappropriate NAVAIDs for RNAV1

Serial Number	Path Descriptor	Waypoint Identifier	Fly Over	Course [°M(°T)]	Magnetic Variation	Distance (NM)	Turn Direction	Altitude (FT)	Speed (KIAS)	Vertical Angle	Navigation Specification
001	IF	CANDY	—	—	-8.0	—	—	—	—	—	RNAV1
002	TF	NALTO	—	336 (328.0)	-8.0	19.5	—	—	—	—	RNAV1
003	TF	AWAJI	—	005 (357.1)	-8.0	7.2	—	+7000	—	—	RNAV1
004	TF	LILAC	—	058 (050.1)	-8.0	17.1	—	—	—	—	RNAV1
005	TF	MAYAH	—	058 (050.3)	-8.0	14.4	—	4000	—	—	RNAV1

Path	Waypoint Identifier	Inbound Course °M(°T)	Magnetic Variation	Outbound Time (MIN)	Outbound Distance (NM)	Turn Direction	Minimum Altitude (FT)	Maximum Altitude (FT)	Speed (KIAS)	Navigation Specification
Hold	CANDY	322 (313.8)	-8.0	1.0(-14000) 1.5(+14001)	—	L	9000	—	-230(-14000) -240(+14001)	RNAV1
Hold	LILAC	057 (049.2)	-8.0	1.0(-14000) 1.5(+14001)	—	R	3000	—	-230(-14000) -240(+14001)	RNAV1

CHANGE : Critical DME deleted.

STANDARD ARRIVAL CHART - INSTRUMENT

RJBB / KANSAI INTL

RNAV STAR RWY06L/06R

BERTH ALFA / BRAVO ARRIVAL RNAV1

Note 1) DME/DME/IRU or GNSS required.
2) RADAR service required.

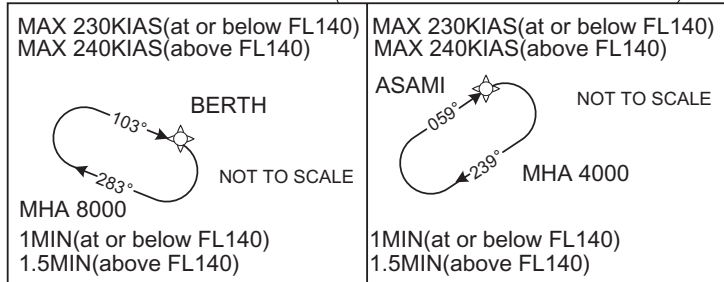
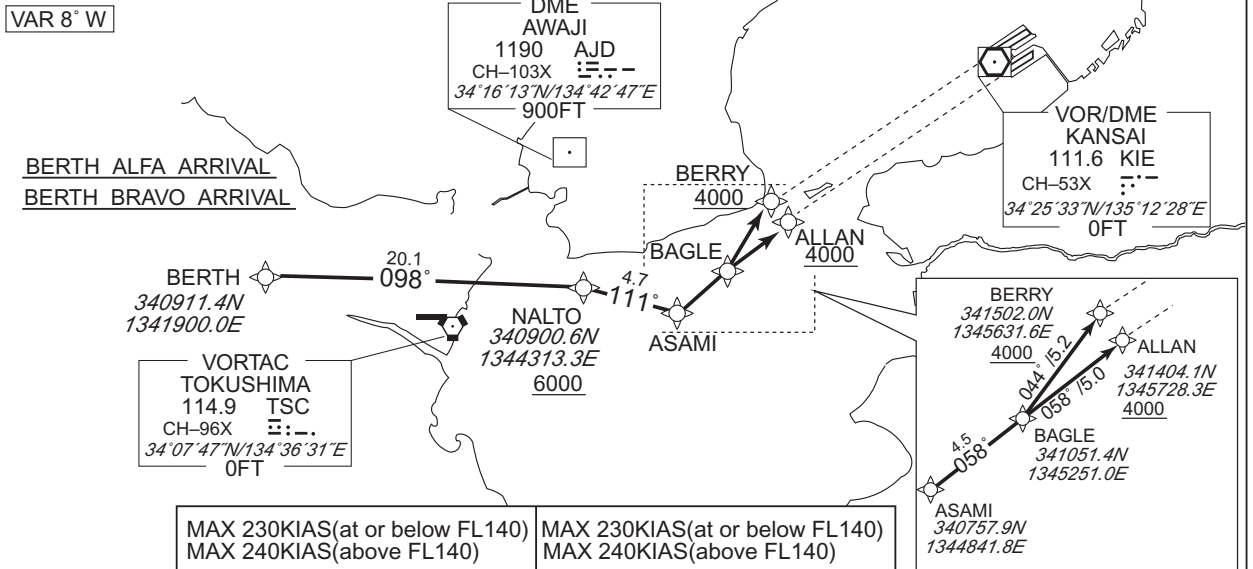

BERTH ALFA ARRIVAL

From BERTH, to NALTO at or above 6000FT, to ASAMI, to BAGLE, to ALLAN at or above 4000FT.

Critical DME	AJD : 8.1NM to NALTO - 5.1NM to NALTO
DME GAP	-
Inappropriate Nav aids	See AD1.1.6.10.3. Inappropriate NAVAIDs for RNAV1

CHANGE : Description of VAR.

Serial Number	Path Descriptor	Waypoint Identifier	Fly Over	Course [°M(°T)]	Magnetic Variation	Distance (NM)	Turn Direction	Altitude (FT)	Speed (KIAS)	Vertical Angle	Navigation Specification
001	IF	BERTH	-	-	-8.0	-	-	-	-	-	RNAV1
002	TF	NALTO	-	098 (090.4)	-8.0	20.1	-	+6000	-	-	RNAV1
003	TF	ASAMI	-	111 (103.0)	-8.0	4.7	-	-	-	-	RNAV1
004	TF	BAGLE	-	058 (049.9)	-8.0	4.5	-	-	-	-	RNAV1
005	TF	ALLAN	-	058 (049.9)	-8.0	5.0	-	+4000	-	-	RNAV1

Path	Waypoint Identifier	Inbound Course °M(°T)	Magnetic Variation	Outbound Time (MIN)	Outbound Distance (NM)	Turn Direction	Minimum Altitude (FT)	Maximum Altitude (FT)	Speed (KIAS)	Navigation Specification
Hold	BERTH	103 (095.4)	-8.0	1.0(-14000) 1.5(+14001)	-	R	8000	-	-230(-14000) -240(+14001)	RNAV1
Hold	ASAMI	059 (050.7)	-8.0	1.0(-14000) 1.5(+14001)	-	R	4000	-	-230(-14000) -240(+14001)	RNAV1

STANDARD ARRIVAL CHART - INSTRUMENT

RJBB / KANSAI INTL

RNAV STAR RWY06L/06R

BERTH BRAVO ARRIVAL

From BERTH, to NALTO at or above 6000FT, to ASAMI, to BAGLE, to BERRY at or above 4000FT.

Critical DME	AJD : 8.1NM to NALTO - 5.1NM to NALTO
DME GAP	—
Inappropriate Nav aids	See AD1.1.6.10.3. Inappropriate NAVAIDs for RNAV1

Serial Number	Path Descriptor	Waypoint Identifier	Fly Over	Course [°M(°T)]	Magnetic Variation	Distance (NM)	Turn Direction	Altitude (FT)	Speed (KIAS)	Vertical Angle	Navigation Specification
001	IF	BERTH	—	—	-8.0	—	—	—	—	—	RNAV1
002	TF	NALTO	—	098 (090.4)	-8.0	20.1	—	+6000	—	—	RNAV1
003	TF	ASAMI	—	111 (103.0)	-8.0	4.7	—	—	—	—	RNAV1
004	TF	BAGLE	—	058 (049.9)	-8.0	4.5	—	—	—	—	RNAV1
005	TF	BERRY	—	044 (036.0)	-8.0	5.2	—	+4000	—	—	RNAV1

Path	Waypoint Identifier	Inbound Course °M(°T)	Magnetic Variation	Outbound Time (MIN)	Outbound Distance (NM)	Turn Direction	Minimum Altitude (FT)	Maximum Altitude (FT)	Speed (KIAS)	Navigation Specification
Hold	BERTH	103 (095.4)	-8.0	1.0(-14000) 1.5(+14001)	—	R	8000	—	-230(-14000) -240(+14001)	RNAV1
Hold	ASAMI	059 (050.7)	-8.0	1.0(-14000) 1.5(+14001)	—	R	4000	—	-230(-14000) -240(+14001)	RNAV1

CHANGE : VAR.

STANDARD ARRIVAL CHART - INSTRUMENT

RJBB / KANSAI INTL

RNAV STAR RWY24L/24R

BERTH CHARLIE ARRIVAL RNAV1

Note 1) DME/DME/IRU or GNSS required.
2) RADAR service required.

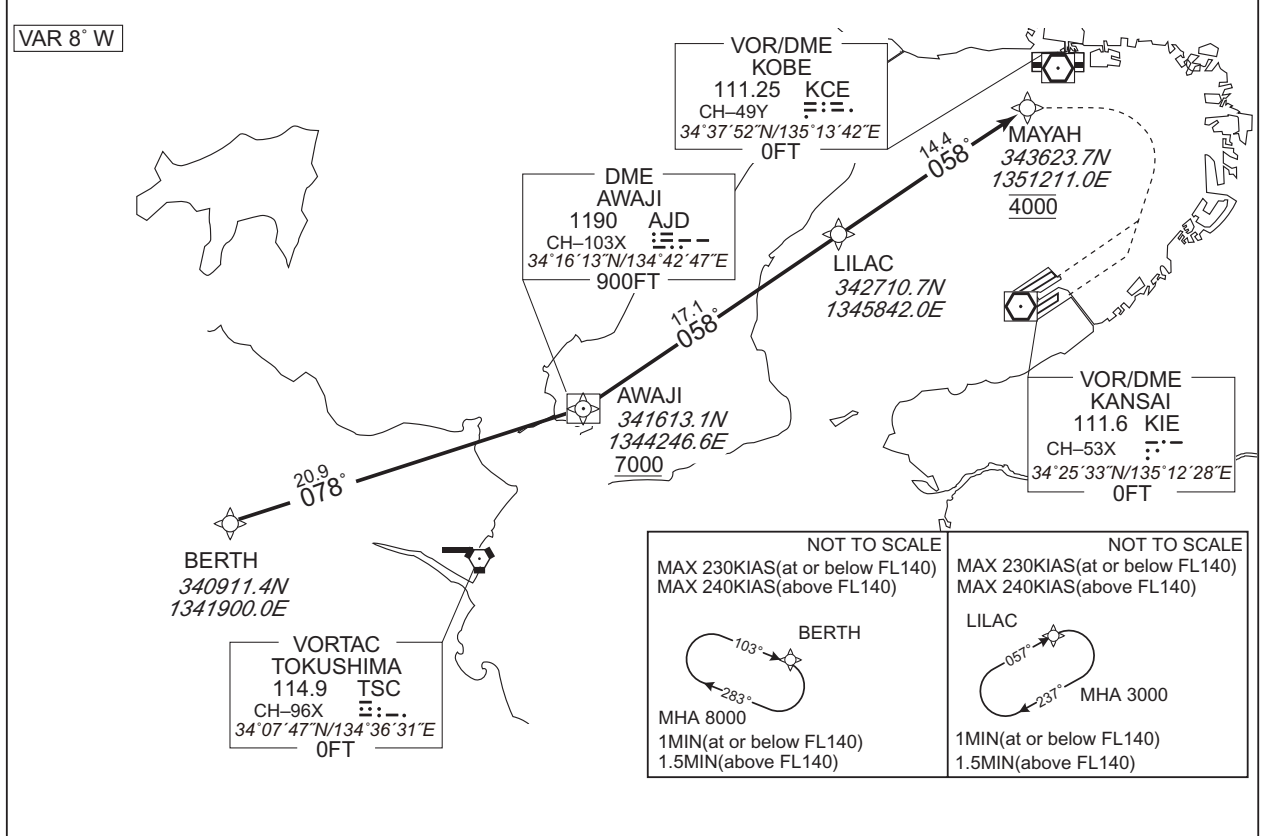

From BERTH, to AWAJI at or above 7000FT, to LILAC, to MAYAH at 4000FT.

Critical DME	—
DME GAP	—
Inappropriate Nav aids	See AD1.1.6.10.3. Inappropriate NAVAIDs for RNAV1

Serial Number	Path Descriptor	Waypoint Identifier	Fly Over	Course [°M(°T)]	Magnetic Variation	Distance (NM)	Turn Direction	Altitude (FT)	Speed (KIAS)	Vertical Angle	Navigation Specification
001	IF	BERTH	—	—	-8.0	—	—	—	—	—	RNAV1
002	TF	AWAJI	—	078 (070.2)	-8.0	20.9	—	+7000	—	—	RNAV1
003	TF	LILAC	—	058 (050.1)	-8.0	17.1	—	—	—	—	RNAV1
004	TF	MAYAH	—	058 (050.3)	-8.0	14.4	—	4000	—	—	RNAV1

Path	Waypoint Identifier	Inbound Course °M(°T)	Magnetic Variation	Outbound Time (MIN)	Outbound Distance (NM)	Turn Direction	Minimum Altitude (FT)	Maximum Altitude (FT)	Speed (KIAS)	Navigation Specification
Hold	BERTH	103 (095.4)	-8.0	1.0(-14000) 1.5(+14001)	—	R	8000	—	-230(-14000) -240(+14001)	RNAV1
Hold	LILAC	057 (049.2)	-8.0	1.0(-14000) 1.5(+14001)	—	R	3000	—	-230(-14000) -240(+14001)	RNAV1

CHANGE : Critical DME deleted.

STANDARD ARRIVAL CHART - INSTRUMENT

RJBB / KANSAI INTL

RNAV STAR RWY06L/06R

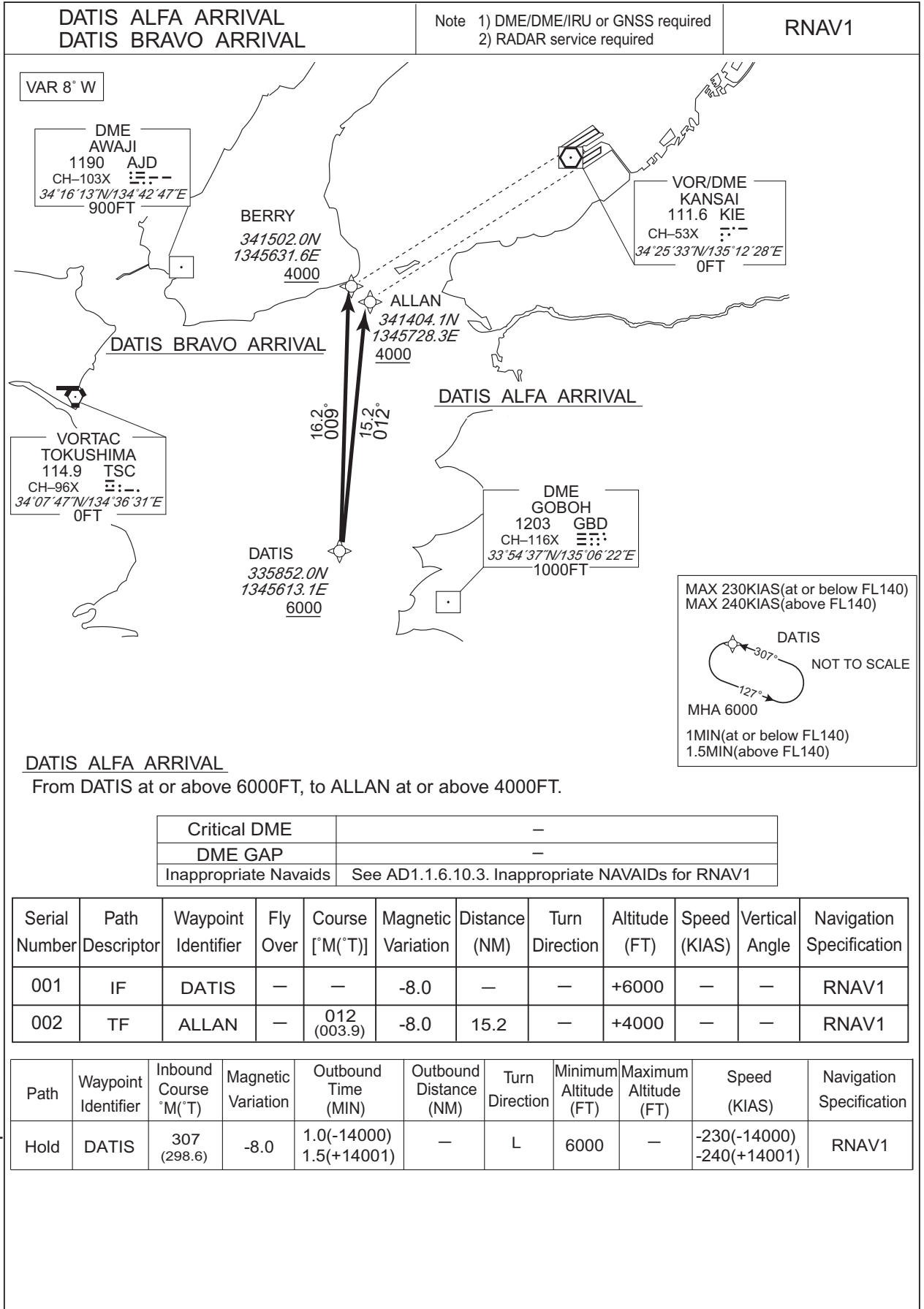

CHANGE : Description of VAR.

STANDARD ARRIVAL CHART - INSTRUMENT

RJBB / KANSAI INTL

RNAV STAR RWY06L/06R

DATIS BRAVO ARRIVAL

From DATIS at or above 6000FT, to BERRY at or above 4000FT.

Critical DME	—
DME GAP	—
Inappropriate Nav aids	See AD1.1.6.10.3. Inappropriate NAVAIDs for RNAV1

Serial Number	Path Descriptor	Waypoint Identifier	Fly Over	Course [°M(°T)]	Magnetic Variation	Distance (NM)	Turn Direction	Altitude (FT)	Speed (KIAS)	Vertical Angle	Navigation Specification
001	IF	DATIS	—	—	-8.0	—	—	+6000	—	—	RNAV1
002	TF	BERRY	—	009 (000.9)	-8.0	16.2	—	+4000	—	—	RNAV1

Path	Waypoint Identifier	Inbound Course °M(°T)	Magnetic Variation	Outbound Time (MIN)	Outbound Distance (NM)	Turn Direction	Minimum Altitude (FT)	Maximum Altitude (FT)	Speed (KIAS)	Navigation Specification
Hold	DATIS	307 (298.6)	-8.0	1.0(-14000) 1.5(+14001)	—	L	6000	—	-230(-14000) -240(+14001)	RNAV1

CHANGE : VAR.

STANDARD ARRIVAL CHART - INSTRUMENT

RJBB / KANSAI INTL

RNAV STAR RWY24L/24R

DATIS CHARLIE ARRIVAL	Note 1) DME/DME/IRU or GNSS required. 2) RADAR service required.	RNAV1
-----------------------	---	-------

VAR 8° W

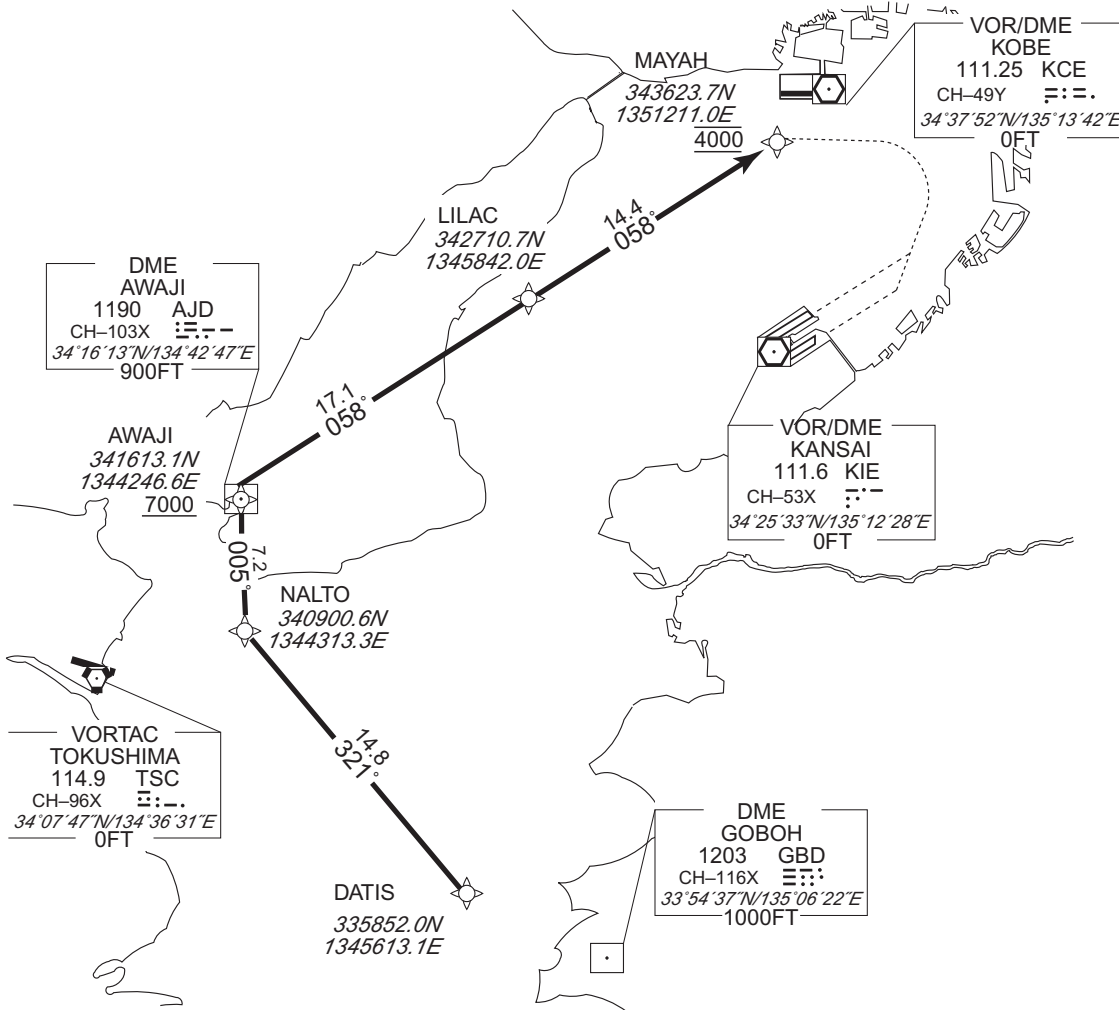

CHANGE : Description of VAR and PROC name.

<p>MAX 230KIAS(at or below FL140) MAX 240KIAS(above FL140)</p> <p>DATIS NOT TO SCALE</p> <p>MHA 6000</p> <p>1MIN(at or below FL140) 1.5MIN(above FL140)</p>	<p>NOT TO SCALE</p> <p>MAX 230KIAS(at or below FL140) MAX 240KIAS(above FL140)</p> <p>LILAC NOT TO SCALE</p> <p>MHA 3000</p> <p>1MIN(at or below FL140) 1.5MIN(above FL140)</p>
---	---

STANDARD ARRIVAL CHART - INSTRUMENT

RJBB / KANSAI INTL

RNAV STAR RWY24L/24R

DATIS CHARLIE ARRIVAL

From DATIS, to NALTO, to AWAJI at or above 7000FT, to LILAC, to MAYAH at 4000FT.

Critical DME	—
DME GAP	—
Inappropriate Nav aids	See AD1.1.6.10.3. Inappropriate NAVAIDs for RNAV1

Serial Number	Path Descriptor	Waypoint Identifier	Fly Over	Course [°M(°T)]	Magnetic Variation	Distance (NM)	Turn Direction	Altitude (FT)	Speed (KIAS)	Vertical Angle	Navigation Specification
001	IF	DATIS	—	—	-8.0	—	—	—	—	—	RNAV1
002	TF	NALTO	—	321 (313.4)	-8.0	14.8	—	—	—	—	RNAV1
003	TF	AWAJI	—	005 (357.1)	-8.0	7.2	—	+7000	—	—	RNAV1
004	TF	LILAC	—	058 (050.1)	-8.0	17.1	—	—	—	—	RNAV1
005	TF	MAYAH	—	058 (050.3)	-8.0	14.4	—	4000	—	—	RNAV1

Path	Waypoint Identifier	Inbound Course °M(°T)	Magnetic Variation	Outbound Time (MIN)	Outbound Distance (NM)	Turn Direction	Minimum Altitude (FT)	Maximum Altitude (FT)	Speed (KIAS)	Navigation Specification
Hold	DATIS	307 (298.6)	-8.0	1.0(-14000) 1.5(+14001)	—	L	6000	—	-230(-14000) -240(+14001)	RNAV1
Hold	LILAC	057 (049.2)	-8.0	1.0(-14000) 1.5(+14001)	—	R	3000	—	-230(-14000) -240(+14001)	RNAV1

CHANGE : Critical DME deleted.

STANDARD ARRIVAL CHART - INSTRUMENT

RJBB / KANSAI INTL

RNAV STAR RWY24L/24R

ALISA DELTA ARRIVAL BECKY DELTA ARRIVAL BERTH DELTA ARRIVAL CANDY DELTA ARRIVAL	RNAV1
--	-------

Note 1) DME/DME/IRU or GNSS required.
2) RADAR service required.

VAR 8° W

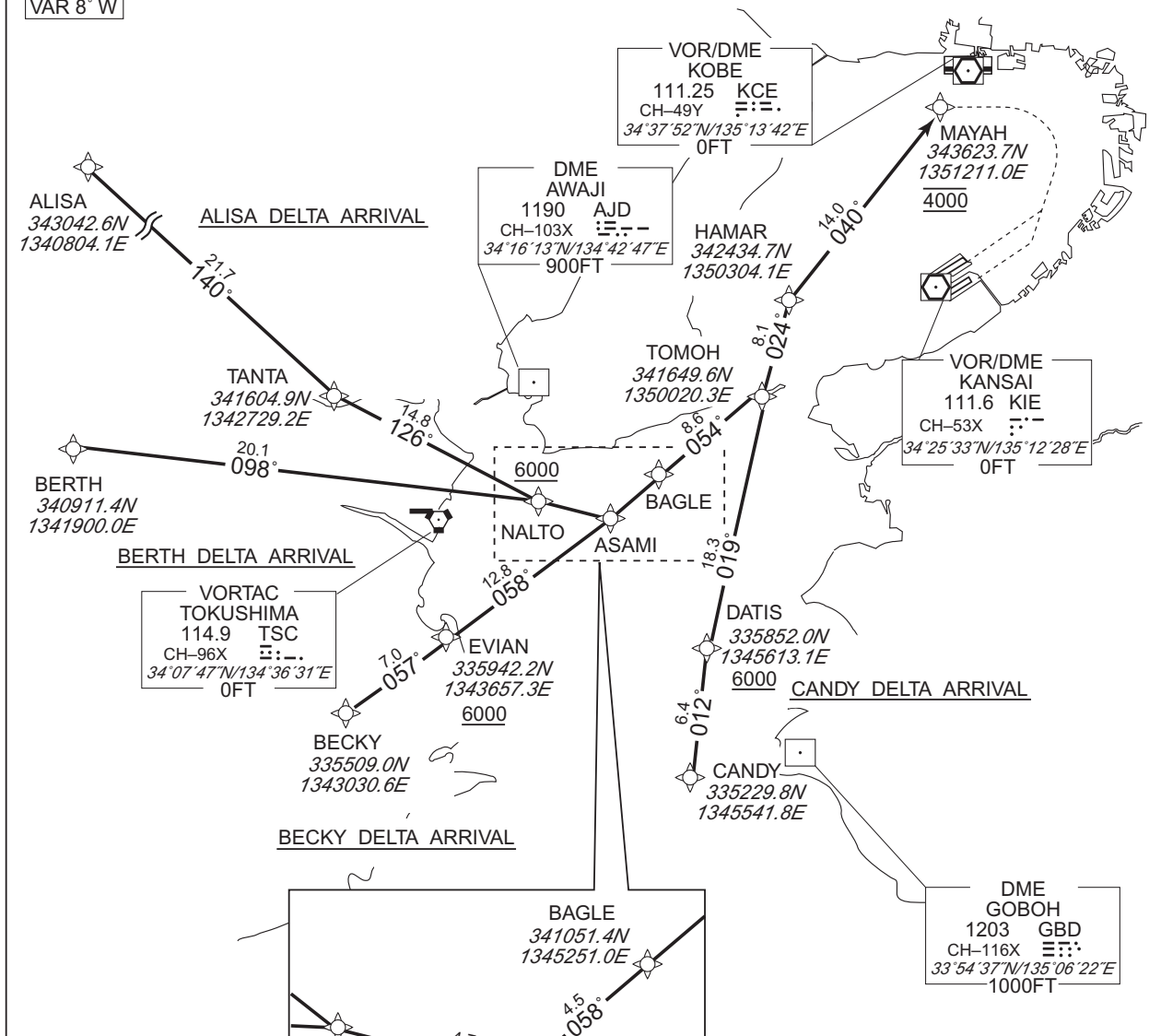

CHANGE : Description of VAR.

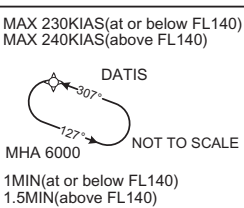
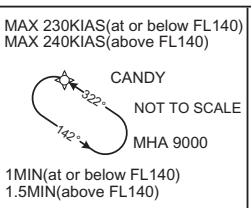
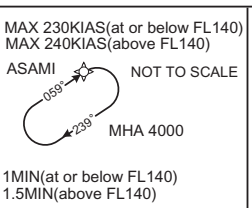
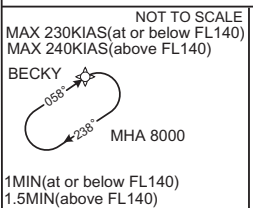
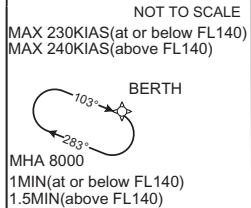
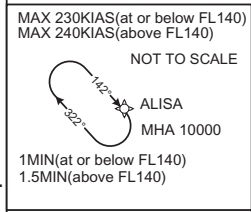

STANDARD ARRIVAL CHART - INSTRUMENT

RJBB / KANSAI INTL

RNAV STAR RWY24L/24R

ALISA DELTA ARRIVAL

From ALISA, to TANTA, to NALTO at or above 6000FT, to ASAMI, to BAGLE, to TOMOH, to HAMAR, to MAYAH at 4000FT.

Critical DME	AJD : 2.0NM to MAYAH - MAYAH GBD : 7.1NM to HAMAR - 5.1NM to HAMAR
DME GAP	—
Inappropriate Nav aids	See AD1.1.6.10.3. Inappropriate NAVAIDs for RNAV1

Serial Number	Path Descriptor	Waypoint Identifier	Fly Over	Course [°M(°T)]	Magnetic Variation	Distance (NM)	Turn Direction	Altitude (FT)	Speed (KIAS)	Vertical Angle	Navigation Specification
001	IF	ALISA	—	—	-8.0	—	—	—	—	—	RNAV1
002	TF	TANTA	—	140 (132.3)	-8.0	21.7	—	—	—	—	RNAV1
003	TF	NALTO	—	126 (118.4)	-8.0	14.8	—	+6000	—	—	RNAV1
004	TF	ASAMI	—	111 (103.0)	-8.0	4.7	—	—	—	—	RNAV1
005	TF	BAGLE	—	058 (049.9)	-8.0	4.5	—	—	—	—	RNAV1
006	TF	TOMOH	—	054 (046.0)	-8.0	8.6	—	—	—	—	RNAV1
007	TF	HAMAR	—	024 (016.2)	-8.0	8.1	—	—	—	—	RNAV1
008	TF	MAYAH	—	040 (032.4)	-8.0	14.0	—	4000	—	—	RNAV1

Path	Waypoint Identifier	Inbound Course °M(°T)	Magnetic Variation	Outbound Time (MIN)	Outbound Distance (NM)	Turn Direction	Minimum Altitude (FT)	Maximum Altitude (FT)	Speed (KIAS)	Navigation Specification
Hold	ALISA	142 (134.0)	-8.0	1.0(-14000) 1.5(+14001)	—	R	10000	—	-230(-14000) -240(+14001)	RNAV1
Hold	ASAMI	059 (050.7)	-8.0	1.0(-14000) 1.5(+14001)	—	R	4000	—	-230(-14000) -240(+14001)	RNAV1

CHANGE : VAR.

STANDARD ARRIVAL CHART - INSTRUMENT

RJBB / KANSAI INTL

RNAV STAR RWY24L/24R

BECKY DELTA ARRIVAL

From BECKY, to EVIAN at or above 6000FT, to ASAMI, to BAGLE, to TOMOH, to HAMAR, to MAYAH at 4000FT.

Critical DME	GBD : 7.1NM to HAMAR - 5.1NM to HAMAR AJD : 2.0NM to MAYAH - MAYAH
DME GAP	-
Inappropriate Nav aids	See AD1.1.6.10.3. Inappropriate NAVAIDs for RNAV1

Serial Number	Path Descriptor	Waypoint Identifier	Fly Over	Course [°M(°T)]	Magnetic Variation	Distance (NM)	Turn Direction	Altitude (FT)	Speed (KIAS)	Vertical Angle	Navigation Specification
001	IF	BECKY	-	-	-8.0	-	-	-	-	-	RNAV1
002	TF	EVIAN	-	057 (049.5)	-8.0	7.0	-	+6000	-	-	RNAV1
003	TF	ASAMI	-	058 (049.6)	-8.0	12.8	-	-	-	-	RNAV1
004	TF	BAGLE	-	058 (049.9)	-8.0	4.5	-	-	-	-	RNAV1
005	TF	TOMOH	-	054 (046.0)	-8.0	8.6	-	-	-	-	RNAV1
006	TF	HAMAR	-	024 (016.2)	-8.0	8.1	-	-	-	-	RNAV1
007	TF	MAYAH	-	040 (032.4)	-8.0	14.0	-	4000	-	-	RNAV1

Path	Waypoint Identifier	Inbound Course °M(°T)	Magnetic Variation	Outbound Time (MIN)	Outbound Distance (NM)	Turn Direction	Minimum Altitude (FT)	Maximum Altitude (FT)	Speed (KIAS)	Navigation Specification
Hold	BECKY	058 (050.2)	-8.0	1.0(-14000) 1.5(+14001)	-	R	8000	-	-230(-14000) -240(+14001)	RNAV1
Hold	ASAMI	059 (050.7)	-8.0	1.0(-14000) 1.5(+14001)	-	R	4000	-	-230(-14000) -240(+14001)	RNAV1

CHANGE : VAR. Course FM EVIAN to ASAMI.

STANDARD ARRIVAL CHART - INSTRUMENT

RJBB / KANSAI INTL

RNAV STAR RWY24L/24R

BERTH DELTA ARRIVAL

From BERTH to NALTO at or above 6000FT, to ASAMI, to BAGLE, to TOMOH, to HAMAR, to MAYAH at 4000FT.

Critical DME	AJD : 8.1NM to NALTO - 5.1NM to NALTO 2.0NM to MAYAH - MAYAH GBD : 7.1NM to HAMAR - 5.1NM to HAMAR
DME GAP	—
Inappropriate Nav aids	See AD1.1.6.10.3. Inappropriate NAVAIDs for RNAV1

Serial Number	Path Descriptor	Waypoint Identifier	Fly Over	Course [°M(°T)]	Magnetic Variation	Distance (NM)	Turn Direction	Altitude (FT)	Speed (KIAS)	Vertical Angle	Navigation Specification
001	IF	BERTH	—	—	-8.0	—	—	—	—	—	RNAV1
002	TF	NALTO	—	098 (090.4)	-8.0	20.1	—	+6000	—	—	RNAV1
003	TF	ASAMI	—	111 (103.0)	-8.0	4.7	—	—	—	—	RNAV1
004	TF	BAGLE	—	058 (049.9)	-8.0	4.5	—	—	—	—	RNAV1
005	TF	TOMOH	—	054 (046.0)	-8.0	8.6	—	—	—	—	RNAV1
006	TF	HAMAR	—	024 (016.2)	-8.0	8.1	—	—	—	—	RNAV1
007	TF	MAYAH	—	040 (032.4)	-8.0	14.0	—	4000	—	—	RNAV1

Path	Waypoint Identifier	Inbound Course °M(°T)	Magnetic Variation	Outbound Time (MIN)	Outbound Distance (NM)	Turn Direction	Minimum Altitude (FT)	Maximum Altitude (FT)	Speed (KIAS)	Navigation Specification
Hold	BERTH	103 (095.4)	-8.0	1.0(-14000) 1.5(+14001)	—	R	8000	—	-230(-14000) -240(+14001)	RNAV1
Hold	ASAMI	059 (050.7)	-8.0	1.0(-14000) 1.5(+14001)	—	R	4000	—	-230(-14000) -240(+14001)	RNAV1

CHANGE : VAR.

STANDARD ARRIVAL CHART - INSTRUMENT

RJBB / KANSAI INTL

RNAV STAR RWY24L/24R

CANDY DELTA ARRIVAL

From CANDY, to DATIS at or above 6000FT, to TOMOH, to HAMAR, to MAYAH at 4000FT.

Critical DME	GBD : 7.1NM to HAMAR - 5.1NM to HAMAR AJD : 2.0NM to MAYAH - MAYAH
DME GAP	—
Inappropriate Nav aids	See AD1.1.6.10.3. Inappropriate NAVAIDS for RNAV1

Serial Number	Path Descriptor	Waypoint Identifier	Fly Over	Course [°M(°T)]	Magnetic Variation	Distance (NM)	Turn Direction	Altitude (FT)	Speed (KIAS)	Vertical Angle	Navigation Specification
001	IF	CANDY	—	—	-8.0	—	—	—	—	—	RNAV1
002	TF	DATIS	—	012 (003.9)	-8.0	6.4	—	+6000	—	—	RNAV1
003	TF	TOMOH	—	019 (010.7)	-8.0	18.3	—	—	—	—	RNAV1
004	TF	HAMAR	—	024 (016.2)	-8.0	8.1	—	—	—	—	RNAV1
005	TF	MAYAH	—	040 (032.4)	-8.0	14.0	—	4000	—	—	RNAV1

Path	Waypoint Identifier	Inbound Course °M(°T)	Magnetic Variation	Outbound Time (MIN)	Outbound Distance (NM)	Turn Direction	Minimum Altitude (FT)	Maximum Altitude (FT)	Speed (KIAS)	Navigation Specification
Hold	CANDY	322 (313.8)	-8.0	1.0(-14000) 1.5(+14001)	—	L	9000	—	-230(-14000) -240(+14001)	RNAV1
Hold	DATIS	307 (298.6)	-8.0	1.0(-14000) 1.5(+14001)	—	L	6000	—	-230(-14000) -240(+14001)	RNAV1

CHANGE : VAR.

STANDARD ARRIVAL CHART - INSTRUMENT

RJBB / KANSAI INTL

RNAV STAR RWY24L/24R

ALISA ECHO ARRIVAL BECKY ECHO ARRIVAL BERTH ECHO ARRIVAL CANDY ECHO ARRIVAL	RNAV1
--	-------

Note 1) DME/DME/IRU or GNSS required
2) RADAR service required

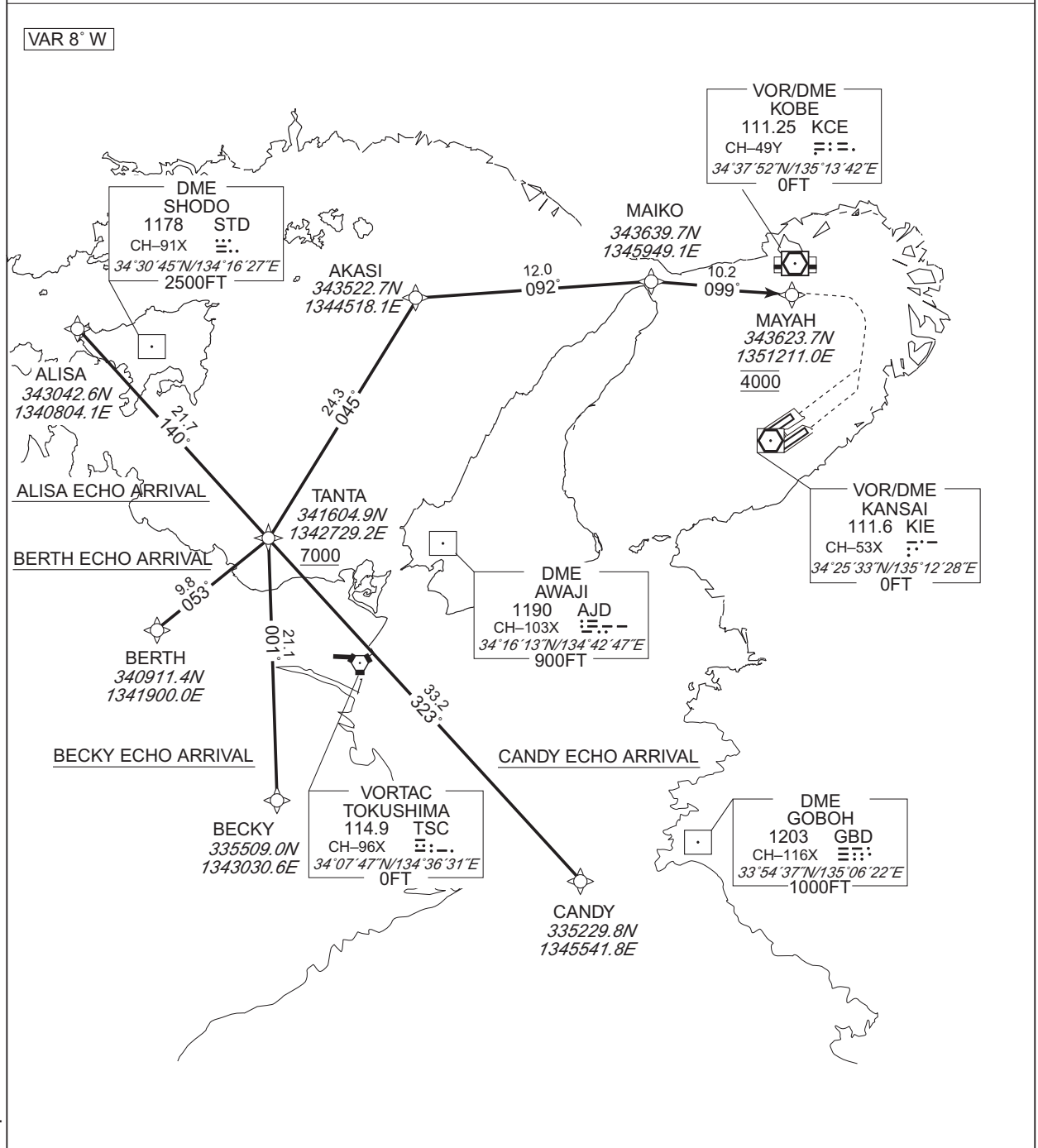

CHANGE : Description of VAR.

MAX 230KIAS(at or below FL140) MAX 240KIAS(above FL140) NOT TO SCALE ALISA MHA 10000 1MIN(at or below FL140) 1.5MIN(above FL140)	MAX 230KIAS(at or below FL140) MAX 240KIAS(above FL140) NOT TO SCALE BERTH MHA 8000 NOT TO SCALE 1MIN(at or below FL140) 1.5MIN(above FL140)	MAX 230KIAS(at or below FL140) MAX 240KIAS(above FL140) NOT TO SCALE BECKY MHA 8000 NOT TO SCALE 1MIN(at or below FL140) 1.5MIN(above FL140)	MAX 230KIAS(at or below FL140) MAX 240KIAS(above FL140) NOT TO SCALE AKASI MHA 4000 NOT TO SCALE 1MIN(at or below FL140) 1.5MIN(above FL140)	MAX 230KIAS(at or below FL140) MAX 240KIAS(above FL140) NOT TO SCALE CANDY MHA 9000 NOT TO SCALE 1MIN(at or below FL140) 1.5MIN(above FL140)
--	---	---	---	---

STANDARD ARRIVAL CHART - INSTRUMENT

RJBB / KANSAI INTL

RNAV STAR RWY24L/24R

ALISA ECHO ARRIVAL

From ALISA, to TANTA at or above 7000FT, to AKASI, to MAIKO, to MAYAH at 4000FT.

Critical DME	KTE : TANTA - 18.3NM to AKASI AJD : 14.3NM to AKASI - 9.3NM to AKASI
DME GAP	—
Inappropriate Nav aids	See AD1.1.6.10.3. Inappropriate NAVAIDs for RNAV1

Serial Number	Path Descriptor	Waypoint Identifier	Fly Over	Course [°M(°T)]	Magnetic Variation	Distance (NM)	Turn Direction	Altitude (FT)	Speed (KIAS)	Vertical Angle	Navigation Specification
001	IF	ALISA	—	—	-8.0	—	—	—	—	—	RNAV1
002	TF	TANTA	—	140 (132.3)	-8.0	21.7	—	+7000	—	—	RNAV1
003	TF	AKASI	—	045 (037.2)	-8.0	24.3	—	—	—	—	RNAV1
004	TF	MAIKO	—	092 (083.8)	-8.0	12.0	—	—	—	—	RNAV1
005	TF	MAYAH	—	099 (091.4)	-8.0	10.2	—	4000	—	—	RNAV1

Path	Waypoint Identifier	Inbound Course °M(°T)	Magnetic Variation	Outbound Time (MIN)	Outbound Distance (NM)	Turn Direction	Minimum Altitude (FT)	Maximum Altitude (FT)	Speed (KIAS)	Navigation Specification
Hold	ALISA	142 (134.0)	-8.0	1.0(-14000) 1.5(+14001)	—	R	10000	—	-230(-14000) -240(+14001)	RNAV1
Hold	AKASI	092 (083.8)	-8.0	1.0(-14000) 1.5(+14001)	—	R	4000	—	-230(-14000) -240(+14001)	RNAV1

BECKY ECHO ARRIVAL

From BECKY, to TANTA at or above 7000FT, to AKASI, to MAIKO, to MAYAH at 4000FT.

Critical DME	KTE : TANTA - 18.3NM to AKASI AJD : 14.3NM to AKASI - 9.3NM to AKASI
DME GAP	—
Inappropriate Nav aids	See AD1.1.6.10.3. Inappropriate NAVAIDs for RNAV1

Serial Number	Path Descriptor	Waypoint Identifier	Fly Over	Course [°M(°T)]	Magnetic Variation	Distance (NM)	Turn Direction	Altitude (FT)	Speed (KIAS)	Vertical Angle	Navigation Specification
001	IF	BECKY	—	—	-8.0	—	—	—	—	—	RNAV1
002	TF	TANTA	—	001 (353.2)	-8.0	21.1	—	+7000	—	—	RNAV1
003	TF	AKASI	—	045 (037.2)	-8.0	24.3	—	—	—	—	RNAV1
004	TF	MAIKO	—	092 (083.8)	-8.0	12.0	—	—	—	—	RNAV1
005	TF	MAYAH	—	099 (091.4)	-8.0	10.2	—	4000	—	—	RNAV1

Path	Waypoint Identifier	Inbound Course °M(°T)	Magnetic Variation	Outbound Time (MIN)	Outbound Distance (NM)	Turn Direction	Minimum Altitude (FT)	Maximum Altitude (FT)	Speed (KIAS)	Navigation Specification
Hold	BECKY	058 (050.2)	-8.0	1.0(-14000) 1.5(+14001)	—	R	8000	—	-230(-14000) -240(+14001)	RNAV1
Hold	AKASI	092 (083.8)	-8.0	1.0(-14000) 1.5(+14001)	—	R	4000	—	-230(-14000) -240(+14001)	RNAV1

CHANGE : Minimum ALT at AKASI.

STANDARD ARRIVAL CHART - INSTRUMENT

RJBB / KANSAI INTL

RNAV STAR RWY24L/24R

BERTH ECHO ARRIVAL

From BERTH, to TANTA at or above 7000FT, to AKASI, to MAIKO, to MAYAH at 4000FT.

Critical DME	KTE : TANTA - 18.3NM to AKASI AJD : 14.3NM to AKASI - 9.3NM to AKASI
DME GAP	—
Inappropriate Nav aids	See AD1.1.6.10.3. Inappropriate NAVAIDs for RNAV1

Serial Number	Path Descriptor	Waypoint Identifier	Fly Over	Course [°M(°T)]	Magnetic Variation	Distance (NM)	Turn Direction	Altitude (FT)	Speed (KIAS)	Vertical Angle	Navigation Specification
001	IF	BERTH	—	—	-8.0	—	—	—	—	—	RNAV1
002	TF	TANTA	—	053 (045.5)	-8.0	9.8	—	+7000	—	—	RNAV1
003	TF	AKASI	—	045 (037.2)	-8.0	24.3	—	—	—	—	RNAV1
004	TF	MAIKO	—	092 (083.8)	-8.0	12.0	—	—	—	—	RNAV1
005	TF	MAYAH	—	099 (091.4)	-8.0	10.2	—	4000	—	—	RNAV1

Path	Waypoint Identifier	Inbound Course °M(°T)	Magnetic Variation	Outbound Time (MIN)	Outbound Distance (NM)	Turn Direction	Minimum Altitude (FT)	Maximum Altitude (FT)	Speed (KIAS)	Navigation Specification
Hold	BERTH	103 (095.4)	-8.0	1.0(-14000) 1.5(+14001)	—	R	8000	—	-230(-14000) -240(+14001)	RNAV1
Hold	AKASI	092 (083.8)	-8.0	1.0(-14000) 1.5(+14001)	—	R	4000	—	-230(-14000) -240(+14001)	RNAV1

CANDY ECHO ARRIVAL

From CANDY, to TANTA at or above 7000FT, to AKASI, to MAIKO, to MAYAH at 4000FT.

Critical DME	KTE : TANTA - 18.3NM to AKASI AJD : 14.3NM to AKASI - 9.3NM to AKASI
DME GAP	—
Inappropriate Nav aids	See AD1.1.6.10.3. Inappropriate NAVAIDs for RNAV1

Serial Number	Path Descriptor	Waypoint Identifier	Fly Over	Course [°M(°T)]	Magnetic Variation	Distance (NM)	Turn Direction	Altitude (FT)	Speed (KIAS)	Vertical Angle	Navigation Specification
001	IF	CANDY	—	—	-8.0	—	—	—	—	—	RNAV1
002	TF	TANTA	—	323 (315.4)	-8.0	33.2	—	+7000	—	—	RNAV1
003	TF	AKASI	—	045 (037.2)	-8.0	24.3	—	—	—	—	RNAV1
004	TF	MAIKO	—	092 (083.8)	-8.0	12.0	—	—	—	—	RNAV1
005	TF	MAYAH	—	099 (091.4)	-8.0	10.2	—	4000	—	—	RNAV1

Path	Waypoint Identifier	Inbound Course °M(°T)	Magnetic Variation	Outbound Time (MIN)	Outbound Distance (NM)	Turn Direction	Minimum Altitude (FT)	Maximum Altitude (FT)	Speed (KIAS)	Navigation Specification
Hold	CANDY	322 (313.8)	-8.0	1.0(-14000) 1.5(+14001)	—	L	9000	—	-230(-14000) -240(+14001)	RNAV1
Hold	AKASI	092 (083.8)	-8.0	1.0(-14000) 1.5(+14001)	—	R	4000	—	-230(-14000) -240(+14001)	RNAV1

CHANGE : Minimum ALT at AKASI.

INSTRUMENT APPROACH CHART

RJBB / KANSAI INTL ILS Z or LOC Z RWY06L (CAT II)

KANSAI APP 120.25 - 125.5 258.3	ILS - LOC 108.7 IKJ ILS-GP 330.5 ILS-DME CH-24X	KANSAI TOWER 118.2 - 118.05 126.2 - 236.8	RADAR AVBL ATIS 127.85
---------------------------------------	--	---	---------------------------

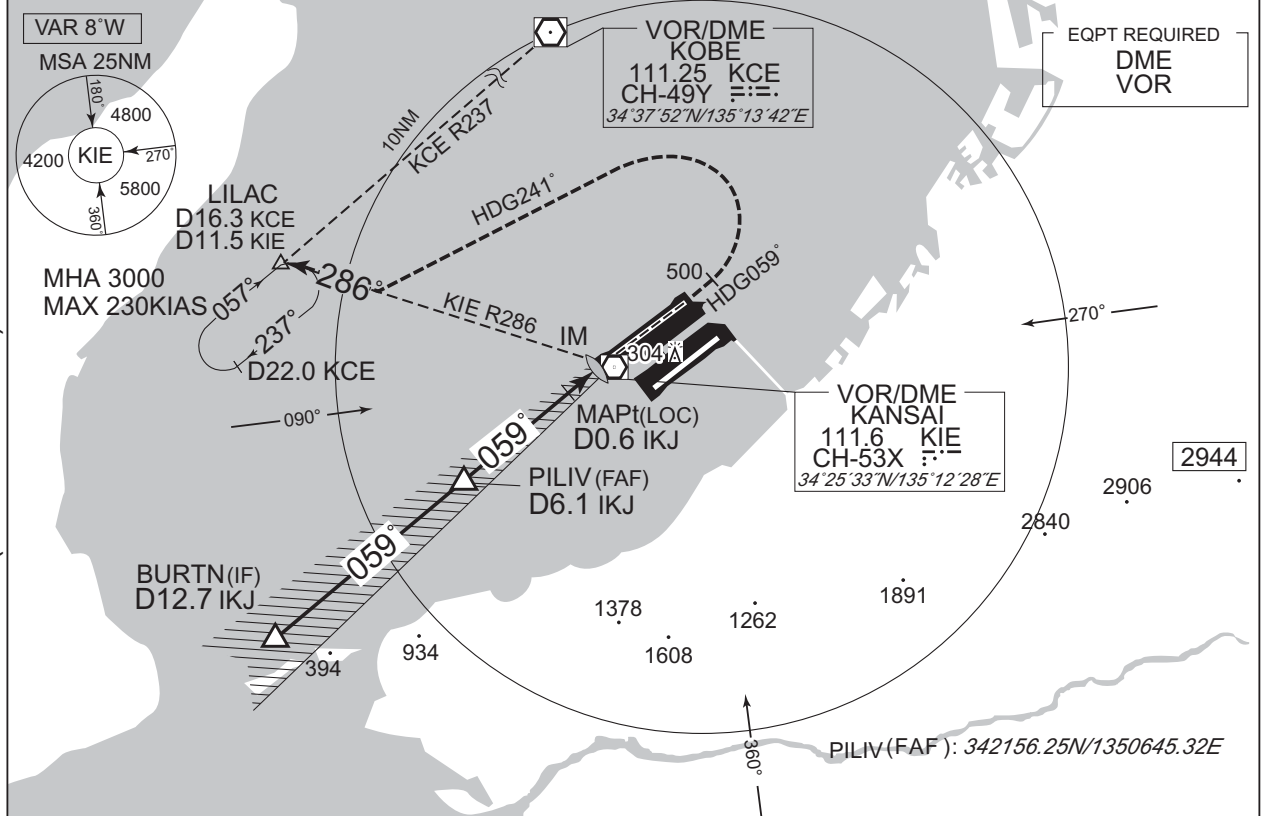

CHANGE : PILIV established. LUIGE abolished. LUIGE abolished. THR ELEV. MINIMA. OCH. ALT(3.0°APCH Path).

NM to IKJ	FAF	6	5	4	3	2	1	MAPt
ALT(3.0° APCH Path)	2000	1918	1599	1281	962	644	325	-

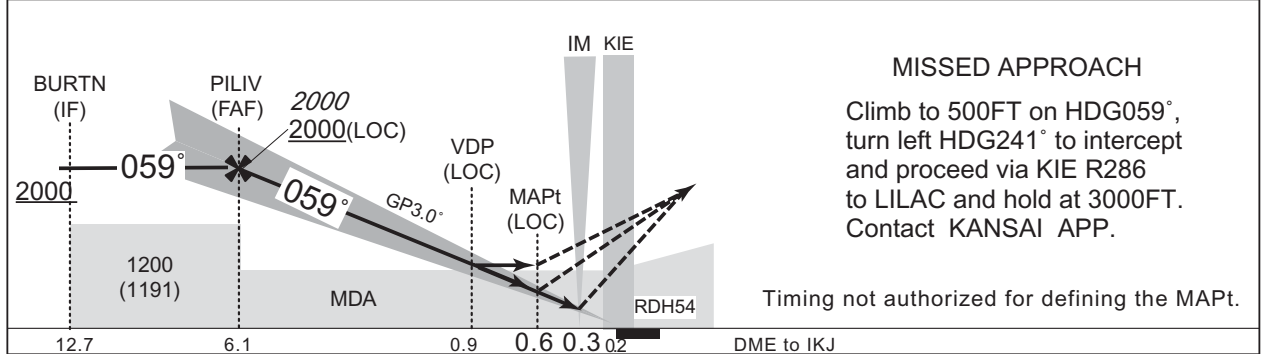

12.7	6.1	0.9	0.6	0.3	0.2	DME to IKJ
12.5	6.0	0.7	0.5	0.1	0	NM to THR

MINIMA			THR elev. 9		AD elev. 17				
CAT	CAT II			CAT I		LOC		CIRCLING	
	DA(H)	RA	RVR	DA(H)	RVR/CMV	MDA(H)	RVR/CMV	MDA(H)	VIS
A									1600
B	109	100	300	209	550	290	800	610	2400
C	(100)			(200)		(281)		(593)	
D/DL							1200		3200

Circling to NORTH side of RWY only.

INSTRUMENT APPROACH CHART

RJBB / KANSAI INTL

ILS Y or LOC Y RWY06L (CAT II)

KANSAI APP 120.25 - 125.5 258.3	ILS - LOC 108.7 IKJ ILS-GP 330.5 ILS-DME CH-24X	KANSAI TOWER 118.2 - 118.05 126.2 - 236.8	RADAR AVBL ATIS 127.85
---------------------------------------	--	---	---------------------------

CHANGE : BOLAL established. JENNY abolished. PROC ALT at SDF. THR ELEV. MINIMA. OCH. ALT(3.0° APCH Path).

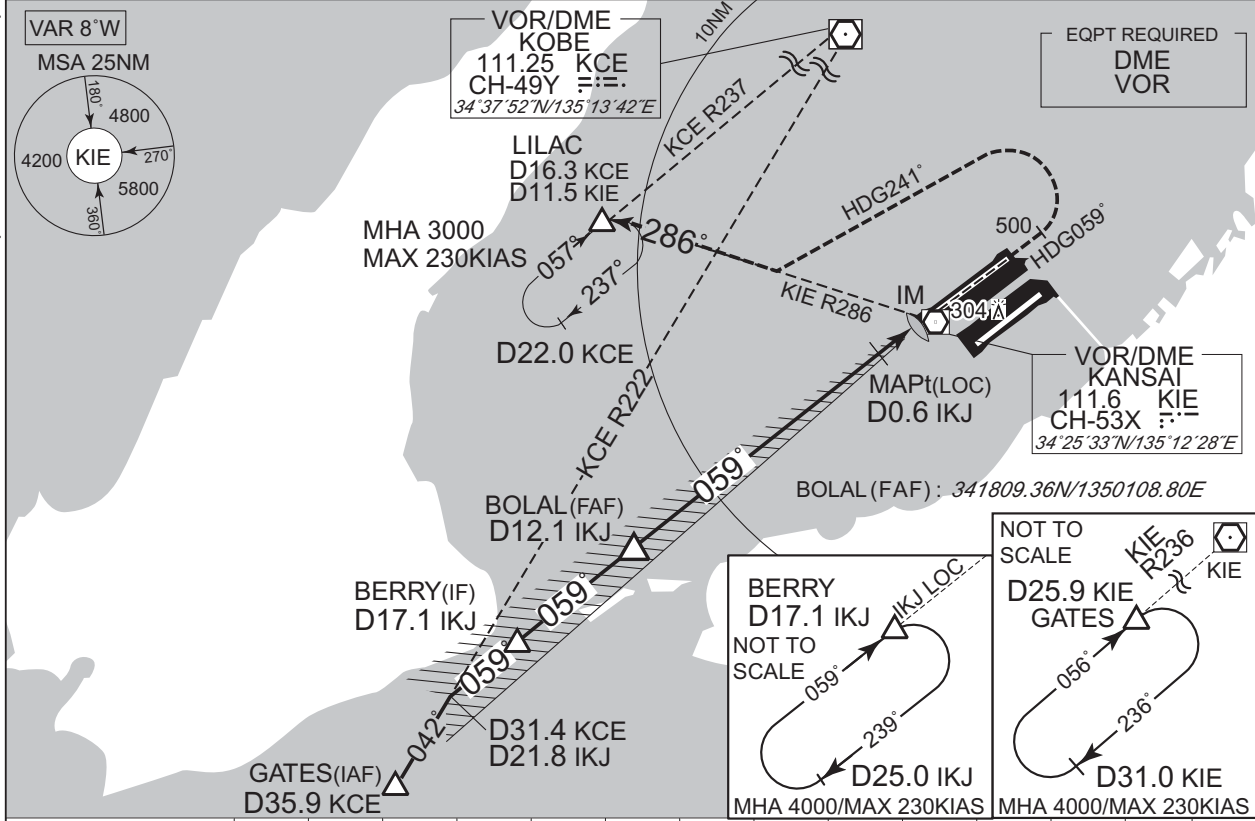

NM to IKJ	FAF	12	11	10	9	8	7	6	5	4	3	2	1	MAPt
ALT(3.0° APCH Path)	4000	3829	3510	3192	2873	2555	2236	1918	1599	1281	962	644	325	-

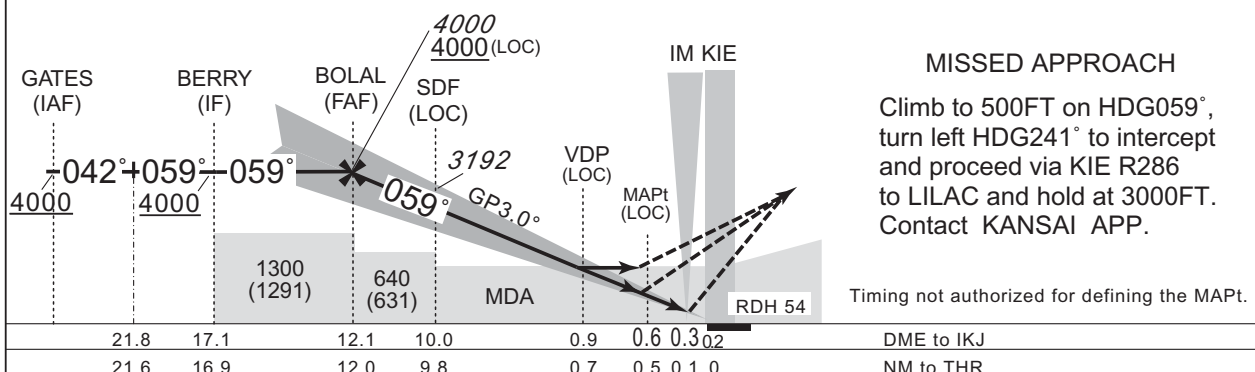

MISSED APPROACH
Climb to 500FT on HDG059°, turn left HDG241° to intercept and proceed via KIE R286 to LILAC and hold at 3000FT. Contact KANSAI APP.

Timing not authorized for defining the MAPt.

21.8	17.1	12.1	10.0	0.9	0.6	0.3	0.2	DME to IKJ						
21.6	16.9	12.0	9.8	0.7	0.5	0.1	0	NM to THR						

MINIMA			THR elev. 9			AD elev. 17			
CAT	CAT II			CAT I		LOC		CIRCLING	
	DA(H)	RA	RVR	DA(H)	RVR/CMV	MDA(H)	RVR/CMV	MDA(H)	VIS
A									1600
B	109	100	300	209	550	290	800	610	2400
C	(100)			(200)		(281)		(593)	
D/DL							1200		3200

Circling to NORTH side of RWY only.

INSTRUMENT APPROACH CHART

RJBB / KANSAI INTL

ILS Z or LOC Z RWY06R (CAT II)

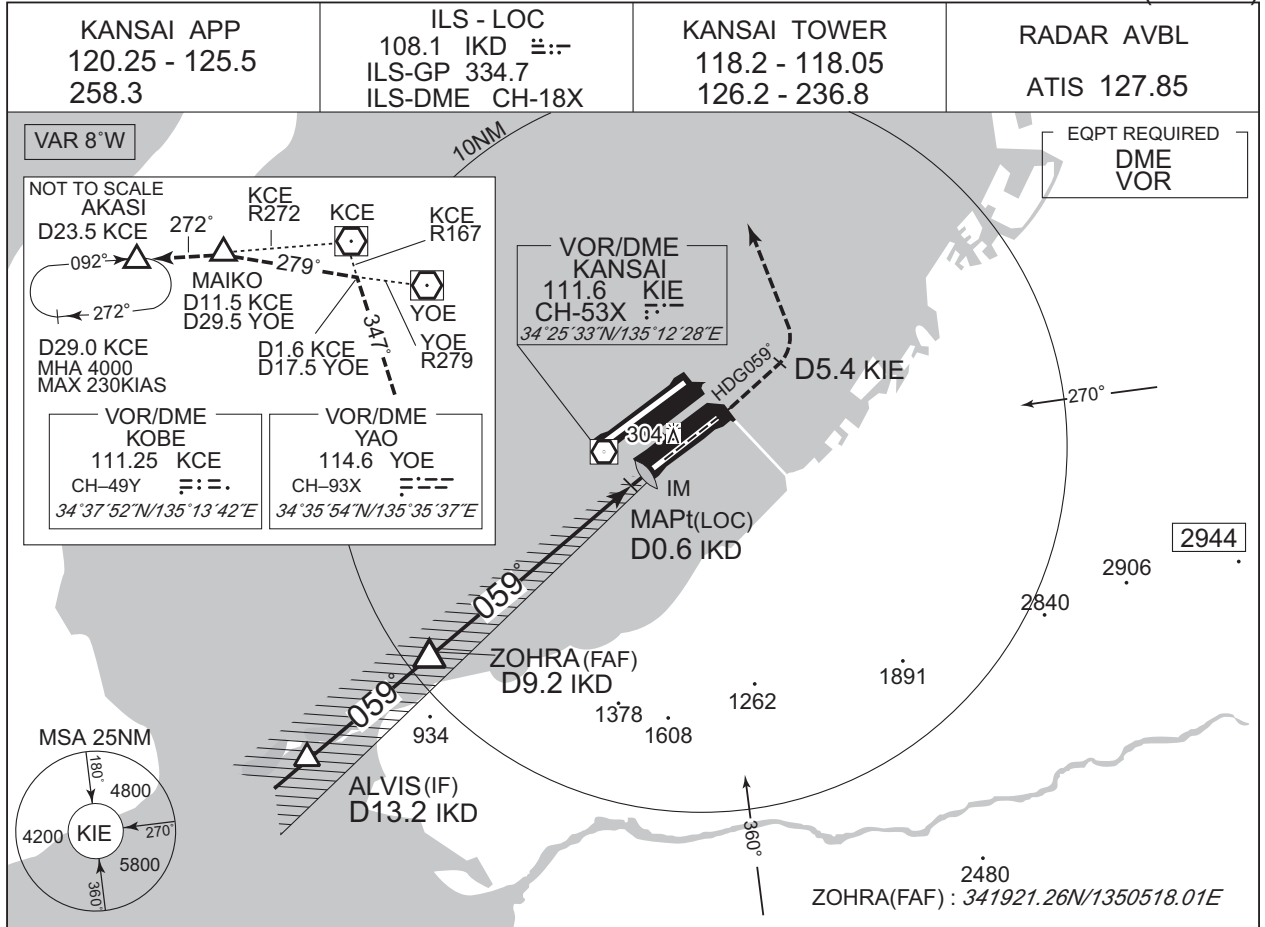

NM to IKD	FAF	9	8	7	6	5	4	3	2	MAPt
ALT(3.0° APCH Path)	3000	2865	2546	2228	1909	1591	1273	954	635	-

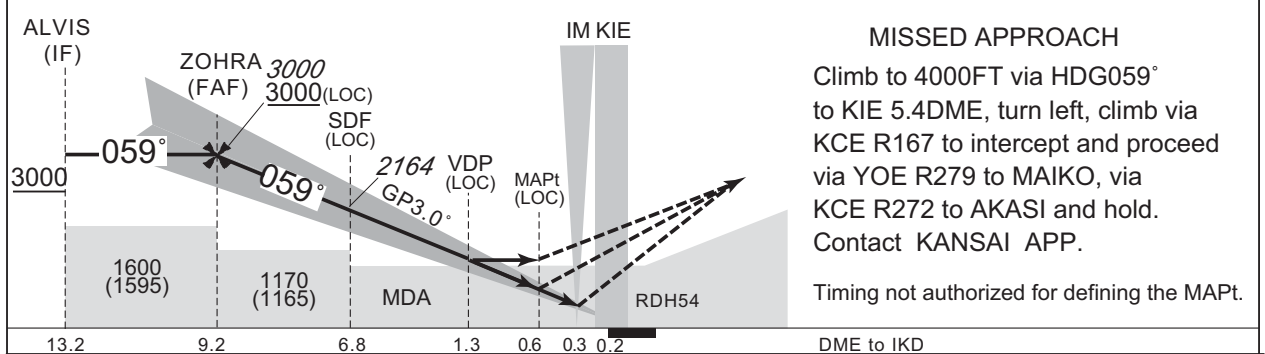

MISSED APPROACH
Climb to 4000FT via HDG059° to KIE 5.4DME, turn left, climb via KCE R167 to intercept and proceed via YO E R279 to MAIKO, via KCE R272 to AKASI and hold. Contact KANSAI APP.
Timing not authorized for defining the MAPt.

13.2	9.2	6.8	1.3	0.6	0.3	0.2	DME to IKD
13.0	9.0	6.6	1.1	0.5	0.1	0	NM to THR

MINIMA		THR elev. 5			AD elev. 17				
CAT	CAT II			CAT I		LOC		CIRCLING	
	DA(H)	RA	RVR	DA(H)	RVR/CMV	MDA(H)	RVR/CMV	MDA(H)	VIS
A	105 (100)	100	300	205 (200)	550	390 (385)	900	610 (593)	1600
B							1000		
C							1400		
D/DL									3200

CHANGE : Description of VAR.

Circling to NORTH side of RWY only.

INSTRUMENT APPROACH CHART

RJBB / KANSAI INTL

ILS Y or LOC Y RWY06R (CAT II)

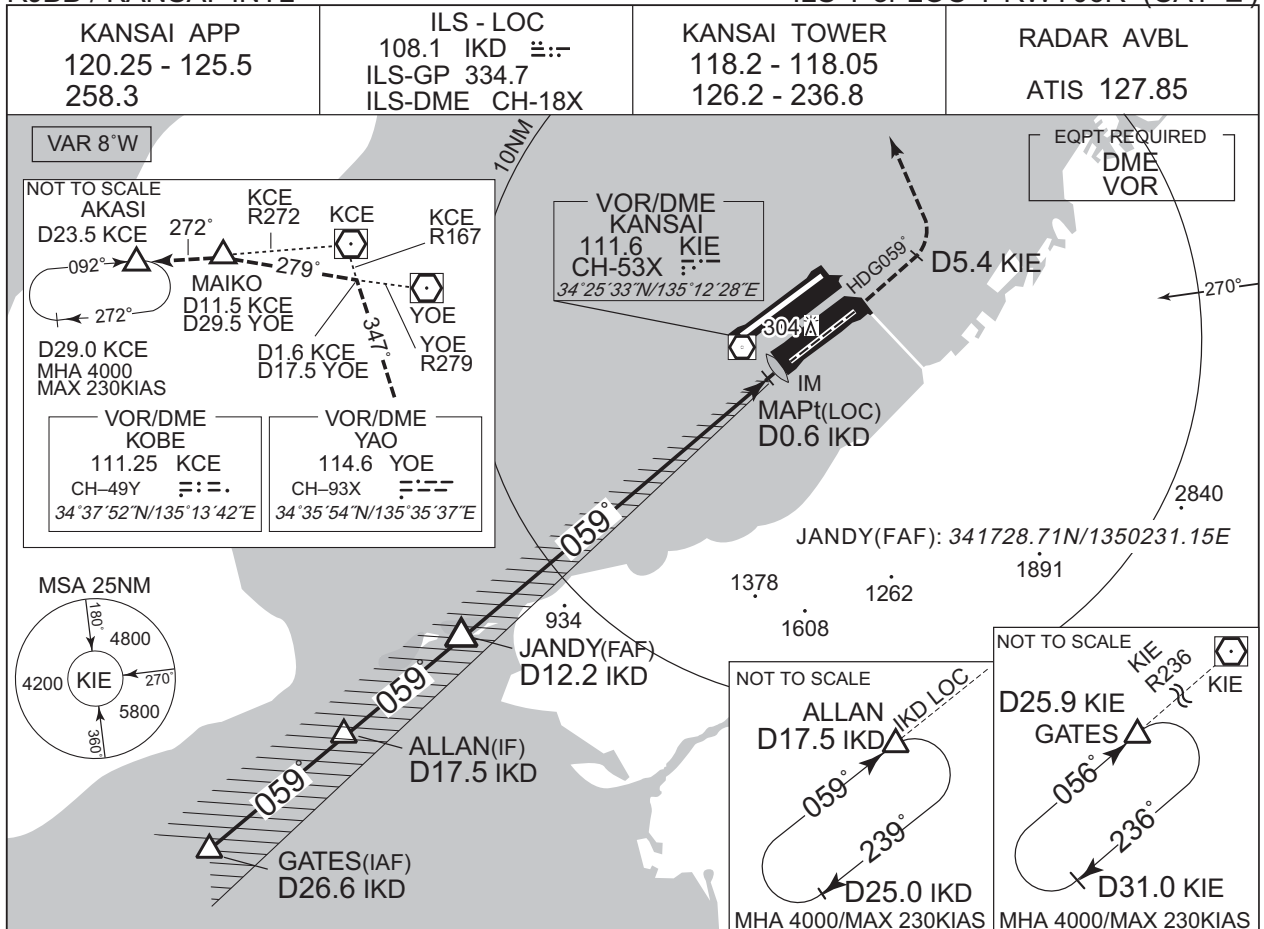

NM to IKD	FAF	12	11	10	9	8	7	6	5	4	3	2	MAPt
ALT(3.0° APCH Path)	4000	3820	3502	3183	2865	2546	2228	1909	1591	1273	954	635	-

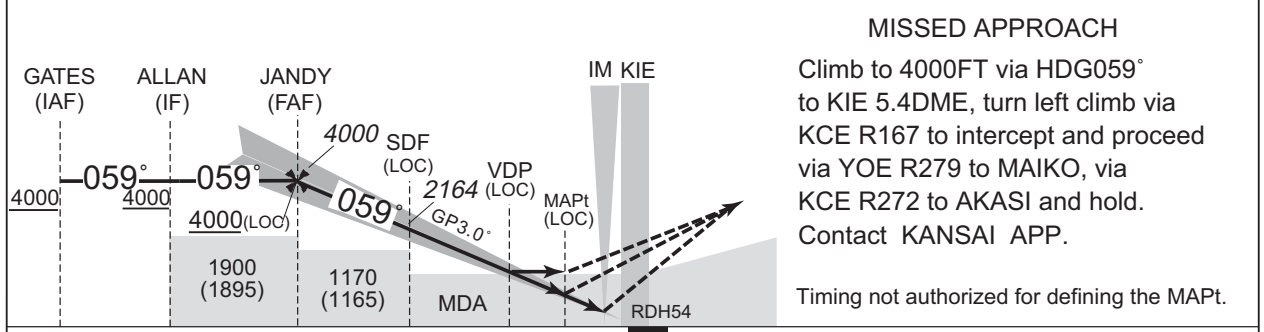

26.6	17.5	12.2	6.8	1.3	0.6	0.3	0.2	DME to IKD					
26.4	17.4	12.0	6.6	1.1	0.5	0.1	0	NM to THR					

MINIMA THR elev. 5 AD elev. 17

CAT	CAT II			CAT I		LOC		CIRCLING	
	DA(H)	RA	RVR	DA(H)	RVR/CMV	MDA(H)	RVR/CMV	MDA(H)	VIS
A	105 (100)	100	300	205 (200)	550	390 (385)	1000	610 (593)	1600
B									2400
C									3200
D/DL							1400		3200

Circling to NORTH side of RWY only.

CHANGE : Description of VAR.

INSTRUMENT APPROACH CHART

RJBB / KANSAI INTL ILS Z or LOC Z RWY24L (CAT II)

KANSAI APP 120.25 - 125.5 258.3	ILS - LOC 110.7 IKN Ǝ:- ILS-GP 330.2 ILS-DME CH-44X	KANSAI TOWER 118.2 - 118.05 126.2 - 236.8	RADAR AVBL ATIS 127.85
---------------------------------------	--	---	---------------------------

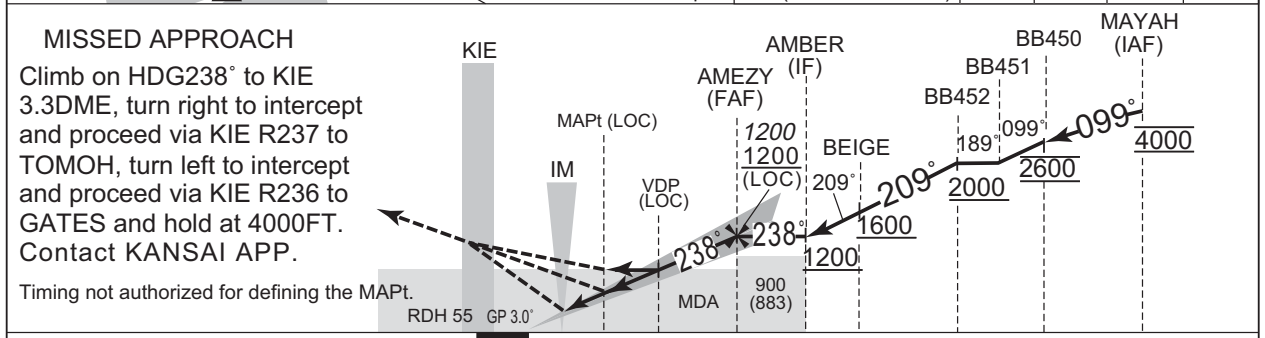
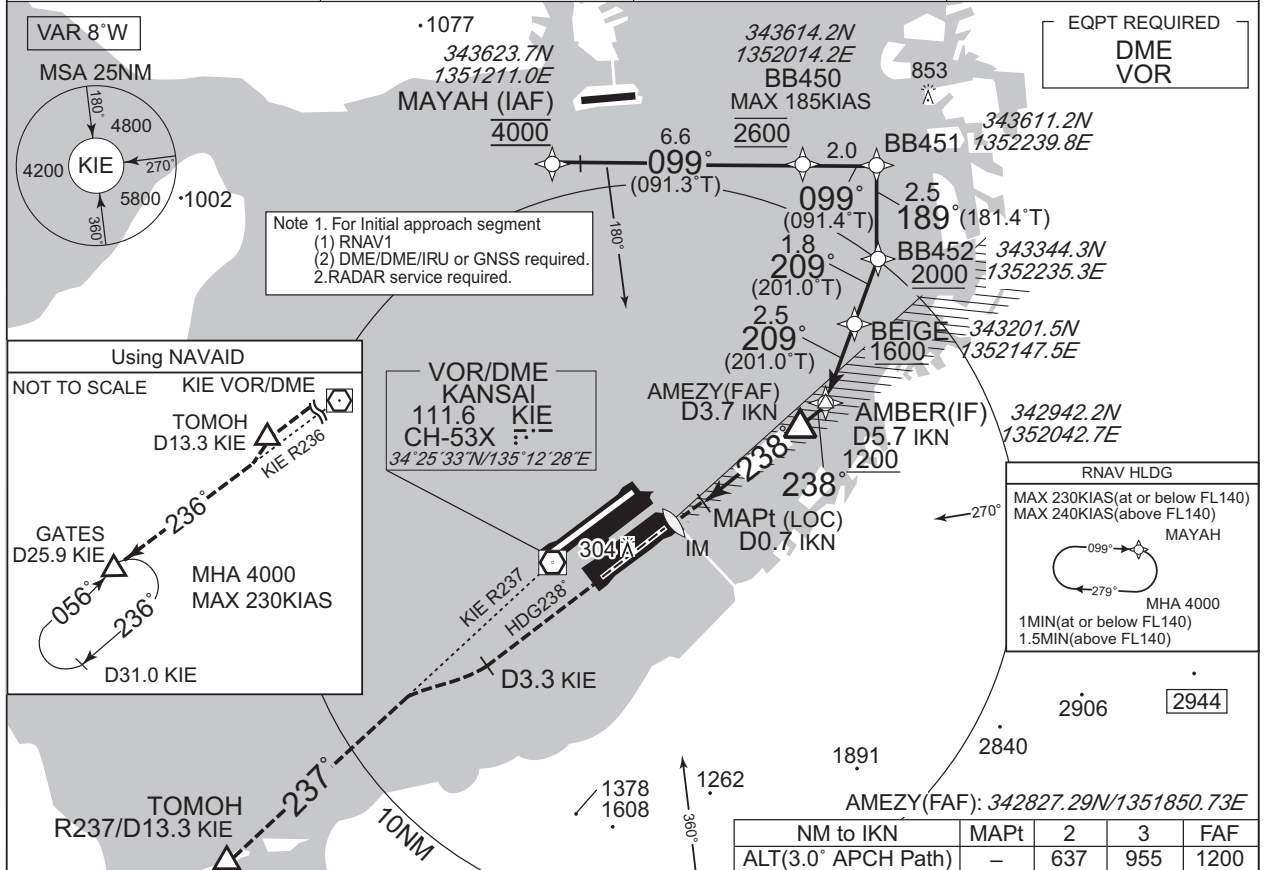

DME to IKN	0.2	0.3	0.7	1.3	3.7	5.7
NM to THR	0	0.1	0.5	1.1	3.5	5.5

MINIMA THR elev. 12 AD elev. 17

CAT	CAT II			CAT I		LOC		CIRCLING	
	DA(H)	RA	RVR	DA(H)	RVR/CMV	MDA(H)	RVR/CMV	MDA(H)	VIS
A	112 (100)	100	300	212 (200)	550	390 (373)	1000	610 (593)	1600
B									2400
C									3200
D/DL							1400		

Circling to NORTH side of RWY only.

CHANGE : Description of VAR.

INSTRUMENT APPROACH CHART

RJBB / KANSAI INTL ILS Y or LOC Y RWY24L (CAT II)

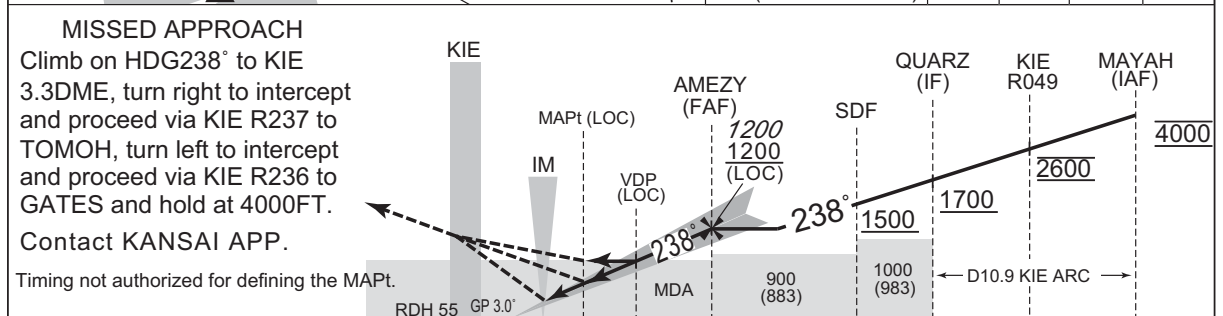
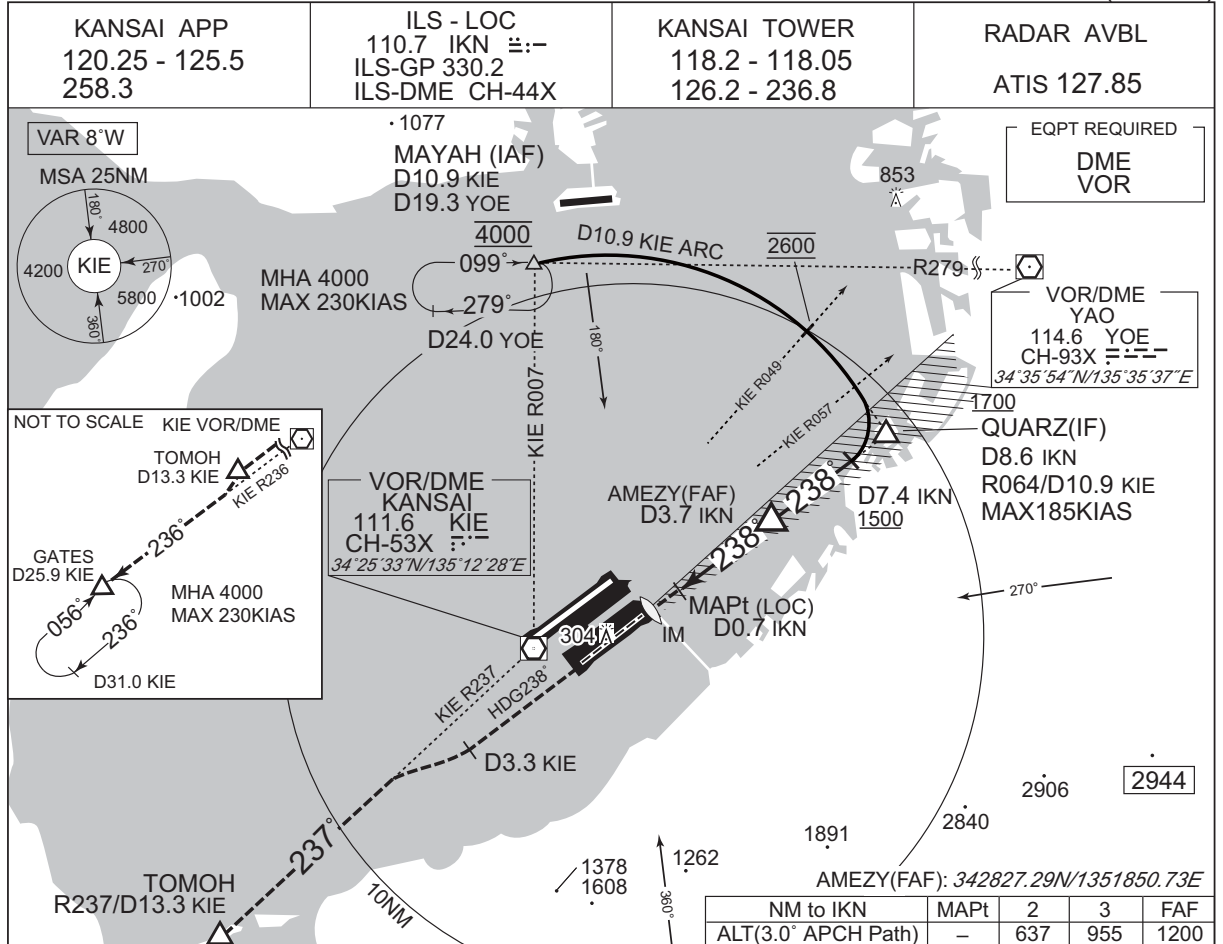

DME to IKN	0.2	0.3	0.7	1.3	3.7	7.4	8.6
NM to THR	0	0.1	0.5	1.1	3.5	7.2	8.4

MINIMA		THR elev. 12			AD elev. 17				
CAT	CAT II			CAT I		LOC		CIRCLING	
	DA(H)	RA	RVR	DA(H)	RVR/CMV	MDA(H)	RVR/CMV	MDA(H)	VIS
A	112 (100)	100	300	212 (200)	550	390 (373)	1000	610 (593)	1600
B									2400
C									3200
D/DL							1400		

Circling to NORTH side of RWY only.

CHANGE : Description of VAR.

INSTRUMENT APPROACH CHART

RJBB / KANSAI INTL

ILS Z or LOC Z RWY24R (CAT II)

KANSAI APP 120.25 - 125.5 258.3	ILS - LOC 108.5 IKW ILS-GP 329.9 ILS-DME CH-22X	KANSAI TOWER 118.2 - 118.05 126.2 - 236.8	RADAR AVBL ATIS 127.85
---------------------------------------	--	---	-------------------------------

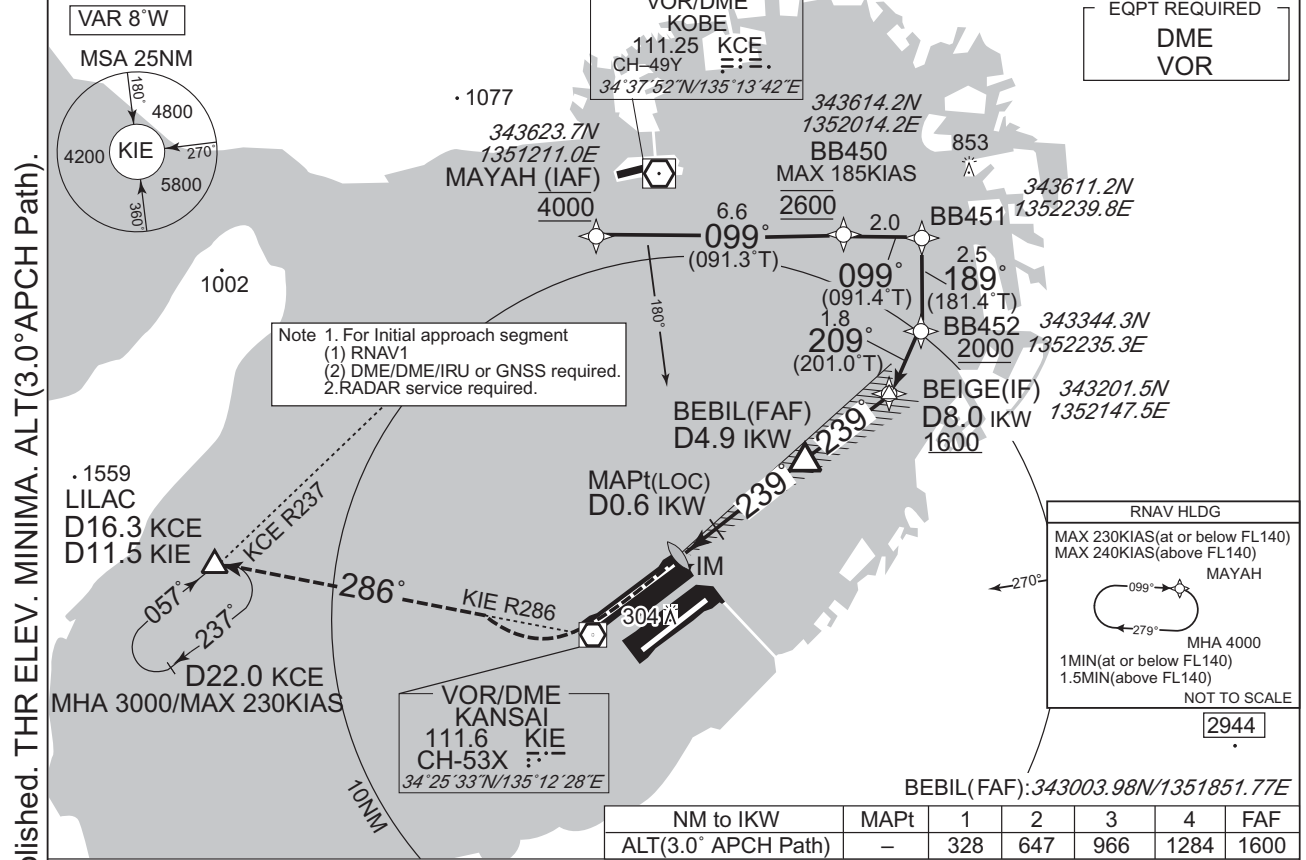

CHANGE : PROC course: BEBIL established. BEBIL abolished. BLOND abolished. THR ELEV. MINIMA. ALT(3.0° APCH Path).

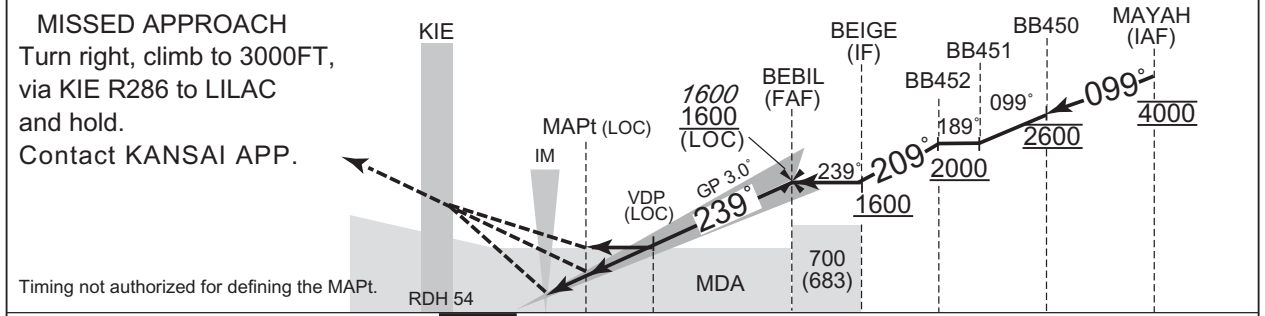

DME to IKW	0.2	0.3	0.6	0.9	4.9	8.0
NM to THR	0	0.1	0.5	0.7	4.7	7.9

MINIMA		THR elev. 16			AD elev. 17				
CAT	CAT II			CAT I		LOC		CIRCLING	
	DA(H)	RA	RVR	DA(H)	RVR/CMV	MDA(H)	RVR/CMV	MDA(H)	VIS
A									1600
B	116	100	300	216	550	300	800	610	2400
C	(100)			(200)		(283)		(593)	
D/DL							1200		3200

Circling to NORTH side of RWY only.

INSTRUMENT APPROACH CHART

RJBB / KANSAI INTL

ILS Y or LOC Y RWY24R (CAT II)

KANSAI APP 120.25 - 125.5 258.3	ILS - LOC 108.5 IKW ILS-GP 329.9 ILS-DME CH-22X	KANSAI TOWER 118.2 - 118.05 126.2 - 236.8	RADAR AVBL ATIS 127.85
---------------------------------------	--	---	-------------------------------

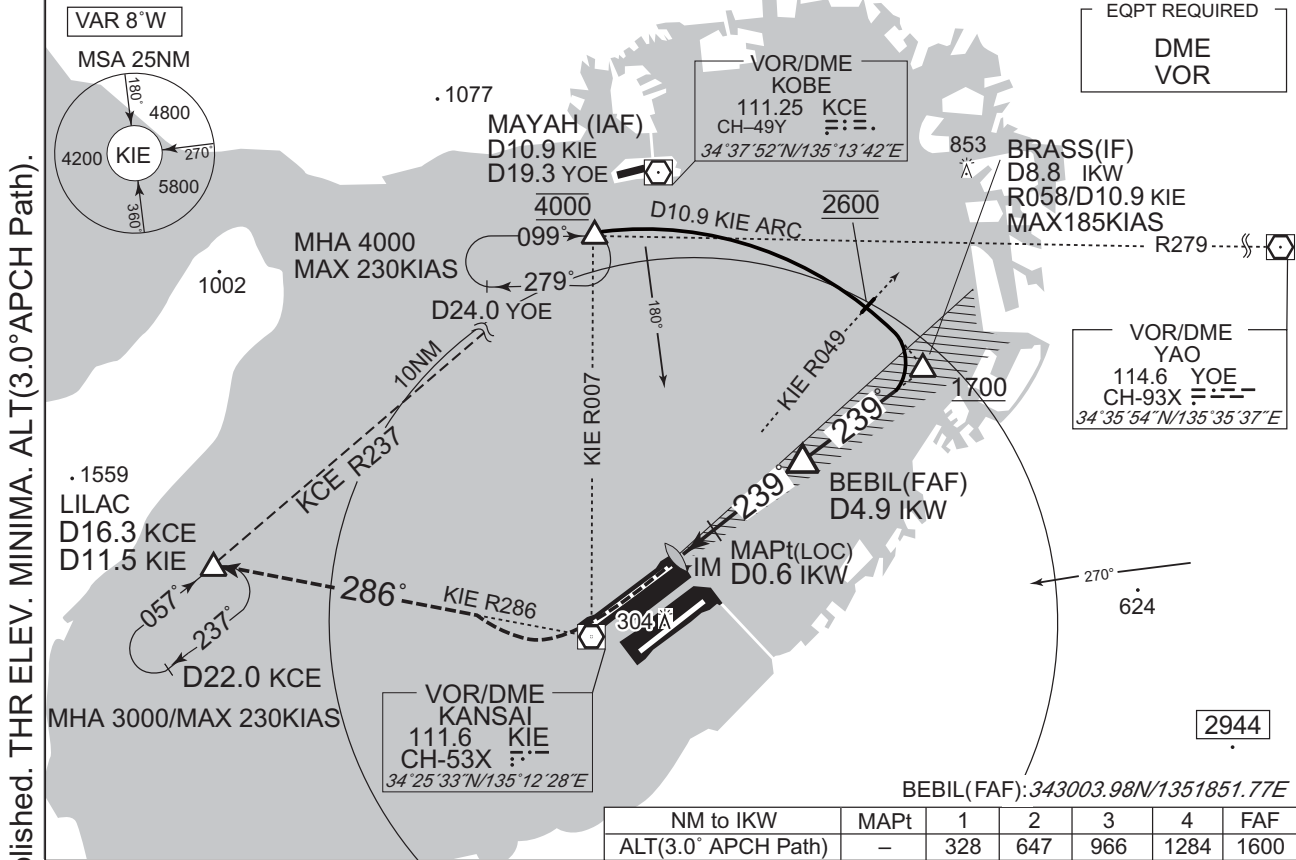

CHANGE : PROC course. BEBIL established. BLOND abolished. THR ELEV. MINIMA. ALT(3.0° APCH Path).

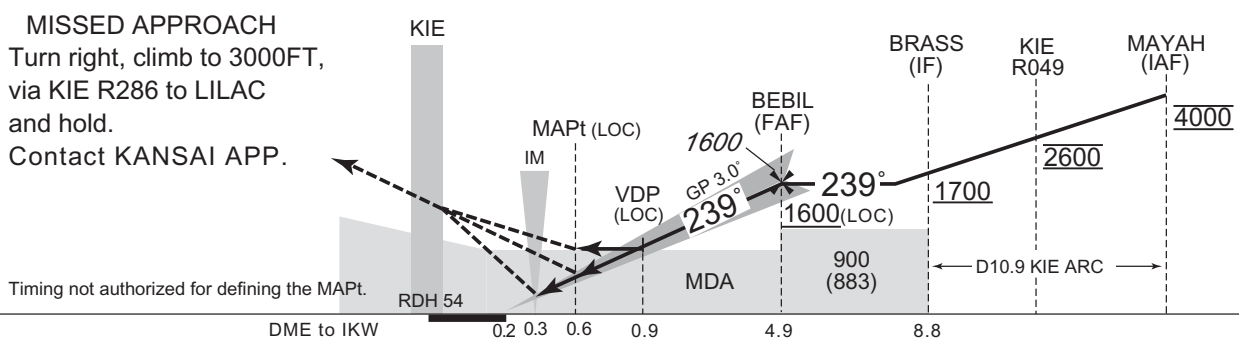

DME to IKW	0.2	0.3	0.6	0.9	4.9	8.8
NM to THR	0	0.1	0.5	0.7	4.7	8.6

MINIMA			THR elev. 16			AD elev. 17			
CAT	CAT II			CAT I		LOC		CIRCLING	
	DA(H)	RA	RVR	DA(H)	RVR/CMV	MDA(H)	RVR/CMV	MDA(H)	VIS
A									1600
B	116	100	300	216	550	300	800	610	2400
C	(100)			(200)		(283)		(593)	
D/DL							1200		3200

Circling to NORTH side of RWY only.

INSTRUMENT APPROACH CHART

RJBB / KANSAI INTL

VOR RWY06L

KANSAI APP 120.25 - 125.5 258.3	KANSAI VOR/DME 111.6 KIE CH-53X 34°25'33"N/135°12'28"E	KANSAI TOWER 118.2 - 118.05 126.2 - 236.8	RADAR AVBL ATIS 127.85
--	--	--	----------------------------------

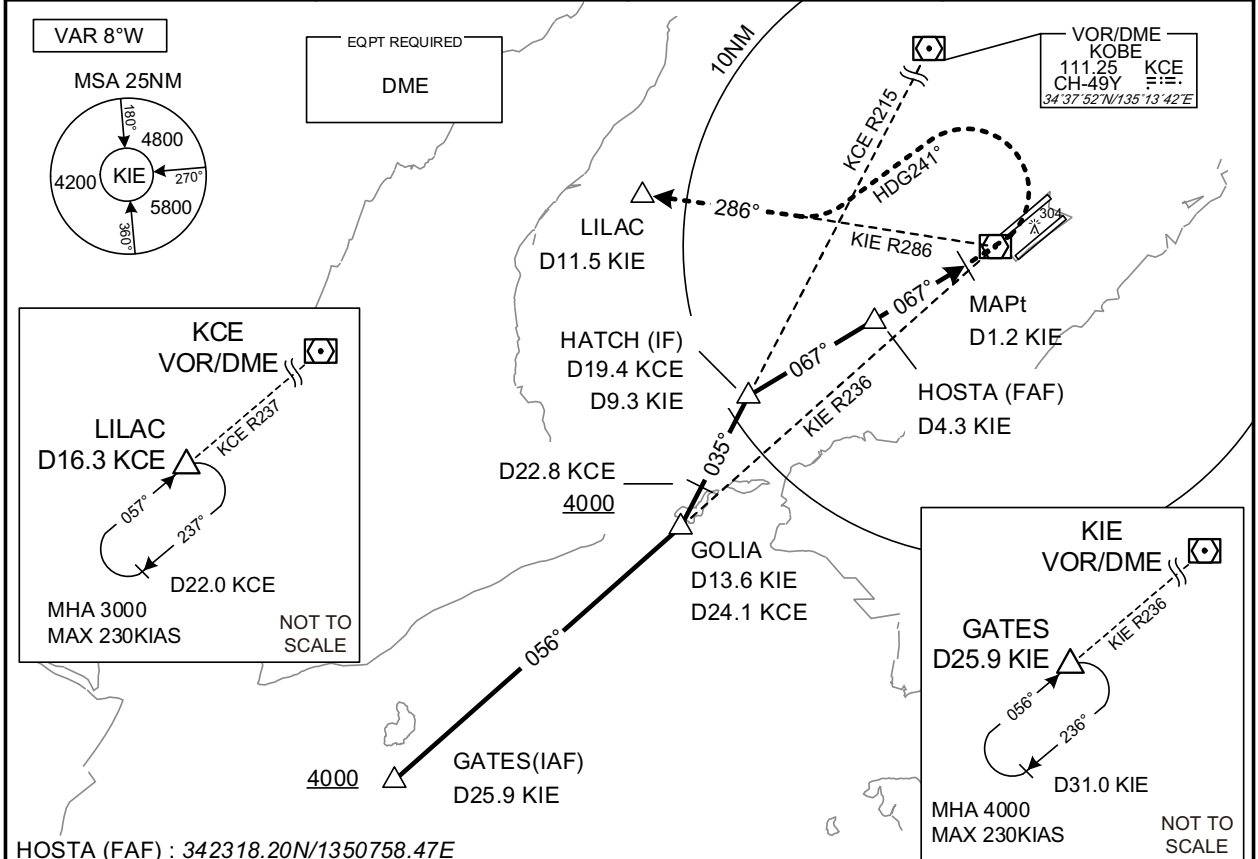

NM to KIE	FAF	4	3	2	MAPt
ALT(3.0° APCH Path)	1450	1343	1025	707	-

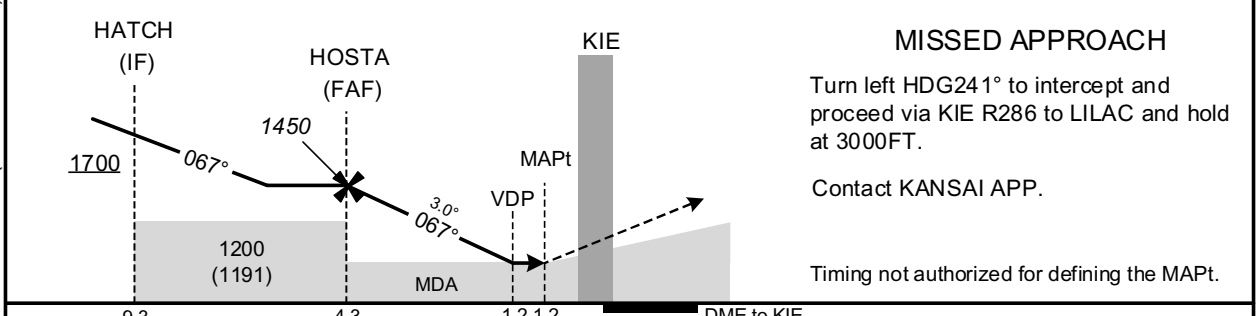

9.3	4.3	1.2	1.2	DME to KIE
9.4	4.4	1.3	1.2	NM to THR

MINIMA		THR elev. 9		AD elev. 17		
CAT	MDA(H)		RVR/CMV		CIRCLING	
	450 (441)		900		MDA(H) VIS	
A			1000		610 (593) 1600	
B			1400		2400	
C					3200	
D						

Circling to NORTH side of RWY only.

CHANGE: THR ELEV. MINIMA. PROC ALT. OCH. ALT(3.0° APCH Path).

INSTRUMENT APPROACH CHART

RJBB / KANSAI INTL

VOR RWY24R

KANSAI APP 120.25 - 125.5 258.3	KANSAI VOR/DME 111.6 KIE CH-53X 34°25'33"N/135°12'28"E	KANSAI TOWER 118.2 - 118.05 126.2 - 236.8	RADAR AVBL ATIS 127.85
--	--	--	----------------------------------

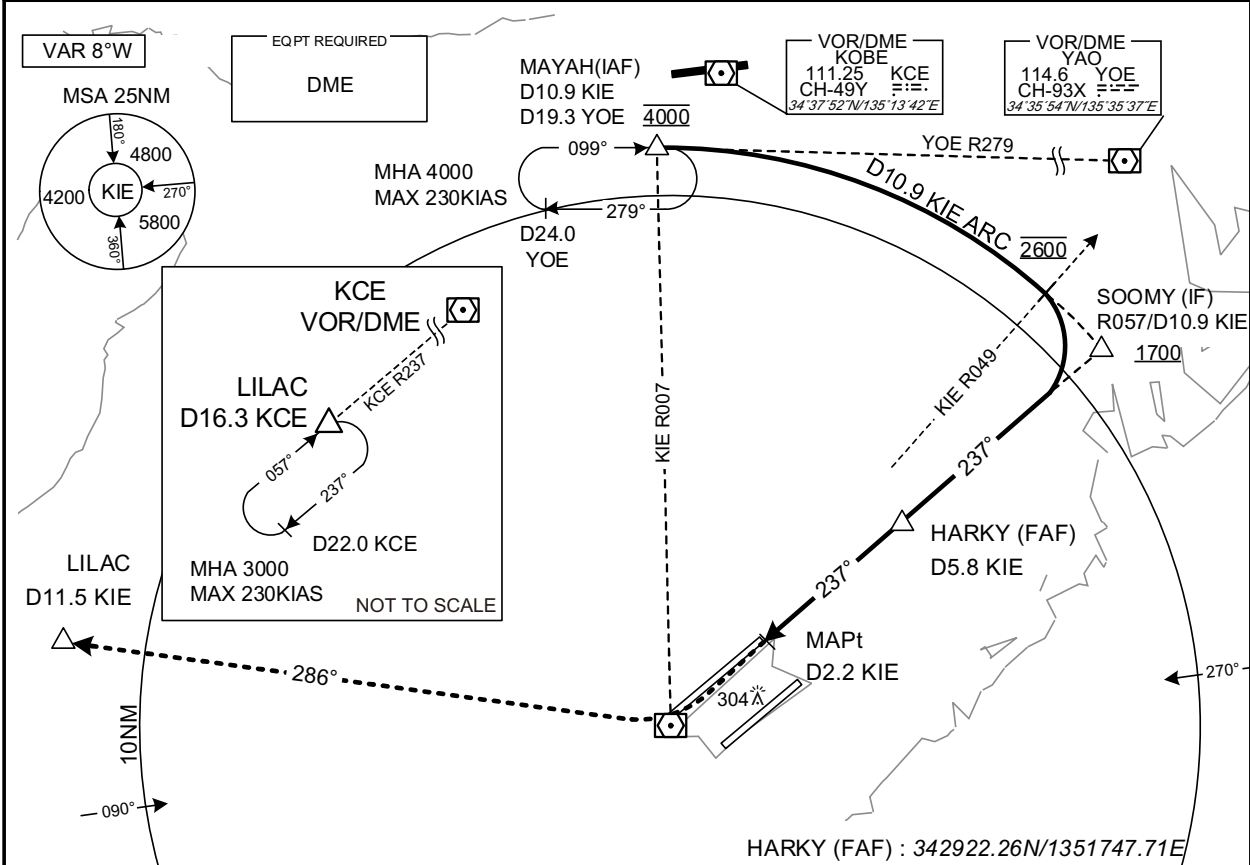

	NM to KIE	MAPt	4	5	FAF
	ALT(3.0° APCH Path)	-	635	953	1218

MISSED APPROACH

Turn right, climb to 3000FT, via KIE R286 to LILAC and hold .
Contact KANSAI APP.

Timing not authorized for defining the MAPt.

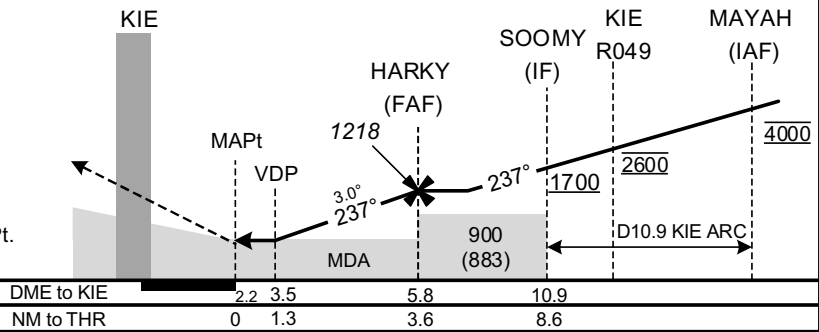

DME to KIE	2.2	3.5	5.8	10.9
NM to THR	0	1.3	3.6	8.6

MINIMA		THR elev. 16		AD elev. 17	
CAT			CIRCLING		
	MDA(H)	RVR/CMV	MDA(H)	VIS	
A	470 (453)	1000	610 (593)	1600	
B		1200		2400	
C		1600		3200	

Circling to NORTH side of RWY only.

CHANGE : THR ELEV. PROC ALT. ALT(3.0°APCH Path).

INSTRUMENT APPROACH CHART

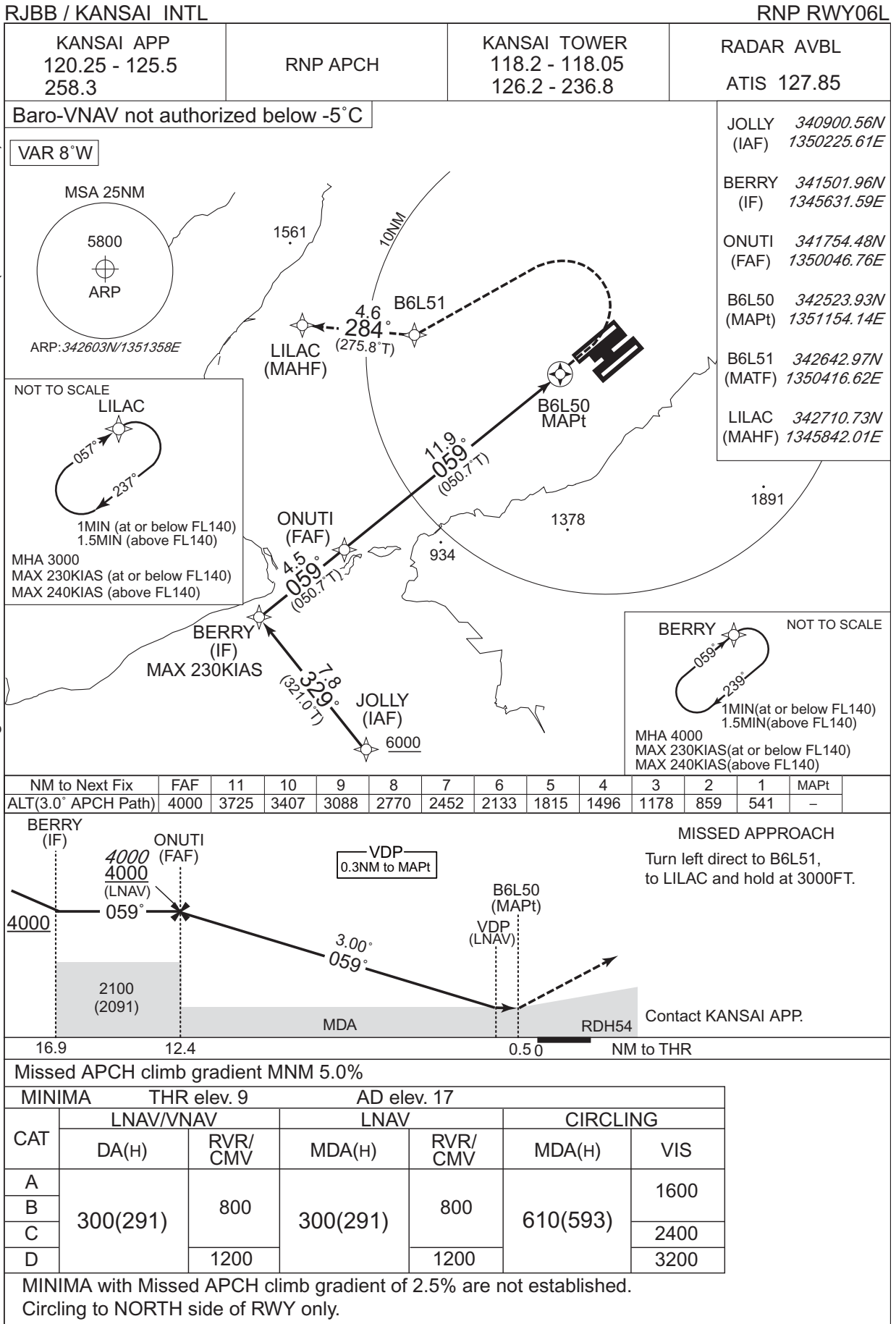

CHANGE : ONUTI established. KADAR abolished. Missed APCH for using VOR/DME abolished. THR ELEV. MINIMA. OCH. ALT(3.0° APCH Path).

INSTRUMENT APPROACH CHART

RJBB / KANSAI INTL

RNP RWY06R

KANSAI APP 120.25 - 125.5 258.3	RNP APCH	KANSAI TOWER 118.2 - 118.05 126.2 - 236.8	RADAR AVBL ATIS 127.85
---------------------------------------	----------	---	---------------------------

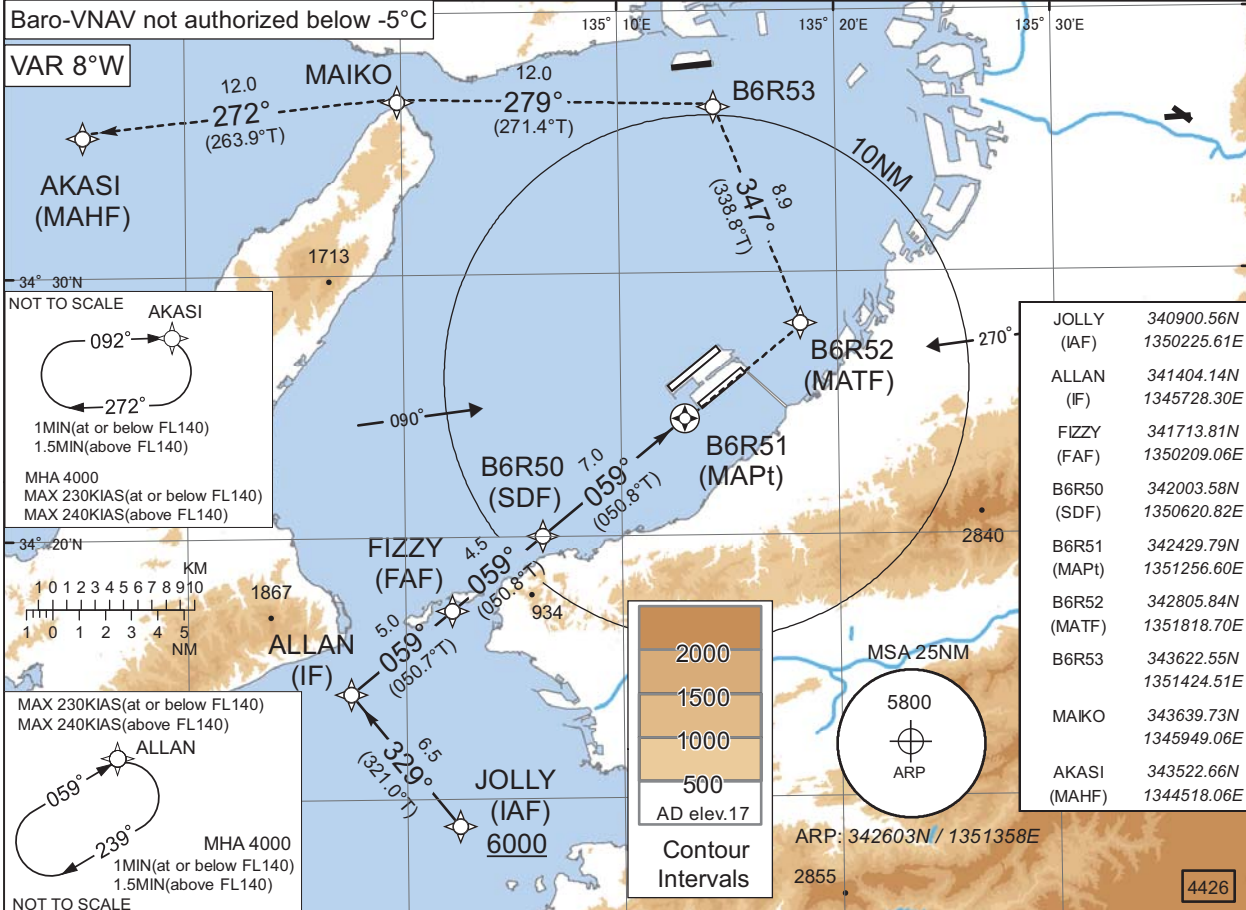

JOLLY (IAF)	340900.56N 1350225.61E
ALLAN (IF)	341404.14N 1345728.30E
FIZZY (FAF)	341713.81N 1350209.06E
B6R50 (SDF)	342003.58N 1350620.82E
B6R51 (MAPt)	342429.79N 1351256.60E
B6R52 (MATF)	342805.84N 1351818.70E
B6R53	343622.55N 1351424.51E
MAIKO	343639.73N 1345949.06E
AKASI (MAHF)	343522.66N 1344518.06E

NM to Next Fix	FAF	11	10	9	8	7	6	5	4	3	2	1	MAPt
ALT (3.0° APCH Path)	4000	3838	3519	3201	2882	2564	2245	1927	1609	1290	972	653	-

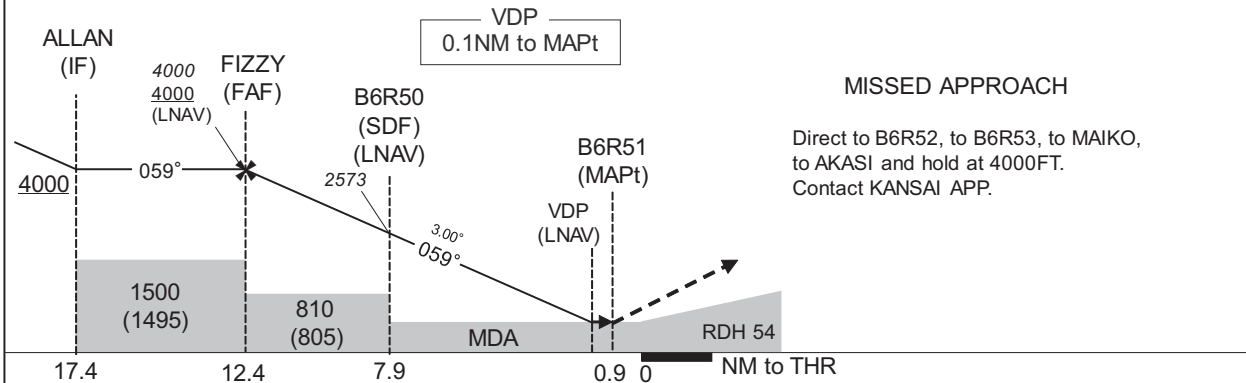

MISSED APPROACH
Direct to B6R52, to B6R53, to MAIKO, to AKASI and hold at 4000FT. Contact KANSAI APP.

Missed APCH climb gradient MNM 3.0%

MINIMA		THR elev. 5	AD elev. 17				
CAT	LNAV/VNAV		LNAV		CIRCLING		
	DA(H)	RVR/CMV	MDA(H)	RVR/CMV	MDA(H)	VIS	
A	340(335)	900	340(335)	900	610(593)	1600	
B		1000		1000		2400	
C		1400		1400		1400	3200
D							

MINIMA with Missed APCH climb gradient of 2.5% are not established.
Circling to NORTH side of RWY only.

CHANGE : Missed APCH for using VOR/DME abolished.

INSTRUMENT APPROACH CHART

RJBB / KANSAI INTL RNP RWY24L

KANSAI APP 120.25 - 125.5 258.3	RNP APCH	KANSAI TOWER 118.2 - 118.05 126.2 - 236.8	RADAR AVBL ATIS 127.85
---------------------------------------	----------	---	---------------------------

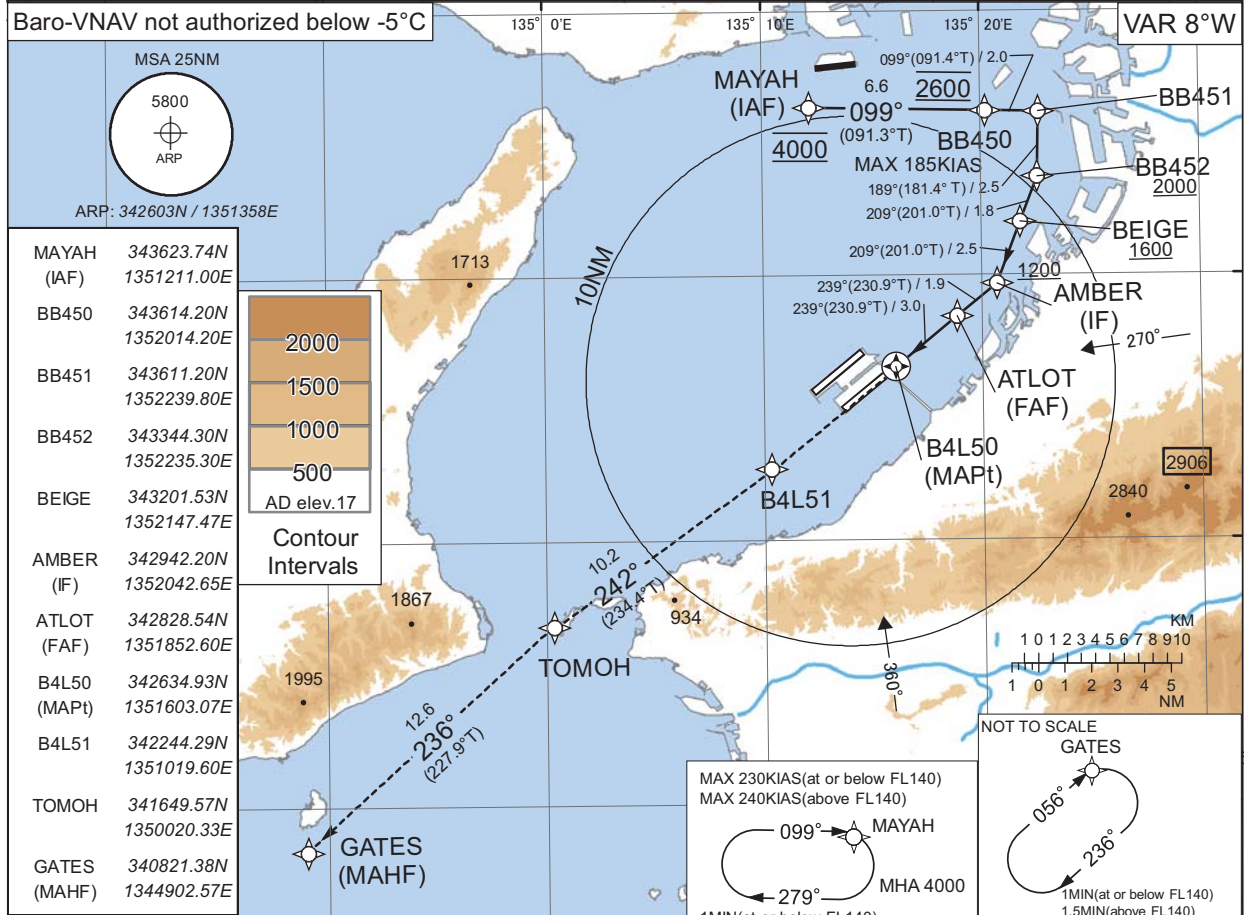

NM to Next Fix	MAPt	1	2	FAF
ALT (3.0° APCH Path)	-	561	880	1200

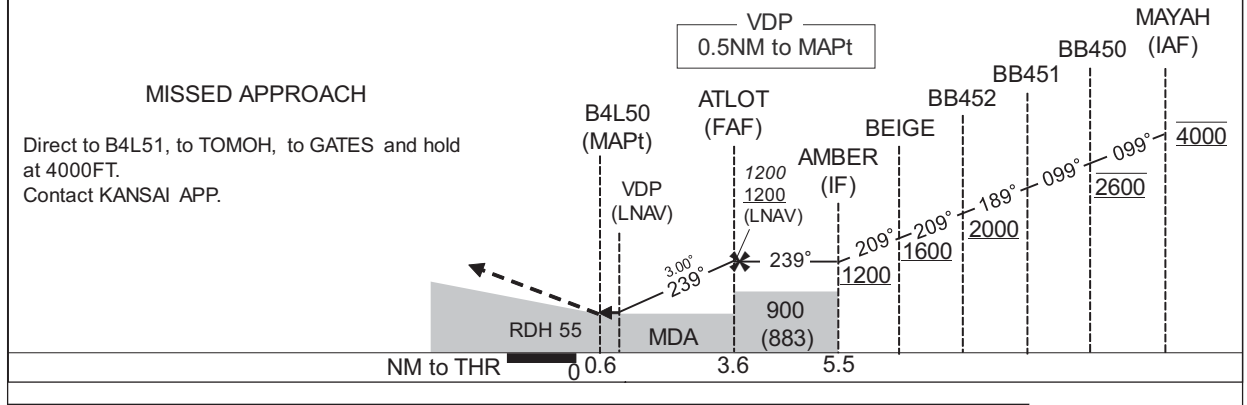

MINIMA	THR elev. 12		AD elev. 17			
	LNAV/VNAV		LNAV		CIRCLING	
CAT	DA(H)	RVR/CMV	MDA(H)	RVR/CMV	MDA(H)	VIS
A	400(388)	900	400(383)	900	610(593)	1600
B		1000		1000		2400
C		1400		1400		3200
D						

Circling to NORTH side of RWY only.

CHANGE : Missed APCH for using VOR/DME abolished.

INSTRUMENT APPROACH CHART

RJBB / KANSAI INTL

RNP RWY24R

KANSAI APP 120.25 - 125.5 258.3	RNP APCH	KANSAI TOWER 118.2 - 118.05 126.2 - 236.8	RADAR AVBL ATIS 127.85
---------------------------------------	----------	---	---------------------------

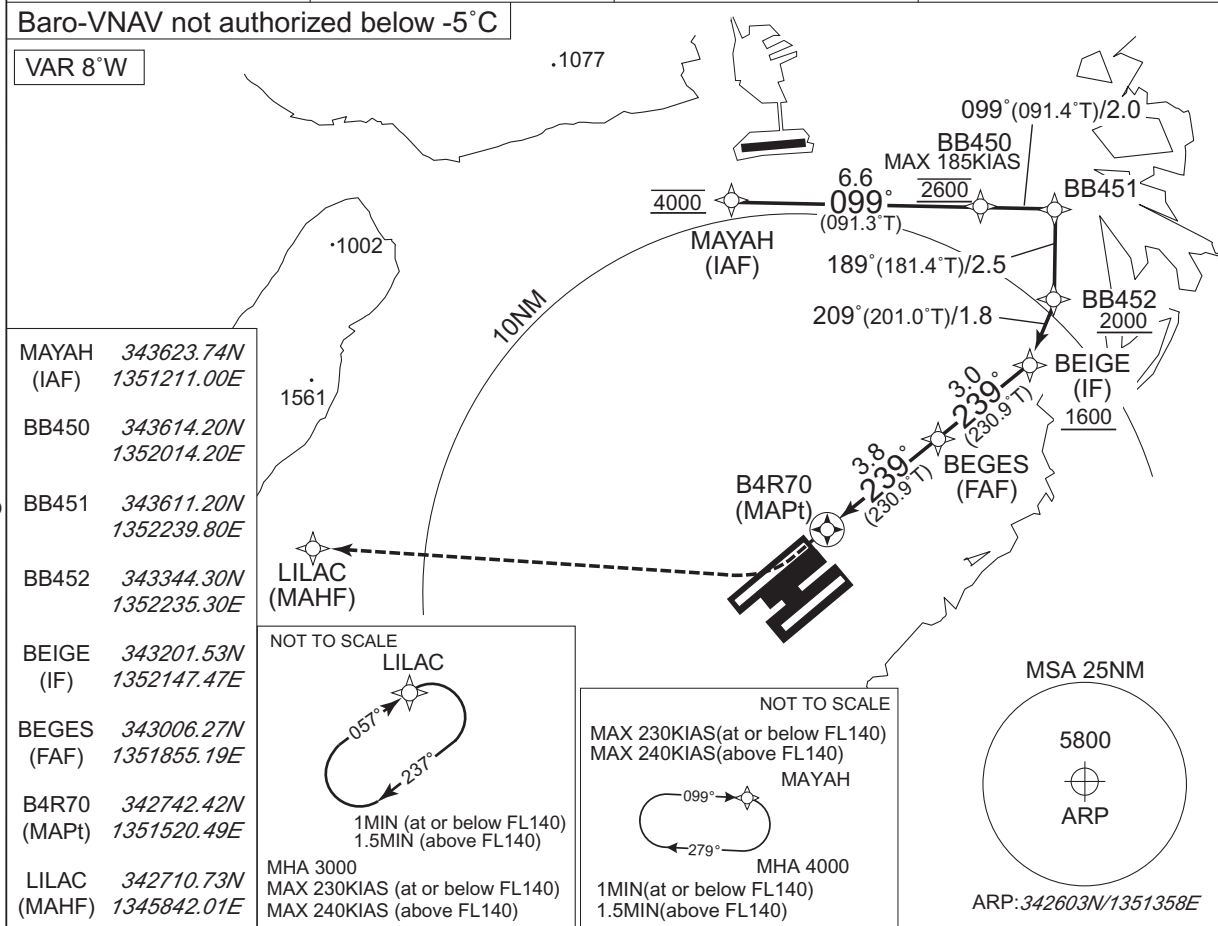

NM to Next Fix	MAPt	1	2	3	FAF
ALT(3.0° APCH Path)	-	707	1025	1343	1600

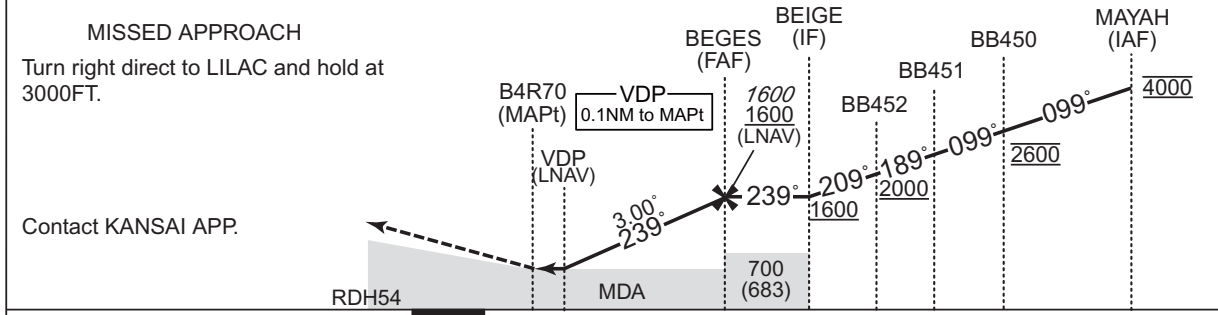

Missed APCH climb gradient MNM 5.0%

MINIMA		THR elev. 16		AD elev. 17		
CAT	LNAV/VNAV		LNAV		CIRCLING	
	DA(H)	RVR/CMV	MDA(H)	RVR/CMV	MDA(H)	VIS
A	410(394)	900	400(383)	900	610(593)	1600
B		1000		1400		2400
C		1400		3200		
D						

MINIMA with Missed APCH climb gradient of 2.5% are not established.
Circling to NORTH side of RWY only.

CHANGE : BEGES established. MAJ OH abolished. TH R ELEV. Missed APCH for using VOR/DME abolished. MINIMA.

RJBB / KANSAI INTL

HLDG PATTERN

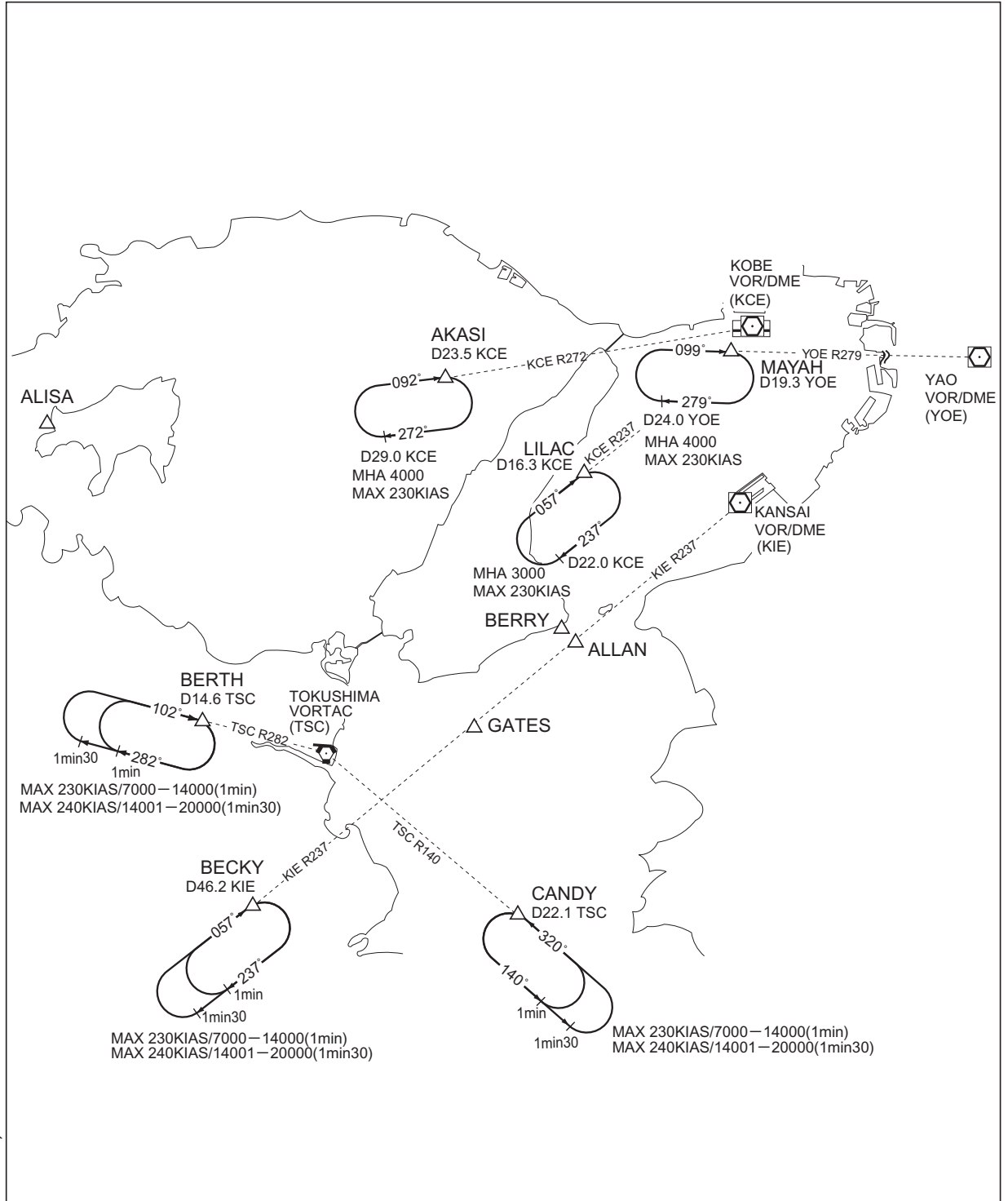

CHANGE : HLDG course(ALLAN).

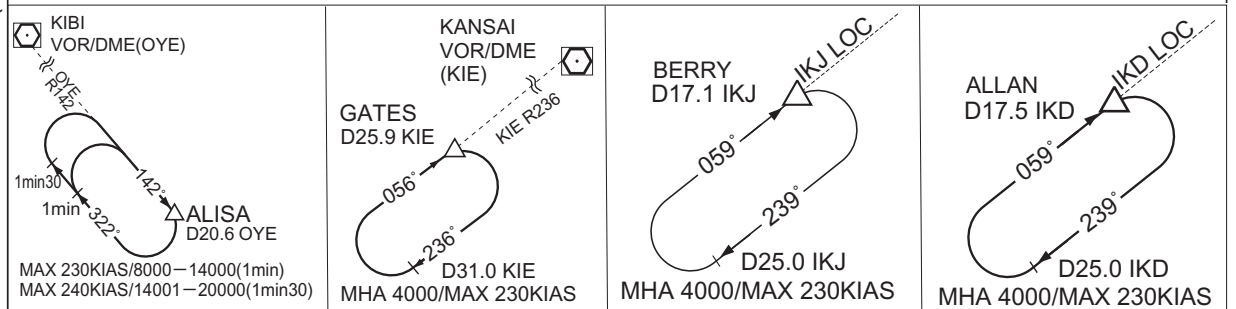

RJBB / KANSAI INTL

RNAV HLDG PATTERN

Note 1)DME/DME/IRU or GNSS required.
2)RADAR service required.

RNAV1

1)Outbound Time / Distance
2)Speed
→See Tabular Description.

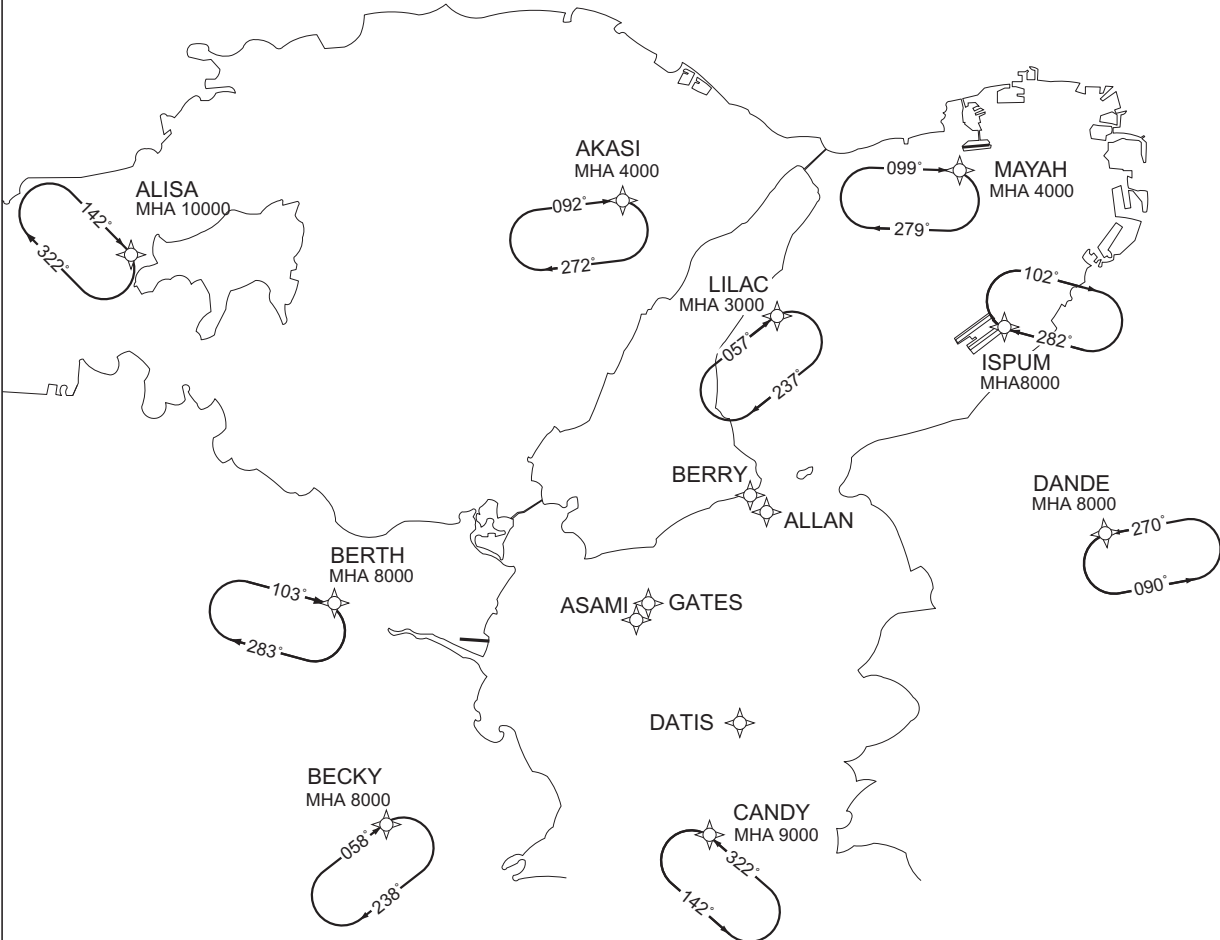

CHANGE : MHA at AKASI.

<p>ASAMI MHA 4000</p>	<p>BERRY MHA 4000</p>	<p>ALLAN MHA 4000</p>	<p>DATIS MHA 6000</p>	<p>GATES MHA 4000</p>
---------------------------	---------------------------	---------------------------	---------------------------	---------------------------

RJBB / KANSAI INTL

RNAV HLDG PATTERN

Path	Waypoint Identifier	Inbound Course °M(^T)	Magnetic Variation	Outbound Time (MIN)	Outbound Distance (NM)	Turn Direction	Minimum Altitude (FT)	Maximum Altitude (FT)	Speed (KIAS)	Navigation Specification
Hold	AKASI	092 (083.8)	-8.0	1.0(-14000) 1.5(+14001)	—	R	4000	—	-230(-14000) -240(+14001)	RNAV1
Hold	ALISA	142 (134.0)	-8.0	1.0(-14000) 1.5(+14001)	—	R	10000	—	-230(-14000) -240(+14001)	RNAV1
Hold	ALLAN	059 (050.8)	-8.0	1.0(-14000) 1.5(+14001)	—	R	4000	—	-230(-14000) -240(+14001)	RNAV1
Hold	ASAMI	059 (050.7)	-8.0	1.0(-14000) 1.5(+14001)	—	R	4000	—	-230(-14000) -240(+14001)	RNAV1
Hold	BECKY	058 (050.2)	-8.0	1.0(-14000) 1.5(+14001)	—	R	8000	—	-230(-14000) -240(+14001)	RNAV1
Hold	BERRY	059 (050.8)	-8.0	1.0(-14000) 1.5(+14001)	—	R	4000	—	-230(-14000) -240(+14001)	RNAV1
Hold	BERTH	103 (095.4)	-8.0	1.0(-14000) 1.5(+14001)	—	R	8000	—	-230(-14000) -240(+14001)	RNAV1
Hold	CANDY	322 (313.8)	-8.0	1.0(-14000) 1.5(+14001)	—	L	9000	—	-230(-14000) -240(+14001)	RNAV1
Hold	DANDE	270 (262.6)	-8.0	1.0(-14000) 1.5(+14001)	—	L	8000	—	-230(-14000) -240(+14001)	RNAV1
Hold	DATIS	307 (298.6)	-8.0	1.0(-14000) 1.5(+14001)	—	L	6000	—	-230(-14000) -240(+14001)	RNAV1
Hold	GATES	056 (048.2)	-8.0	1.0(-14000) 1.5(+14001)	—	R	4000	—	-210(-14000) -240(+14001)	RNAV1
Hold	ISPUM	282 (274.2)	-8.0	1.0(-14000) 1.5(+14001)	—	R	8000	—	-230(-14000) -240(+14001)	RNAV1
Hold	LILAC	057 (049.2)	-8.0	1.0(-14000) 1.5(+14001)	—	R	3000	—	-230(-14000) -240(+14001)	RNAV1
Hold	MAYAH	099 (091.3)	-8.0	1.0(-14000) 1.5(+14001)	—	R	4000	—	-230(-14000) -240(+14001)	RNAV1

Waypoint Coordinates

Waypoint Identifier	Coordinates	Waypoint Identifier	Coordinates
AKASI	343522.7N/1344518.1E	CANDY	335229.8N/1345541.8E
ALISA	343042.6N/1340804.1E	DANDE	341309.4N/1352433.9E
ALLAN	341404.1N/1345728.3E	DATIS	335852.0N/1345613.1E
ASAMI	340757.9N/1344841.8E	GATES	340821.4N/1344902.6E
BECKY	335509.0N/1343030.6E	ISPUM	342548.3N/1351506.4E
BERRY	341502.0N/1345631.6E	LILAC	342710.7N/1345842.0E
BERTH	340911.4N/1341900.0E	MAYAH	343623.7N/1351211.0E

CHANGE : Coordinate at GATES.

RJBB / KANSAI INTL

Visual REP

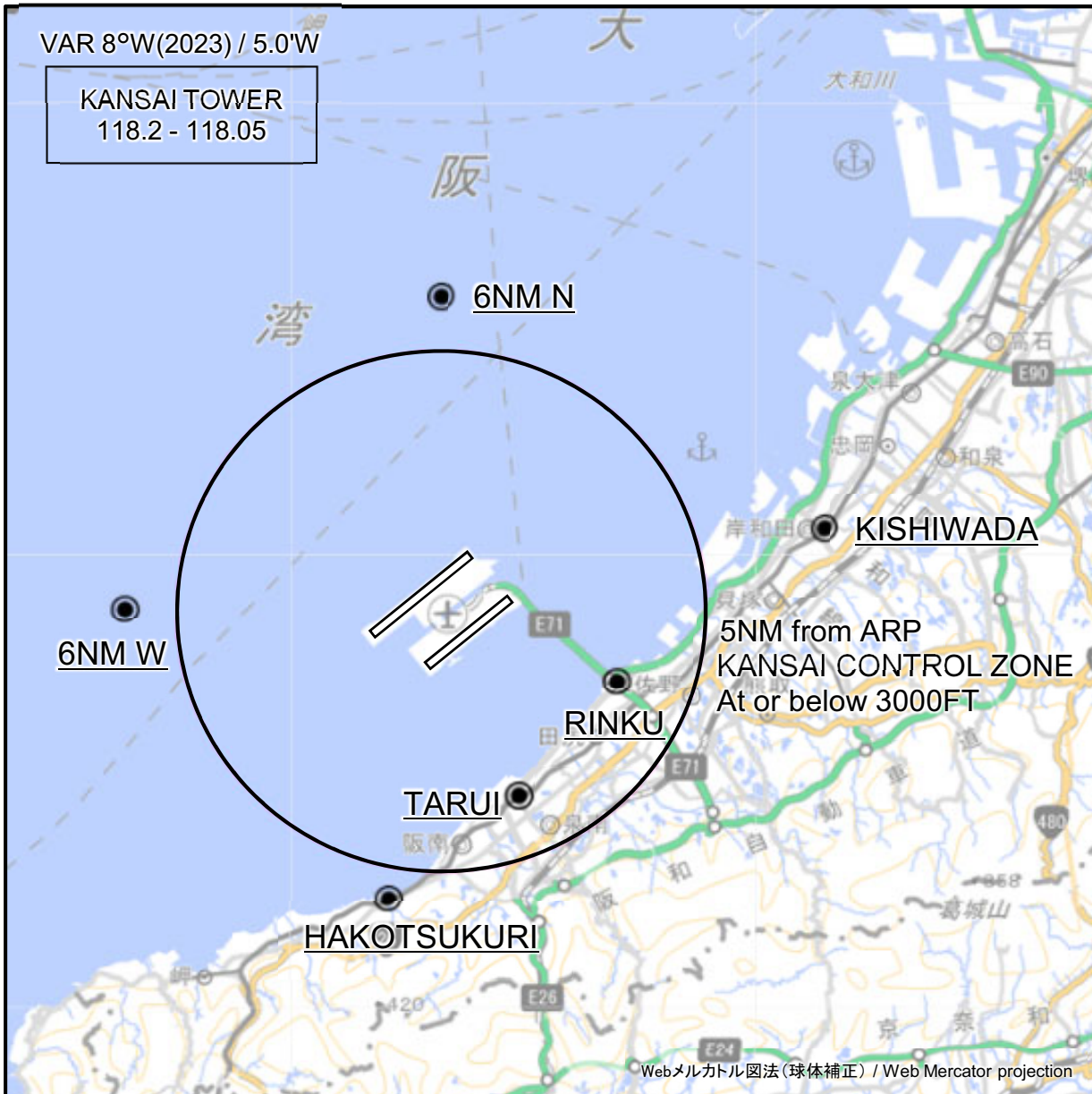

※図中に標高を示す数字がある場合、単位はメートル(m)である。The unit of measurement used to express elevation is meter(m).

CHANGE : VAR.

Call sign	BRG / DIST from ARP	Remarks
6NM N	360°T / 6.0NM	海上 Over the sea
岸和田 Kishiwada	078°T / 7.4NM	南海本線・岸和田駅 Station
6NM W	270°T / 6.0NM	海上 Over the sea
りんくう Rinku	113°T / 3.6NM	ビル Building
樽井 Tarui	158°T / 3.9NM	南海本線・樽井駅 Station
箱作 Hakotsukuri	190°T / 5.6NM	南海本線・箱作駅 Station

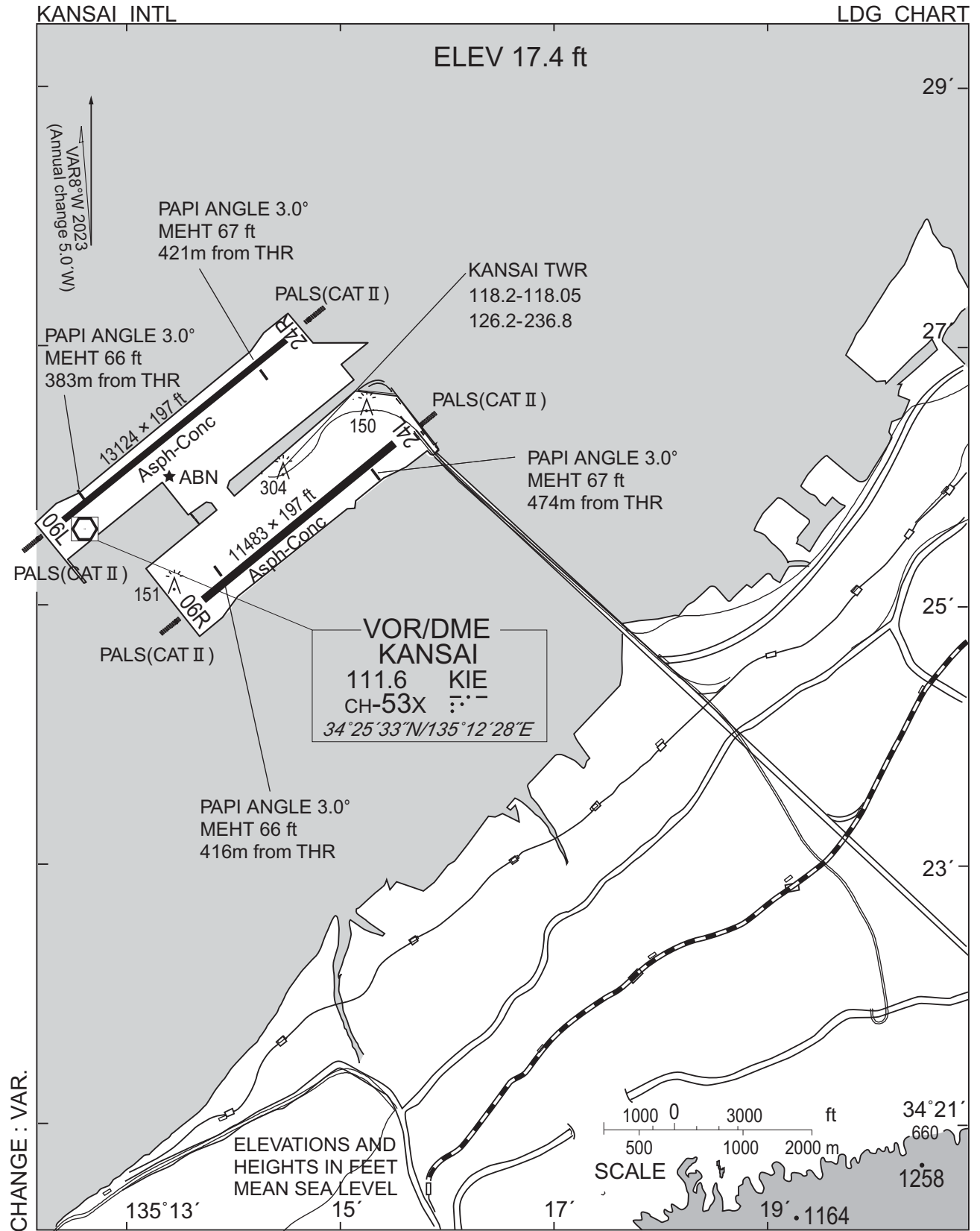

RJBB / KANSAI INTL

Minimum Vectoring Altitude CHART

VAR 8°W (2023)

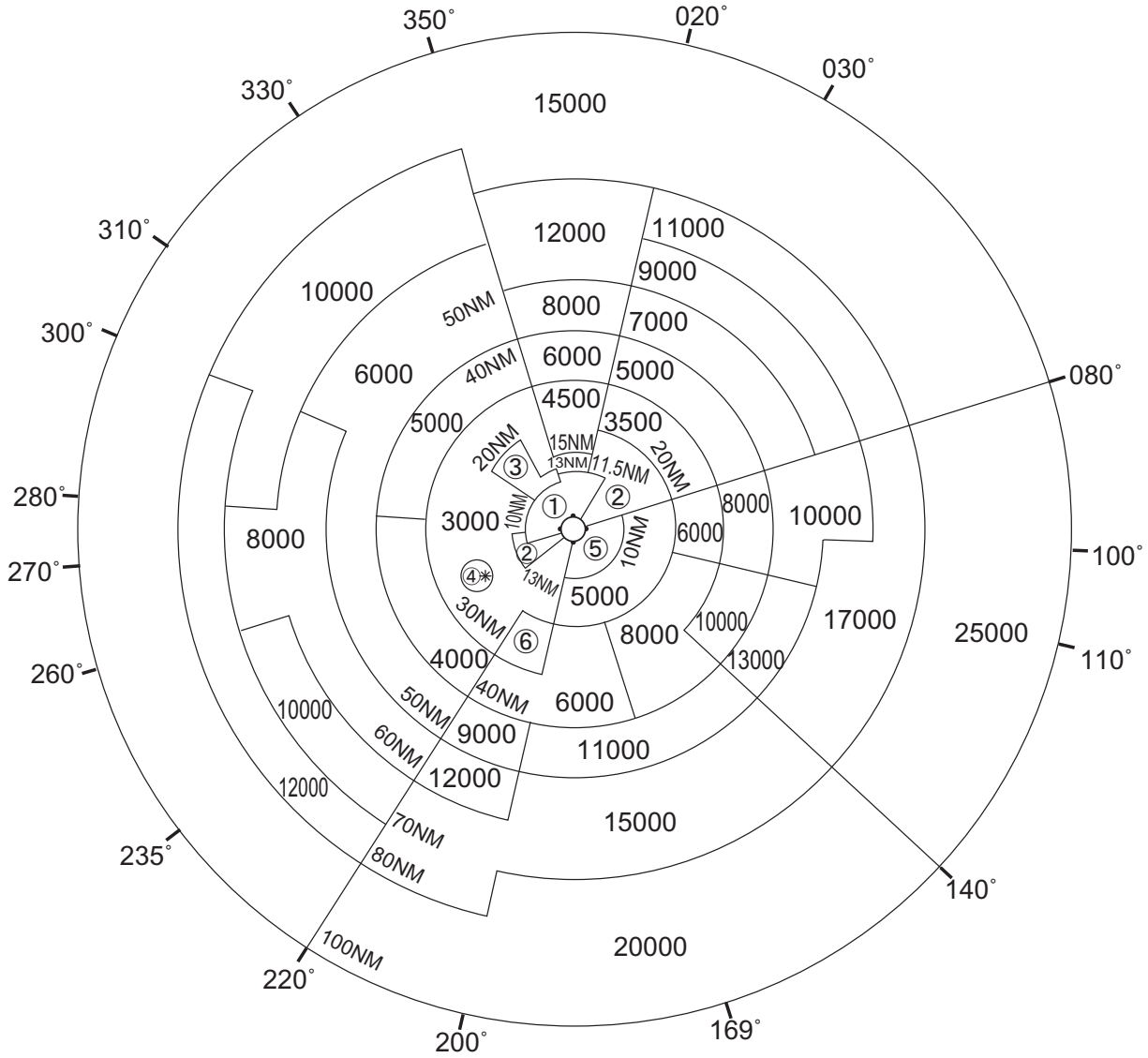

- ① 1500
- ② 2000
- ③ 2100
- ④ 3500
- ⑤ 4000
- ⑥ 5000

CENTER : 342636N/1351511E (No.1 RADAR SITE)
 CENTER : 342540N/1351343E (No.2 RADAR SITE)

* : 341405N/1344851E RADIUS : 3NM

CHANGE : VAR.