

AD 2 AERODROMES

RJCJ AD 2.1 AERODROME LOCATION INDICATOR AND NAME

RJCJ - CHITOSE

RJCJ AD 2.2 AERODROME GEOGRAPHICAL AND ADMINISTRATIVE DATA

1	ARP coordinates and site at AD	424740N 1413959E
2	Direction and distance from (city)	21nm SE Sapporo
3	Elevation/ Reference temperature	89ft / -
4	Geoid undulation at AD ELEV PSN	Nil
5	MAG VAR/ Annual change	9°W(2006) / -
6	AD Administration, address, telephone, telefax, telex, AFS, e-mail and/or Web-site addresses	JSDF-A Public AD
7	Types of traffic permitted (IFR/VFR)	IFR/VFR
8	Remarks	Nil

RJCJ AD 2.3 OPERATIONAL HOURS

1	AD Administration	H24
2	Customs and immigration	Nil
3	Health and sanitation	Nil
4	AIS Briefing Office	H24
5	ATS Reporting Office(ARO)	Nil
6	MET Briefing Office	Nil
7	ATS	H24
8	Fuelling	Nil
9	Handling	Nil
10	Security	Nil
11	De-icing	Nil
12	Remarks	Nil

RJCJ AD 2.4 HANDLING SERVICES AND FACILITIES

1	Cargo-handling facilities	Nil
2	Fuel/ oil types	JET A-1, JET A-1 PLUS
3	Fuelling facilities/ capacity	To be issued later
4	De-icing facilities	Nil
5	Hangar space for visiting aircraft	Nil
6	Repair facilities for visiting aircraft	Nil
7	Remarks	Nil

RJCJ AD 2.5 PASSENGER FACILITIES

1	Hotels	Nil
2	Restaurants	Nil
3	Transportation	Nil
4	Medical facilities	Nil
5	Bank and Post Office	Nil
6	Tourist Office	Nil
7	Remarks	Nil

RJCJ AD 2.6 RESCUE AND FIRE FIGHTING SERVICES

1	AD category for fire fighting	Nil
2	Rescue equipment	Nil
3	Capability for removal of disabled aircraft	Nil
4	Remarks	Nil

RJCJ AD 2.7 SEASONAL AVAILABILITY-CLEARING

1	Types of clearing equipment	Nil
2	Clearance priorities	Nil
3	Remarks	Nil

RJCJ AD 2.8 APRONS, TAXIWAYS AND CHECK LOCATIONS DATA

1	Apron surface and strength	To be issued later
2	Taxiway width, surface and strength	To be issued later
3	ACL and elevation	Nil
4	VOR checkpoints	Nil
5	INS checkpoints	Nil
6	Remarks	Nil

RJCJ AD 2.9 SURFACE MOVEMENT GUIDANCE AND CONTROL SYSTEM AND MARKINGS

1	Use of aircraft stand ID signs, TWY guide lines and Visual docking/ parking guidance system of aircraft stands	Nil
2	RWY and TWY markings and LGT	RWY: (LGT): REDL,RTHL, RWY DIST marker LGT, TKOF aiming LGT TWY: (LGT): TWY edge LGT
3	Stop bars	Nil
4	Remarks	Nil

RJCJ AD 2.10 AERODROME OBSTACLES

RWY/Area affected	Obstacle type	Coordinates	Elevation	Markings/ LGT	Remarks
Nil					

RJCJ AD 2.11 METEOROLOGICAL INFORMATION PROVIDED

1	Associated MET Office	CHITOSE
2	Hours of service MET Office outside hours	Nil
3	Office responsible for TAF preparation Periods of validity	Nil
4	Trend forecast Interval of issuance	Nil
5	Briefing/ consultation provided	Nil
6	Flight documentation Language(s) used	Nil
7	Charts and other information available for briefing or consultation	Nil
8	Supplementary equipment available for providing information	Doppler Radar for Airport Weather (See below figure)
9	ATS units provided with information	Nil
10	Additional information (limitation of service, etc.)	Observation is made by the Japan Defence Agency.

**Airspace for the advisory service
concerning low level wind shear (RWY18L/36R)**



UPPER LIMIT : 1600ft above FIELD ELEV LEVEL

LOWER LIMIT : FIELD ELEV LEVEL

※Only for Departing Aircraft

**Airspace for the advisory service
concerning low level wind shear (RWY18R/36L)**

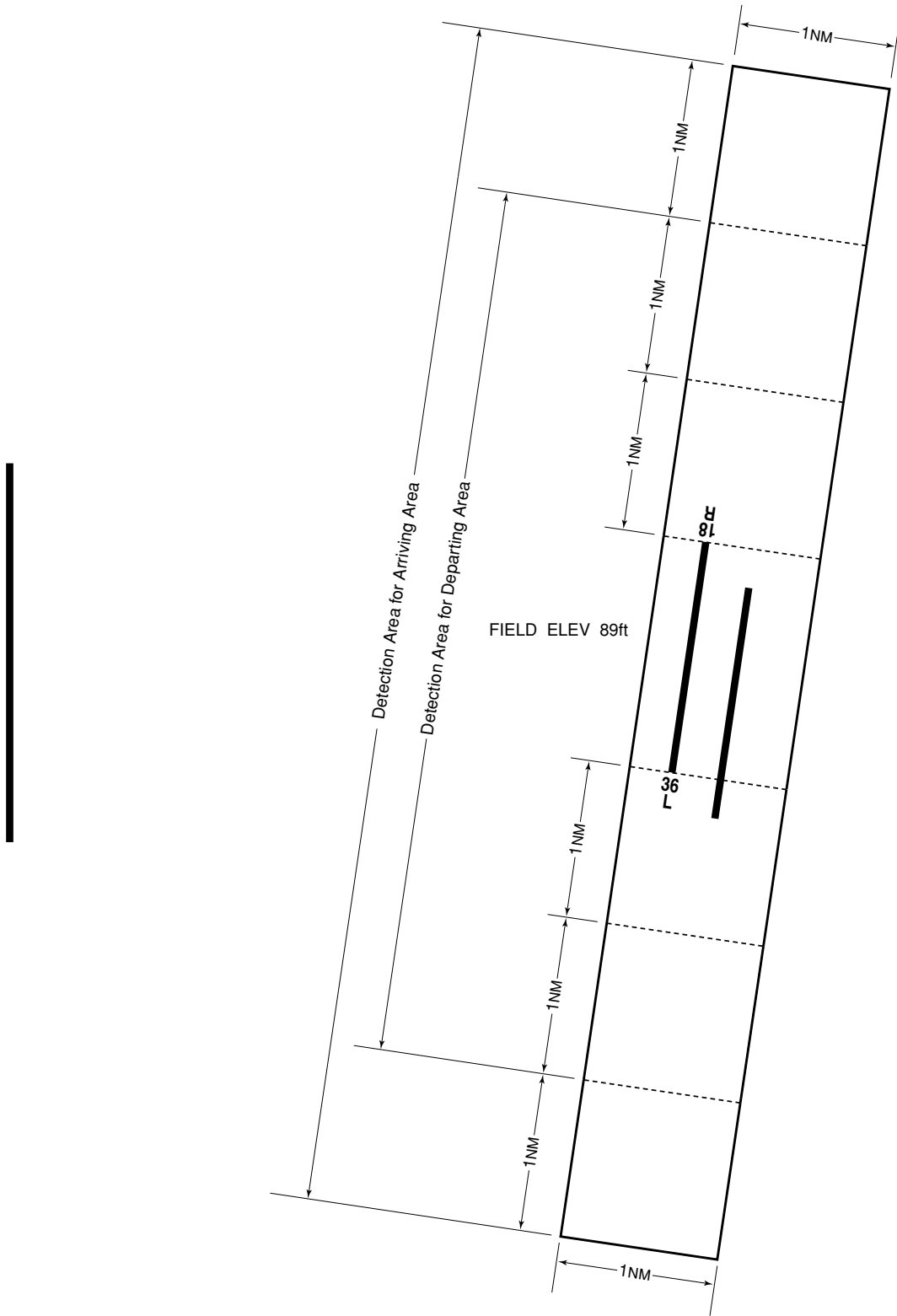

UPPER LIMIT : 1600ft above FIELD ELEV LEVEL
LOWER LIMIT : FIELD ELEV LEVEL

RJCJ AD 2.12 RUNWAY PHYSICAL CHARACTERISTICS

Designations RWY NR	TRUE BRG	Dimensions of RWY(M)	Strength(PCN) and surface of RWY	THR coordinates THR geoid undulation	THR elevation and highest elevation of TDZ of precision APP RWY
1	2	3	4	5	6
18L	172.60°	3000x60	PCN 62/R/B/X/T SW61000kg (134500lbs)	424807.32N/1414001.96E	THR ELEV : 70.0ft
36R	352.60°	3000x60	DW87000kg (191800lbs) DTW202000kg (445400lbs) Concrete	424630.79N/1414018.97E	THR ELEV : 84.6ft
18R	172.60°	2700x45	PCN 65/F/A/W/T SW20000kg (44100lbs)	424838.10N/1413943.22E	THR ELEV : 65.2ft
36L	352.60°	2700x45	DW25000kg (55100lbs) Asphalt Concrete	424711.32N/1413958.52E	THR ELEV : 86.7ft
Slope of RWY		Strip Dimensions(M)		Remarks	
7		10		12	
See AD 2.24 AD Chart		3600x300 3600x300 3300x450 3300x450		Nil	

RJCJ AD 2.13 DECLARED DISTANCES

RWY Designator	TORA (m)	TODA (m)	ASDA (m)	LDA (m)	Remarks
1	2	3	4	5	6

RJCJ AD 2.14 APPROACH AND RUNWAY LIGHTING

RWY Designator	APCH LGT type LEN INTST	RTHL Color WBAR	PAPI (VASIS) Angle DIST FM THR MEHT	RTZL LEN	RCLL LEN Spacing Color INTST	REDL LEN Spacing Color INTST	RENL Color WBAR	STWL LEN Color
1	2	3	4	5	6	7	8	9
18L	AVBL		PAPI 2.7°/Left 382.6m 52ft					
36R	AVBL		PAPI 2.7°/Left 376.5m 52ft					
18R			PAPI 2.7°/Left 379.8m 58ft					
36L			PAPI 2.7°/Left 379.5m 50ft					
Remarks								
10								

RJCJ AD 2.15 OTHER LIGHTING, SECONDARY POWER SUPPLY

1	ABN/IBN location, characteristics and hours of operation	ABN: 424833N/1413915E, White/Green EV10sec, HO
2	LDI location and LGT Anemometer location and LGT	LDI: LGTD
3	TWY edge and center line lighting	To be developed
4	Secondary power supply/ switch-over time	Nil
5	Remarks	WDI LGT, OBST LGT

RJCJ AD 2.16 HELICOPTER LANDING AREA

To be issued later

RJCJ AD 2.17 ATS AIRSPACE

Designation and lateral limits		Vertical limits (ft)	Airspace classification	ATS unit call sign Language	Remarks
1		2	3	4	6
CHITOSE CTR	(1)Area within a radius of 5nm of CHITOSE ARP (42°48'N/141°40'E) (2)Area within a radius of 5nm of New CHITOSE ARP (42°47'N/141°42'E)	6000 or below 3000 or below	D	CHITOSE TOWER En	
CHITOSE PCA	See RJCJ attached chart		E		
CHITOSE ACA	See RJCJ attached chart		E		
CHITOSE TCA	See RJCJ Attached Chart		E		

千歳特別管制区
Chitose Positive Control Area

NAME	LATERAL LIMITS	UPPER LIMIT (AMSL)	UNIT PROVIDING SERVICE	REMARKS
		LOWER LIMIT (AMSL) M(ft)		
1	2	3	4	5
千歳 Chitose	下記に示される区域 The area shown below	2450 (8000) 200 (700)	Primary Chitose APP 120.1MHz 362.3MHz Secondary Chitose TWR 118.8MHz 126.2MHz 236.8MHz	当該空域を飛行しようとする航空機は、千歳アプローチ又は千歳タワーに連絡し、コールサイン、現在位置、高度及び意図を通報し指示を受けること。 Pilot of aircraft operating in this area shall contact Chitose Approach or Chitose Tower for ATC instructions giving informations on aircraft identification, positions, altitude and pilot's intentions.

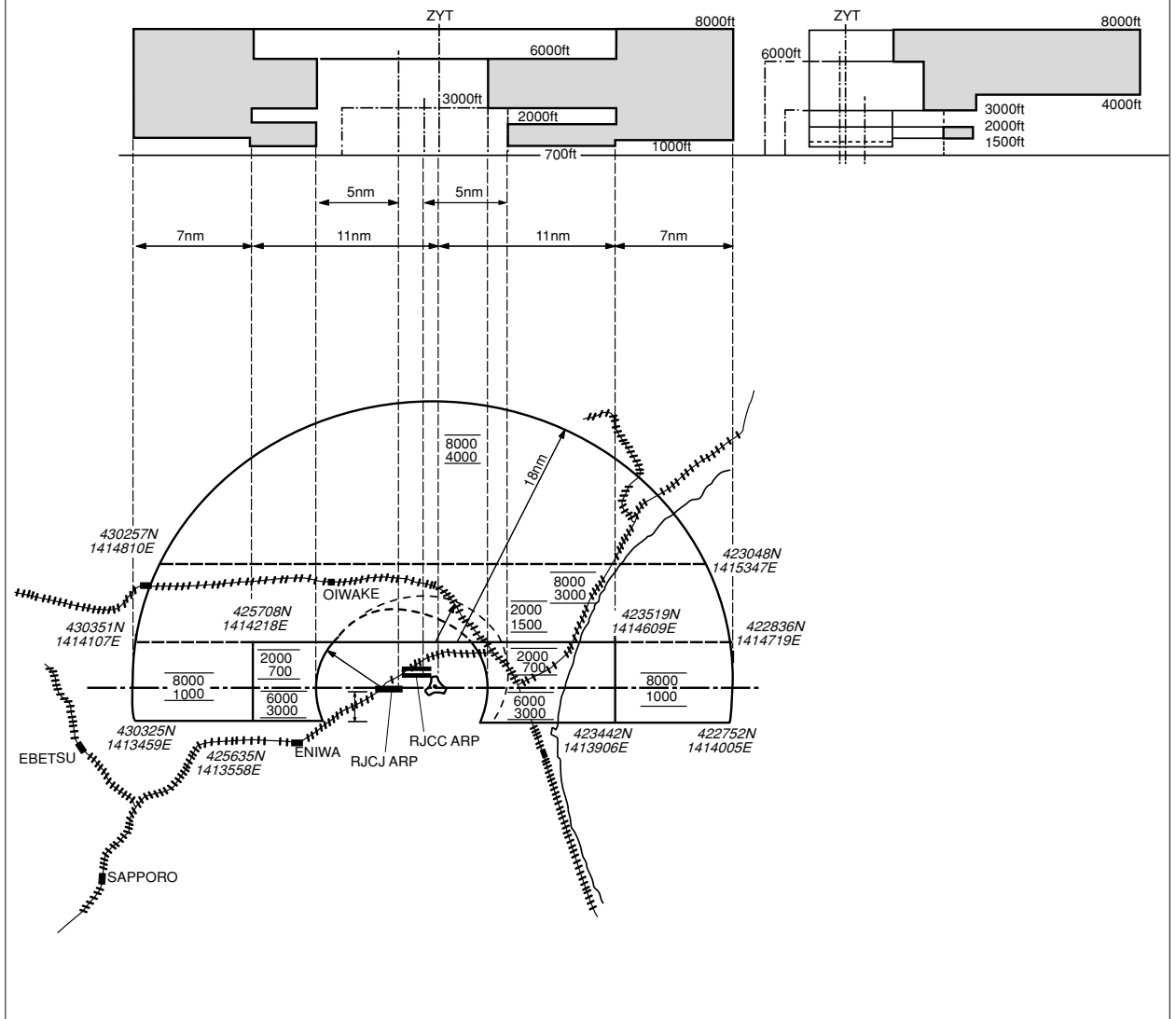

千歳進入管制区
Chitose Approach Control Area

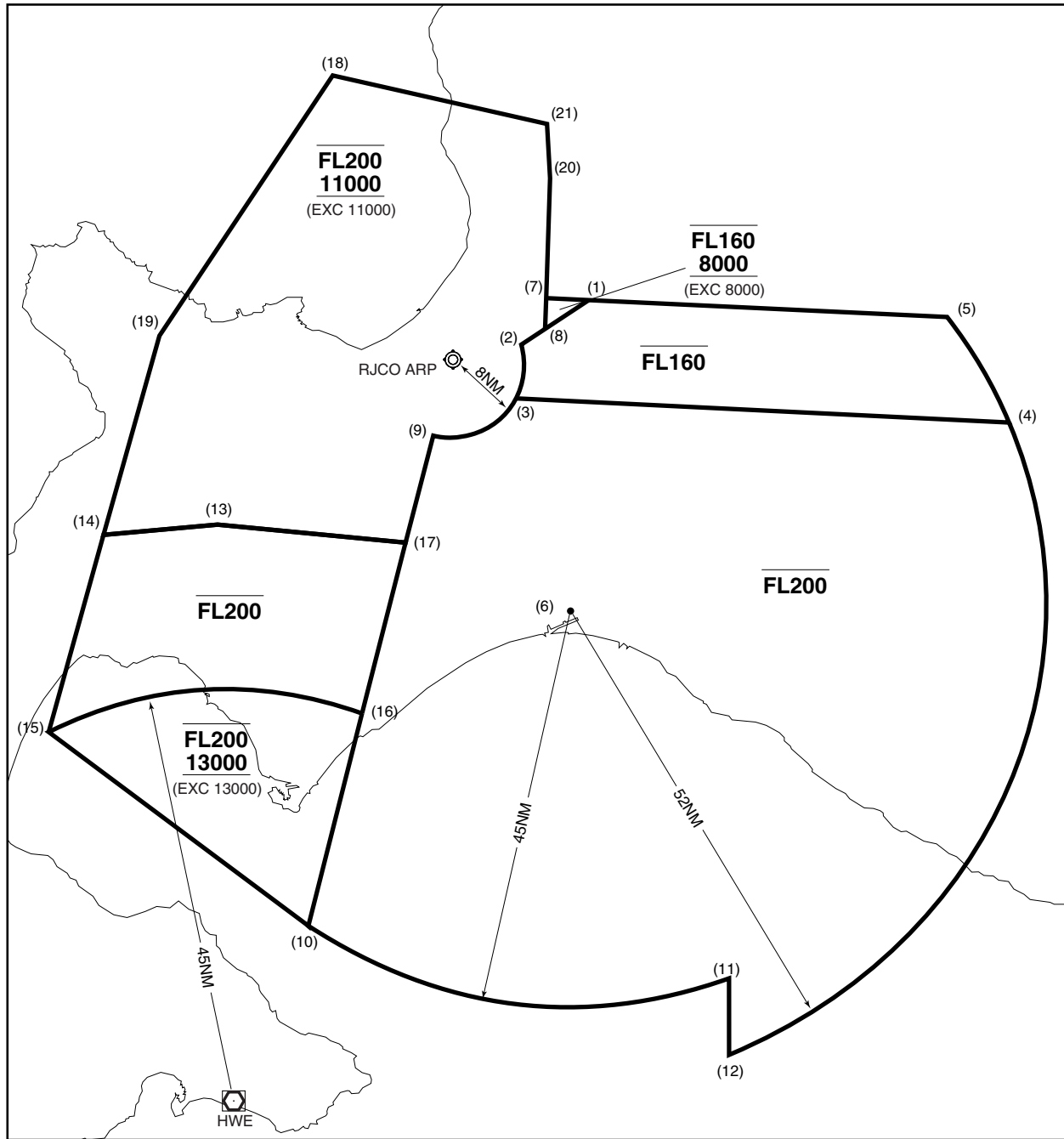

Point list

- | | | |
|-----------------------|-----------------------|-----------------------|
| (1) 431403N 1414327E | (11) 415823N 1420331E | (21) 433305N 1413715E |
| (2) 430911N 1413325E | (12) 415105N 1420410E | |
| (3) 430321N 1413234E | (13) 424936N 1404824E | |
| (4) 430055N 1424535E | (14) 424829N 1403130E | |
| (5) 431217N 1423627E | (15) 422654N 1402321E | |
| (6) 424008N 1414046E | (16) 422858N 1410950E | |
| (7) 431414N 1413708E | (17) 424739N 1411616E | |
| (8) 431055N 1413659E | (18) 433818N 1410529E | |
| (9) 425916N 1412018E | (19) 431009N 1403947E | |
| (10) 420533N 1410152E | (20) 432714N 1413742E | |

千歳ターミナルコントロールエリア
Chitose Terminal Control Area

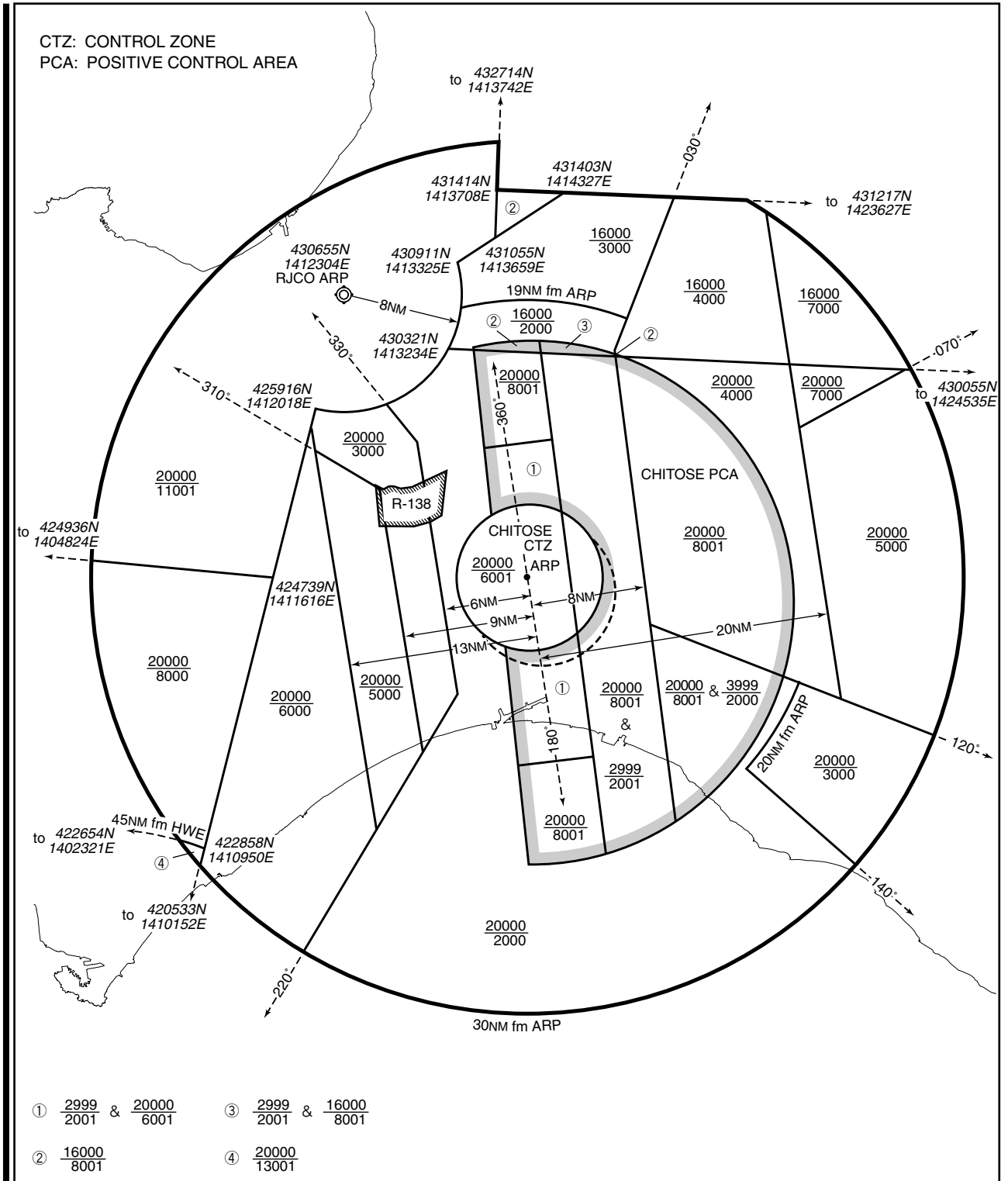

RJCJ AD 2.18 ATS COMMUNICATION FACILITIES

Service designation	Call sign	Frequency	Hours of operation	Remarks
1	2	3	4	5
APP/ASR	Chitose Approach/ Chitose Radar	362.3MHz(1) 120.1MHz(1) 305.7MHz(2) 124.7MHz(2) 243.0MHz(E) 121.5MHz(E)	H24	(1) Primary (2) Secondary
DEP	Chitose Depature	305.7MHz 124.7MHz	H24	
TCA	Chitose TCA	127.7MHz 256.1MHz	2300 - 1100 SUN-THU	
TWR	Chitose Tower	236.8MHz(1) 118.2MHz(1) 304.5MHz(2) 126.2MHz(2) 138.05MHz 247.0MHz(3)(4) 123.1MHz(3)(4) 243.0MHz(E) 121.5MHz(E)	H24	(1) Primary (2) Secondary (3) For rescue only. (4) AVBL on request.
GND	Chitose Ground	275.8MHz 121.7MHz	H24	
DLVRY	Chitose Delivery	322.2MHz 121.9MHz	H24	
MET	Chitose Metro	344.6MHz	H24	Pilot Forecaster service
GCA-ASR -PAR	Chitose Radar/ Chitose GCA	261.2MHz 119.1MHz 270.8MHz 119.5MHz 298.8MHz 124.0MHz 299.7MHz 125.3MHz 304.5MHz 131.4MHz 306.2MHz 310.8MHz 321.2MHz 335.6MHz 243.0MHz(E) 121.5MHz(E)	H24	ASR: RWY 18, 36 PAR: RWY 18, 36 Glide path: 2.7°

RJCJ AD 2.19 RADIO NAVIGATION AND LANDING AIDS

Type of aid	ID	Frequency	Hours of operation	Position of transmitting antenna coordinates	Elevation of DME transmitting antenna	Remarks
1	2	3	4	5	6	7
VOR (10°W/2020)	CHE	116.9MHz	H24	424159.65N/ 1414110.20E		
DME	CHE	1203MHz (CH-116X)	H24	424159.65N/ 1414110.20E	87ft	DME unusable: 210°-220° beyond 35nm BLW 3000ft. 220°-240° beyond 30nm BLW 3000ft. 240°-250° beyond 30nm BLW 7000ft. 260°-270° beyond 35nm BLW 7000ft. 270°-300° beyond 35nm BLW 9000ft. 300°-310° beyond 35nm BLW 7000ft.
TACAN	ZYT	990MHz (CH-29X)	H24	424552N/1414025E	128ft	Unusable: 160°-180° beyond 20nm BLW 2000ft. 180°-190° beyond 25nm BLW 2000ft. 190°-200° beyond 20nm BLW 2000ft. 200°-220° beyond 25nm BLW 2000ft. 250°-260° beyond 25nm BLW 7000ft. 260°-270° beyond 35nm BLW 9000ft. 280°-300° beyond 35nm BLW 9000ft.
ILS-LOC 36R	ICB	110.3MHz	H24	424850N/1413955E		
ILS-GP 36R	-	335.0MHz	H24	424641N/1414012E		
ILS-MM 36R	-	75.0MHz	H24	424558N/1414026E		

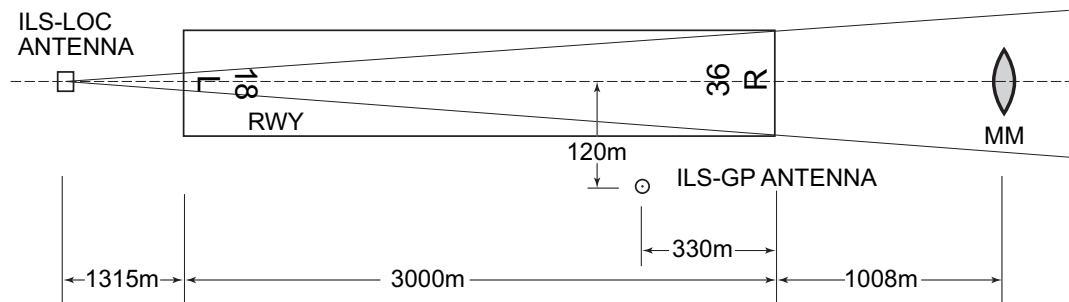

REMARKS: 1.LOC Beam BRG(MAG) 002°
2.HGT of ILS REF datum 14.7m(48ft)
3.GP angle 2.7°

RJCJ AD 2.20 LOCAL TRAFFIC REGULATIONS

1. Airport regulations

Nil

2. Taxiing to and from stands

Nil

3. Parking area for small aircraft(General aviation)

Nil

4. Parking area for helicopters

Nil

5. Apron - taxiing during winter conditions

Nil

6. Taxiing - limitations

Nil

7. School and training flights - technical test flights - use of runways

Nil

8. Helicopter traffic - limitation

Nil

9. Removal of disabled aircraft from runways

Nil

RJCJ AD 2.21 NOISE ABATEMENT PROCEDURES

Nil

RJCJ AD 2.22 FLIGHT PROCEDURES

1. TAKE OFF MINIMA					
	RWY	REDL AVBL		REDL OUT	
		CEIL-RVR	CEIL-VIS	CEIL-RVR	CEIL-VIS
TKOF ALTN AP FILED	18R	-	0'-600m	-	0'-800m
	36L	-	0'-600m	-	0'-800m
	18L	0'-600m	0'-600m	-	0'-800m
	36R	0'-600m	0'-600m	-	0'-800m
OTHER	18R	AVBL LDG MINIMA			
	36L				
	18L				
	36R				

NOTE: SIDs are designed in accordance with provisional standards for FLIGHT PROCEDURE DESIGN.

TAKE OFF MINIMA for CHITOSE REVERSAL DEPARTURE only

	RWY	ACFT CAT	REDL & RCLL		REDL or RCLL or RCL Marking		NIL (DAYTIME ONLY)	
			RVR	VIS	RVR	VIS	RVR	VIS
Multi-Engine ACFT with TKOF ALTN AP FILED	18R	A,B, C,D	-	-	-	400m	-	500m
	36L		-	-	-	400m	-	500m
	18L		-	-	400m	400m	-	500m
	36R		-	-	400m	400m	-	500m
OTHER	18R	A,B, C,D	AVBL LDG MINIMA					
	36L							
	18L							
	36R							

2. Lost communication procedures for arrival aircraft under radar navigational guidance

If radio communications with CHITOSE Radar are lost for 1 minute in the pattern or 5 seconds (PAR)/15 seconds (ASR) on final approach, squawk Mode A/3 Code 7600 and;

- (I)
 1. Contact CHITOSE Radar/Tower.
 2. If unable, proceed in accordance with visual flight rules.
 3. If unable,
 - a. proceed to ABIRA IAF at last assigned altitude or 6,000 feet whichever is higher, and execute TACAN Y RWY18L/TACAN Y RWY36R approach, as appropriate.
 - b. proceed to CHITOSE VOR/DME at last assigned altitude or 7,000 feet whichever is higher, and execute VOR or VOR/DME approach, as appropriate.
- (II) Procedures other than above will be issued when situation required.

3. Automated Radar Terminal System (ARTS)

When instructed by ATC, aircraft flying in and out of Chitose approach control area in principle will reply on 4096 Code (Mode A/3) with automatic altitude reporting capability (Mode C); Aircraft not equipped with the said transponder shall report ATC to that effect.

4. WX MINIMA CONCERNING PAR/ASR APCH PROCEDURE FOR CIVIL ACFT

PAR RWY18L

MINIMA		THR elev. 70		AD elev. 89	
CAT			CIRCLING		
	DA(H)	RVR/CMV	MDA(H)	VIS	
A	299(229)	750	620(531)	1600	
B				2400	
C				3200	
D			660(571)		3200

Simultaneous approach authorized with RJCC RWY19L(ILS) or RWY19R(ILS)
Circling to RWY36R ONLY

PAR RWY18R

MINIMA		THR elev. 65		AD elev. 89	
CAT			CIRCLING		
	DA(H)	CMV	MDA(H)	VIS	
A	276(211)	1000	700(611)	1600	
B				2400	
C				3200	
D			660(571)		3200

Simultaneous approach authorized with RJCC RWY19L(ILS) or RWY19R(ILS)

PAR RWY36L

MINIMA		THR elev. 87		AD elev. 89	
CAT			CIRCLING		
	DA(H)	CMV	MDA(H)	VIS	
A	287(200)	1000	700(611)	1600	
B				2400	
C				3200	
D			660(571)		3200

Simultaneous approach authorized with RJCC RWY01L(ILS) or RWY01R(ILS)

PAR RWY36R

MINIMA		THR elev. 85		AD elev. 89	
CAT			CIRCLING		
	DA(H)	RVR/CMV	MDA(H)	VIS	
A	287(202)	750	620(531)	1600	
B				2400	
C				3200	
D			660(571)		3200

Simultaneous approach authorized with RJCC RWY01L(ILS) or RWY01R(ILS)
Circling to RWY18L ONLY

ASR RWY18L

MINIMA		THR elev. 70		AD elev. 89	
CAT			CIRCLING		
	MDA(H)	RVR/CMV	MDA(H)	VIS	
A	700(630)	1000	700(611)	1600	
B		1200		2400	
C		1600		3200	
D		660(571)		3200	

Circling to RWY36R ONLY

ASR RWY18R

MINIMA		THR elev. 65		AD elev. 89	
CAT			CIRCLING		
	MDA(H)	CMV	MDA(H)	VIS	
A	700(635)	1500	700(611)	1600	
B		2000		2400	
C		3200			
D		660(571)		3200	

ASR RWY36L

MINIMA		THR elev. 87		AD elev. 89	
CAT			CIRCLING		
	MDA(H)	CMV	MDA(H)	VIS	
A	700(611)	1500	700(611)	1600	
B		2000		2400	
C		3200			
D		660(571)		3200	

ASR RWY36R

MINIMA		THR elev. 85		AD elev. 89	
CAT			CIRCLING		
	MDA(H)	RVR/CMV	MDA(H)	VIS	
A	700(611)	1000	700(611)	1600	
B		1200		2400	
C		3200			
D		660(571)		3200	

Circling to RWY18L ONLY

5. WX MINIMA CONCERNING PAR/ASR APCH PROCEDURE FOR JSDF ACFT

PAR RWY18L

MINIMA		THR elev. 70	AD elev. 89	
CAT			CIRCLING	
	DA(H)	RVR/CMV	MDA(H)	VIS
A	200(130)	750	620(531)	1600
B				2400
C			660(571)	3200
D				

Simultaneous approach authorized with RJCC RWY19L(ILS)
or RWY19R(ILS)
Circling to RWY36R ONLY

PAR RWY18R

MINIMA		THR elev. 65	AD elev. 89	
CAT			CIRCLING	
	DA(H)	CMV	MDA(H)	VIS
A	200(135)	1000	700(611)	1600
B				2400
C				3200
D				

Simultaneous approach authorized with RJCC RWY19L(ILS)
or RWY19R(ILS)

PAR RWY36L

MINIMA		THR elev. 87	AD elev. 89	
CAT			CIRCLING	
	DA(H)	CMV	MDA(H)	VIS
A	200(113)	1000	700(611)	1600
B				2400
C				3200
D				

Simultaneous approach authorized with RJCC RWY01L(ILS)
or RWY01R(ILS)

PAR RWY36R

MINIMA		THR elev. 85	AD elev. 89	
CAT			CIRCLING	
	DA(H)	RVR/CMV	MDA(H)	VIS
A	212(127)	750	620(531)	1600
B				2400
C			660(571)	3200
D				

Simultaneous approach authorized with RJCC RWY01L(ILS)
or RWY01R(ILS)
Circling to RWY18L ONLY

ASR RWY18L

MINIMA		THR elev. 70	AD elev. 89	
CAT			CIRCLING	
	MDA(H)	RVR/CMV	MDA(H)	VIS
A	700(630)	1000	700(611)	1600
B		1200		2400
C		1600		3200
D				

Circling to RWY36R ONLY

ASR RWY18R

MINIMA		THR elev. 65	AD elev. 89	
CAT			CIRCLING	
	MDA(H)	CMV	MDA(H)	VIS
A	700(635)	1500	700(611)	1600
B		2000		3200
C				
D				

ASR RWY36L

MINIMA		THR elev. 87	AD elev. 89	
CAT			CIRCLING	
	MDA(H)	CMV	MDA(H)	VIS
A	700(611)	1500	700(611)	1600
B		2000		3200
C				
D				

ASR RWY36R

MINIMA		THR elev. 85	AD elev. 89	
CAT			CIRCLING	
	MDA(H)	RVR/CMV	MDA(H)	VIS
A	700(611)	1000	700(611)	1600
B		1200		3200
C				
D				

Circling to RWY18L ONLY

RJCJ AD 2.23 ADDITIONAL INFORMATION

Nil

RJCJ AD 2.24 CHARTS RELATED TO AN AERODROME

Aerodrome/Heliport Chart
Standard Departure Chart - Instrument (TOKACHI)*
Standard Departure Chart - Instrument (TOBBY)*
Standard Departure Chart - Instrument (TEKKO)*
Standard Departure Chart - Instrument (HAKODATE)*
Standard Departure Chart - Instrument (CHITOSE-REVERSAL)
Standard Departure Chart - Instrument (CHITOSE)*
Standard Departure Chart - Instrument (MUKAWA)*
Standard Departure Chart - Instrument (KURIS)*
Standard Departure Chart - Instrument (SAVIT)*
Standard Departure Chart - Instrument (TRANSITION)
Standard Arrival Chart - Instrument (KOMAI)*
Standard Arrival Chart - Instrument (WAKSA-RNAV)
Instrument Approach Chart (VOR/DME NR1 RWY18L)*
Instrument Approach Chart (VOR/DME NR2 RWY18L)*
Instrument Approach Chart (VOR NR1 RWY36R)*
Instrument Approach Chart (VOR NR2 RWY36R)*
Instrument Approach Chart (ILS Z RWY36R)
Instrument Approach Chart (LOC RWY36R)
Instrument Approach Chart (ILS Y RWY36R)
Instrument Approach Chart (ILS X RWY36R)
Instrument Approach Chart (TACAN Z RWY36R)
Instrument Approach Chart (TACAN Y RWY36R)
Instrument Approach Chart (TACAN Z RWY18L)
Instrument Approach Chart (TACAN Y RWY18L)

*: Designed in accordance with provisional standards for FLIGHT PROCEDURE DESIGN.

RJCJ / CHITOSE

AD CHART

CHANGE : OVERRUN AREA EDGE LGT deleted.

CHITOSE AD

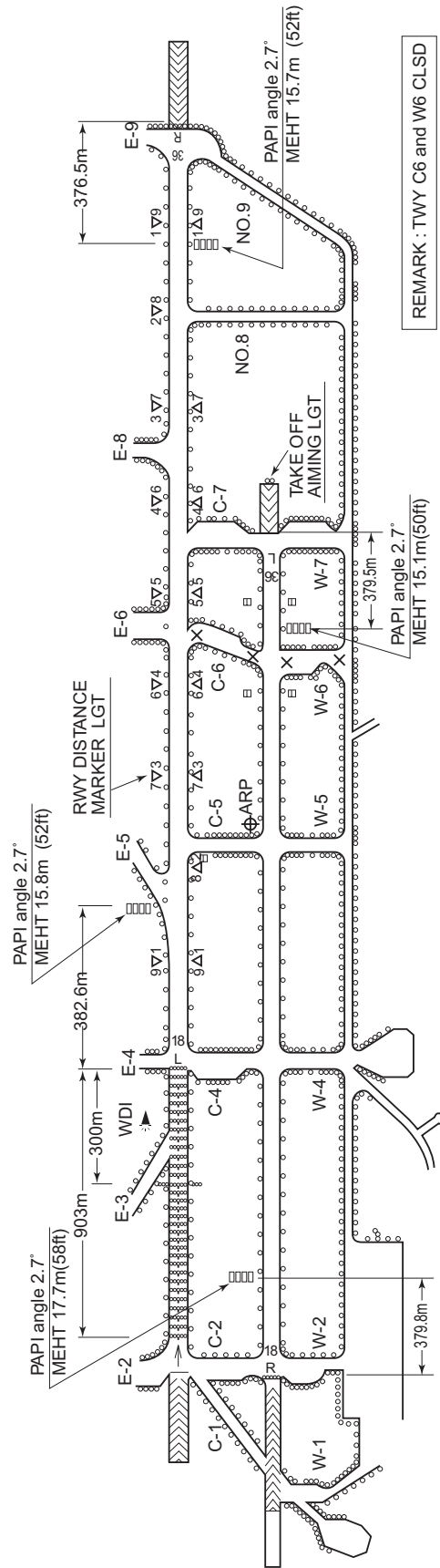

LONGITUDINAL PROFILE OF RWY

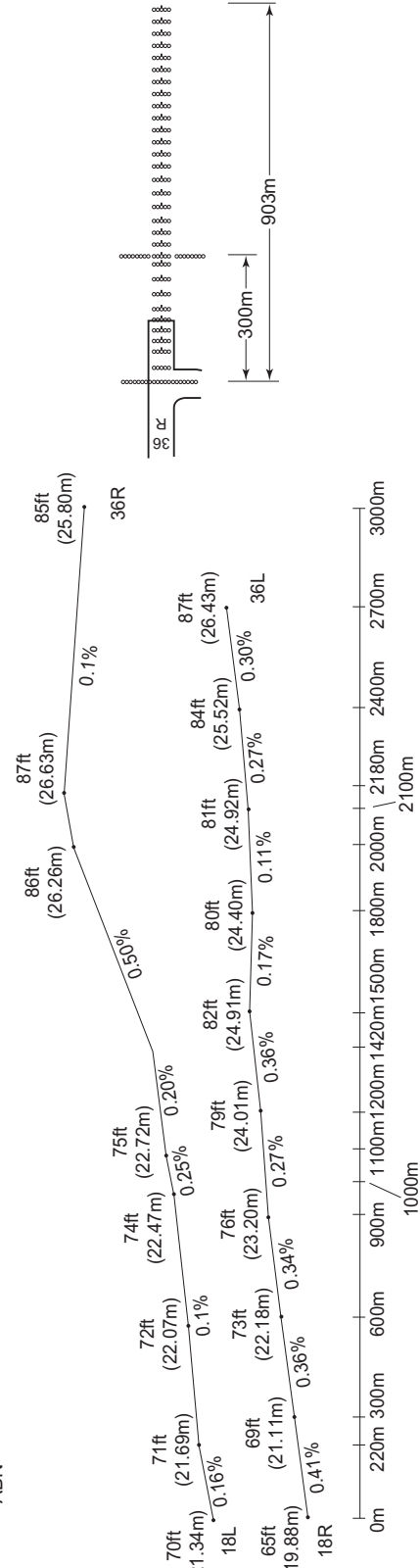

INTENTIONALLY LEFT BLANK

STANDARD DEPARTURE CHART-INSTRUMENT

RJCJ / CHITOSE

SID

TOKACHI ONE DEPARTURE

RWY 36R/36L : Climb via RWY HDG to 500ft or above, turn right climb via HDG 130 DEG to intercept and proceed via....

RWY 18R/18L : Climb via RWY HDG to 500ft or above, turn left climb via HDG 130 DEG to intercept and proceed via....

...CHE R-088 to BOKSO or CHE R-097 to RAKNO.

Cross CHE R-088/12DME or CHE R-097/12DME at or below 5,000ft.

Cross CHE R-088/22DME or CHE R-097/22DME between 9,000ft and 11,000ft.

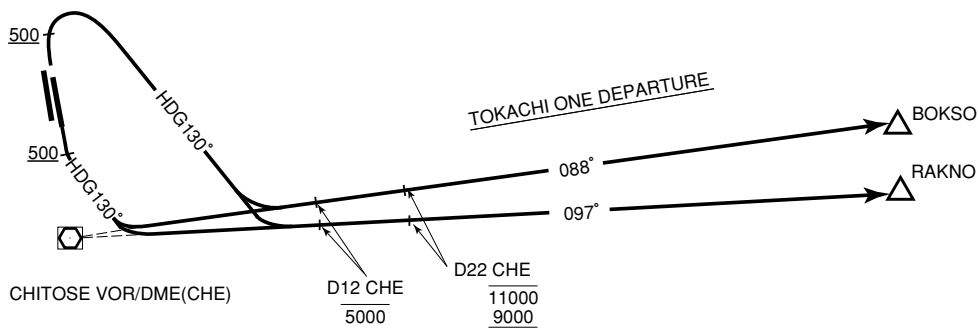

STANDARD DEPARTURE CHART-INSTRUMENT

RJCJ / CHITOSE

SID

TOBBY SEVEN DEPARTURE

RWY 36R/36L : Climb via RWY HDG to 500ft or above, turn right to CHE VOR/DME within CHE 10DME (5NM FM RWY end), then via CHE R-185 to TOBBY.

Cross 4DME prior to CHE VOR/DME (MKE R-329) at or above 3,000ft.

Cross CHE R-185/6DME at or above 6,000ft.

Cross CHE R-185/11DME at or above 7,000ft.

RWY 18R/18L : Climb direct to CHE VOR/DME, then via CHE R-185 to TOBBY.

Cross CHE R-185/27DME at or below 11,000ft.

Note : Aircraft unable to comply with the flight restriction, inform ATC for alternate procedure before departure.

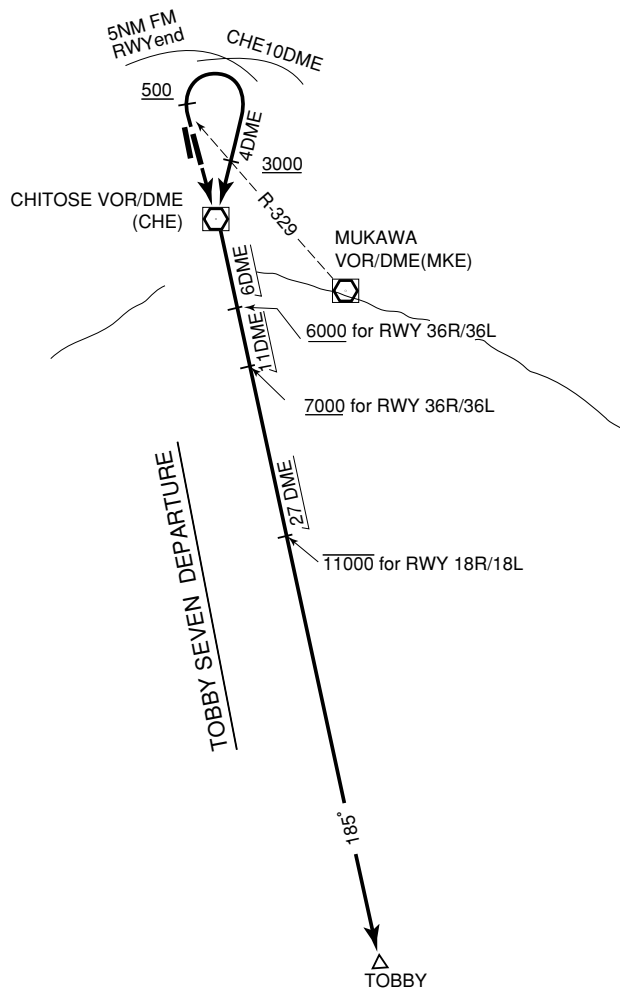

STANDARD DEPARTURE CHART-INSTRUMENT

RJCJ / CHITOSE

SID

TEKKO NINE DEPARTURE

RWY 36R/36L : Climb via RWY HDG to 500ft or above, turn right to CHE VOR/DME within CHE 10DME (5NM FM RWY end).

Cross 4DME prior to CHE VOR/DME (MKE R-329) at or above 3,000ft....

RWY 18R/18L : Climb direct to CHE VOR/DME....

....Turn right via CHE R-256 to TEKKO.

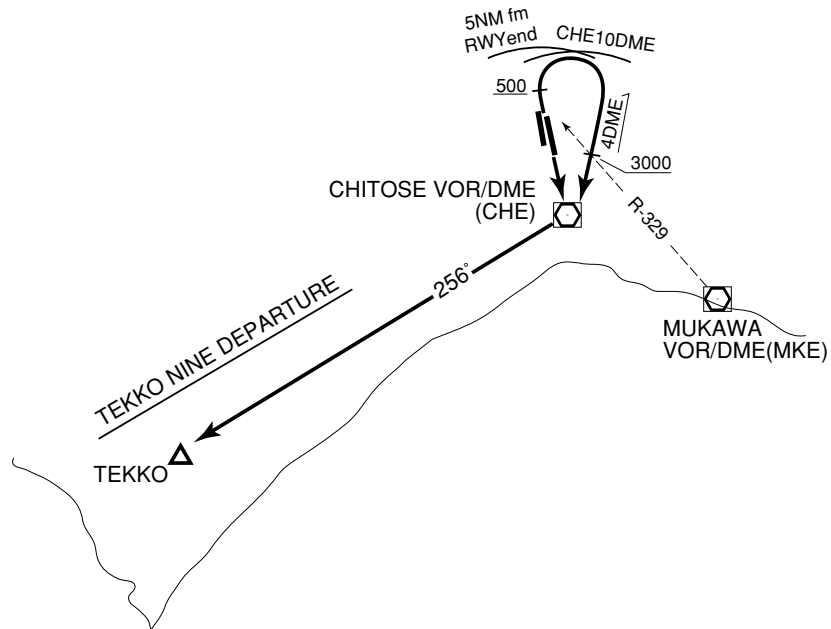

STANDARD DEPARTURE CHART-INSTRUMENT

RJCJ / CHITOSE

SID

HAKODATE FIVE DEPARTURE

- RWY 36R/36L : Climb via RWY HDG to 500ft or above, turn right to CHE VOR/DME within CHE 10DME (5NM FM RWY end).
Cross 4DME prior to CHE VOR/DME (MKE R-329) at or above 3,000ft....
- RWY 18R/18L : Climb direct to CHE VOR/DME....
....then via CHE R-224 to HWE VOR/DME.
Cross CHE R-224/8.0DME at or above 3,600ft.

HAKODATE FIVE DEPARTURE

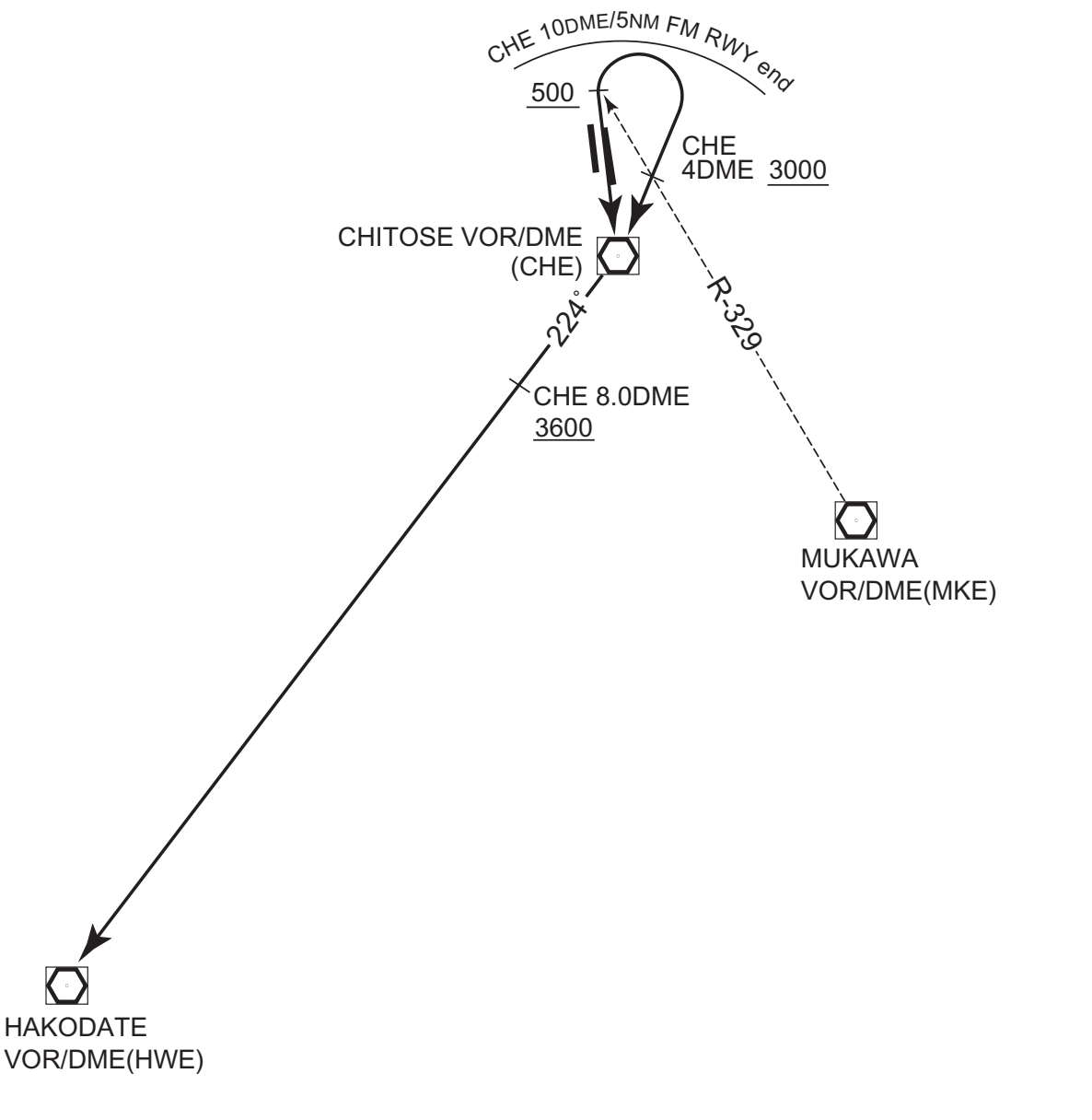

CHANGE : PROC renamed. ALT restriction added.

STANDARD DEPARTURE CHART-INSTRUMENT

RJCJ / CHITOSE

SID

CHITOSE REVERSAL THREE DEPARTURE

RWY 18L/18R : Climb RWY HDG to 600FT, turn left HDG 046° to intercept and proceed via ZYT R091 to 20.0DME, turn left, direct to ZYT TACAN.

Cross ZYT R091/15.0DME at or below 11000FT.

RWY 36R/36L : Climb via ZYT R360 to 15.0DME, turn right, direct to ZYT TACAN.

Note RWY18L : 5.0% climb gradient required up to 600FT.

OBST ALT 172FT located at 0.3NM 155° FM end of RWY18L.

RWY18R : 5.0% climb gradient required up to 600FT.

OBST ALT 197FT located at 0.6NM 205° FM end of RWY18R.

CHANGE : PROC renamed. PROC course. Note(OBST). ALT restriction. Specified ALT deleted.

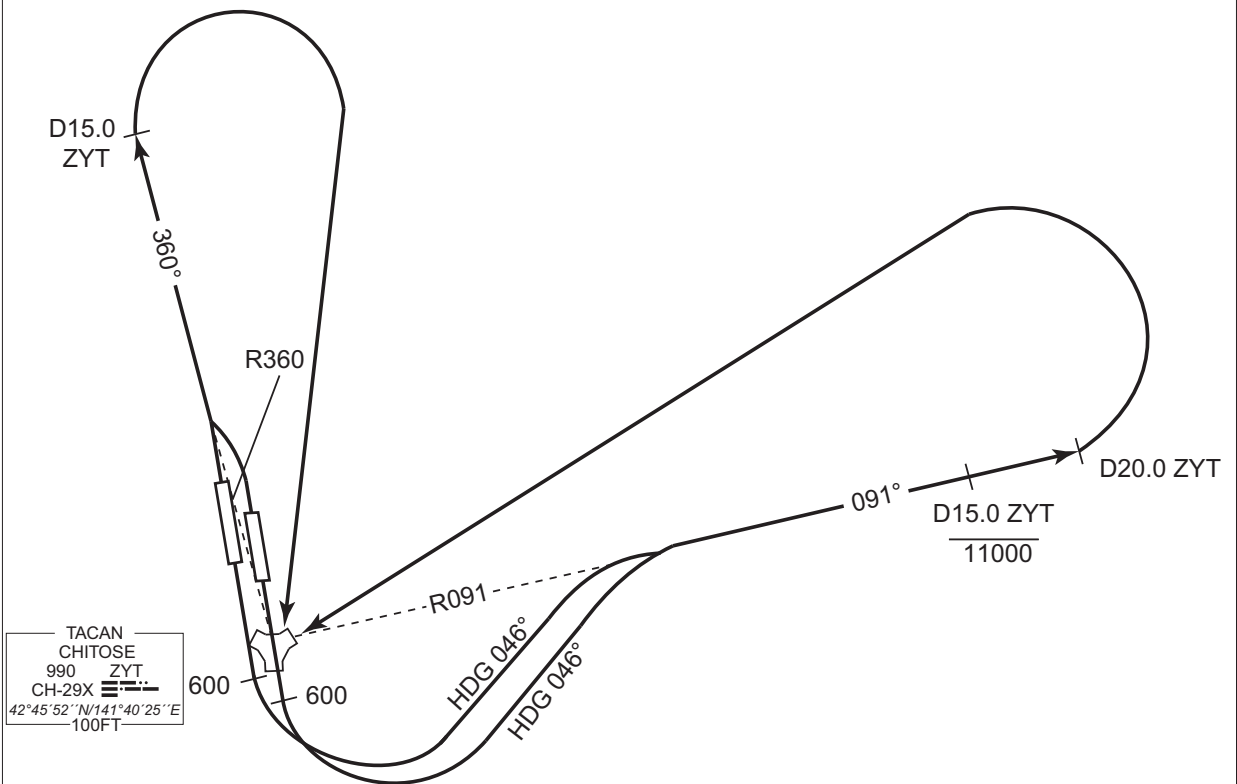

STANDARD DEPARTURE CHART-INSTRUMENT

RJCJ / CHITOSE

SID

CHITOSE FOUR DEPARTURE

RWY 18L/18R : Climb direct to CHE VOR/DME.

RWY 36R/36L : Climb via RWY HDG to 500FT or above, turn right to CHE VOR/DME within CHE 10.0DME.
Cross 4.0DME prior to CHE VOR/DME at or above 3000FT.

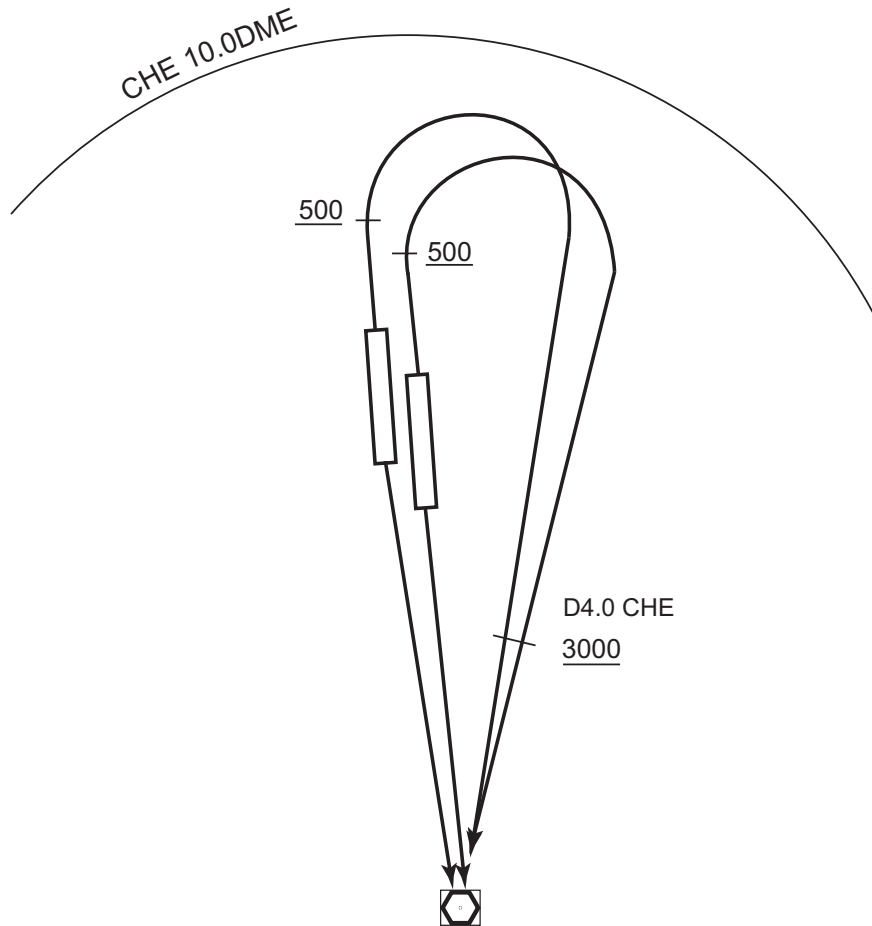

VOR/DME	
CHITOSE	
116.9	CHE
CH-116X	⋯⋯⋯
42°42'00"N/141°41'10"E	
100FT	

CHANGE : PROC renamed. PROC course. CHITOSE TACAN deleted. Note deleted.

STANDARD DEPARTURE CHART-INSTRUMENT

RJCJ / CHITOSE

SID

MUKAWA FIVE DEPARTURE

RWY 36R/36L: Climb via RWY HDG to 500ft or above, turn right within 4NM, climb via MKE R-336 to MKE VOR/DME, then via MKE R-202 to TOBBY.

Cross MKE R-336/12DME at or above 3,000ft.

Cross MKE VOR/DME at or below 11,000ft.

RWY 18R/18L: Climb via RWY HDG to 500ft or above, turn left, climb via MKE R-321 to MKE VOR/DME, then via MKE R-202 to TOBBY.

Cross MKE R-321/10DME at or above 3,000ft.

Corss MKE VOR/DME at or below 11,000ft.

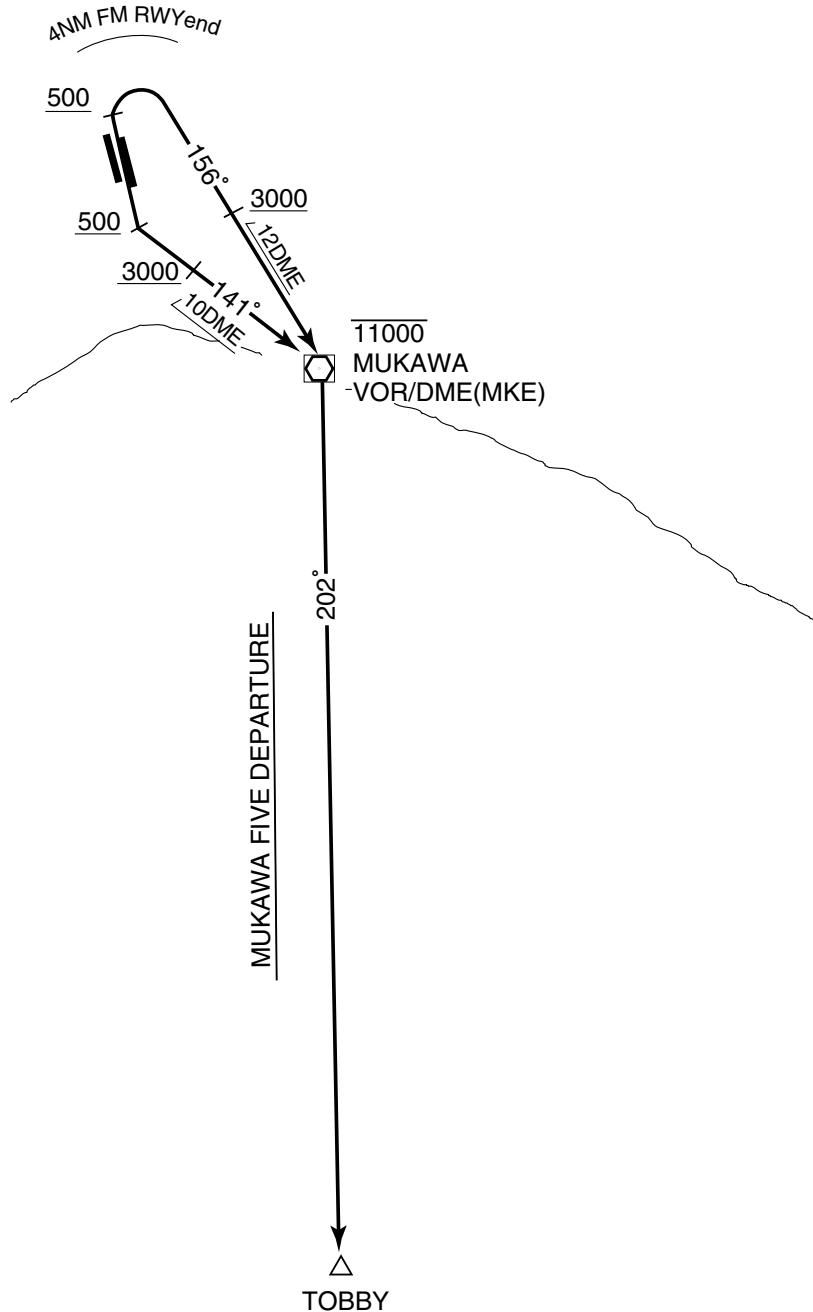

STANDARD DEPARTURE CHART-INSTRUMENT

RJCJ / CHITOSE

SID

KURIS FOUR DEPARTURE

RWY 36R/36L:

RWY 18R/18L: Climb via RWY HDG to 500ft or above, turn left within 4NM,...

....climb via CHE R-011 to KURIS.

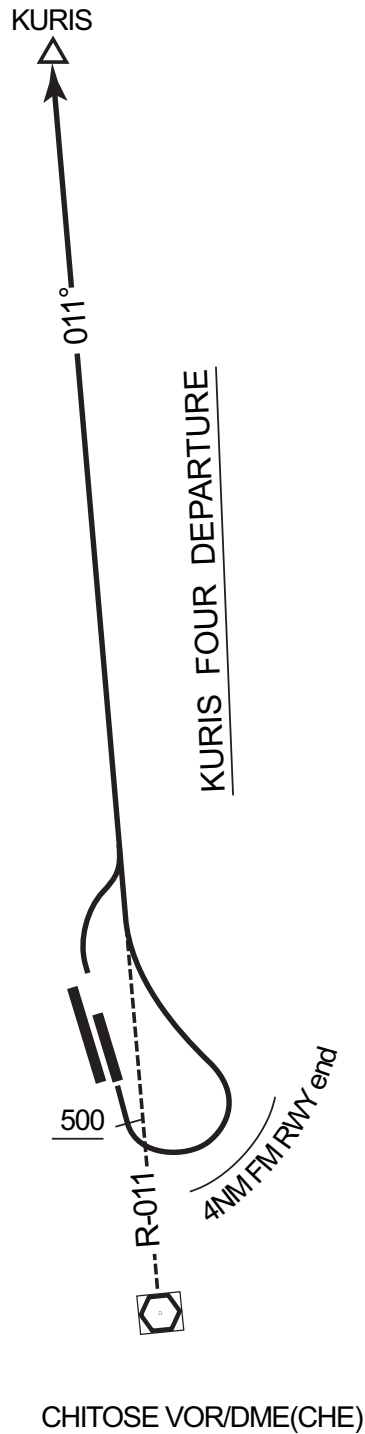

STANDARD DEPARTURE CHART-INSTRUMENT

RJCJ / CHITOSE

SID

SAVIT TWO DEPARTURE

- RWY 36R/36L : Climb via RWY HDG to 500ft or above, turn right to CHE VOR/DME within CHE 10DME (5NM FM RWY end).
Cross 4DME prior to CHE VOR/DME (MKE R-329) at or above 3,000ft....
- RWY 18R/18L : Climb direct to CHE VOR/DME....
....then via CHE R-224 to SAVIT.
Cross CHE R-224/8.0DME at or above 3,600ft.

SAVIT TWO DEPARTURE

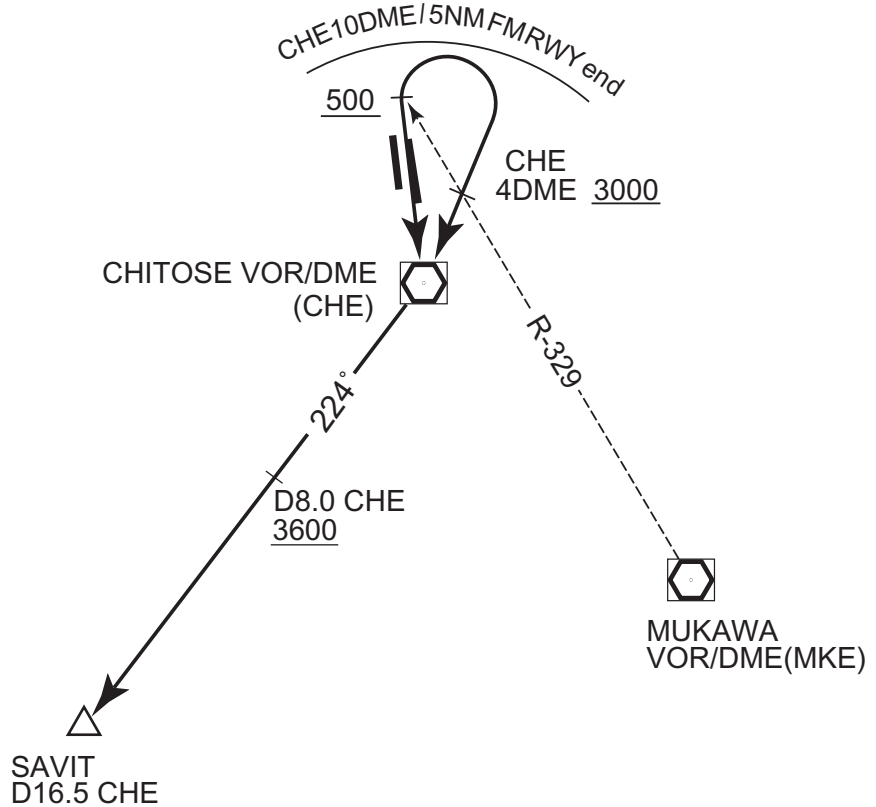

CHANGE : PROC renamed. ALT restriction added.

STANDARD DEPARTURE CHART-INSTRUMENT

RJCJ / CHITOSE

RNAV TRANSITION

PANSY TRANSITION/BUTOS TRANSITION		RNAV 1
Note 1) DME/DME/IRU or GNSS required. 2) RADAR service required.	Critical DME	-
	DME GAP	-
	Inappropriate Nav aids	See AD1.1.6.10.3 Inappropriate NAV AIDs for RNAV1

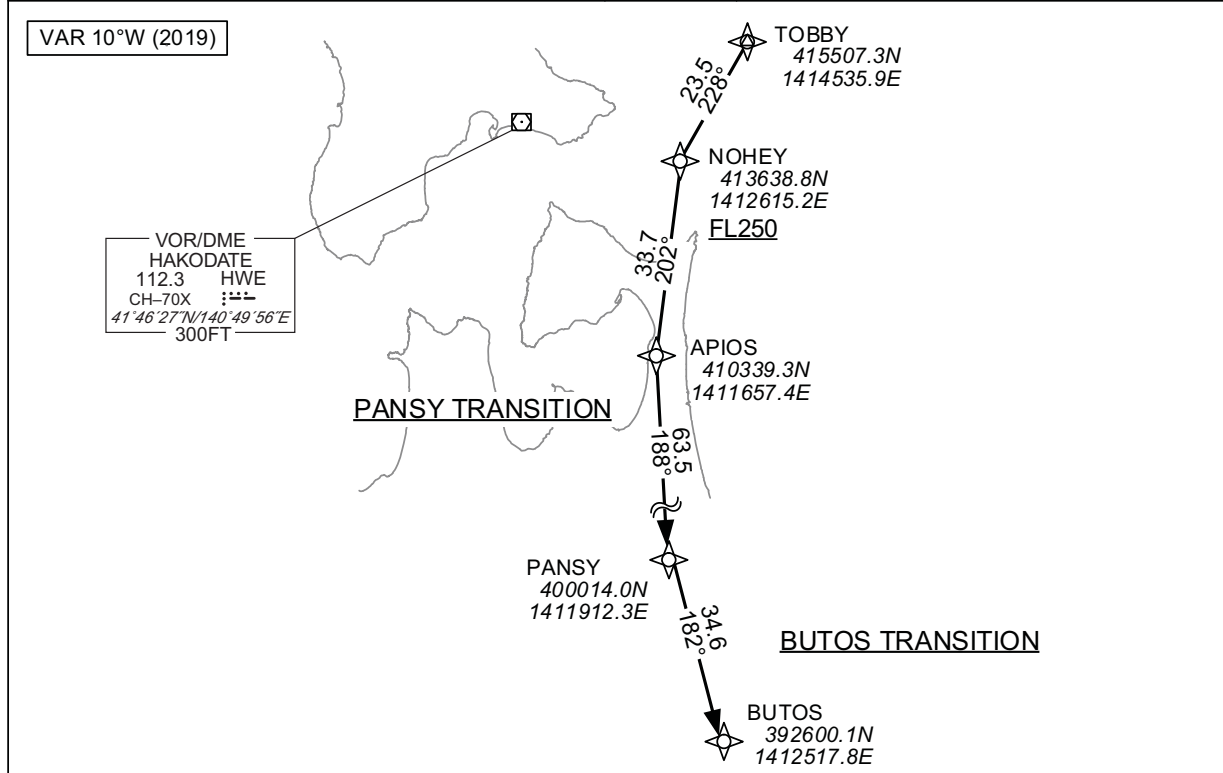

PANSY TRANSITION

From TOBBY, to NOHEY at or above FL250, to APIOS, to PANSY.

Serial Number	Path Descriptor	Waypoint Identifier	Fly Over	Course °M(°T)	Magnetic Variation	Distance (NM)	Turn Direction	Altitude (FT)	Speed (KIAS)	Vertical Angle	Navigation Specification
001	IF	TOBBY	-	-	-9.5	-	-	-	-	-	RNAV1
002	TF	NOHEY	-	228 (218.1)	-9.5	23.5	-	+FL250	-	-	RNAV1
003	TF	APIOS	-	202 (192.0)	-9.5	33.7	-	-	-	-	RNAV1
004	TF	PANSY	-	188 (178.4)	-9.5	63.5	-	-	-	-	RNAV1

BUTOS TRANSITION

From TOBBY, to NOHEY at or above FL250, to APIOS, to PANSY, to BUTOS.

Serial Number	Path Descriptor	Waypoint Identifier	Fly Over	Course °M(°T)	Magnetic Variation	Distance (NM)	Turn Direction	Altitude (FT)	Speed (KIAS)	Vertical Angle	Navigation Specification
001	IF	TOBBY	-	-	-9.5	-	-	-	-	-	RNAV1
002	TF	NOHEY	-	228 (218.1)	-9.5	23.5	-	+FL250	-	-	RNAV1
003	TF	APIOS	-	202 (192.0)	-9.5	33.7	-	-	-	-	RNAV1
004	TF	PANSY	-	188 (178.4)	-9.5	63.5	-	-	-	-	RNAV1
005	TF	BUTOS	-	182 (172.2)	-9.5	34.6	-	-	-	-	RNAV1

STANDARD DEPARTURE CHART-INSTRUMENT

RJCJ / CHITOSE

RNAV TRANSITION

SHUYU TRANSITION		RNAV1
Note 1) DME/DME/IRU or GNSS required. 2) RADAR service required.	Critical DME	-
	DME GAP	-
	Inappropriate Nav aids	See AD1.1.6.10.3. Inappropriate NAVAIDs for RNAV1

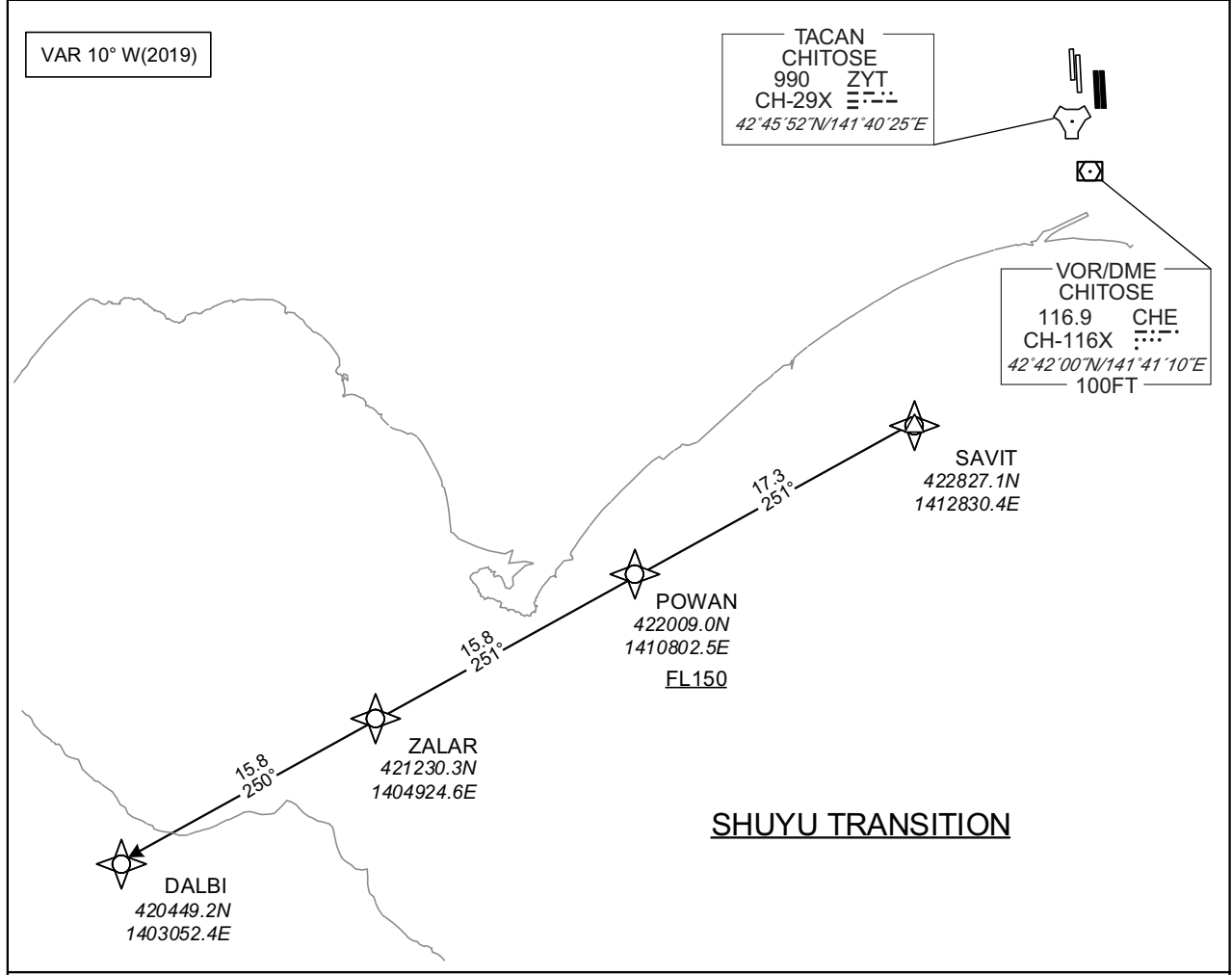

SHUYU TRANSITION

From SAVIT, to POWAN at or above FL150, to ZALAR, to DALBI.

Serial Number	Path Descriptor	Waypoint Identifier	Fly Over	Course °M(°T)	Magnetic Variation	Distance (NM)	Turn Direction	Altitude (FT)	Speed (KIAS)	Vertical Angle	Navigation Specification
001	IF	SAVIT	-	-	-9.5	-	-	-	-	-	RNAV1
002	TF	POWAN	-	251 (241.3)	-9.5	17.3	-	+FL150	-	-	RNAV1
003	TF	ZALAR	-	251 (241.1)	-9.5	15.8	-	-	-	-	RNAV1
004	TF	DALBI	-	250 (240.9)	-9.5	15.8	-	-	-	-	RNAV1

STANDARD DEPARTURE CHART-INSTRUMENT

RJCJ / CHITOSE

RNAV TRANSITION

FUNKA TRANSITION		RNAV1
Note 1) DME/DME/IRU or GNSS required. 2) RADAR service required.	Critical DME	MRE : 12.0NM to FUNKA - FUNKA
	DME GAP	-
	Inappropriate Nav aids	See AD1.1.6.10.3. Inappropriate NAVAIDs for RNAV1

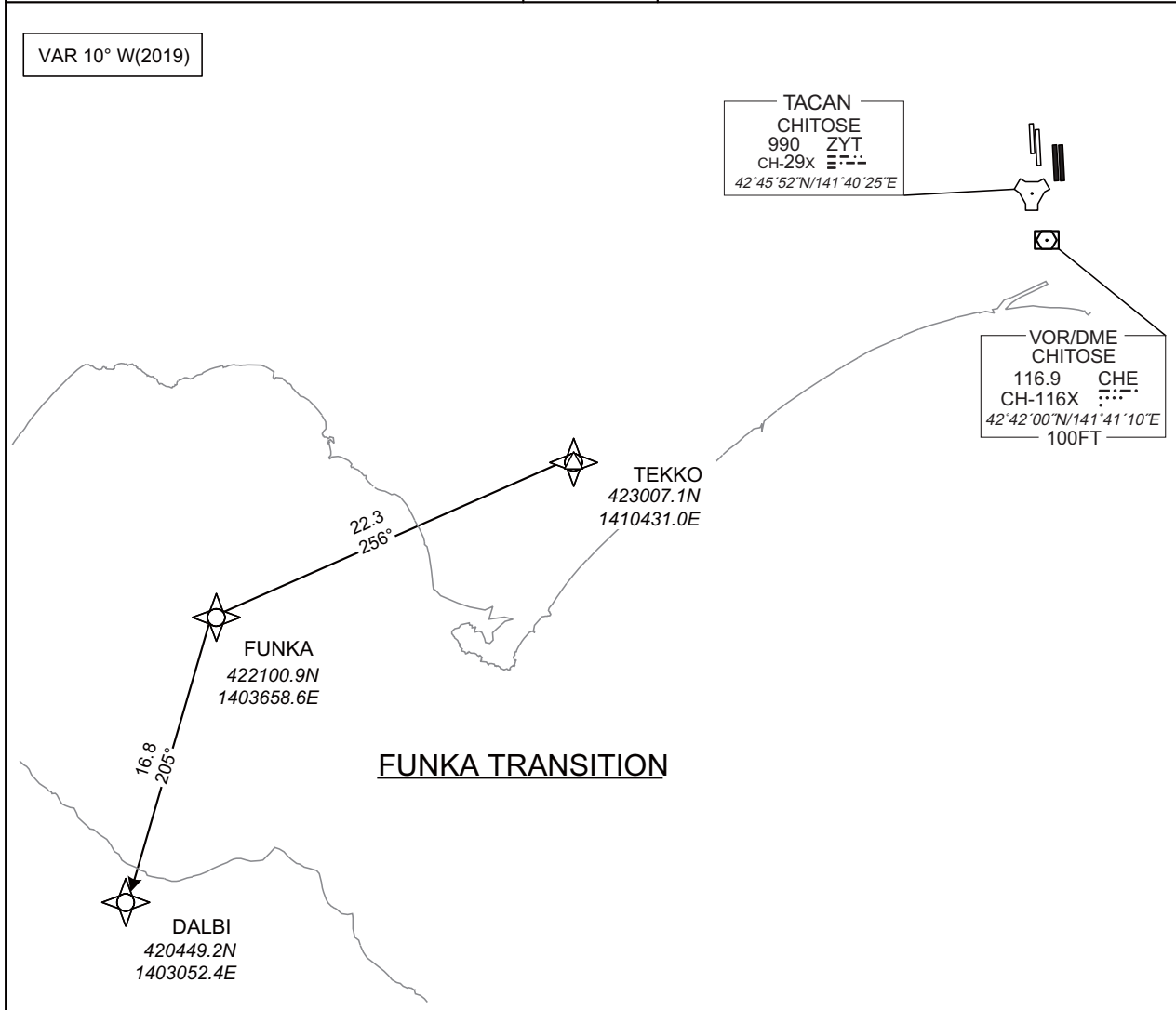

FUNKA TRANSITION

From TEKKO, to FUNKA, to DALBI.

Serial Number	Path Descriptor	Waypoint Identifier	Fly Over	Course °M(°T)	Magnetic Variation	Distance (NM)	Turn Direction	Altitude (FT)	Speed (KIAS)	Vertical Angle	Navigation Specification
001	IF	TEKKO	-	-	-9.5	-	-	-	-	-	RNAV1
002	TF	FUNKA	-	256 (246.0)	-9.5	22.3	-	-	-	-	RNAV1
003	TF	DALBI	-	205 (195.6)	-9.5	16.8	-	-	-	-	RNAV1

STANDARD ARRIVAL CHART-INSTRUMENT

RJCJ / CHITOSE

STAR

STARs for RWY36

KOMAI WEST ARRIVAL

From over NAVER, via CHE R-201 to intercept and proceed via MKE R-241 to KOMAI.

KOMAI EAST ARRIVAL

From over MKE VOR/DME, via MKE R-180 to MKE R-180/8DME, turn right, proceed via HDG 270 DEG to intercept MKE R-221, then turn right to intercept CHE R-181 to KOMAI.

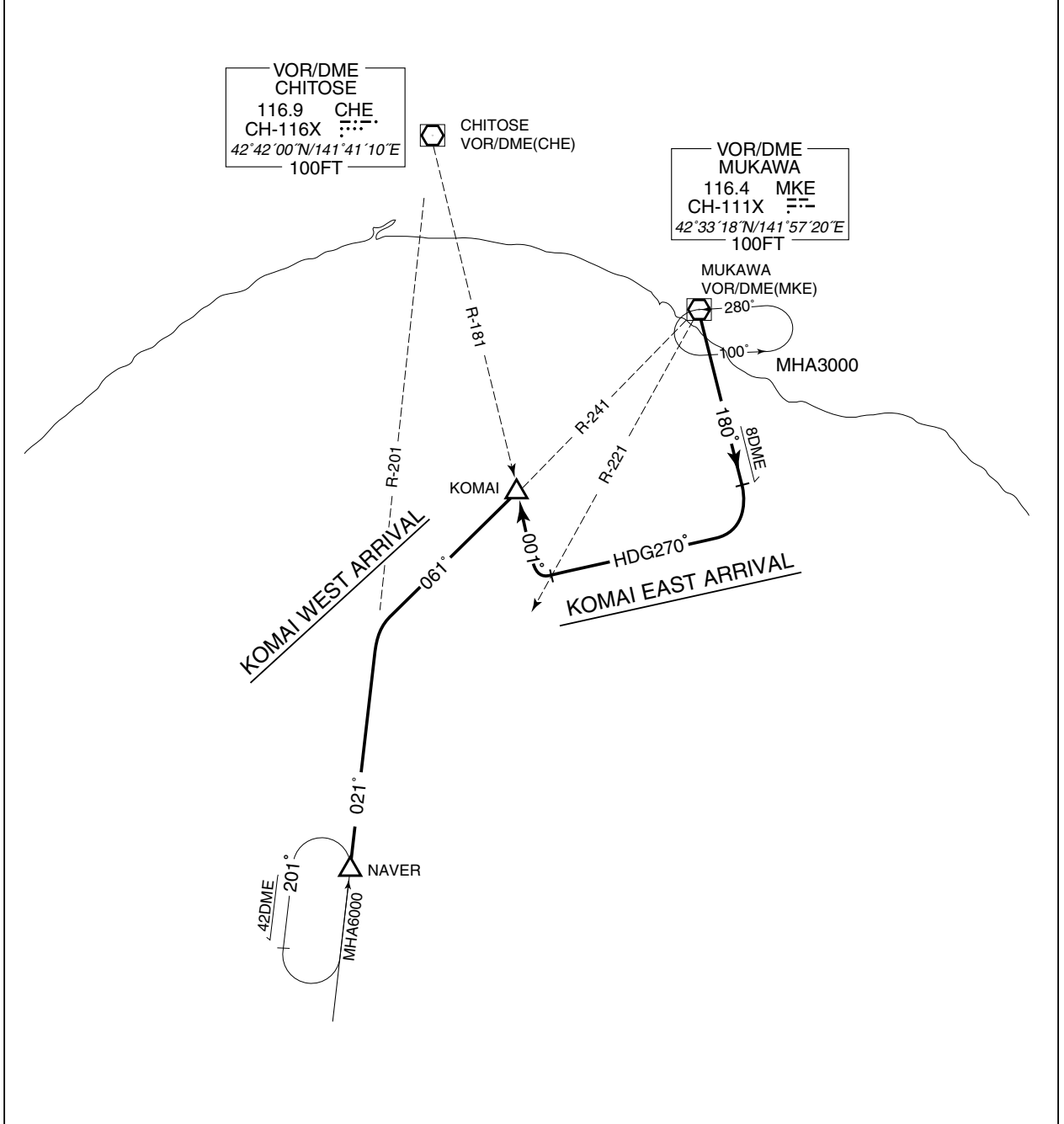

STANDARD ARRIVAL CHART-INSTRUMENT

RJCJ / CHITOSE

RNAV STAR RWY18L

WAKSA ALFA ARRIVAL
WAKSA BRAVO ARRIVAL

RNAV 1

Note 1) DME/DME/IRU or GNSS required.
2) RADAR service required.

VAR 9° W(2016)

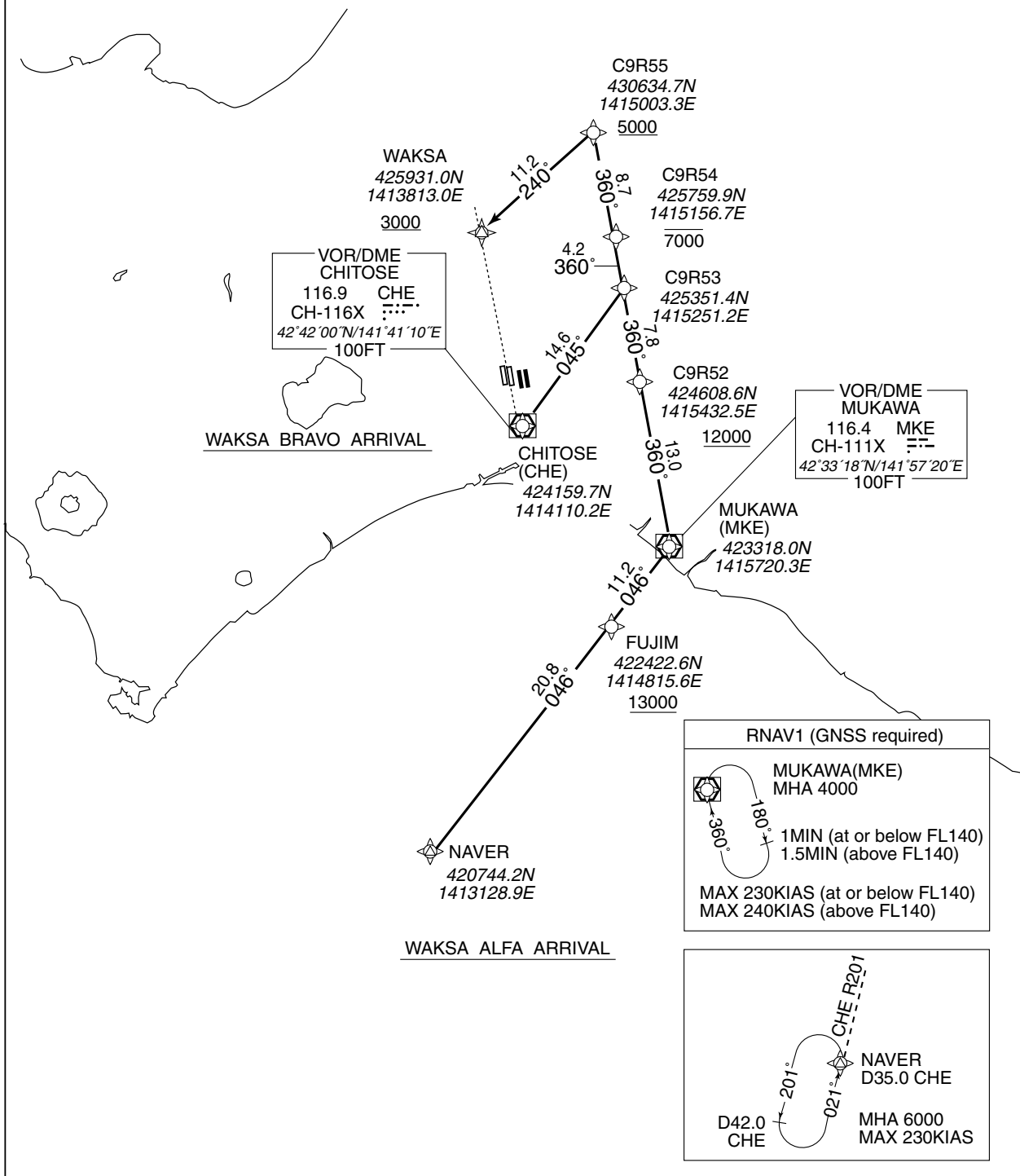

STANDARD ARRIVAL CHART-INSTRUMENT

RJCJ / CHITOSE

RNAV STAR RWY18L

WAKSA ALFA ARRIVAL

From NAVER, to FUJIM at or above 13000FT, to MKE, to C9R52 at or above 12000FT, to C9R53, to C9R54 at or below 7000FT, to C9R55 at or above 5000FT, to WAKSA at or above 3000FT.

Critical DME	SPE: C9R55 - WAKSA MKE: 10.0NM to MKE - 3.0NM to MKE 10.0NM to C9R52 - 8.0NM to C9R52
DME GAP	3.0NM to MKE - 10.0NM to C9R52
Inappropriate Navaids	See AD1.1.6.10.3. Inappropriate NAVAIDs for RNAV1

Serial Number	Path Descriptor	Waypoint Identifier	Fly Over	Course °M(°T)	Magnetic Variation	Distance (NM)	Turn Direction	Altitude (FT)	Speed (KIAS)	Vertical Angle	Navigation Specification
001	IF	NAVER	—	—	-9.3	—	—	—	—	—	RNAV1
002	TF	FUJIM	—	046 (036.6)	-9.3	20.8	—	+13000	—	—	RNAV1
003	TF	MKE	—	046 (036.8)	-9.3	11.2	—	—	—	—	RNAV1
004	TF	C9R52	—	360 (350.9)	-9.3	13.0	—	+12000	—	—	RNAV1
005	TF	C9R53	—	360 (350.9)	-9.3	7.8	—	—	—	—	RNAV1
006	TF	C9R54	—	360 (350.9)	-9.3	4.2	—	-7000	—	—	RNAV1
007	TF	C9R55	—	360 (350.9)	-9.3	8.7	—	+5000	—	—	RNAV1
008	TF	WAKSA	—	240 (230.8)	-9.3	11.2	—	+3000	—	—	RNAV1

Path	Waypoint Identifier	Inbound Course °M(°T)	Magnetic Variation	Outbound Time (MIN)	Turn Direction	Minimum Altitude (FT)	Maximum Altitude (FT)	Speed (KIAS)	Navigation Specification
Hold	MUKAWA (MKE)	360 (350.9)	-9.3	1.0(-14000) 1.5(+14001)	R	4000	—	-230(-14000) -240(+14001)	RNAV1

STANDARD ARRIVAL CHART-INSTRUMENT

RJCJ / CHITOSE

RNAV STAR RWY18L

WAKSA BRAVO ARRIVAL

From CHE, to C9R53, to C9R54 at or below 7000FT, to C9R55 at or above 5000FT, to WAKSA at or above 3000FT.

Critical DME	SPE: C9R55 - WAKSA
DME GAP	CHE - 11.0NM to C9R53
Inappropriate Nav aids	See AD1.1.6.10.3. Inappropriate NAVAIDs for RNAV1

Serial Number	Path Descriptor	Waypoint Identifier	Fly Over	Course °M(°T)	Magnetic Variation	Distance (NM)	Turn Direction	Altitude (FT)	Speed (KIAS)	Vertical Angle	Navigation Specification
001	IF	CHE	—	—	-9.3	—	—	—	—	—	RNAV1
002	TF	C9R53	—	045 (035.8)	-9.3	14.6	—	—	—	—	RNAV1
003	TF	C9R54	—	360 (350.9)	-9.3	4.2	—	-7000	—	—	RNAV1
004	TF	C9R55	—	360 (350.9)	-9.3	8.7	—	+5000	—	—	RNAV1
005	TF	WAKSA	—	240 (230.8)	-9.3	11.2	—	+3000	—	—	RNAV1

INSTRUMENT APPROACH CHART

RJCJ / CHITOSE

VOR/DME NR.1 RWY18L

CHITOSE APP 120.1-124.7 362.3-305.7	CHITOSE VOR/DME 116.9 CHE CH-116X 42°42'00"N/141°41'10"E	CHITOSE TOWER 126.2 - 118.2 236.8-304.5-121.7G	RADAR AVAILABLE
---	---	--	-----------------

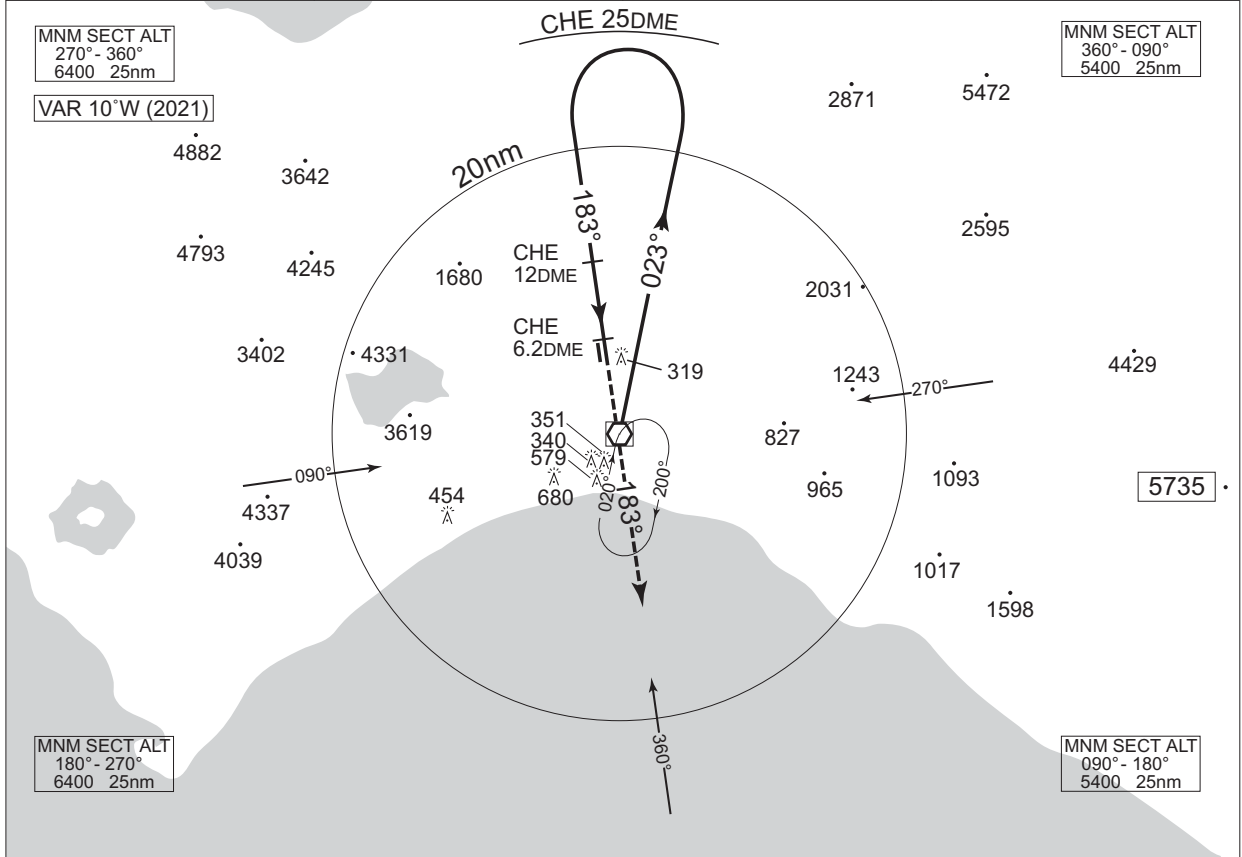

MISSED APPROACH
 At 6.2DME prior to CHE VOR/DME, climb to 4000' (2000' for PROP) on CHE R-183. Contact CHITOSE APP.

Remain within CHE 25DME
 Left turn start at 4000'.

CHANGE : VAR. PROC course.

MINIMA		THR elev. 70	AD elev. 89	
CAT			CIRCLING	
	MDA(H)	RVR/CMV	MDA(H)	VIS
A	560 (490)	1000	620 (531)	1600
B		1200		640 (551)
C			1600	
D				

INSTRUMENT APPROACH CHART

RJCJ / CHITOSE

VOR/DME NR.2 RWY18L

CHITOSE APP 120.1-124.7 362.3-305.7	CHITOSE VOR/DME 116.9 CHE CH-116X 42°42'00"N/141°41'10"E	CHITOSE TOWER 118.2-126.2 236.8-304.5-121.7G	RADAR AVAILABLE
---	---	--	-----------------

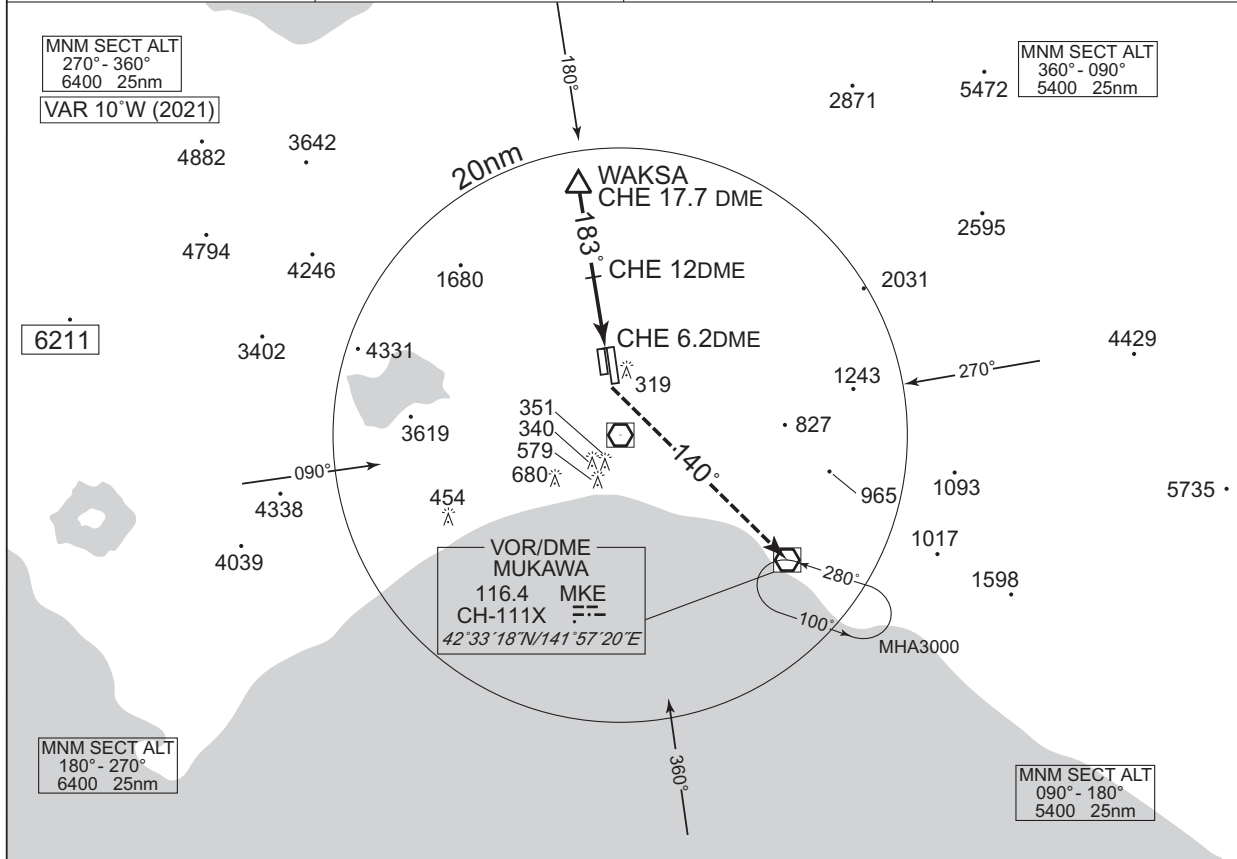

CHANGE : VAR. Course FM WAKSA to CHE 6.2DME.

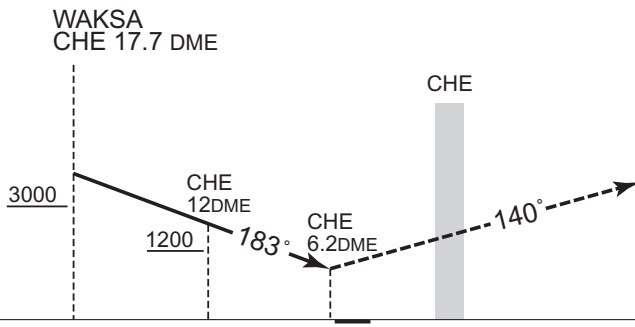

MISSED APPROACH
At 6.2DME prior to CHE VOR/DME, turn left climb via MKE R-320 to 5000' proceed to MKE VOR/DME and hold.
Contact CHITOSE APP.

MINIMA		THR elev. 70	AD elev. 89	
CAT			CIRCLING	
	MDA(H)	RVR/CMV	MDA(H)	VIS
A	560 (490)	1000	620 (531)	1600
B		1200		640 (551)
C			1600	

INSTRUMENT APPROACH CHART

RJCJ / CHITOSE

VOR NR.1 RWY36R

<p>CHITOSE APP 120.1 - 124.7 362.3 - 305.7</p>	<p>CHITOSE VOR/DME 116.9 CHE CH-116X 42°42'00"N/141°41'10"E</p>	<p>CHITOSE TOWER 126.2 - 118.2 236.8 - 304.5 - 121.7G</p>	<p>RADAR AVAILABLE</p>
--	---	---	------------------------

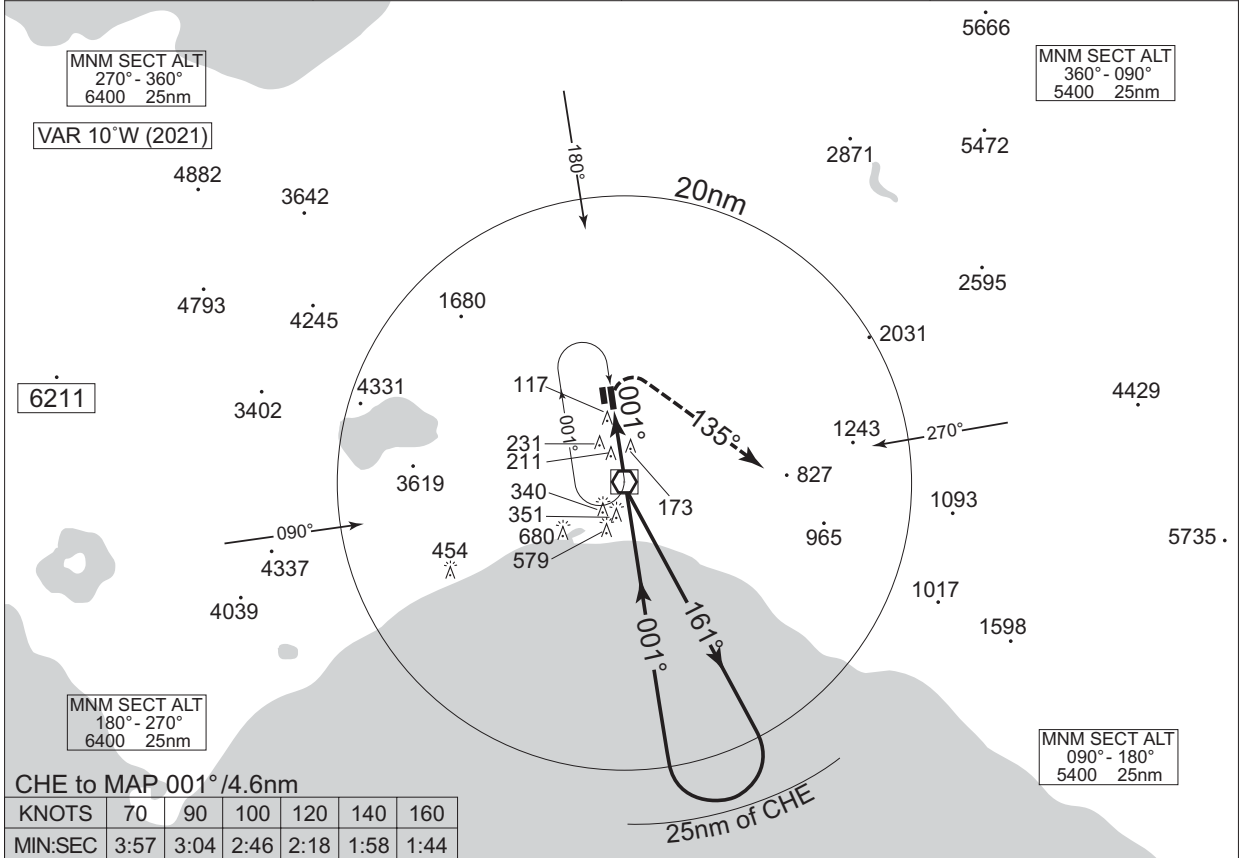

MISSED APPROACH
At 4.6nm after passing CHE VOR, turn right climb to 4000' (2000' for PROP) on 135°. Contact CHITOSE APP.

FL140 7000

Remain within 25nm of CHE right turn start at 6000'.

CAT	MINIMA		THR elev. 85	AD elev. 89
	MDA(H)	RVR/CMV	CIRCLING	
A	620 (531)	1000	620 (531)	1600
B		1200		2400
C		1600	640 (551)	3200
D				

CHANGE : VAR.

INSTRUMENT APPROACH CHART

RJCJ / CHITOSE

VOR NR.2 RWY36R

CHITOSE APP 120.1 - 124.7 362.3 - 305.7	CHITOSE VOR/DME 116.9 CHE CH-116X 42°42'00"N/141°41'10"E	CHITOSE TOWER 118.2 - 126.2 236.8 - 304.5 - 121.7G	RADAR AVAILABLE
---	---	--	-----------------

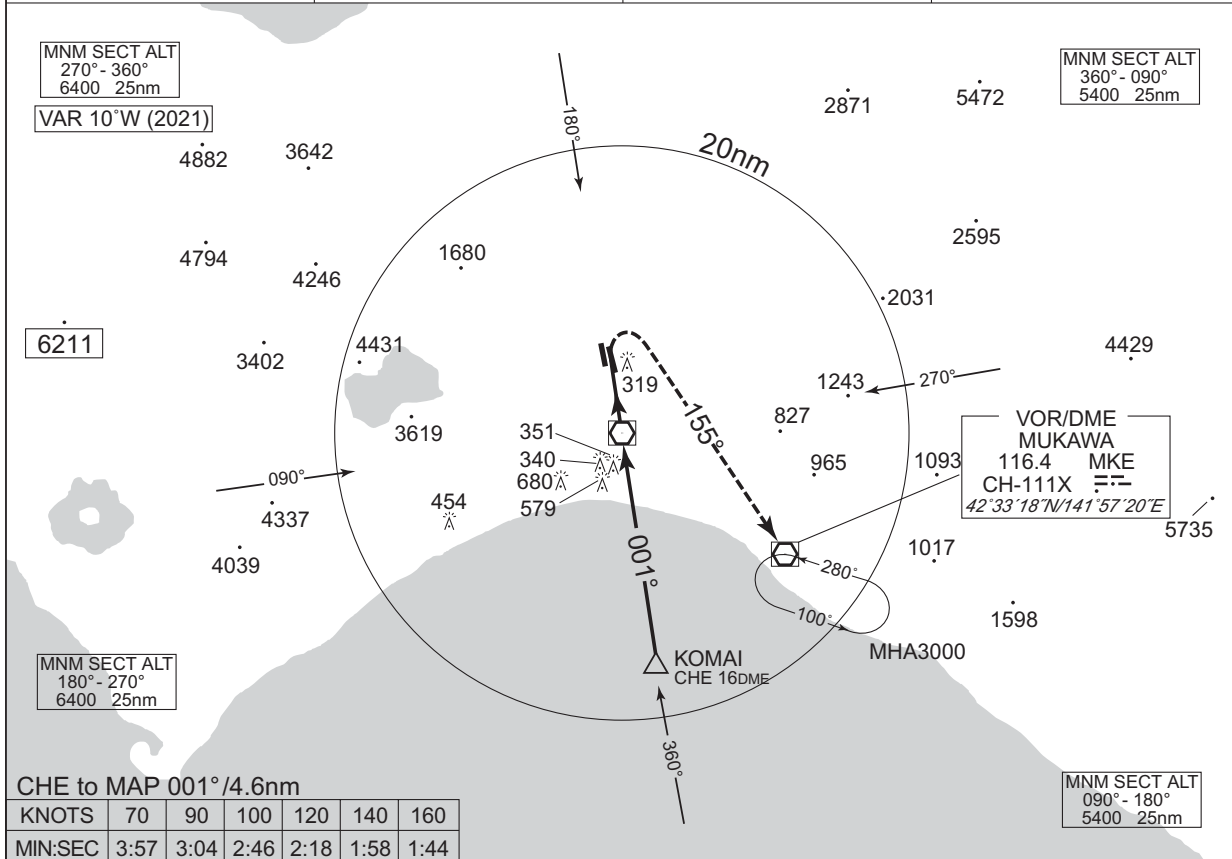

MISSED APPROACH

At 4.6nm after passing CHE VOR,
turn right climb via MKE
R-335 to 5000', proceed to
MKE VOR/DME and hold.
Contact CHITOSE APP.

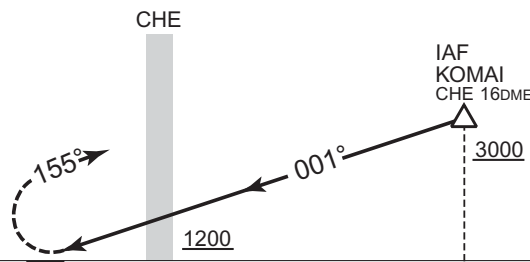

CHANGE : VAR.

CAT	MINIMA		THR elev. 85	AD elev. 89
	MDA(H)	RVR/CMV	CIRCLING	
A	620 (531)	1000	620 (531)	1600
B		1200		2400
C		1600	640 (551)	3200
D				

INSTRUMENT APPROACH CHART

RJCJ / CHITOSE ILS Z RWY 36R

CHITOSE APP 124.7 - 120.1 362.3 - 305.7	ILS - LOC 110.3 ICB $\ddot{\cdot}\ddot{\cdot}\ddot{\cdot}$ ILS-GP 335.0	CHITOSE TOWER 126.2 - 118.2 236.8 - 304.5 - 121.7G	RADAR AVBL
---	---	--	------------

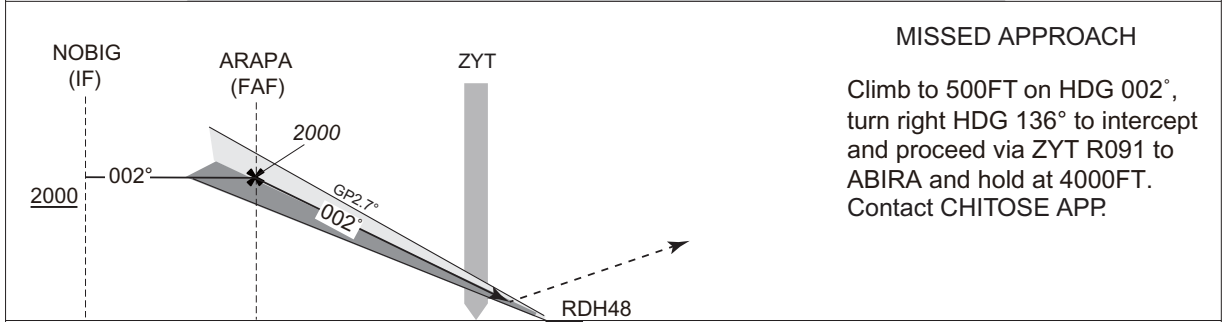
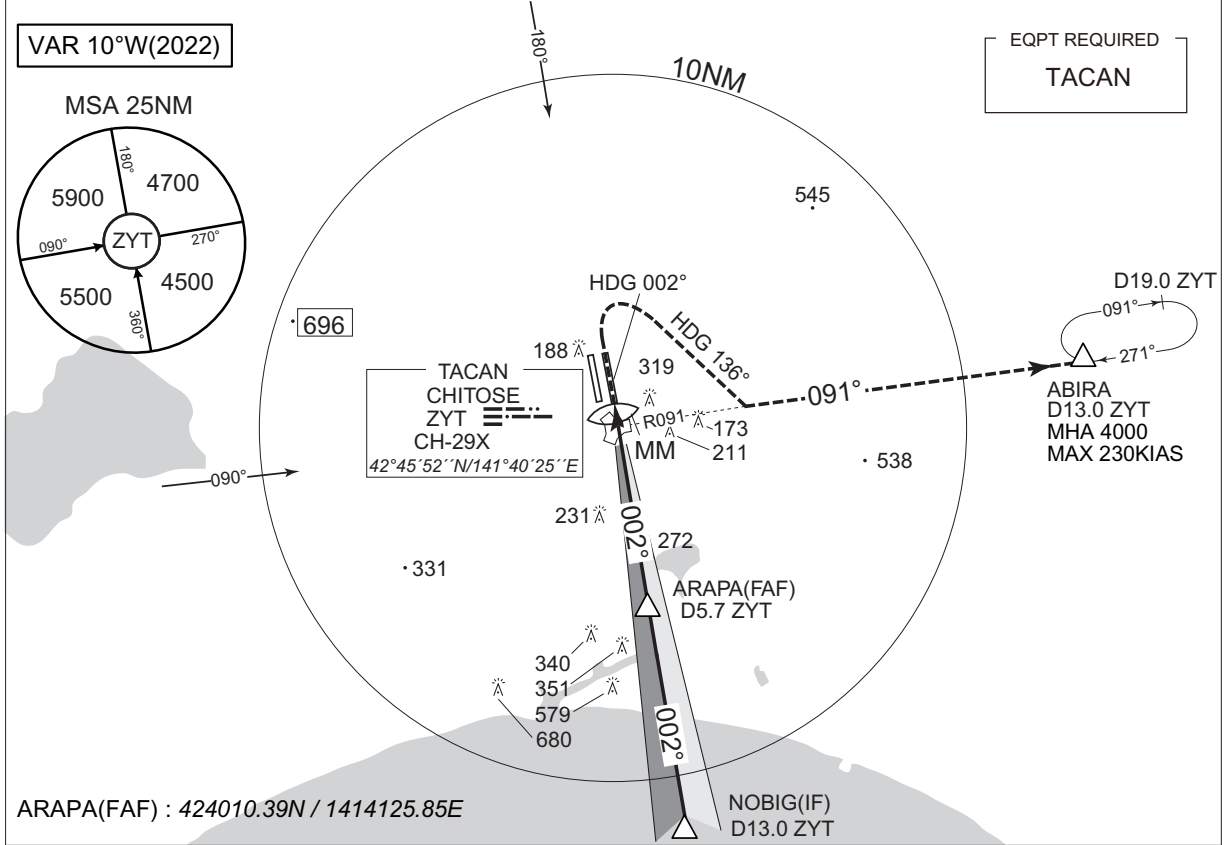

MISSED APPROACH
Climb to 500FT on HDG 002°, turn right HDG 136° to intercept and proceed via ZYT R091 to ABIRA and hold at 4000FT. Contact CHITOSE APP.

13.0	5.7	0.7	0	DME to ZYT
13.7	6.4			NM to THR

Missed APCH climb gradient MNM 4.0%

MINIMA	THR elev. 85	AD elev. 89		
CAT	CAT I		CIRCLING	
	DA(H)	RVR/CMV	MDA(H)	VIS
A	285 (200)	750	620(531)	1600
B				2400
C			660(571)	3200
D				

CHANGE : Circling restriction.

MINIMA with Missed APCH climb gradient of 2.5% are not established.
Circling to RWY18L ONLY.

INSTRUMENT APPROACH CHART

RJCJ / CHITOSE

LOC RWY36R

CHITOSE APP 124.7 - 120.1 362.3 - 305.7	ILS - LOC 110.3 ICB $\ddot{::}::$ ILS-GP 335.0	CHITOSE TOWER 126.2 - 118.2 236.8 - 304.5 - 121.7G	RADAR AVBL
---	--	--	------------

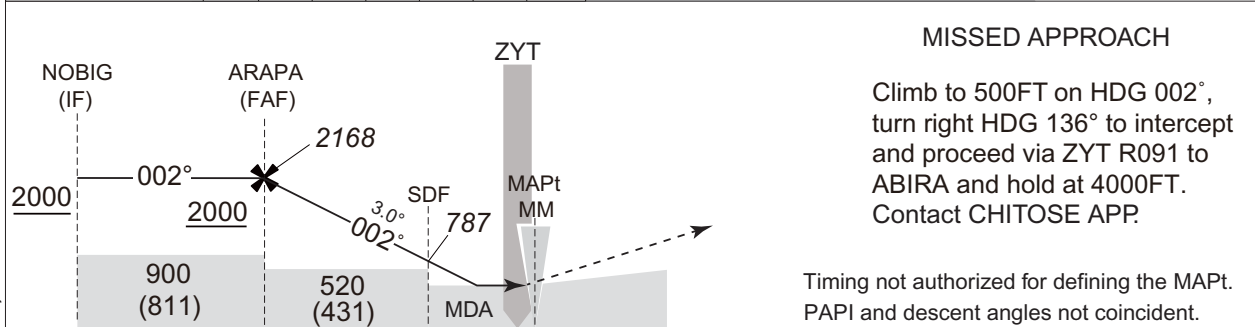
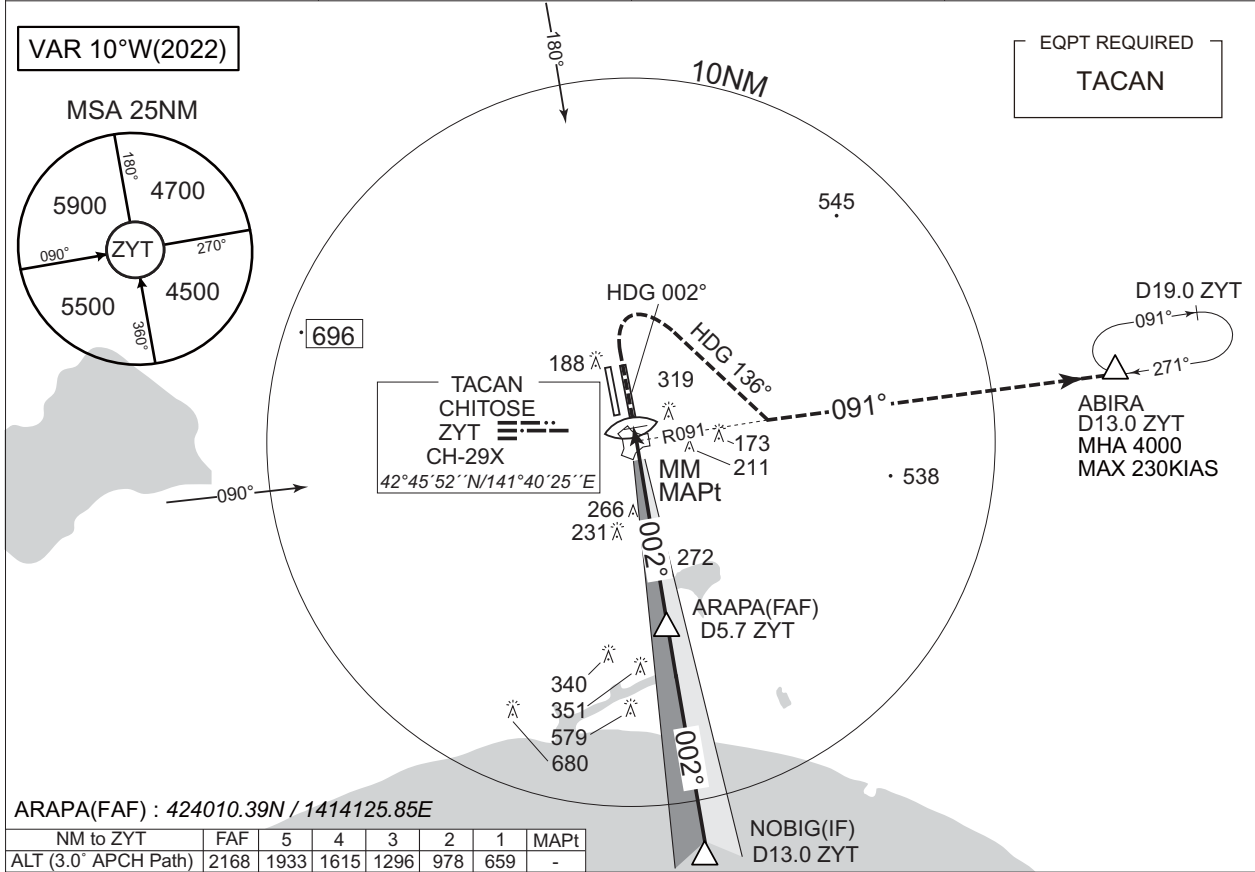

13.0	5.7	1.4	0.1	DME to / from ZYT
13.7	6.4	2.1	0.7 0.6 0	NM to THR

MINIMA		THR elev. 85		AD elev. 89	
CAT	CIRCLING				VIS
	MDA(H)	RVR/CMV	MDA(H)		
A	400 (311)	900	620(531)	1600	
B		1000		660(571)	2400
C			1400		3200
D					

Circling to RWY18L ONLY.

CHANGE : SDF added. OBST added(266).

INSTRUMENT APPROACH CHART

RJCJ / CHITOSE

ILS Y RWY 36R

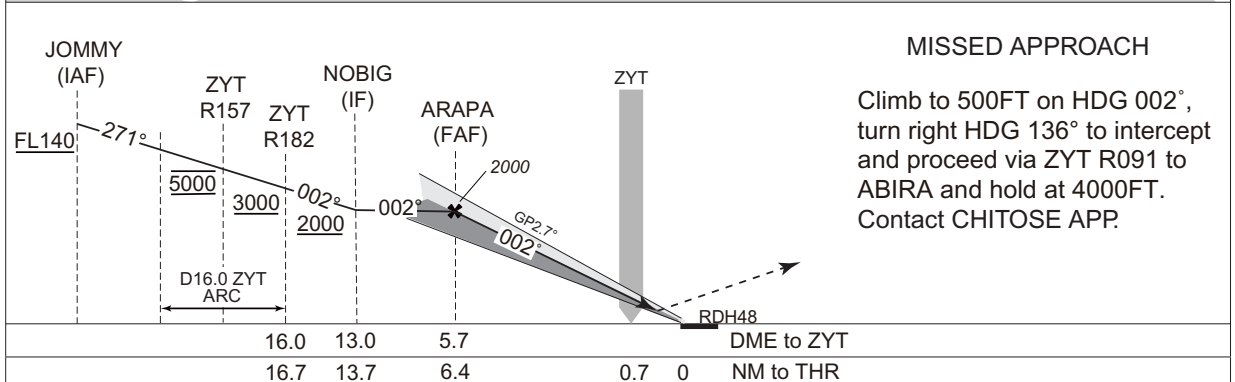
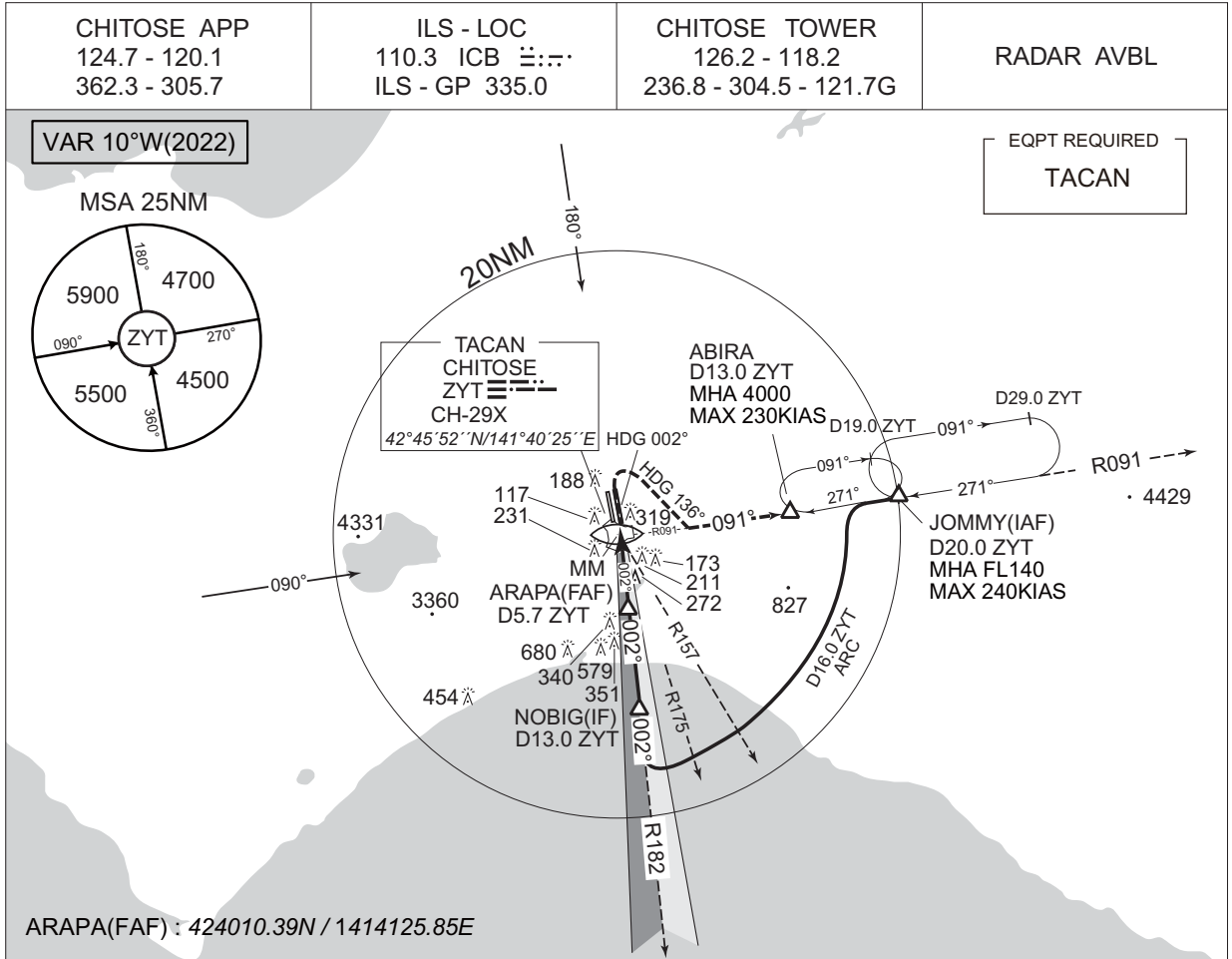

Missed APCH climb gradient MNM 4.0%					
MINIMA		THR elev. 85	AD elev. 89		
CHANGE : Circling restriction.	CAT	CAT I		CIRCLING	
		DA(H)	RVR/CMV	MDA(H) VIS	
	A	285 (200)	750	620(531)	1600
	B				2400
C	660(571)			3200	
D	MINIMA with Missed APCH climb gradient of 2.5% are not established. Circling to RWY18L ONLY.				

INSTRUMENT APPROACH CHART

RJCJ / CHITOSE

ILS X RWY 36R

CHITOSE APP 124.7 - 120.1 362.3 - 305.7	ILS - LOC 110.3 ICB 335.0 ILS - GP 335.0	CHITOSE TOWER 126.2 - 118.2 236.8 - 304.5 - 121.7G	RADAR AVBL
---	--	--	------------

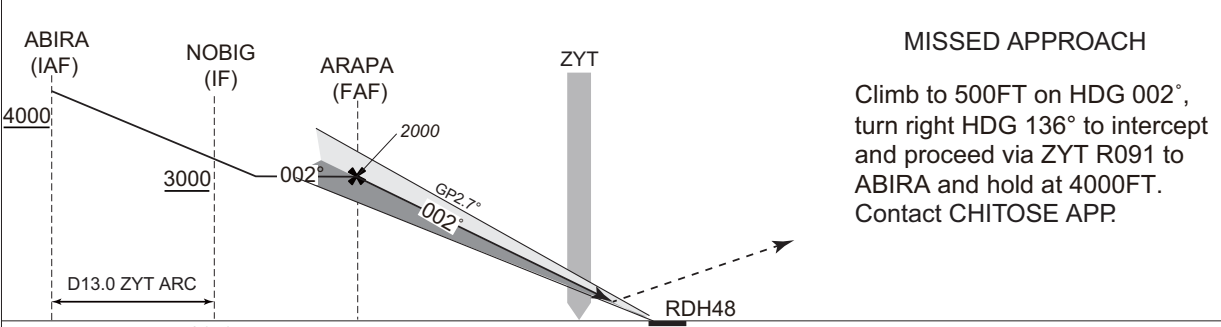
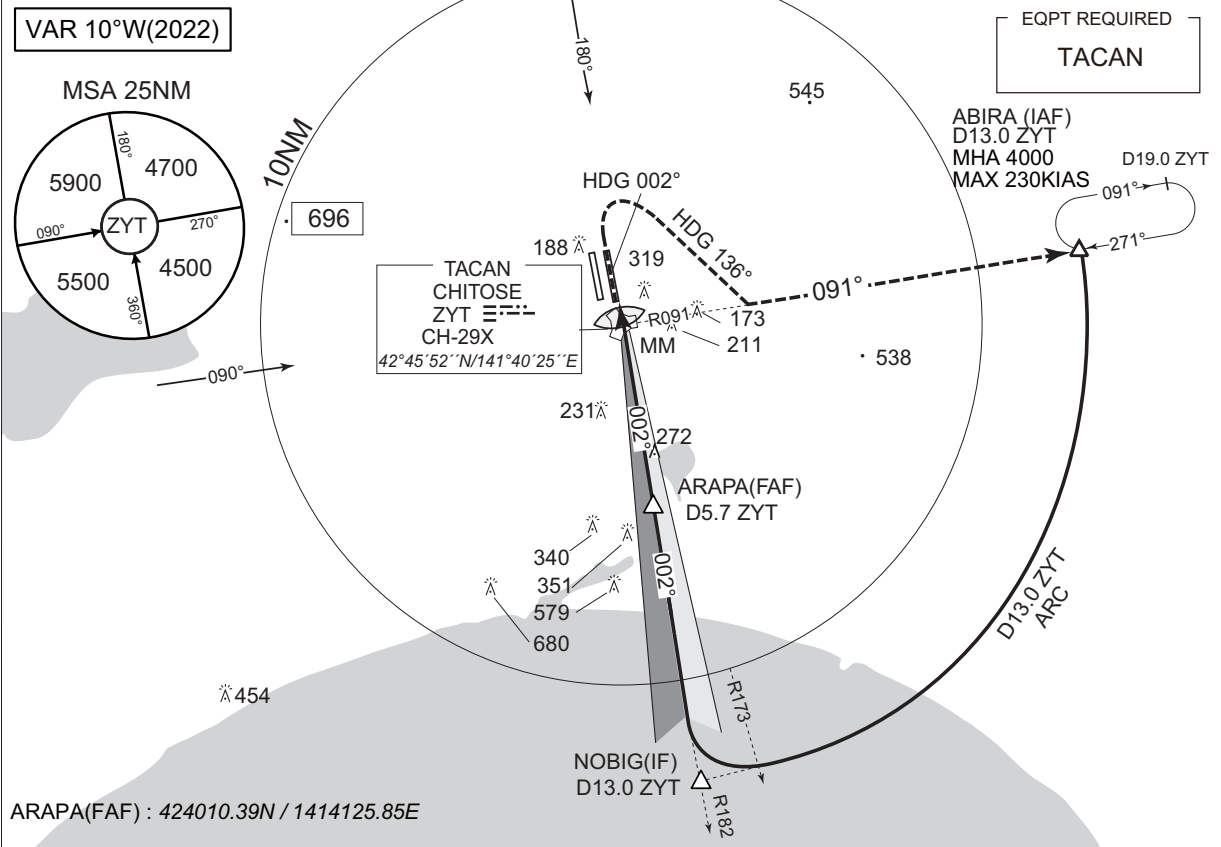

13.0	5.7				DME to ZYT
13.7	6.4	0.7	0		NM to THR

Missed APCH climb gradient MNM 4.0%

CAT	CAT I		CIRCLING	
	DA(H)	RVR/CMV	MDA(H)	VIS
	A	285 (200)	750	620(531)
B	2400			
C	660(571)			3200
D				

MINIMA with Missed APCH climb gradient of 2.5% are not established.
Circling to RWY18L ONLY.

CHANGE : Circling restriction.

INSTRUMENT APPROACH CHART

RJCJ / CHITOSE

TACAN Z RWY 36R

CHITOSE APP 124.7 - 120.1 362.3 - 305.7	CHITOSE TACAN CH-29 ZYT $\equiv \text{---} \text{---}$ 42°45'52"N/141°40'25"E	CHITOSE TOWER 126.2 - 118.2 236.8 - 304.5 - 121.7G	RADAR AVAILABLE
---	---	--	-----------------

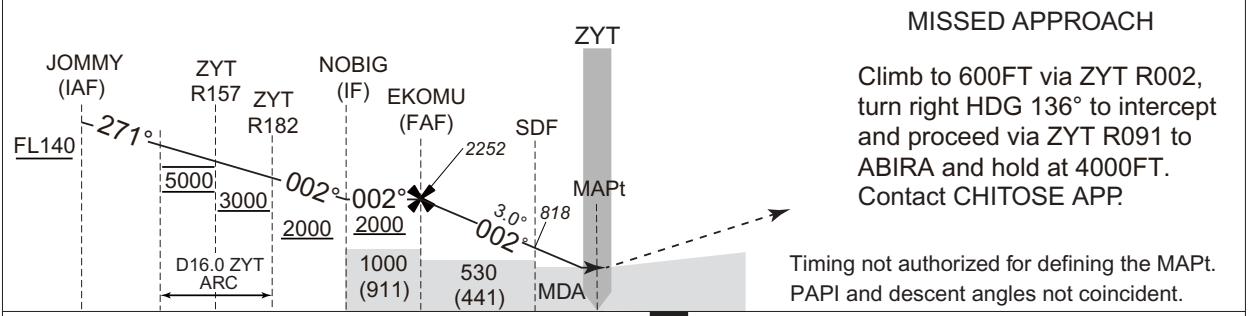
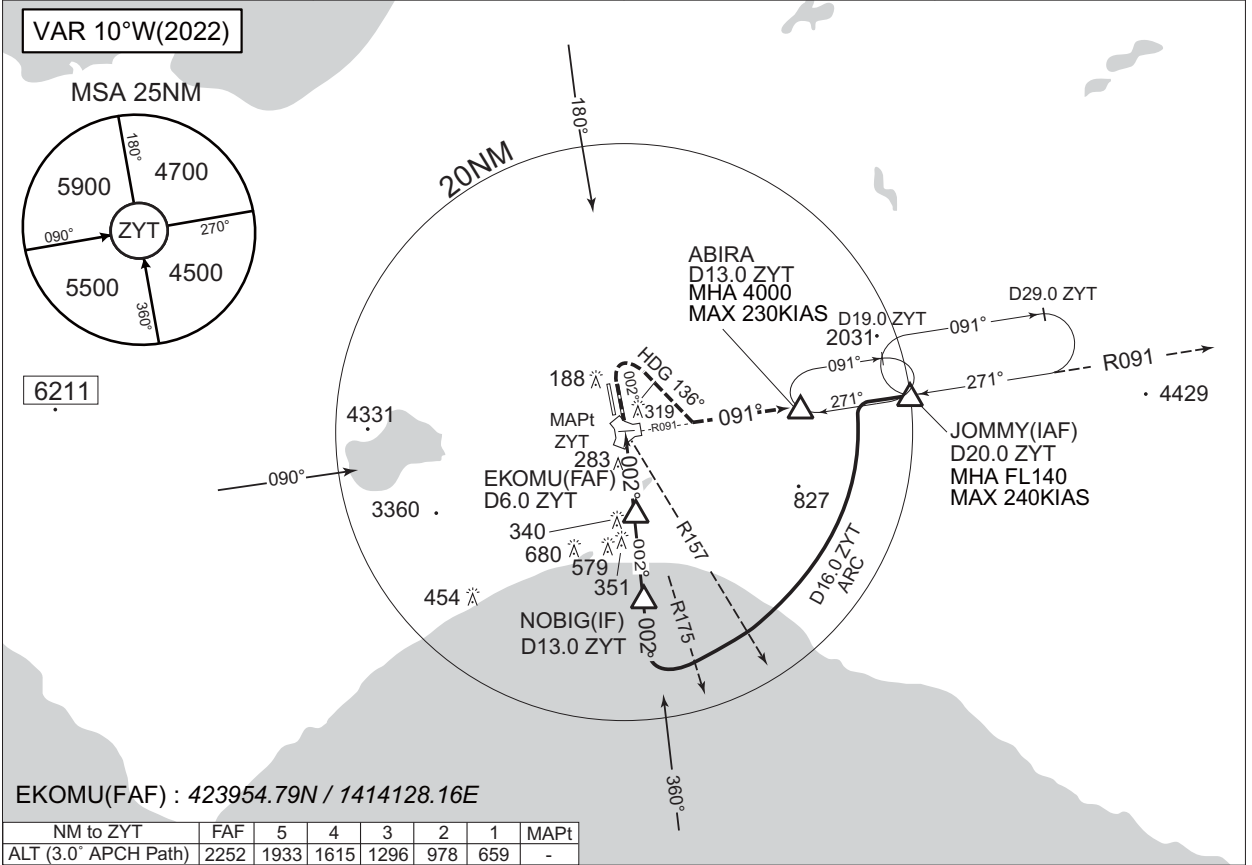

16.0	13.0	6.0	1.5	0.7	0	DME to ZYT
16.7	13.7	6.7	2.2	0.7	0	NM to THR

MINIMA		THR elev. 85	AD elev. 89	
CAT			CIRCLING	
	MDA(H)	RVR/CMV	MDA(H)	VIS
	450(361)	900	620(531)	1600
		1000		2400
D	1400	660(571)	3200	

Circling to RWY18L ONLY.

CHANGE : SDF added. OBST added(283).

INSTRUMENT APPROACH CHART

RJCJ / CHITOSE

TACAN Y RWY 36R

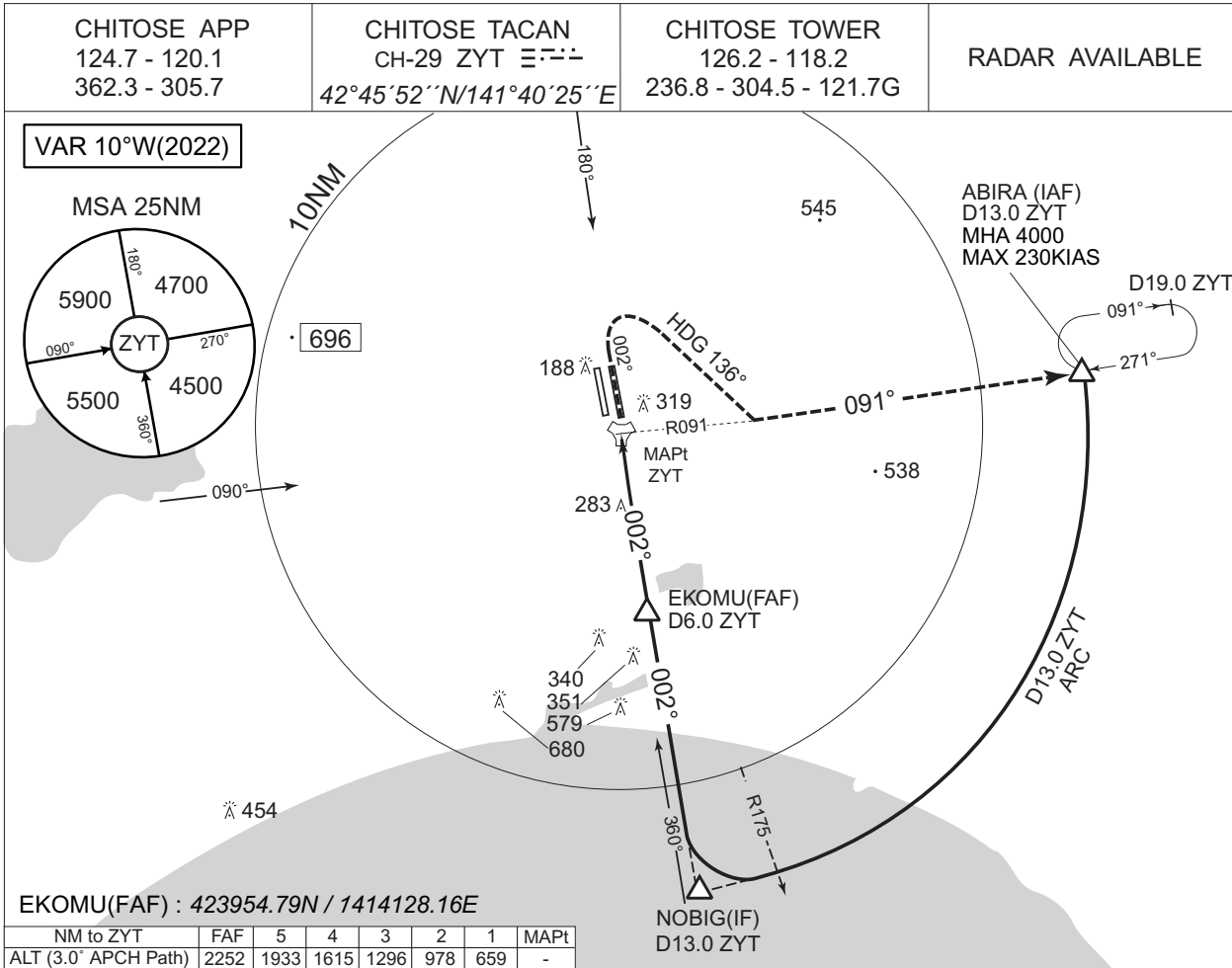

MISSED APPROACH

Climb to 600FT via ZYT R002, turn right HDG 136° to intercept and proceed via ZYT R091 to ABIRA and hold at 4000FT. Contact CHITOSE APP.

Timing not authorized for defining the MAPt. PAPI and descent angles not coincident.

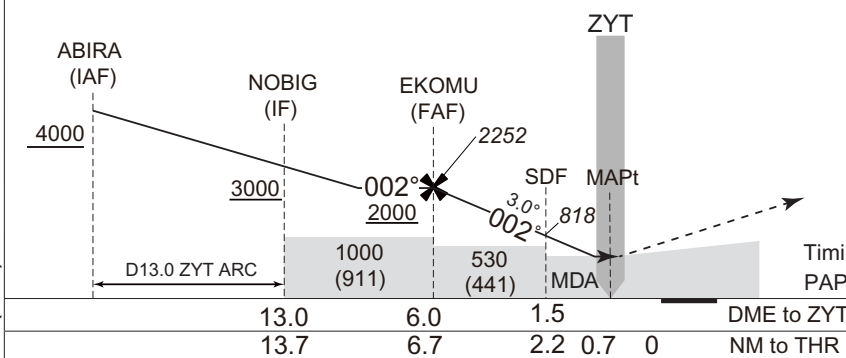

MINIMA		THR elev. 85	AD elev. 89		
CAT			CIRCLING		
	MDA(H)	RVR/CMV	MDA(H)	VIS	
A	450(361)	900	620(531)	1600	
B		1000		660(571)	2400
C			1400		3200
D					

Circling to RWY18L ONLY.

CHANGE : SDF added. OBST added(283).

INSTRUMENT APPROACH CHART

RJCJ / CHITOSE

TACAN Z RWY 18L

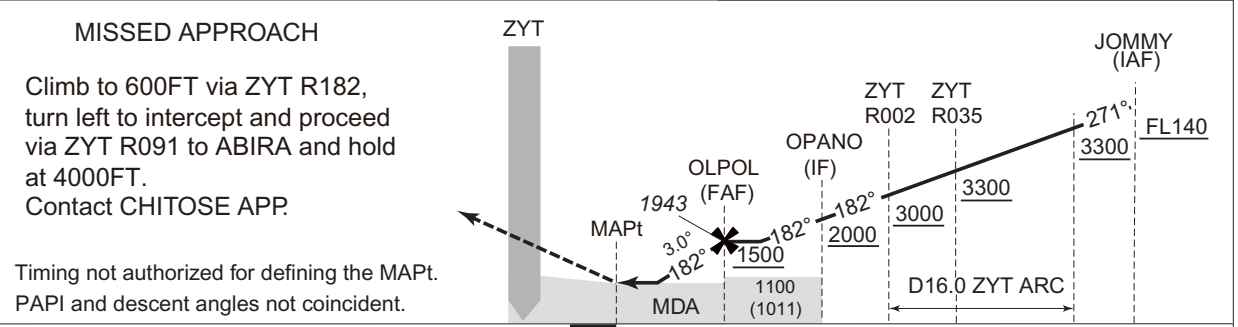
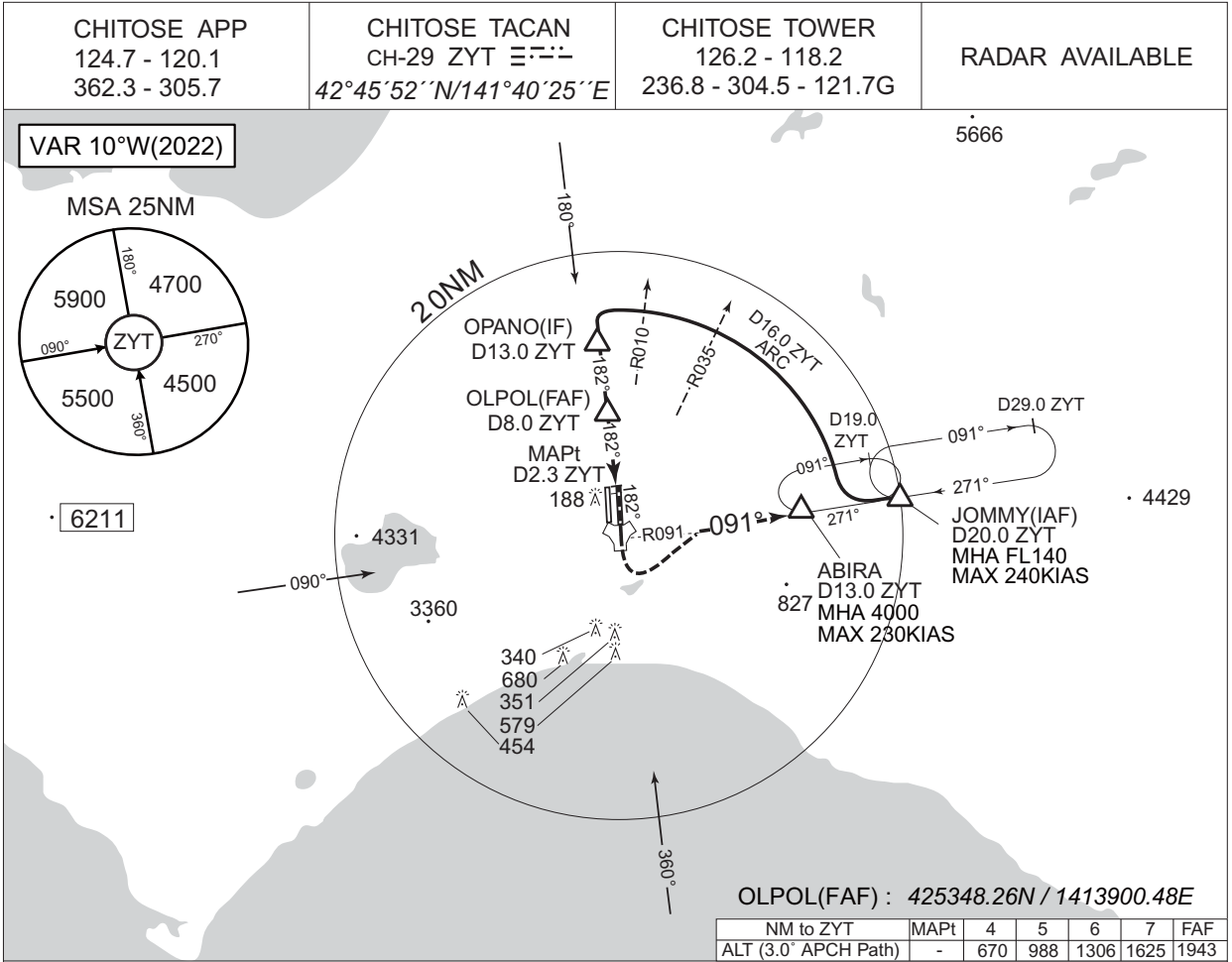

DME to ZYT	2.3	8.0	13.0	16.0
NM to THR	0	5.7	10.7	13.7

MINIMA		THR elev. 70		AD elev. 89		
CAT	CIRCLING		MDA(H)	VIS		
	MDA(H)	RVR/CMV				
A	500(430)	900	620(531)	1600		
B		1000				
C		1400				2400
D		1400				3200

CHANGE : Circling restriction.

Circling to RWY36R ONLY.

INSTRUMENT APPROACH CHART

RJCJ / CHITOSE

TACAN Y RWY 18L

CHITOSE APP 124.7 - 120.1 362.3 - 305.7	CHITOSE TACAN CH-29 ZYT $\equiv \text{---}$ 42°45'52"N/141°40'25"E	CHITOSE TOWER 126.2 - 118.2 236.8 - 304.5 - 121.7G	RADAR AVAILABLE
---	--	--	-----------------

VAR 10°W(2022)

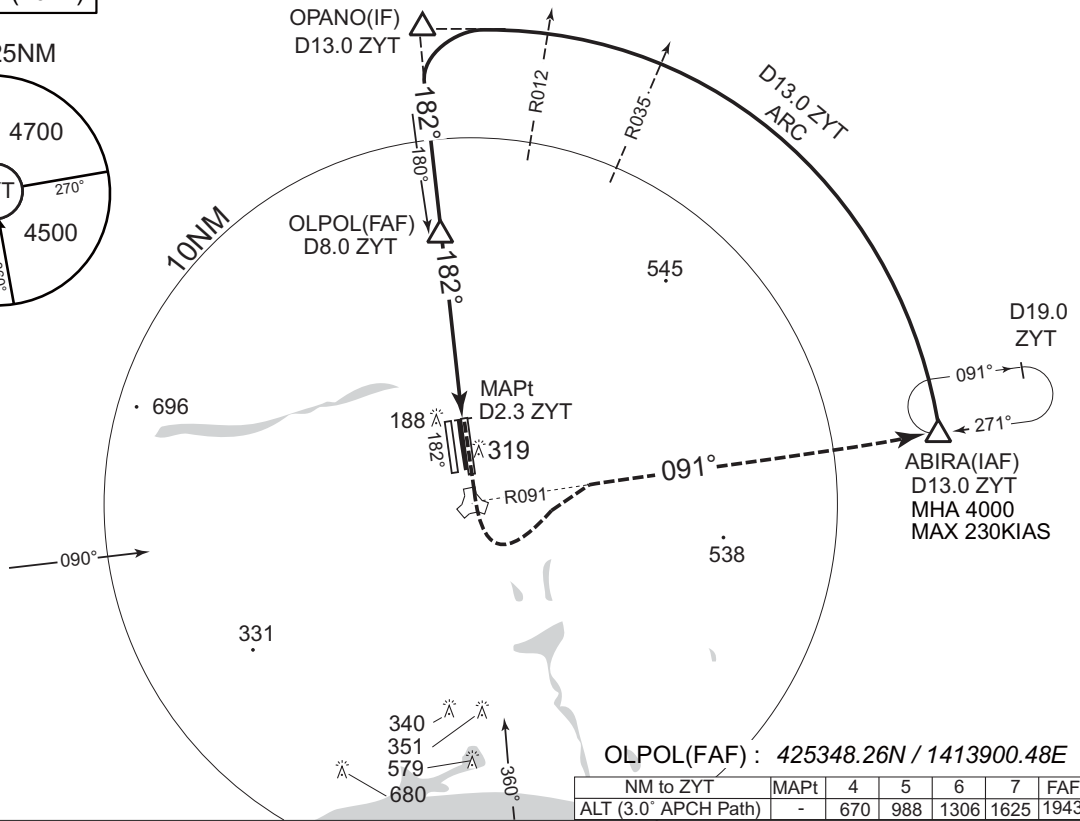
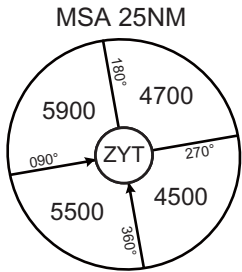

NM to ZYT	MAPt	4	5	6	7	FAF
ALT (3.0° APCH Path)	-	670	988	1306	1625	1943

MISSED APPROACH

Climb to 600FT via ZYT R182, turn left to intercept and proceed via ZYT R091 to ABIRA and hold at 4000FT.
Contact CHITOSE APP.

Timing not authorized for defining the MAPt.
PAPI and descent angles not coincident.

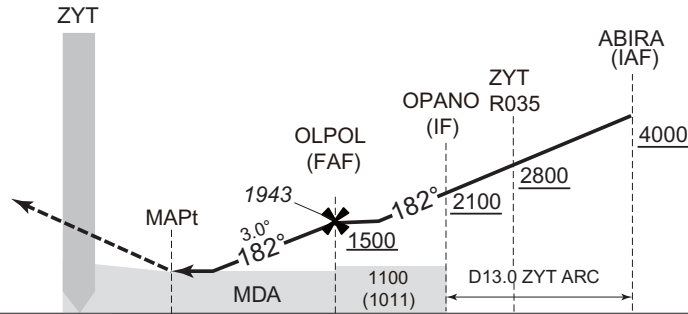

DME to ZYT	2.3	8.0	13.0
NM to THR	0	5.7	10.7

MINIMA		THR elev. 70	AD elev. 89	
CAT	MDA(H)		CIRCLING	
	MDA(H)	RVR/CMV	MDA(H)	VIS
A	500(430)	900	620(531)	1600
B		1000		2400
C		1400	660(571)	3200
D				

Circling to RWY36R ONLY.

CHANGE : Circling restriction.