

**AD 2 AERODROMES**

**RJFK AD 2.1 AERODROME LOCATION INDICATOR AND NAME**

**RJFK - KAGOSHIMA**

**RJFK AD 2.2 AERODROME GEOGRAPHICAL AND ADMINISTRATIVE DATA**

1	ARP coordinates and site at AD	314812N/1304310E 150° / 1.5km from RWY 16 THR
2	Direction and distance from (city)	29.6km (16.0nm) NE of Kagoshima-Chuo railway station. 8.5km(4.6nm) Kajiki Railway station.
3	Elevation/ Reference temperature	891ft / 31°C (2012-2016)
4	Geoid undulation at AD ELEV PSN	Nil
5	MAG VAR/ Annual change	7°W (2022) / 5.4'W
6	AD Administration, address, telephone, telefax, telex, AFS, e-mail and/or Web-site addresses	Kagoshima Airport Office (CAB) Fumoto, Mizobe-cho, Kirishima-shi, Kagoshima Pref. AFS:RJFKYFYX Tel:0995(58)4461
7	Types of traffic permitted (IFR/VFR)	IFR/VFR
8	Remarks	Nil

**RJFK AD 2.3 OPERATIONAL HOURS**

1	AD Administration	2200 - 1300
2	Customs and immigration	Customs: 2330-0815 Immigration: INTL SKED FLT hours only
3	Health and sanitation	Quarantine(human): 2330-0815 Quarantine(animal, plant): INTL SKED FLT hours only
4	AIS Briefing Office	H24
5	ATS Reporting Office(ARO)	Nil
6	MET Briefing Office	H24(FUKUOKA)
7	ATS	2200 - 1300 (Flight Information Service (except ATIS) and Alerting Service : H24)
8	Fuelling	2330 - 0800
9	Handling	2200 - 1300
10	Security	2105 - 1210
11	De-icing	Nil
12	Remarks	Nil

**RJFK AD 2.4 HANDLING SERVICES AND FACILITIES**

1	Cargo-handling facilities	No limitation
2	Fuel/ oil types	Fuel / JET A-1, AVGAS 100 Oil / W80,W100
3	Fuelling facilities/ capacity	Fuel Truck Refueling, No limitation
4	De-icing facilities	Nil
5	Hangar space for visiting aircraft	Nil
6	Repair facilities for visiting aircraft	Nil
7	Remarks	Nil

**RJFK AD 2.5 PASSENGER FACILITIES**

1	Hotels	Hotels in the city
2	Restaurants	At Airport, Not Continuous
3	Transportation	Busses and Taxis
4	Medical facilities	Hospital in Kajiki-cho (10km from Airport)
5	Bank and Post Office	At Airport, Not Continuous
6	Tourist Office	Nil
7	Remarks	Nil

**RJFK AD 2.6 RESCUE AND FIRE FIGHTING SERVICES**

1	AD category for fire fighting	CAT 9
2	Rescue equipment	Chemical fire fighting truck, Water-supply truck, Lighting power supply truck, Emergency medical equipments conveyance truck
3	Capability for removal of disabled aircraft	Nil
4	Remarks	Nil

**RJFK AD 2.7 SEASONAL AVAILABILITY-CLEARING**

1	Types of clearing equipment	Snow removal equipment: Motor grader x 5, Tractor shovel x 1, Truck x 1, Sweeper x 1
2	Clearance priorities	(1)RWY16/34, TWY(T1, T8, P1-P6) (2)TWY(T2-T7), APN
3	Remarks	Seasonal availability : From DEC 1st to MAR 31st, Snow removal will be commenced, if the RWY are covered with a depth of 3cm snow or more.

**RJFK AD 2.8 APRONS, TAXIWAYS AND CHECK LOCATIONS DATA**

1	Apron surface and strength	Surface-Asphalt concrete, and concrete in part Strength: PCN 62/R/B/X/T PCN 20/F/A/Y/T PCN 20/R/B/X/T in front of Japan Coast Guard hangar
2	Taxiway width, surface and strength	Surface: Asphalt concrete Strength: PCN 58/F/A/X/T Width: 23m (P1-P6), 28.5m (T1, T7, T8), 34m (T2, T3, T4 and T6), 30m (T5)
3	ACL and elevation	Not available
4	VOR checkpoints	Not available
5	INS checkpoints	(Spot NR)  1 : 314817.13N, 1304251.30E 2 : 314815.26N, 1304252.50E 3 : 314813.42N, 1304253.74E 4 : 314811.39N, 1304255.12E 5 : 314809.37N, 1304256.54E 6 : 314807.42N, 1304257.91E 7 : 314805.92N, 1304259.23E 8 : 314804.66N, 1304300.08E 9 : 314803.04N, 1304300.76E 10 : 314801.16N, 1304302.04E 17 : 314749.18N, 1304310.21E 18 : 314747.22N, 1304311.53E
6	Remarks	Nil

**RJFK AD 2.9 SURFACE MOVEMENT GUIDANCE AND CONTROL SYSTEM AND MARKINGS**

1	Use of aircraft stand ID signs, TWY guide lines and Visual docking/ parking guidance system of aircraft stands	ACFT stand ID sign: NR 3 - 10
2	RWY and TWY markings and LGT	RWY: (RWY 16/34) (Marking): RWY designation, RWY CL, RWY THR, Aiming point, TDZ, RWY side stripe (LGT):REDL, RENL, RCLL, RTHL, RTZL(RWY 34), WBAR(RWY34) RWY DIST marker LGT  TWY: ALL TWY (Marking): TWY CL, TWY side stripe (LGT): TWY edge LGT, TWY CL LGT  TWY: T1 - T8 (Marking): RWY HLDG PSN, Mandatory instruction (LGT): RWY guard LGT, Taxiing guidance sign
3	Stop bars	Stop bar LGT : T1-T6, T8 Stop bar LGT operations 1)Stop bar LGT are installed at each RWY holding position associated with RWY 16/34. 2)Stop bar LGT will be operated when the visibility or the lowest RVR of RWY 16/34 is at or less than 600m. 3)Stop bar LGT on TWY T1,T8 are controlled individually by ATC. 4)Stop bar LGT on TWY T2 through T6 are not controlled individually by ATC. 5)During the period Stop bar LGT operated, TWY T2 through T7 are not available for departure aircraft.
4	Remarks	(Marking): Overrun area (LGT) Apron flood LGT



**RJFK AD 2.10 AERODROME OBSTACLES**

In approach/TKOF areas

See AD 2.24 Obstacle Chart

RWY/Area affected	Obstacle type	Coordinates	Elevation	Markings/LGT	Remarks
	Pylon	315718N1303639E	2117ft	Marking / -	Above outer horizontal surface
	Pylon	315717N1303651E	2189ft	Marking / Lighted	Above outer horizontal surface
	Pylon	315716N1303704E	1894ft	Marking / -	Above outer horizontal surface
	Building	314939N1304110E	1245ft	- / Lighted	Above conical surface
	Pylon	315227N1304736E	1627ft	Marking / Lighted	Above conical surface
	Windmill	314038N1303551E	1903ft	Marking / Lighted	Above outer horizontal surface
	Windmill	314034N1303547E	1903ft	- / Lighted	Above outer horizontal surface
	Windmill	314030N1303542E	1913ft	- / Lighted	Above outer horizontal surface
	Windmill	314025N1303550E	2015ft	Marking / Lighted	Above outer horizontal surface
	Windmill	314019N1303548E	2070ft	Marking / Lighted	Above outer horizontal surface
	Windmill	314013N1303548E	2067ft	- / Lighted	Above outer horizontal surface
	Windmill	314011N1303554E	2031ft	- / Lighted	Above outer horizontal surface
	Windmill	314006N1303556E	1992ft	Marking / Lighted	Above outer horizontal surface
	Antenna	314925N1304104E	1245ft	Marking / -	Above conical surface
	Antenna	315306N1304841E	1667ft	Marking / Lighted	Above conical surface
	Pylon	315520N1303908E	1794ft	- / Lighted	Above conical surface
	Pylon	315513N1303901E	1840ft	- / Lighted	Above conical surface
	Pylon	315504N1303853E	1803ft	- / -	Above conical surface
	Pylon	315305N1303806E	1678ft	- / Lighted	Above conical surface
	Pylon	315218N1303711E	1638ft	- / Lighted	Above conical surface
	Pylon	315209N1303703E	1849ft	- / Lighted	Above conical surface
	Pylon	315200N1303659E	1938ft	- / Lighted	Above conical surface
	Pylon	315150N1303701E	1725ft	- / Lighted	Above conical surface
	Pylon	315142N1303659E	1678ft	- / -	Above conical surface
	Windmill	313645N1304913E	2063ft	Marking / Lighted	Above outer horizontal surface
	Windmill	313635N1304917E	2119ft	Marking / Lighted	Above outer horizontal surface
	Windmill	313627N1304921E	2210ft	Marking / Lighted	Above outer horizontal surface

In circling area and at AD

Obstacle type	Coordinates	Elevation	Markings/LGT	Remarks
See AD 2.24 Obstacle Chart				

**RJFK AD 2.11 METEOROLOGICAL INFORMATION PROVIDED**

1	Associated MET Office	FUKUOKA
2	Hours of service MET Office outside hours	H24(FUKUOKA)
3	Office responsible for TAF preparation Periods of validity	FUKUOKA 30 Hours
4	Trend forecast Interval of issuance	Nil
5	Briefing/ consultation provided	Briefing is available upon inquiry at FUKUOKA
6	Flight documentation Language(s) used	C En
7	Charts and other information available for briefing or consultation	S <sub>6</sub> , U <sub>85</sub> , U <sub>7</sub> , U <sub>5</sub> , U <sub>3</sub> , U <sub>25</sub> , U <sub>2</sub> /Tr, P <sub>s</sub> , P <sub>5</sub> , P <sub>3</sub> , P <sub>25</sub> , P <sub>SWE</sub> , P <sub>SWF</sub> , P <sub>SWG</sub> , P <sub>SWI</sub> , P <sub>SWM</sub> , P <sub>SW</sub> (domestic), E, C, W <sub>E</sub> , W <sub>F</sub> , W <sub>G</sub> , W <sub>I</sub> , W, N
8	Supplementary equipment available for providing information	Doppler Radar for Airport Weather (See attached chart)
9	ATS units provided with information	TWR, APP, ATIS
10	Additional information (limitation of service, etc.)	Nil

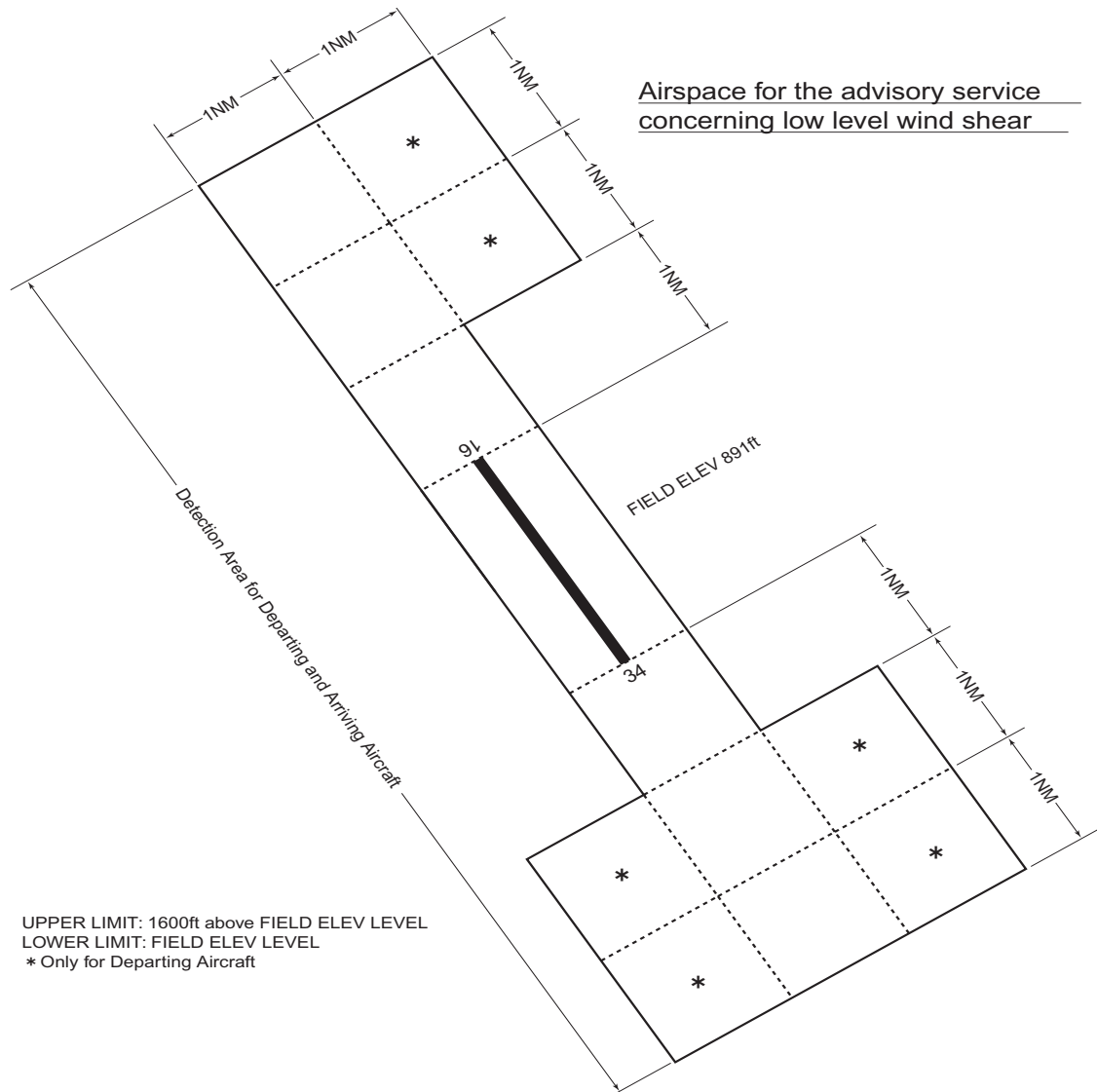

**RJFK AD 2.12 RUNWAY PHYSICAL CHARACTERISTICS**

Designations RWY NR	TRUE BRG	Dimensions of RWY(M)	Strength(PCN) and surface of RWY	THR coordinates THR geoid undulation	THR elevation and highest elevation of TDZ of precision APP RWY
1	2	3	4	5	6
16	150°	3000 x 45	PCN 58/F/A/X/T Asphalt Concrete	314854.41N 1304241.34E	THR ELEV: 906ft TDZ ELEV: 905.2ft
34	330°	3000 x 45	PCN 58/F/A/X/T Asphalt Concrete	314730.07N 1304338.38E	THR ELEV: 858.8ft TDZ ELEV: 861.6ft

Slope of RWY	Strip Dimensions(M)	RESA (Overrun) Dimensions(M)	Remarks
7	10	11	14
See attached chart	3120x 300	240 x (MNM:90 MAX:300)*	RWY grooving 3000 X 30m
See attached chart	3120x 300	240 x (MNM:90 MAX:300)* *For detail, ask airport administrator	RWY grooving 3000 X 30m

**RWY16**      **RWY34**

906.2ft      897.3ft      885.2ft      870.7ft      858.8ft

-0.21%      -0.54%      -0.71%      -0.72%

0m      1200m      1875m      2500m      3000m

**RJFK AD 2.13 DECLARED DISTANCES**

RWY Designator	TORA (m)	TODA (m)	LDA (m)	ASDA (m)	Remarks
1	2	3	4	5	6
16	3000	3000	3000	3000	Nil
34	3000	3000	3000	3000	Nil

**RJFK AD 2.14 APPROACH AND RUNWAY LIGHTING**

RWY Designator	APCH LGT type LEN INTST	RTHL Color WBAR	PAPI (VASIS) Angle DIST FM THR MEHT	RTZL LEN	RCLL LEN Spacing Color INTST	REDL LEN Spacing Color INTST	RENL Color WBAR	STWL LEN Color
1	2	3	4	5	6	7	8	9
16	SALS (*1) 421m LIH	Green -	PAPI 3.0°/LEFT 481m 74ft		3000m 30m Coded color (White/Red) LIH	3000m 60m Coded color (White/Yellow) LIH	Red	Nil (*2)
34	PALS 900m LIH	Green Green	PAPI 3.0°/LEFT 378m 68ft	900m	3000m 30m Coded color (White/Red) LIH	3000m 60m Coded color (White/Yellow) LIH	Red	Nil (*2)
Remarks								
10								
SALS with APCH LGT beacon(561m and 948m FM RWY THR)(*1) Overrun area edge LGT(Color:Red)(*2) CGL for RWY 16								

**RJFK AD 2.15 OTHER LIGHTING, SECONDARY POWER SUPPLY**

1	ABN/IBN location, characteristics and hours of operation	ABN: 314804N/1304328E, White/Green EV4.3sec, HO
2	LDI location and LGT Anemometer location and LGT	LDI: Nil Anemometer : RWY 16: 425m from RWY 16 THR, LGTD RWY 34: 435m from RWY 34 THR, LGTD
3	TWY edge and center line lighting	TWY edge and center line lights installed, see AD2.9
4	Secondary power supply/ switch-over time	Within 1sec: REDL, RENL, RTHL, WBAR, RCLL, Overrun area edge LGT, Stop bar LGT Within 15sec: Other LGT
5	Remarks	WDI LGT

**RJFK AD 2.16 HELICOPTER LANDING AREA**

Nil
-----

RJFK AD 2.17 ATS AIRSPACE

Designation and lateral limits		Vertical limits (ft)	Airspace classification	ATS unit call sign Language	Remarks
1		2	3	4	6
KAGOSHIMA CTR	Area within a radius of 5 nm of KAGOSHIMA ARP (31° 48'N 130° 43'E)	3 000 or below	D	KAGOSHIMA TWR En	
KAGOSHIMA PCA	See attached chart		C	KAGOSHIMA APP(1) KAGOSHIMA RADAR(1) KAGOSHIMA TWR(2) En	(1)Primary (2)Secondary
KAGOSHIMA ACA	See attached chart		E	KAGOSHIMA APP KAGOSHIMA RADAR KAGOSHIMA DEP En	
KAGOSHIMA TCA	See attached chart		E	KAGOSHIMA TCA En	



鹿児島特別管制区  
Kagoshima Positive Control Area

NAME	LATERAL LIMITS	UPPER LIMIT (AMSL)	UNIT PROVIDING SERVICE	REMARKS
		LOWER LIMIT (AMSL) M(ft)		
1	2	3	4	5
鹿児島 KAGOSHIMA	下記に示される区域 The area shown below		Primary Kagoshima APP Kagoshima Radar 126.0 120.8 261.2 Secondary Kagoshima TWR 118.2 126.2 261.2	当該空域を飛行しようとする航空機は、鹿児島アプローチ（鹿児島レーダー）又は鹿児島タワーに連絡し、コールサイン、現在位置、高度及び意図を通報し指示を受けること。 Pilot requiring transit of Kagoshima Positive Control Area must call Kagoshima Approach (Kagoshima Radar) or Kagoshima Tower prior to the point of entry to provide aircraft identification, position, altitude and intention.

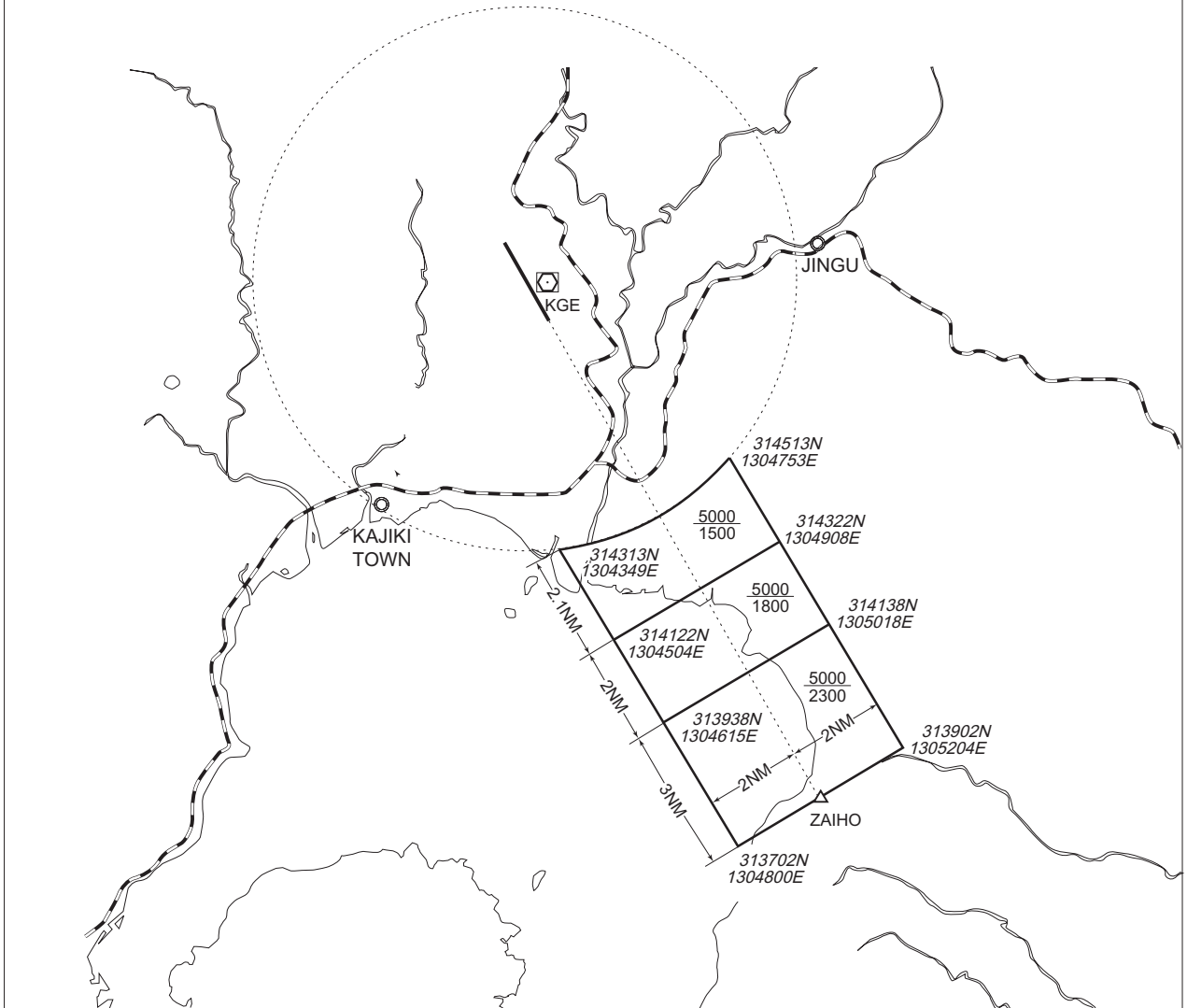

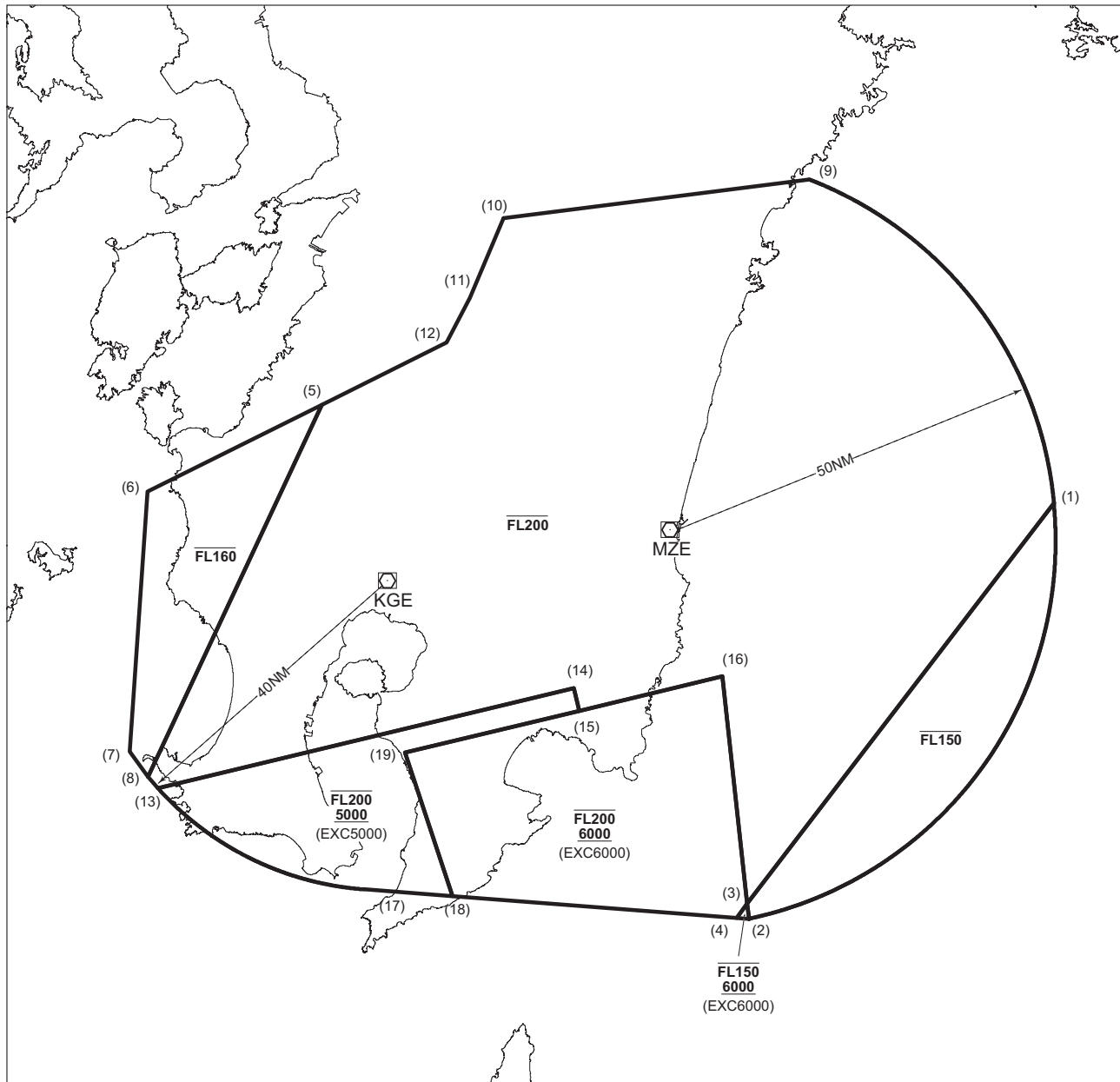
鹿兒島進入管制区  
Kagoshima Approach Control Area

## Point list

(1) 315637N1322447E	(11) 322421N1305624E
(2) 310334N1313731E	(12) 321836N1305245E
(3) 310532N1313718E	(13) 312105N1300842E
(4) 310343N1313539E	(14) 313341N1311133E
(5) 321040N1303343E	(15) 313045N1311220E
(6) 315929N1300708E	(16) 313500N1313405E
(7) 312550N1300425E	(17) 310754N1303942E
(8) 312235N1300712E	(18) 310657N1305257E
(9) 323907N1314828E	(19) 312533N1304601E
(10) 323437N1310137E	

鹿児島ターミナルコントロールエリア  
Kagoshima Terminal Control Area

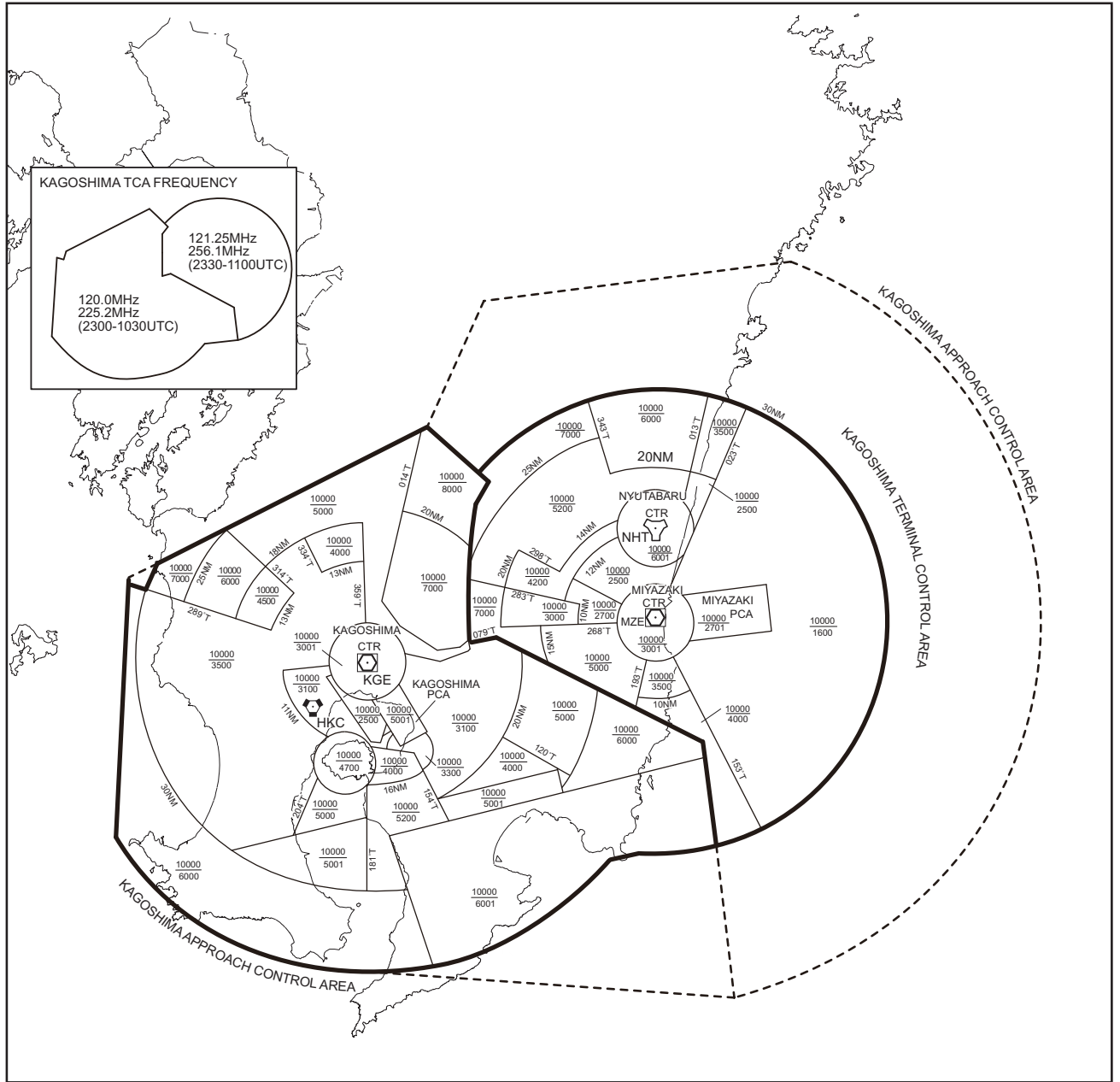

## RJFK AD 2.18 ATS COMMUNICATION FACILITIES

Service designation	Call sign	Frequency	Hours of operation	Remarks
1	2	3	4	5
APP	Kagoshima approach	126.0MHz(1) 119.4MHz 121.4MHz 120.9MHz 362.3MHz 261.2MHz 121.5MHz(E) 243.0MHz(E)	2200 - 1300	(1)Primary
ASR	Kagoshima Radar	120.8MHz 121.4MHz 120.9MHz 362.3MHz 261.2MHz 121.5MHz(E) 243.0MHz(E)	2200 - 1300	
DEP	Kagoshima Departure	119.4MHz(1) 120.1MHz 121.4MHz 362.3MHz 261.2MHz 121.5MHz(E) 243.0MHz(E)	2200 - 1300	
TCA	Kagoshima TCA	120.0MHz 225.2MHz	2300 - 1030	
		121.25MHz 256.1MHz	2330 - 1100	
TWR	Kagoshima Tower	118.2MHz(1) 126.2MHz 261.2MHz 121.5MHz(E) 243.0MHz(E)	2200 - 1300	
GND	Kagoshima Ground	121.7MHz	2200 - 1300	
DLVRY	Kagoshima Delivery	121.8MHz	2200 - 1300	
ATIS	Kagoshima Airport	127.05MHz	2200 - 1300	

RJFK AD 2.19 RADIO NAVIGATION AND LANDING AIDS

Type of aid (VOR declination)	ID	Frequency	Hours of operation	Position of transmitting antenna coordinates	Elevation of DME transmitting antenna	Remarks
1	2	3	4	5	6	7
VOR (7°W/2021)	HKC	113.3MHz	H24	314150.00N/ 1303458.59E		VOR Unusable: 150°-160° beyond 25nm BLW 7000ft.
TACAN	HKC	1167MHz (CH-80X)	H24	314149.80N/ 1303500.26E	1906ft	TACAN DME Unusable: 150°-160° beyond 35nm BLW 7000ft.  TACAN AZM Unusable: 050°-060° beyond 30nm BLW 8000ft. 060°-070° beyond 35nm BLW 8000ft. 150°-160° beyond 20nm BLW 7000ft.
VOR (7°W/2018)	KGE	115.7MHz	2200 - 1300	314751.15N/ 1304333.97E		VOR Unusable : 040°- 070° beyond 20nm BLW 8000ft.
DME	KGE	1191MHz (CH-104X)	2200 - 1300	314751.15N/ 1304333.97E	901ft	DME Unusable : 040°- 050° beyond 15nm BLW 8000ft. 050°- 070° beyond 20nm BLW 8000ft.
ILS-LOC 34	IKG	111.7MHz	2200 - 1300	314900.89N/ 1304236.96E		LOC : 230m(755ft) away FM RWY 16 THR, BRG (MAG) 337°
ILS-GP 34	-	333.5MHz	2200 - 1300	314740.78N/ 1304336.38E		GP : 312m(1024ft) inside FM RWY 34 THR, 120m(394ft) E of RCL. HGT of ILS REF datum 17.3m(57ft). GP angle 3.0°
ILS-DME 34	IKG	1015MHz (CH-54X)	2200 - 1300	314741.11N/ 1304336.81E	880ft	DME : 315m(1034ft) inside FM RWY 34 THR, 135m(443ft) E of RCL.
MSAS		1575.42MHz	H24			Transmitting antennas are satellite based

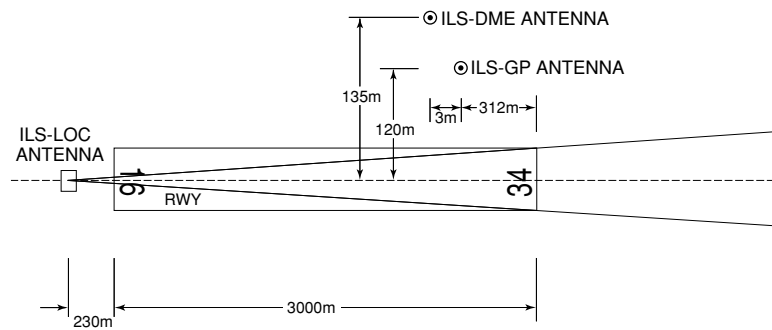

- REMARKS : 1. ILS-LOC beam BRG(MAG) 337°  
 2. HGT of ILS REF datum 17.3m (57ft)  
 3. GP Angle 3.0°  
 4. ELEV of ILS-DME 268.1m (880ft)

**RJFK AD 2.20 LOCAL TRAFFIC REGULATIONS**

1. Airport regulations

**1.1 Aircraft operations other than scheduled flights or in an emergency**

Owing to congestion on the ACFT aprons, operators of transient ACFT are requested to obtain prior permission from CAB KAGOSHIMA(TEL:0995-58-4470), EXC SKD FLT and ACFT in an emergency.

**1.2 管制方式**

**1.2 ATC Procedures**

1.2.1 ATC Clearance

ATC clearance will be obtained by "Voice radiotelephone (Voice RTF)" or "Departure Clearance by data link (DCL)".  
Shown in detail below (a) or (b).

CLEARANCE FLOW	(a) Voice RTF	(b) DCL Refer to ENR1.5.4.1 (Operation for Departure Clearance by data link (DCL))
REQUEST CLEARANCE	Call "Kagoshima Delivery" (121.8MHz) at 5 minutes before starting engines, with the following information. (1)Call sign (2)Destination (3)Proposed flight level/altitude (alternative flight level/altitude, if any) (4)Parking position (spot number)	- Send RCD message at 5 minutes before starting engines. - Monitor "Kagoshima Delivery"(121.8MHz). NOTE: - Start monitoring "Kagoshima Delivery"(121.8MHz) once RCD message is sent. In case coordination is required, "Kagoshima Delivery" calls the pilot on Voice RTF.
OTHERS	After receiving clearance from "Kagoshima Delivery", monitor "Kagoshima Ground"(121.7MHz). Call "Kagoshima Ground" when ready for push back/for taxiing.	

1.2.2 インターセクション・デパーチャー

1.2.2 Intersection departure

- (1) 出発機はパイロットの同意なしに誘導路 T7 からのインターセクション・デパーチャーを指示されることがある。誘導路 T7 から出発できない場合は、管制官に対してその旨通報すること。
- (2)AD1.1.6.3.2.2(2)に記載されている出発機間の管制間隔は、誘導路 T7 から出発する航空機には適用されない。  
AD1.1.6.3.2.2(2)における間隔を必要とする航空機は、鹿児島島グランド / タワーに対してその旨通報すること。

- (1)Departing aircraft may be instructed intersection departure from TWY T7 without pilot's consent.  
Aircraft unable to depart from TWY T7 shall advise ATC accordingly.
- (2)Separation for departure as in AD1.1.6.3.2.2(2) will not be applied to aircraft departing from TWY T7.  
Aircraft requiring separation in AD1.1.6.3.2.2(2) shall advise "Kagoshima Ground/ Tower" accordingly.

1.2.3 CDO ( 継続降下運航方式 )

1.2.3 CDO (Continuous Descent Operation)

鹿児島空港への CDO は次に掲げる方式に従うこと。

Pilot shall comply following procedures when conduct CDO at Kagoshima AP.

- (1) 適用時間  
鹿児島空港到着予定時刻が 1930JST から運用時間終了まで
- (2) 対象経路  
滑走路 34 運用時  
SPICA から SIMAZ EAST ARRIVAL を経由する経路
- (3) 実施方式  
A. CDO の要求及び承認  
a) 航空機からの CDO の要求及び管制機関からの承認は、次表の CDO 経路名を用いて行う。  
CDO 経路には高度制限が付加されていることに留意すること。  
b) 使用滑走路が変更になった場合、CDO の中止が指示される。

- (1) Applicable time  
ETA at Kagoshima airport between 1030UTC and ATC operation terminated.
- (2) Routes applicable for CDO  
When RWY34 in use  
Arrival routes via SPICA and join SIMAZ EAST ARRIVAL
- (3) Procedures  
A. Request and clearance of CDO  
a) CDO route names listed below are used when pilot requests CDO and when ATC clears CDO. There are altitude restrictions on CDO routes.  
b) ATC cancels CDO when RWY in use is changed.

B. CDO の要求時期		B. Timing for requesting CDO	
航空機は、降下開始点に到達する時刻の 10 分前までに、降下開始点を付して、管制機関に対して CDO の要求を行うこと。		Pilot should request CDO not later than 10 minutes before reaching Top of Descent (TOD) with position of TOD.	
Runway 34			
CDO route name	Route		
Runway 34 CDO Number 1	SUC Y757/DONKY Y75 VEKVO Y757 SPICA "SIMAZ EAST ARRIVAL" [Altitude Restriction] Cross SPICA at or above 10,000ft, cross JANUS at or above 6,000ft, cross CELES at or above 4,100ft, cross KEPLA at or above 3,300ft, cross MUSES at or above 3,100ft, cross SIMAZ at or above 2,800ft.		
Runway 16			
CDO route name	Route		
	(Not established)		

2. Taxiing to and from stands

Nil
-----

3. Parking area for small aircraft(General aviation)

Nil
-----

4. Parking area for helicopters

Nil
-----

5. Apron - taxiing during winter conditions

Nil
-----

6. Taxiing - limitations

Wing tip clearance at the TWY intersection (REF. AD1.1.6.8)

Wing tip clearance at the TWY intersection between the aircraft holding at the stop marking on the TWY and the other aircraft taxiing behind it are as follows.

When B744 holding at the stop marking on TWY T2, T6 or T7

Wing Span (WS) of aircraft taxiing on TWY P1 - P2 or P5 - P6	WS ≤ 21.4m	WS > 21.4m
Wing tip clearance	*B	*C

Legend:

\*A wing tip clearance ≥ 15m

\*B 6.5m ≤ wing tip clearance < 15m

\*C wing tip clearance < 6.5m

7. School and training flights - technical test flights - use of runways

Nil
-----

8. Helicopter traffic - limitation

Nil

9. Removal of disabled aircraft from runways

Nil

**RJFK AD 2.21 NOISE ABATEMENT PROCEDURES**

<p><b>1. 騒音軽減運航方式</b></p> <p>すべてのジェット機に対して、空港周辺における航空機騒音軽減のため、運航の安全に支障のない範囲で、以下の方式が適用される。ただし、これらの方式によることができない航空機は実効的にこれらと同等と認められる代替方式を実施するものとする。</p> <p>(1) 離陸について（滑走路 16/34） 急上昇方式</p> <p>(2) 着陸について（滑走路 16/34） ディレイド・フラップ進入方式及び低フラップ角着陸方式</p> <p>(3) リバース・スラストについて なし</p> <p><b>2. 優先滑走路方式</b> なし</p> <p><b>3. 優先飛行経路</b> なし</p>	<p><b>1. Noise Abatement Operating Procedures</b></p> <p>For all jet aircraft, in order to reduce aircraft noise in the vicinity of airport, the following procedures shall be applied unless compliance of the procedures adversely affects the safety of aircraft operations. In case that the aircraft is unable to take these procedures, pilots should execute alternative procedures which are considered to be practically equivalent.</p> <p>(1) For take-off from RWY16/34 Steepest Climb Procedure</p> <p>(2) For landing to RWY16/34 Delayed Flap Approach Procedure and Reduced Flap Setting Procedure</p> <p>(3) Reverse Thrust Nil</p> <p><b>2. Preferential Runways Procedures</b> Nil</p> <p><b>3. Noise Preferential Routes</b> Nil</p>
--	--



**RJFK AD 2.22 FLIGHT PROCEDURES**

**1. TAKE OFF MINIMA**

	RWY	ACFT CAT	REDL & RCLL		REDL or RCLL or RCL Marking		NIL (DAYTIME ONLY)	
			RVR	VIS	RVR	VIS	RVR	VIS
Multi-Engine ACFT with TKOF ALTN AP FILED	16	A,B,C,D	-	400m	-	400m	-	500m
	34	A,B,C,D	400m	400m	400m	400m	-	500m
OTHER	16	A,B,C,D	AVBL LDG MINIMA					
	34	A,B,C,D						

**2. Trajectorized Airport Traffic Data Processing System (TAPS)**

Aircraft flying in Kagoshima approach control area under its control will be instructed to reply with discrete code on Mode A/3 and Mode C.

If an aircraft has no capability of replying with discrete code, the pilot shall report ATC if so instructed.

鹿児島アプローチの指示のもとに、当該進入管制区を飛行する航空機は、モード A/3 の二次レーダー個別コード及びモード C による応答を指示される。

二次レーダー個別コードを搭載していない航空機が当該コードによる応答を指示された場合は、管制官に対し、その旨通報すること。

**3. Lost Communication Procedures for Arrival Aircraft under radar navigational guidance**

If radio communications with Kagoshima Approach/Radar are lost for 30 seconds, Squawk Mode A/3 Code 7600 and :

- 1) Contact Kagoshima tower.
- 2) If unable, proceed in accordance with visual flight rules.
- 3) If unable, proceed to KAJIKI VOR at the last assigned altitude or 4000 feet whichever is higher, and execute approach.

Note : Procedures other than above will be issued when situation requires.

**RJFK AD 2.23 ADDITIONAL INFORMATION**

Volcano SAKURAJIMA located 3135N/13040E being active

---

**RJKF AD 2.24 CHARTS RELATED TO AN AERODROME**

Aerodrome/Heliport Chart-1  
Aerodrome/Heliport Chart-2  
Aerodrome Obstacle Chart - type A (RWY16/34)  
Aerodrome Obstacle Chart - type B (RWY16/34)

Standard Departure Chart - Instrument (OVSID)

Standard Departure Chart - Instrument (MIDAI-RNAV)  
Standard Departure Chart - Instrument (ATRUK-RNAV)  
Standard Departure Chart - Instrument (MIZOBE-RNAV)  
Standard Arrival Chart - Instrument (SIMAZ-RNAV)  
Standard Arrival Chart - Instrument (KINKOH-RNAV)  
Standard Arrival Chart - Instrument (OGOJO, YUKSA, OIDON-RNAV)  
Instrument Approach Chart (ILS Z or LOC Z RWY34)  
Instrument Approach Chart (ILS Y or LOC Y RWY34)  
Instrument Approach Chart (VOR RWY34)  
Instrument Approach Chart (VOR A)  
Instrument Approach Chart (RNP RWY34)  
Instrument Approach Chart (RNP RWY16)  
Other Chart (KINKO VISUAL RWY34)  
Other Chart (Visual REP)  
Other Chart (LDG CHART)  
Other Chart (MVA CHART)

**KAGOSHIMA AP**  
ELEV 271.6m(891ft) ARP

**MARKING AIDS**

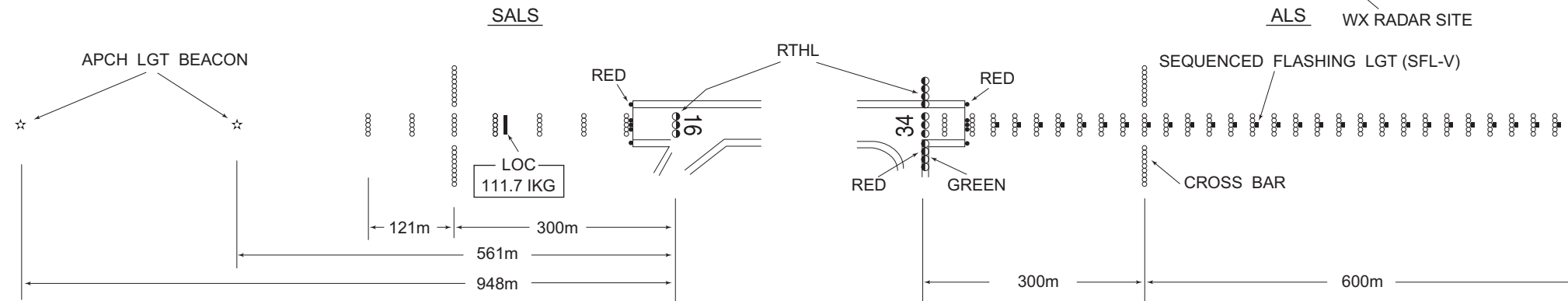
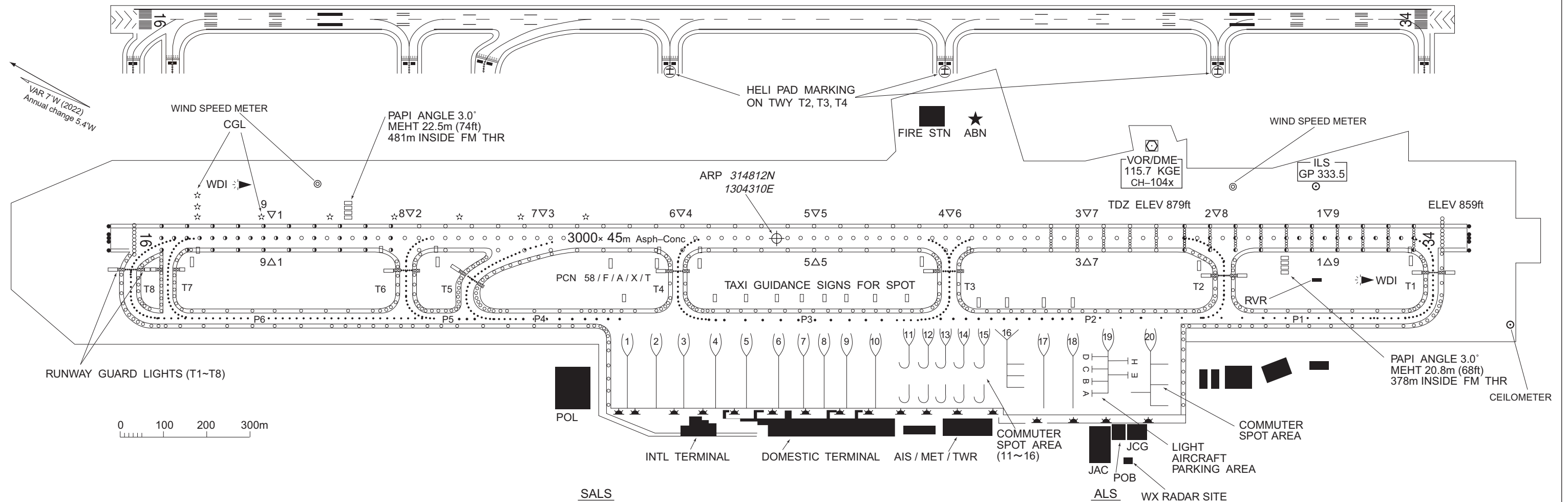
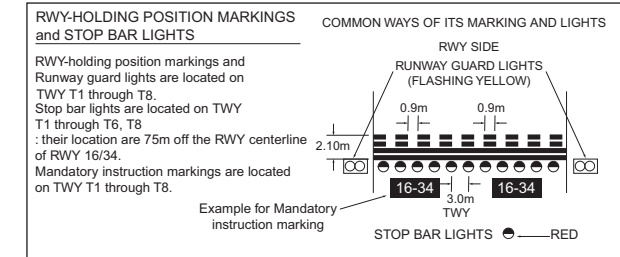

CHANGE : TWY T7 installed. TWY T8 renamed.

RJFK / KAGOSHIMA

AD CHART

CHANGE : TWY T7 installed. TWY T8 renamed.

**KAGOSHIMA AIRPORT**

ELEV 271.6m(891ft) ARP

VAR 7°W (2022)  
Annual change 5.4°W

Designation	Call Sign	Frequency (MHz)
ATIS	Kagoshima Airport	127.05
DLVRY	Kagoshima Delivery	121.8
GND	Kagoshima Ground	121.7
TWR	Kagoshima Tower	118.2 126.2 261.2

FIRE STN

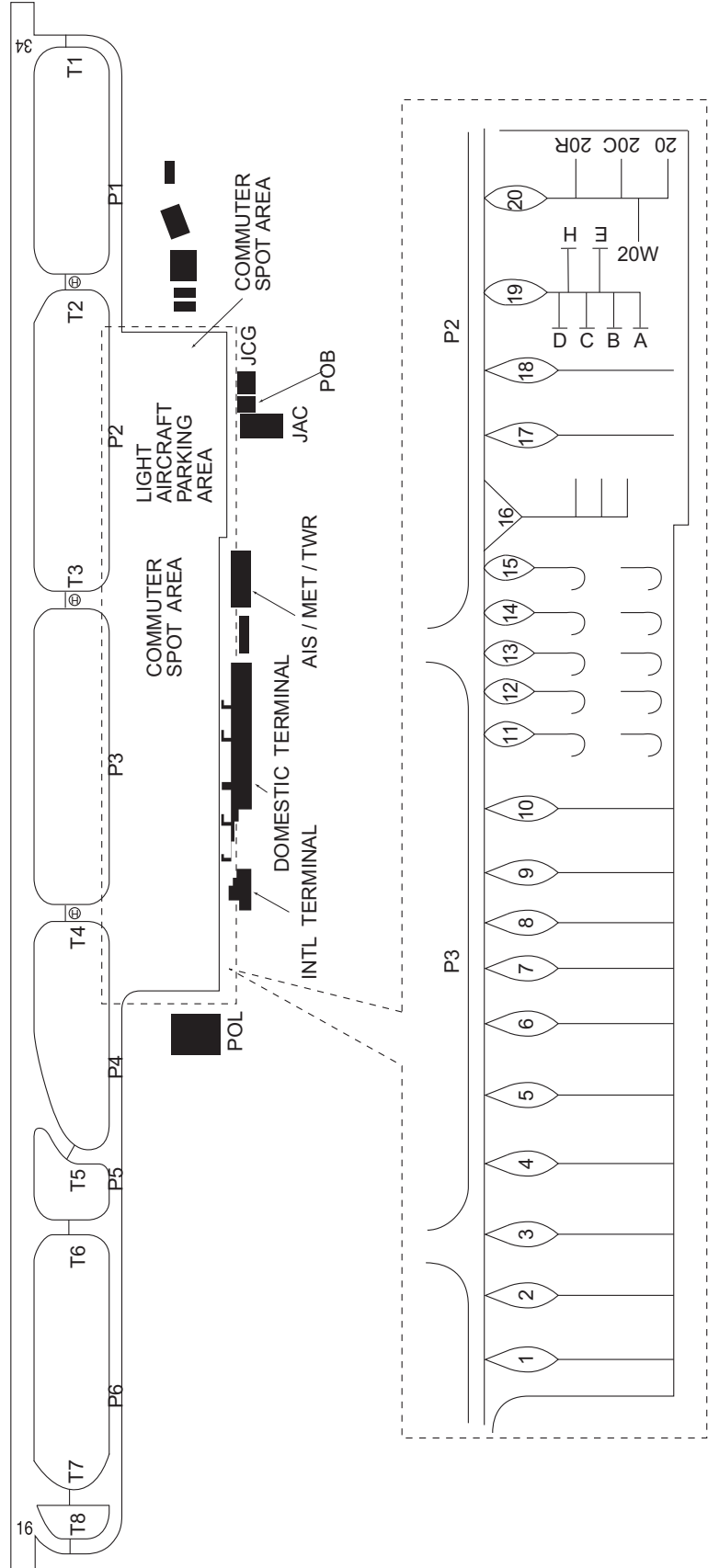

DIMENSIONS AND ELEVATIONS IN FEET BEARINGS ARE MAGNETIC  
Transverse Mercator Projection

**AERODROME OBSTACLE CHART - ICAO  
TYPE A (OPERATING LIMITATIONS)**

MAGNETIC VARIATION 7°W - OCT 2022

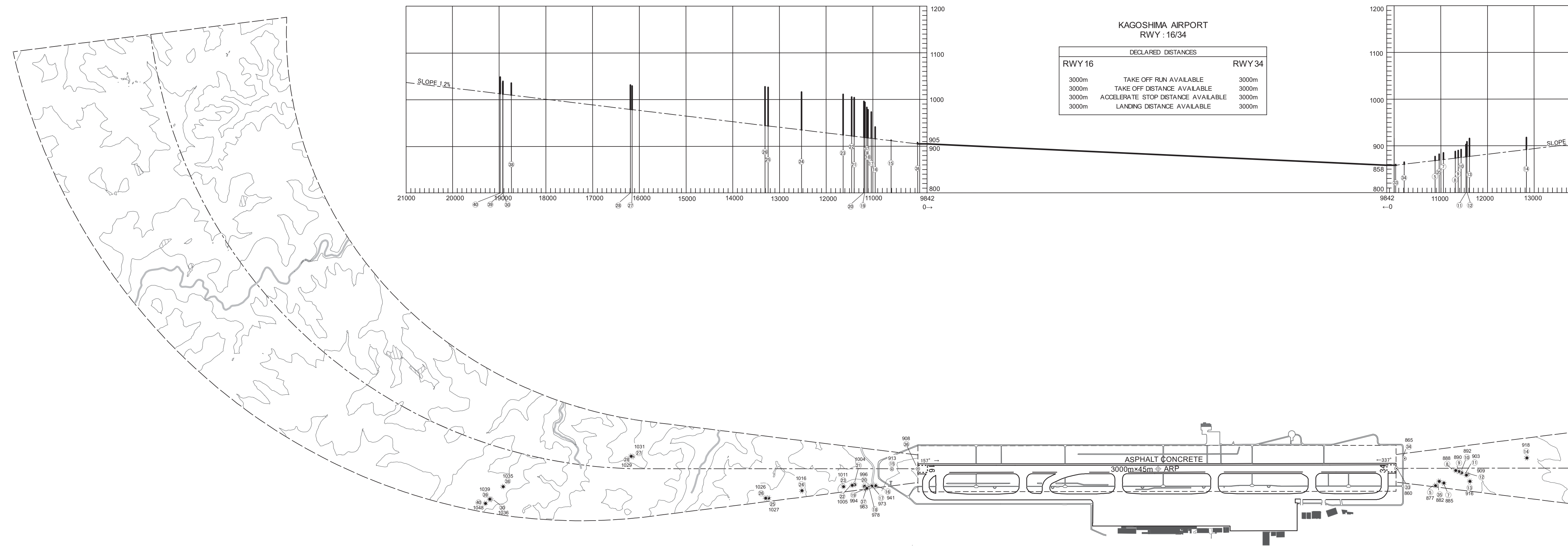

LEGEND	AMENDMENT RECORD		
	Nr	DATE	ENTERED BY
① IDENTIFICATION NUMBER			
⊙ POLE, TOWER, SPIRE, ANTENNA, ETC			
* TREE			
⋯ LEVEE			
⊕ RAILROAD			
⋯ RIVER			
⊕ TRANSMISSION LINE OR OVERHEAD CABLE			
△ TRIANGULATION POINT			
★ AERONAUTICAL GROUND LIGHT			
■ BUILDING OR LARGE STRUCTURE			
⋯ CONTOURS(M)			

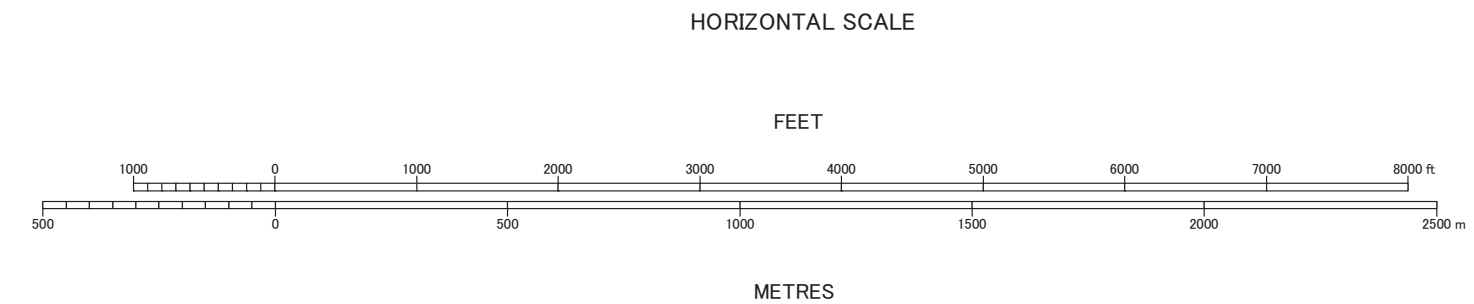

CHANGE : TWY T7 installed.

測量法に基づく国土地理院長承認(使用) R 5.0h 223、国土数値情報(河川、築港輸送道路)

DIMENSIONS AND ELEVATIONS IN FEET BEARINGS ARE MAGNETIC  
Transverse Mercator Projection

AERODROME OBSTACLE CHART-ICAO  
TYPE B



CHANGE : TWY T7 installed.

LEGEND

- AERODROME REFERENCE POINT  
31° 48' 2" N 130° 43' 10" E
- POLE, TOWER, SPIRE, ANTENNA, ETC
- AERONAUTICAL GROUND LIGHT
- OBSTRUCTION LIGHT
- BUILDING OR LARGE STRUCTURE
- RAILROAD TRIANGULATION POINT
- TRANSMISSION LINE OR OVERHEAD CABLE
- LEVEE
- TREE
- LAKE
- RIVER
- CONTOURS (ft)

AMENDMENT RECORD

Nr	DATE	ENTERED BY

HORIZONTAL SCALE

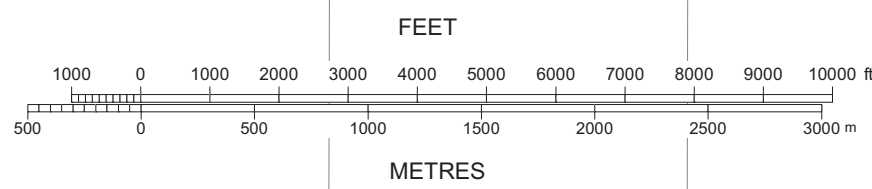

測量法に基づく国土地理院長承認(使用) R 5Jhs 223、国土数値情報(河川、湖沼、緊急輸送道路、鉄道)

STANDARD DEPARTURE CHART - INSTRUMENT

RJFK / KAGOSHIMA

SID and TRANSITION

CHANGE : OVSID ONE DEPARTURE established. KAJIKI TRANSITION established. PROC course(SASIK TRANSITION, KAGOSHIMA TRANSITION).  
SOGIE THREE DEPARTURE, SAKURAJIMA TRANSITION abolished.

OVSID ONE DEPARTURE

RWY 16 : Climb RWY HDG to KGE2.0DME, turn left HDG 303° ...

RWY 34 : Climb RWY HDG to 2000FT, turn right...  
... to intercept and proceed via KGE R348 to OVSID.

Note RWY16 : 5.0% climb gradient required up to 1300FT.

RWY34 : 5.0% climb gradient required up to 2000FT.

OBST ALT 1181FT located at 1.4NM 319° FM end of RWY34.

OBST ALT 2067FT located at 6.7NM 345° FM end of RWY34.

KAJIKI TRANSITION

From over OVSID, turn left, direct to KGE VOR/DME.  
Cross KGE VOR/DME at or above 7000FT.

SASIK TRANSITION

From over OVSID, via KGE R348 to SASIK.

KAGOSHIMA TRANSITION

From over OVSID, turn left to intercept and proceed via HKC R003 to HKC VORTAC.

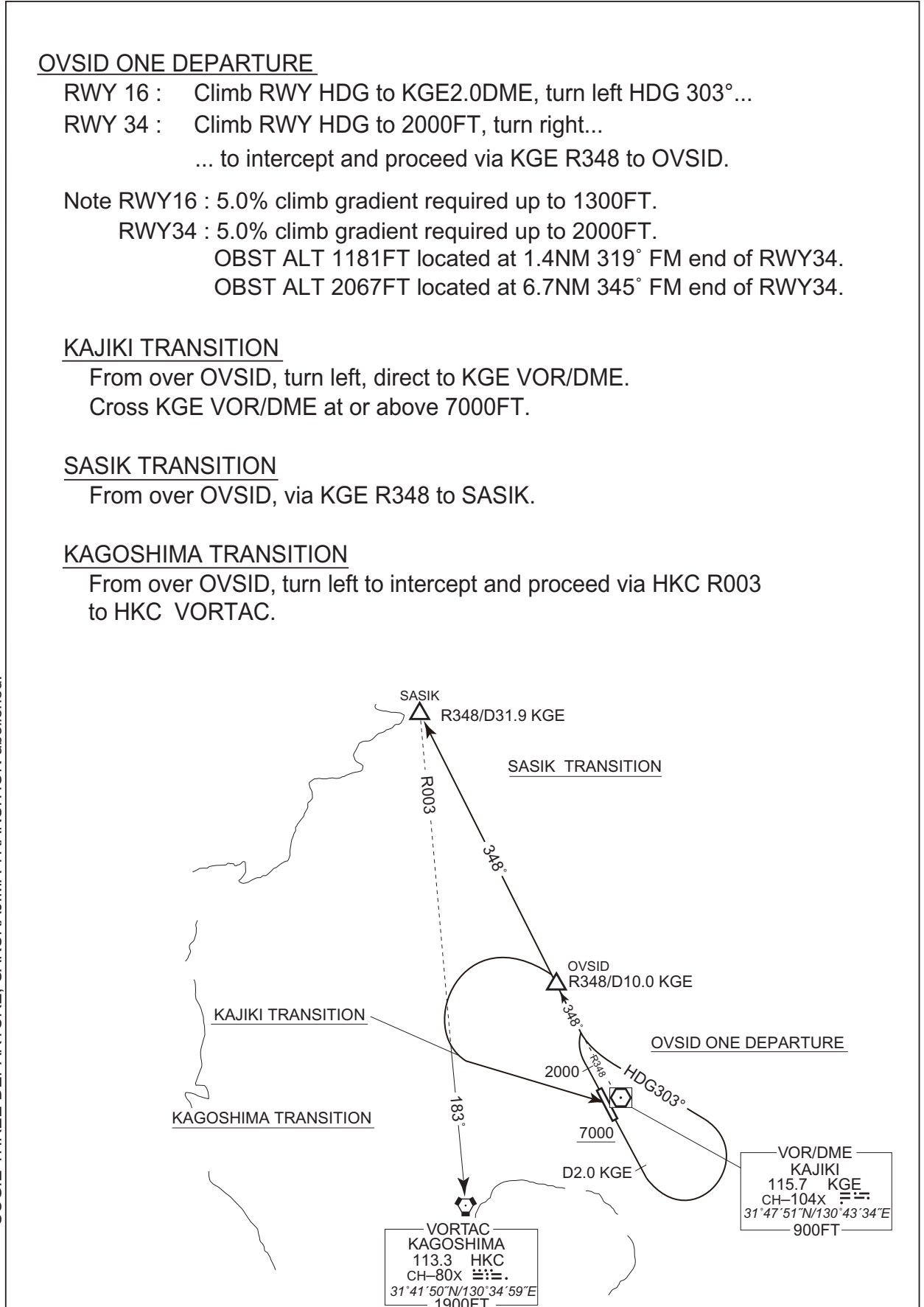

STANDARD DEPARTURE CHART - INSTRUMENT

RJFK / KAGOSHIMA

RNAV SID

MIDAI THREE DEPARTURE		RNAV 1
Note 1) DME/DME/IRU or GNSS required. ※The aircraft equipped with only DME/DME/IRU must be able to update its position without delay at the starting point of take-off roll. 2) RADAR service required.	Critical DME	RWY16 : HKC:7NM to OICHI — 2NM to OICHI KGE:7NM to OICHI — 2NM to OICHI
	DME GAP	RWY16 : DER — 7NM to OICHI RWY34 : DER — 12NM to SMIKO
	Inappropriate Nav aids	See AD 1.1.6.10.3. Inappropriate NAV AIDs for RNAV1

VAR 7°W

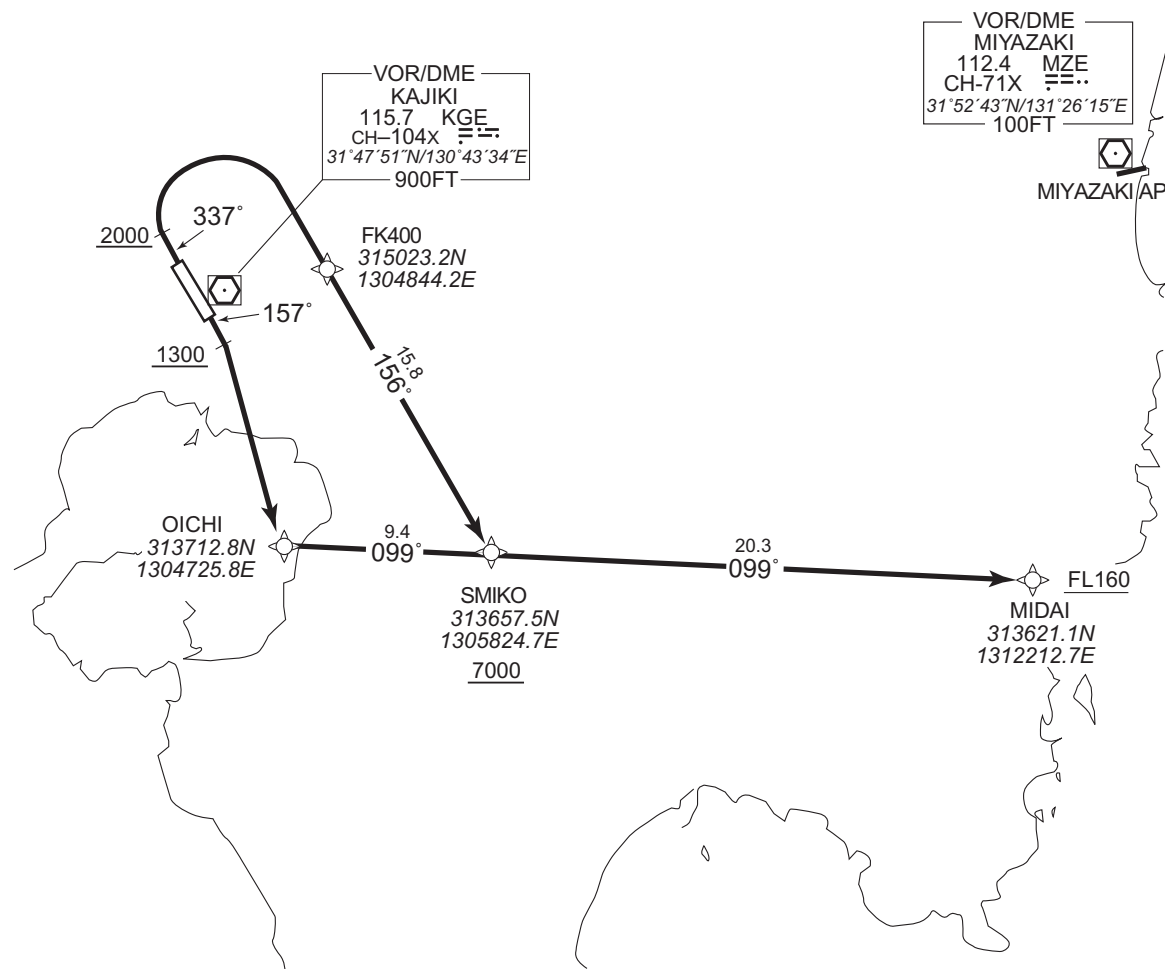

RWY16 : Climb on HDG 157° at or above 1300FT, turn right direct to OICHI, to SMIKO at or above 7000FT, to MIDAI at or above FL160.  
 RWY34 : Climb on HDG 337° at or above 2000FT, turn right direct to FK400, to SMIKO at or above 7000FT, to MIDAI at or above FL160.  
 Note RWY34 : 5.0% climb gradient required up to 3100FT.  
 OBST ALT 3117FT located at 7.7NM 046° FM end of RWY34.



STANDARD DEPARTURE CHART - INSTRUMENT

RJFK / KAGOSHIMA

RNAV SID

MIDAI THREE DEPARTURE

RWY16

Serial Number	Path Descriptor	Waypoint Identifier	Fly Over	Course °M(°T)	Magnetic Variation	Distance (NM)	Turn Direction	Altitude (FT)	Speed (KIAS)	Vertical Angle	Navigation Specification
001	VA	—	—	157 (150.1)	-7.2	—	—	+1300	—	—	RNAV1
002	DF	OICHI	—	—	-7.2	—	R	—	—	—	RNAV1
003	TF	SMIKO	—	099 (091.5)	-7.2	9.4	—	+7000	—	—	RNAV1
004	TF	MIDAI	—	099 (091.6)	-7.2	20.3	—	+FL160	—	—	RNAV1

RWY34

Serial Number	Path Descriptor	Waypoint Identifier	Fly Over	Course °M(°T)	Magnetic Variation	Distance (NM)	Turn Direction	Altitude (FT)	Speed (KIAS)	Vertical Angle	Navigation Specification
001	VA	—	—	337 (330.1)	-7.2	—	—	+2000	—	—	RNAV1
002	DF	FK400	—	—	-7.2	—	R	—	—	—	RNAV1
003	TF	SMIKO	—	156 (148.5)	-7.2	15.8	—	+7000	—	—	RNAV1
004	TF	MIDAI	—	099 (091.6)	-7.2	20.3	—	+FL160	—	—	RNAV1

STANDARD DEPARTURE CHART - INSTRUMENT

RJFK / KAGOSHIMA

RNAV SID and TRANSITION

ATRUK ONE DEPARTURE ASHIKITA TRANSITION		RNAV1
Note 1) DME/DME/IRU or GNSS required. ※The aircraft equipped with only DME/DME/IRU must be able to update its position without delay at the starting point of take-off roll. 2) RADAR service required.	Critical DME	RWY16 : HKC 6.0NM to FK601 - FK601 11.0NM to ATRUK - 4.0NM to ATRUK KGE 6.0NM to FK601 - 5.0NM to FK601 4.0NM to FK601 - 4.0NM to ATRUK MZE 6.0NM to FK601 - 4.0NM to FK601 3.0NM to ATRUK - 1.0NM to ATRUK RWY34 : HKC 3.0NM from DER - 5.0NM to ATRUK KGE 5.0NM to OVSID - 3.0NM to OVSID 1.0NM to OVSID - 5.0NM to ATRUK MZE 3.0NM to ATRUK - 1.0NM to ATRUK
	DME GAP	RWY16 : DER - 6.0NM to FK601 RWY34 : DER - 3.0NM from DER
	Inappropriate Navaids	See AD1.1.6.10.3 Inappropriate NAVAIDs for RNAV1

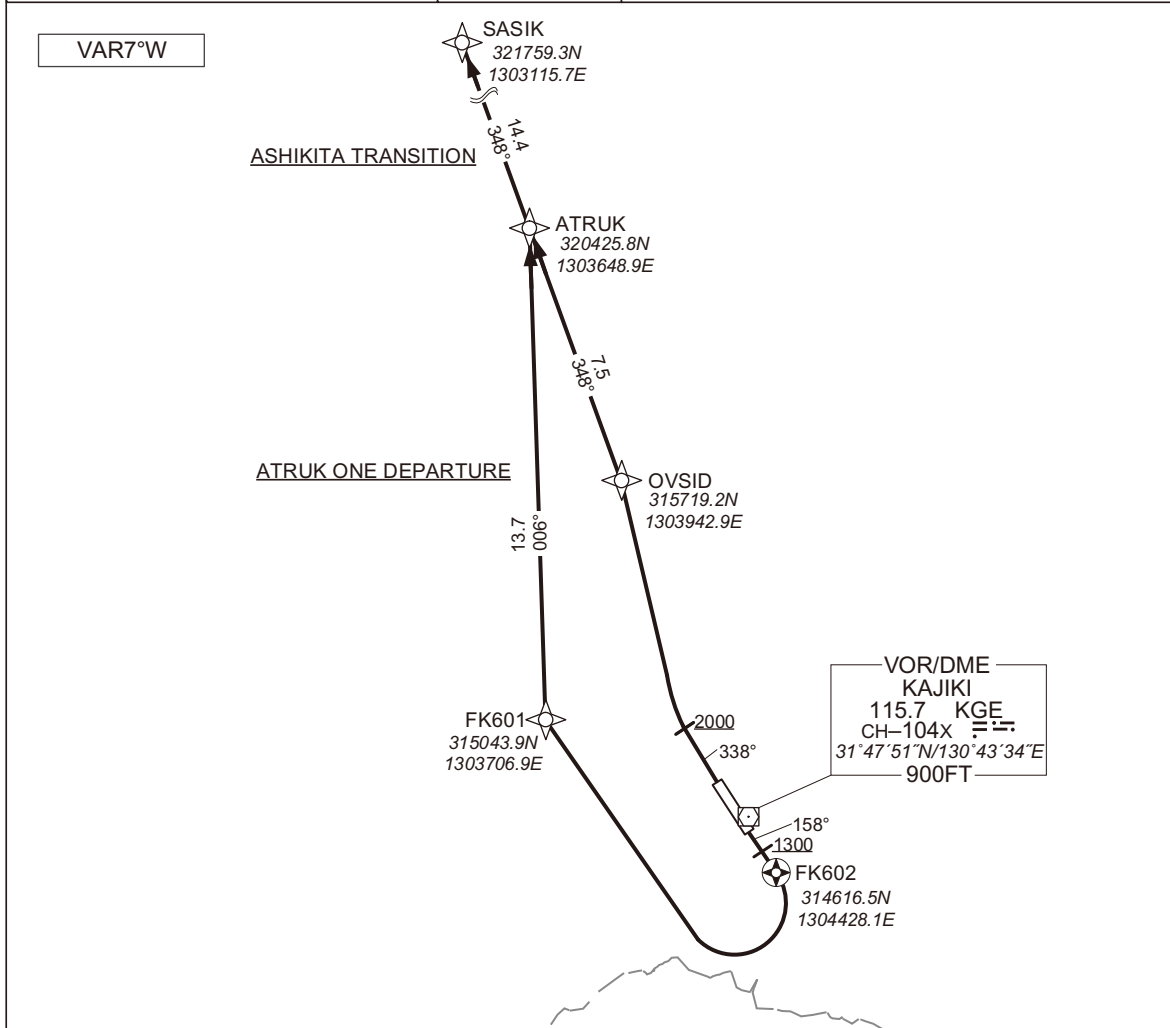

**ATRUK ONE DEPARTURE**  
 RWY16 : Climb on HDG158° at or above 1300FT, direct to **FK602**, turn right direct to **FK601**, to **ATRUK**.  
 RWY34 : Climb on HDG338° at or above 2000FT, turn right direct to **OVSID**, to **ATRUK**.

Note RWY16 : 7.0% climb gradient required up to 2000FT.  
 OBST ALT 896FT located at 0.6NM 141° FM end of RWY16.

Note RWY34 : 5.0% climb gradient required up to 2000FT.  
 OBST ALT 1181FT located at 1.4NM 319° FM end of RWY34.  
 OBST ALT 2067FT located at 6.7NM 345° FM end of RWY34.

**ASHIKITA TRANSITION**  
 From **ATRUK**, to **SASIK**.

CHANGE : New PROC.

STANDARD DEPARTURE CHART - INSTRUMENT

RJFK / KAGOSHIMA

RNAV SID and TRANSITION

ATRUK ONE DEPARTURE

**RWY16**

Serial Number	Path Descriptor	Waypoint Identifier	Fly Over	Course °M(°T)	Magnetic Variation	Distance (NM)	Turn Direction	Altitude (FT)	Speed (KIAS)	Vertical Angle	Navigation Specification
001	VA	-	-	158 (150.1)	-7.4	-	-	+1300	-	-	RNAV1
002	DF	FK602	Y	-	-7.4	-	-	-	-	-	RNAV1
003	DF	FK601	-	-	-7.4	-	R	-	-	-	RNAV1
004	TF	ATRUK	-	006 (358.9)	-7.4	13.7	-	-	-	-	RNAV1

**RWY34**

Serial Number	Path Descriptor	Waypoint Identifier	Fly Over	Course °M(°T)	Magnetic Variation	Distance (NM)	Turn Direction	Altitude (FT)	Speed (KIAS)	Vertical Angle	Navigation Specification
001	VA	-	-	338 (330.1)	-7.4	-	-	+2000	-	-	RNAV1
002	DF	OVSID	-	-	-7.4	-	R	-	-	-	RNAV1
003	TF	ATRUK	-	348 (340.9)	-7.4	7.5	-	-	-	-	RNAV1

ASHIKITA TRANSITION

Serial Number	Path Descriptor	Waypoint Identifier	Fly Over	Course °M(°T)	Magnetic Variation	Distance (NM)	Turn Direction	Altitude (FT)	Speed (KIAS)	Vertical Angle	Navigation Specification
001	IF	ATRUK	-	-	-7.4	-	-	-	-	-	RNAV1
002	TF	SASIK	-	348 (340.9)	-7.4	14.4	-	-	-	-	RNAV1

CHANGE : New PROC.

STANDARD DEPARTURE CHART - INSTRUMENT

RJFK / KAGOSHIMA

RNAV SID

MIZOBE ONE DEPARTURE		RNAV1
Note 1) DME/DME/IRU or GNSS required. ※The aircraft equipped with only DME/DME/IRU must be able to update its position without delay at the starting point of take-off roll. 2) RADAR service required.	Critical DME	RWY16 : HKC 9.0NM to HKC - 3.0NM to HKC KGE 9.0NM to HKC - HKC SGE 3.0NM to HKC - HKC RWY34 : HKC 2.0NM from DER - 14.0NM to HKC KGE 2.0NM from DER - 9.0NM to HKC 7.0NM to HKC - 6.0NM to HKC 4.0NM to HKC - 2.0NM to HKC SGE 3.0NM to HKC - HKC
	DME GAP	RWY16 : DER - 9.0NM to HKC RWY34 : DER - 2.0NM from DER
	Inappropriate Nav aids	See AD1.1.6.10.3 Inappropriate NAV AIDs for RNAV1

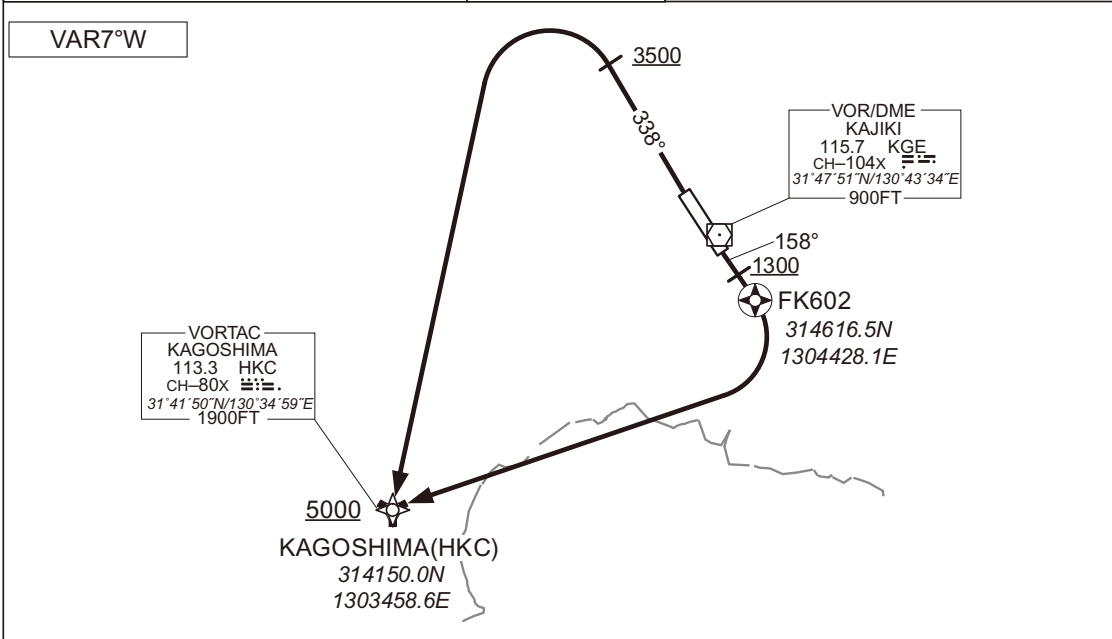

RWY16 : Climb on HDG158° at or above 1300FT, direct to FK602, turn right direct to HKC at or above 5000FT.  
 RWY34 : Climb on HDG338° at or above 3500FT, tum left direct to HKC at or above 5000FT.

Note RWY16 : 7.0% climb gradient required up to 2000FT.  
 OBST ALT 890FT located at 0.6NM 154° FM end of RWY16.  
 Note RWY34 : 5.0% climb gradient required up to 3500FT.  
 OBST ALT 1181FT located at 1.4NM 319° FM end of RWY34.  
 OBST ALT 2067FT located at 6.7NM 345° FM end of RWY34.

RWY16

Serial Number	Path Descriptor	Waypoint Identifier	Fly Over	Course °M(°T)	Magnetic Variation	Distance (NM)	Turn Direction	Altitude (FT)	Speed (KIAS)	Vertical Angle	Navigation Specification
001	VA	-	-	158 (150.1)	-7.4	-	-	+1300	-	-	RNAV1
002	DF	FK602	Y	-	-7.4	-	-	-	-	-	RNAV1
003	DF	HKC	-	-	-7.4	-	R	+5000	-	-	RNAV1

RWY34

Serial Number	Path Descriptor	Waypoint Identifier	Fly Over	Course °M(°T)	Magnetic Variation	Distance (NM)	Turn Direction	Altitude (FT)	Speed (KIAS)	Vertical Angle	Navigation Specification
001	VA	-	-	338 (330.1)	-7.4	-	-	+3500	-	-	RNAV1
002	DF	HKC	-	-	-7.4	-	L	+5000	-	-	RNAV1

CHANGE : New PROC.

STANDARD ARRIVAL CHART -INSTRUMENT

RJFK / KAGOSHIMA

RNAV STAR RWY34

SIMAZ EAST ARRIVAL

RNAV 1

Note 1 ) DME/DME/IRU or GNSS required.  
2 ) RADAR service required.

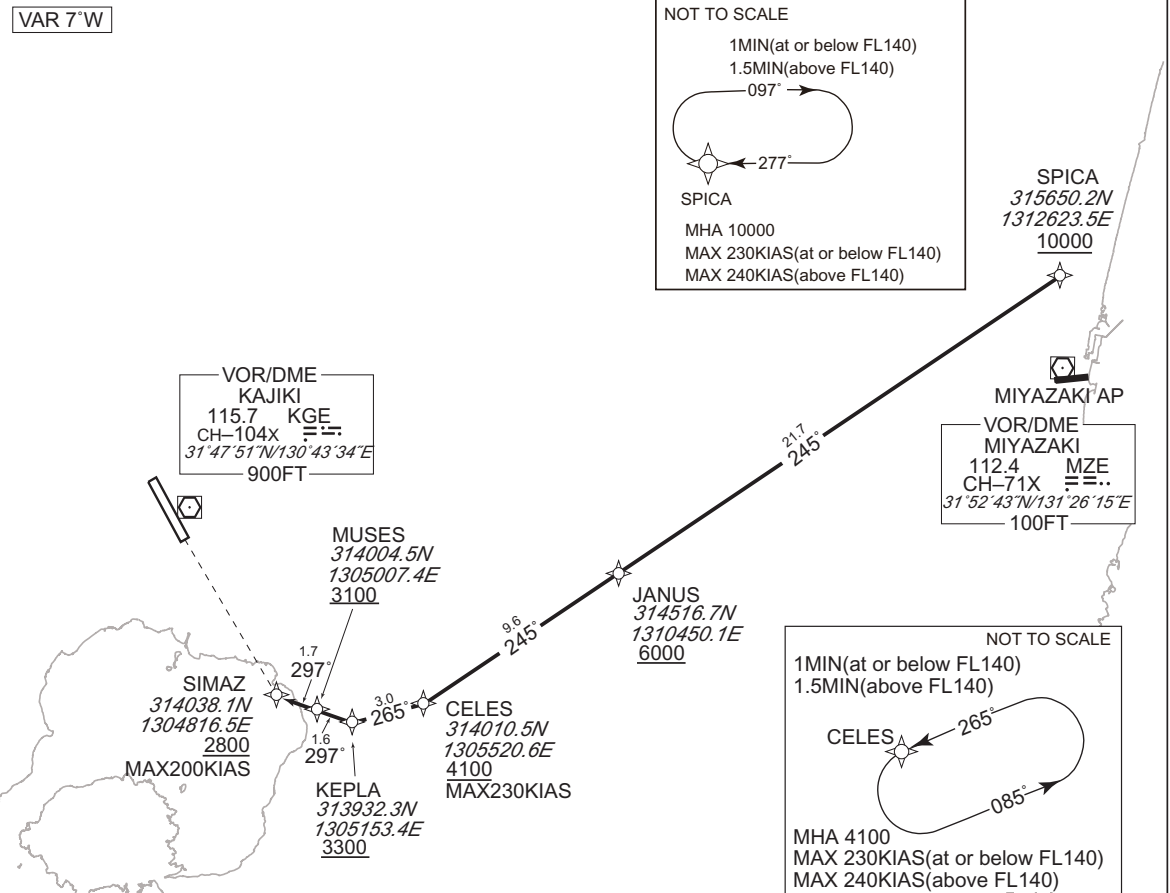

From SPICA at or above 10000FT, to JANUS at or above 6000FT, to CELES at or above 4100FT, to KEPLA at or above 3300FT, to MUSES at or above 3100FT, to SIMAZ at above 2800FT.

Critical DME	-
DME GAP	-
Inappropriate Navaids	See AD1.1.6.10.3. Inappropriate NAVAIDs for RNAV1

CHANGE : RNAV HLDG established(SPICA).

Serial Number	Path Descriptor	Waypoint Identifier	Fly Over	Course °M(°T)	Magnetic Variation	Distance (NM)	Turn Direction	Altitude (FT)	Speed (KIAS)	Vertical Angle	Navigation Specification
001	IF	SPICA	-	-	-7.2	-	-	+10000	-	-	RNAV1
002	TF	JANUS	-	245 (237.8)	-7.2	21.7	-	+6000	-	-	RNAV1
003	TF	CELES	-	245 (237.8)	-7.2	9.6	-	+4100	-230	-	RNAV1
004	TF	KEPLA	-	265 (257.8)	-7.2	3.0	-	+3300	-	-	RNAV1
005	TF	MUSES	-	297 (289.6)	-7.2	1.6	-	+3100	-	-	RNAV1
006	TF	SIMAZ	-	297 (289.6)	-7.2	1.7	-	+2800	-200	-	RNAV1

Path	Waypoint Identifier	Inbound Course °M(°T)	Magnetic Variation	Outbound Time (MIN)	Turn Direction	Minimum Altitude (FT)	Maximum Altitude (FT)	Speed (KIAS)	Navigation Specification
Hold	SPICA	277 (270.1)	-7.4	1.0(-14000) 1.5(+14001)	R	10000	-	-230(-14000) -240(+14001)	RNAV1
Hold	CELES	265 (257.8)	-7.2	1.0(-14000) 1.5(+14001)	L	4100	-	-230(-14000) -240(+14001)	RNAV1

STANDARD ARRIVAL CHART -INSTRUMENT

RJFK / KAGOSHIMA

RNAV STAR RWY34

SIMAZ NORTH ARRIVAL

RNAV 1

Note 1 ) DME/DME/IRU or GNSS required.  
2 ) RADAR service required.

VAR 7°W

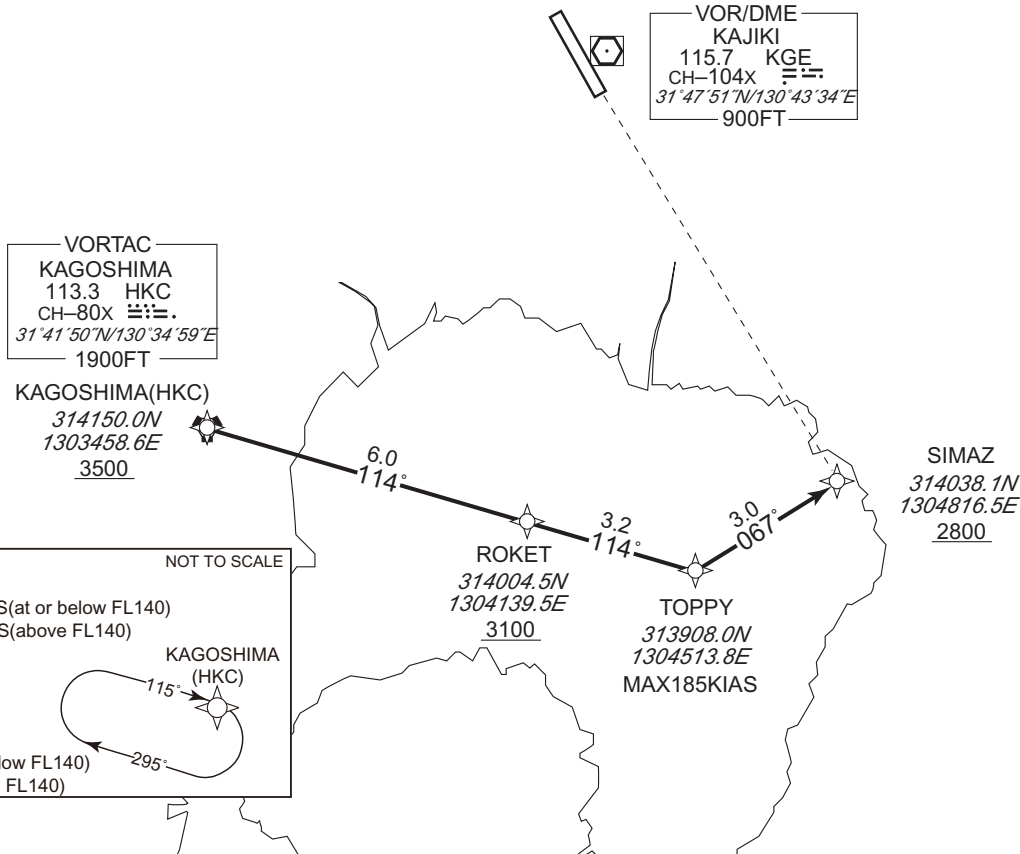

From HKC at or above 3500FT, to ROKET at or above 3100FT, to TOPPY, to SIMAZ at or above 2800FT.

Critical DME	KGE : 3NM to ROKET - SIMAZ
DME GAP	HKC - 3NM to ROKET
Inappropriate Nav aids	See AD1.1.6.10.3. Inappropriate NAVAIDS for RNAV1

Serial Number	Path Descriptor	Waypoint Identifier	Fly Over	Course °M(°T)	Magnetic Variation	Distance (NM)	Turn Direction	Altitude (FT)	Speed (KIAS)	Vertical Angle	Navigation Specification
001	IF	HKC	-	-	-6.9	-	-	+3500	-	-	RNAV1
002	TF	ROKET	-	114 (107.2)	-6.9	6.0	-	+3100	-	-	RNAV1
003	TF	TOPPY	-	114 (107.2)	-6.9	3.2	-	-	-185	-	RNAV1
004	TF	SIMAZ	-	067 (059.9)	-6.9	3.0	-	+2800	-	-	RNAV1

Path	Waypoint Identifier	Inbound Course °M(°T)	Magnetic Variation	Outbound Time (MIN)	Turn Direction	Minimum Altitude (FT)	Maximum Altitude (FT)	Speed (KIAS)	Navigation Specification
Hold	HKC	115 (107.1)	-7.4	1.0(-14000) 1.5(+14001)	R	5000	-	-230(-14000) -240(+14001)	RNAV1

CHANGE : RNAV HLDG established. HLDG for using NAVAID abolished(HKC).

STANDARD ARRIVAL CHART -INSTRUMENT

RJFK / KAGOSHIMA

RNAV STAR RWY34

SIMAZ SOUTH ARRIVAL

RNAV 1

Note 1) DME/DME/IRU or GNSS required.  
2) RADAR service required.

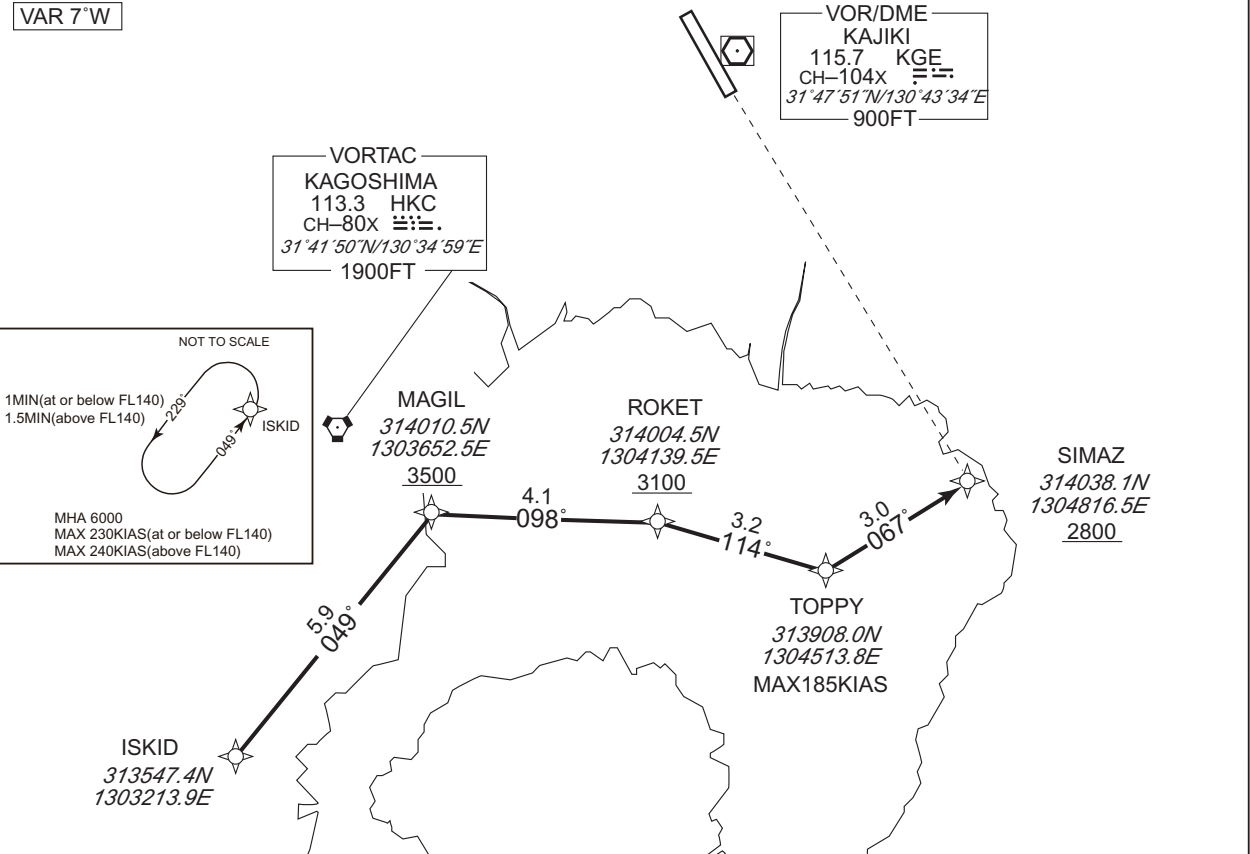

CHANGE : RNAV HLDG established. HLDG for using NAVAID abolished(ISKID).

From ISKID, to MAGIL at or above 3500FT, to ROKET at or above 3100FT, to TOPPY, to SIMAZ at or above 2800FT.

Critical DME	-
DME GAP	ISKID - 3NM to MAGIL 1NM to MAGIL - SIMAZ
Inappropriate Navaids	See AD1.1.6.10.3. Inappropriate NAVAIDs for RNAV1

Serial Number	Path Descriptor	Waypoint Identifier	Fly Over	Course °M(°T)	Magnetic Variation	Distance (NM)	Turn Direction	Altitude (FT)	Speed (KIAS)	Vertical Angle	Navigation Specification
001	IF	ISKID	-	-	-6.9	-	-	-	-	-	RNAV1
002	TF	MAGIL	-	049 (042.0)	-6.9	5.9	-	+3500	-	-	RNAV1
003	TF	ROKET	-	098 (091.4)	-6.9	4.1	-	+3100	-	-	RNAV1
004	TF	TOPPY	-	114 (107.2)	-6.9	3.2	-	-	-185	-	RNAV1
005	TF	SIMAZ	-	067 (059.9)	-6.9	3.0	-	+2800	-	-	RNAV1

Path	Waypoint Identifier	Inbound Course °M(°T)	Magnetic Variation	Outbound Time (MIN)	Turn Direction	Minimum Altitude (FT)	Maximum Altitude (FT)	Speed (KIAS)	Navigation Specification
Hold	ISKID	049 (042.0)	-7.4	1.0(-14000) 1.5(+14001)	L	6000	-	-230(-14000) -240(+14001)	RNAV1

STANDARD ARRIVAL CHART -INSTRUMENT

RJFK / KAGOSHIMA

RNAV STAR RWY34

KINKOH ARRIVAL

RNAV 1

Note 1) DME/DME/IRU or GNSS required.  
2) RADAR service required.

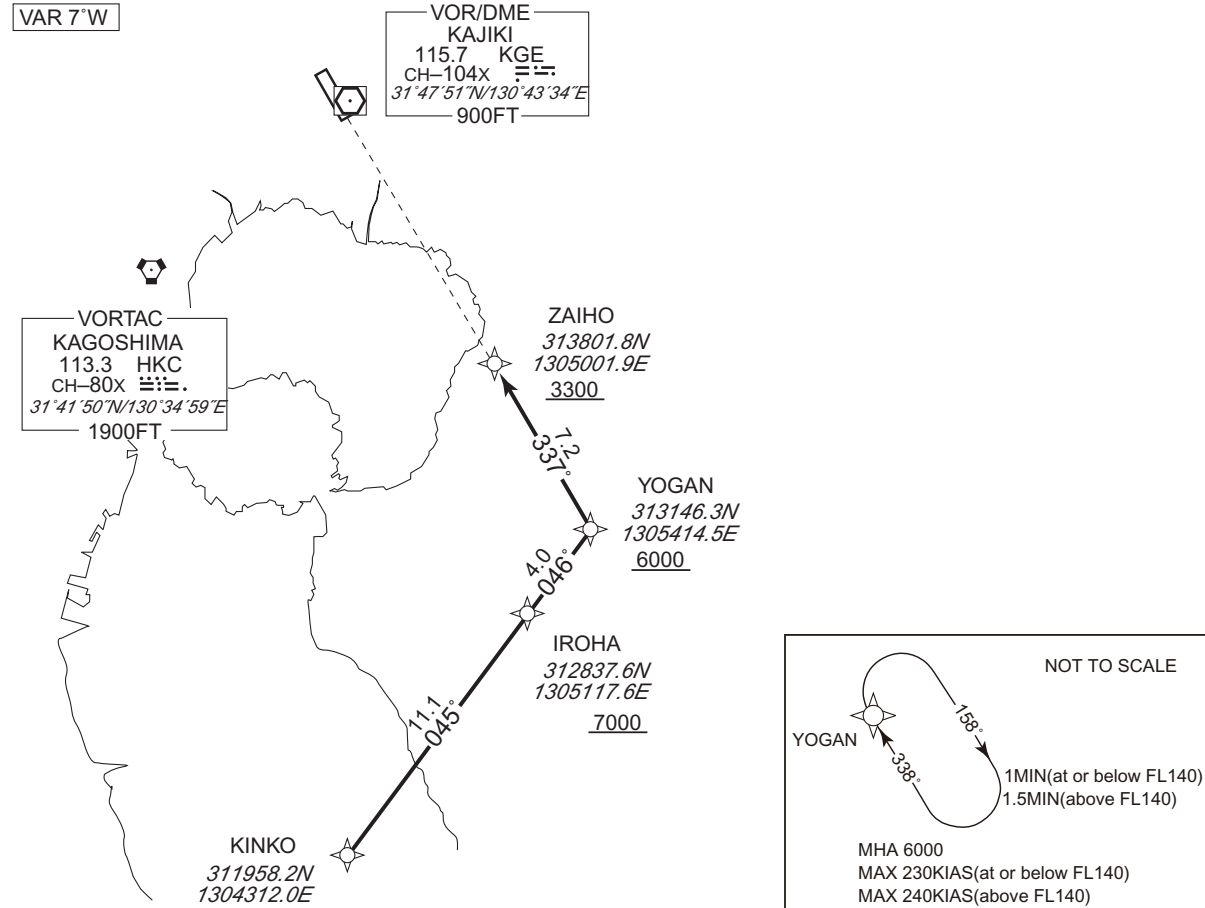

From KINKO, to IROHA at or above 7000FT, to YOGAN at or above 6000FT, to ZAIHO at or above 3300FT.

Critical DME	JAT : 10.2NM to IROHA – 5.7NM to IROHA NHT : 5.6NM to IROHA – 2.4NM to IROHA 2.4NM to ZAIHO – 1.2NM to ZAIHO HKC : 4.4NM to ZAIHO – 1.3NM to ZAIHO
DME GAP	-
Inappropriate NavAids	See AD1.1.6.10.3. Inappropriate NAVAIDs for RNAV1

Serial Number	Path Descriptor	Waypoint Identifier	Fly Over	Course °M(°T)	Magnetic Variation	Distance (NM)	Turn Direction	Altitude (FT)	Speed (KIAS)	Vertical Angle	Navigation Specification
001	IF	KINKO	-	-	-6.9	-	-	-	-	-	RNAV1
002	TF	IROHA	-	045 (038.6)	-6.9	11.1	-	+7000	-	-	RNAV1
003	TF	YOGAN	-	046 (038.6)	-6.9	4.0	-	+6000	-	-	RNAV1
004	TF	ZAIHO	-	337 (330.2)	-6.9	7.2	-	+3300	-	-	RNAV1

Path	Waypoint Identifier	Inbound Course °M(°T)	Magnetic Variation	Outbound Time (MIN)	Turn Direction	Minimum Altitude (FT)	Maximum Altitude (FT)	Speed (KIAS)	Navigation Specification
Hold	YOGAN	338 (330.2)	-7.4	1.0(-14000) 1.5(+14001)	R	6000	-	-230(-14000) -240(+14001)	RNAV1

CHANGE : RNAV HLDG established. HLDG for using NAVAID abolished(YOGAN).



STANDARD ARRIVAL CHART-INSTRUMENT

RJFK / KAGOSHIMA

RNAV STAR RWY16

OGOJO ARRIVAL

RNAV 1

Note 1) DME/DME/IRU or GNSS required.  
2) RADAR service required.

VAR 7°W

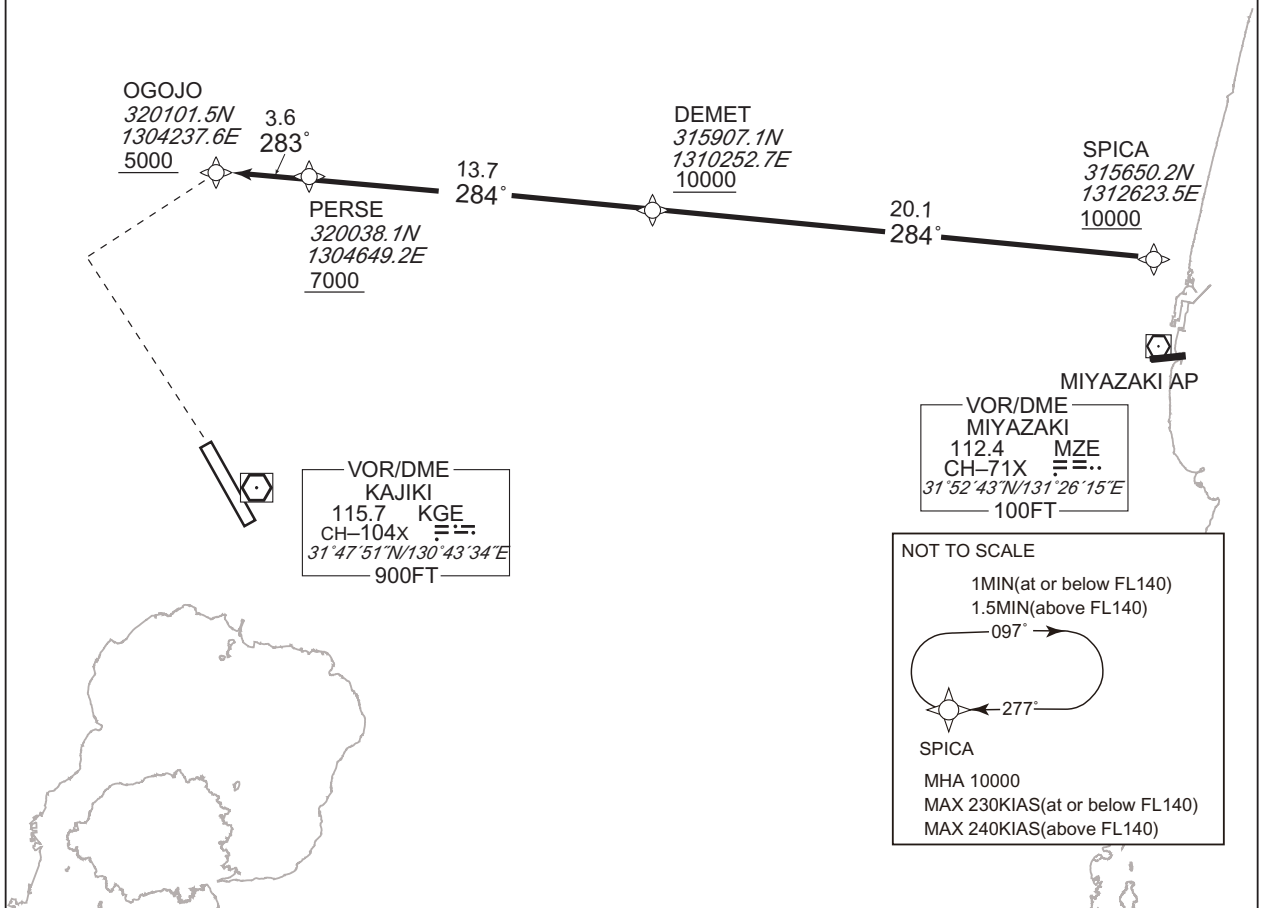

From SPICA at or above 10000FT, to DEMET at or above 10000FT, to PERSE at or above 7000FT, to OGOJO at or above 5000FT.

Critical DME	-	-
DME GAP	-	-
Inappropriate Nav aids	See AD1.1.6.10.3. Inappropriate NAV AIDs for RNAV1	

CHANGE : RNAV HLDG established.

Serial Number	Path Descriptor	Waypoint Identifier	Fly Over	Course °M(°T)	Magnetic Variation	Distance (NM)	Turn Direction	Altitude (FT)	Speed (KIAS)	Vertical Angle	Navigation Specification
001	IF	SPICA	-	-	-7.2	-	-	+10000	-	-	RNAV1
002	TF	DEMET	-	284 (276.6)	-7.2	20.1	-	+10000	-	-	RNAV1
003	TF	PERSE	-	284 (276.4)	-7.2	13.7	-	+7000	-	-	RNAV1
004	TF	OGOJO	-	283 (276.3)	-7.2	3.6	-	+5000	-	-	RNAV1

Path	Waypoint Identifier	Inbound Course °M(°T)	Magnetic Variation	Outbound Time (MIN)	Turn Direction	Minimum Altitude (FT)	Maximum Altitude (FT)	Speed (KIAS)	Navigation Specification
Hold	SPICA	277 (270.1)	-7.4	1.0(-14000) 1.5(+14001)	R	10000	-	-230(-14000) -240(+14001)	RNAV1

STANDARD ARRIVAL CHART-INSTRUMENT

RJFK / KAGOSHIMA

RNAV STAR RWY16

YUKSA ARRIVAL

RNAV 1

Note 1) DME/DME/IRU or GNSS required.  
2) RADAR service required.

VAR 7°W

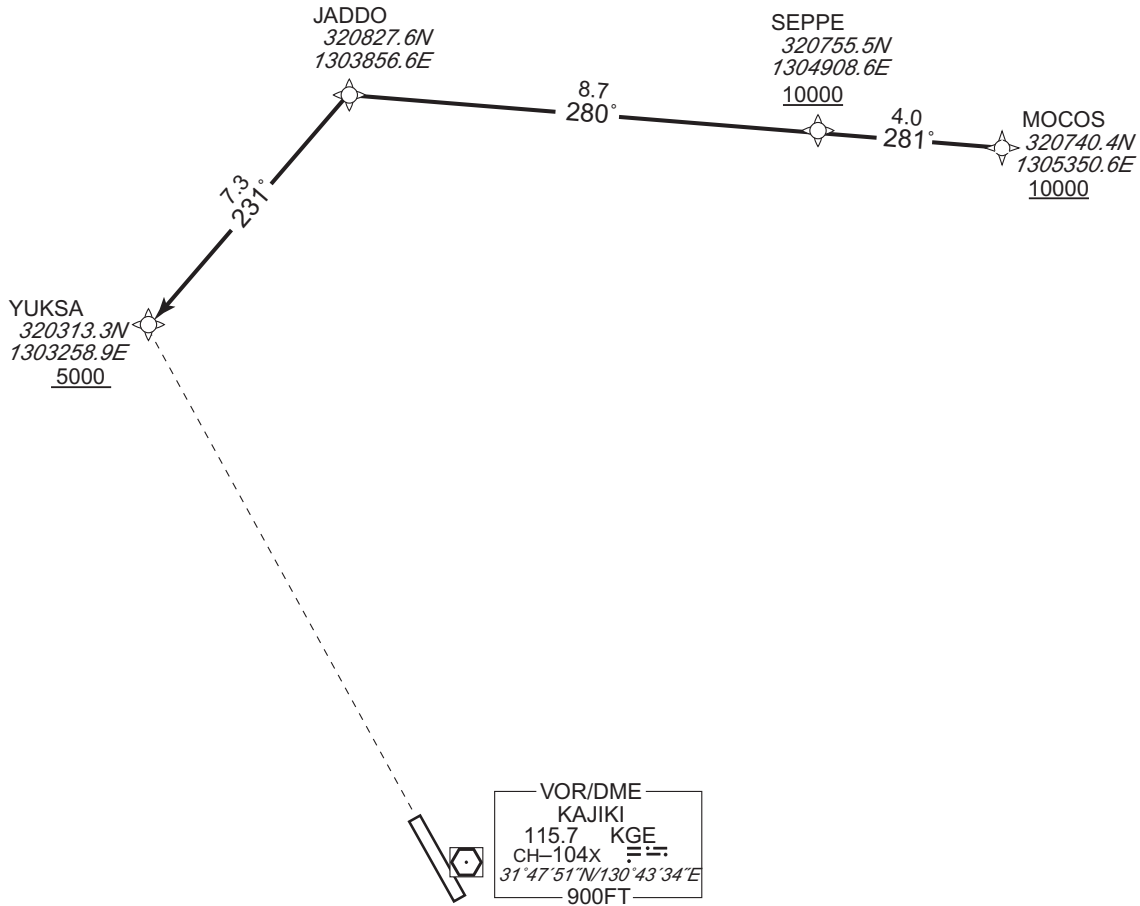

From MOCOS at or above 10000FT, to SEPPE at or above 10000FT, to JADDO, to YUKSA at or above 5000FT.

Critical DME	MZE	2NM to JADDO - JADDO
	KUE	1NM to YUKSA - YUKSA
	MZE	1NM to YUKSA - YUKSA
DME GAP	-	-
Inappropriate Navaids	See AD1.1.6.10.3. Inappropriate NAVAIDs for RNAV1	

CHANGE : Description of VAR and PROC name.

Serial Number	Path Descriptor	Waypoint Identifier	Fly Over	Course °M(°T)	Magnetic Variation	Distance (NM)	Turn Direction	Altitude (FT)	Speed (KIAS)	Vertical Angle	Navigation Specification
001	IF	MOCOS	-	-	-6.9	-	-	+10000	-	-	RNAV1
002	TF	SEPPE	-	281 (273.6)	-6.9	4.0	-	+10000	-	-	RNAV1
003	TF	JADDO	-	280 (273.6)	-6.9	8.7	-	-	-	-	RNAV1
004	TF	YUKSA	-	231 (224.0)	-6.9	7.3	-	+5000	-	-	RNAV1

STANDARD ARRIVAL CHART-INSTRUMENT

RJFK / KAGOSHIMA

RNAV STAR RWY16

OIDON ARRIVAL

RNAV 1

Note 1) DME/DME/IRU or GNSS required.  
2) RADAR service required.

VAR 7°W

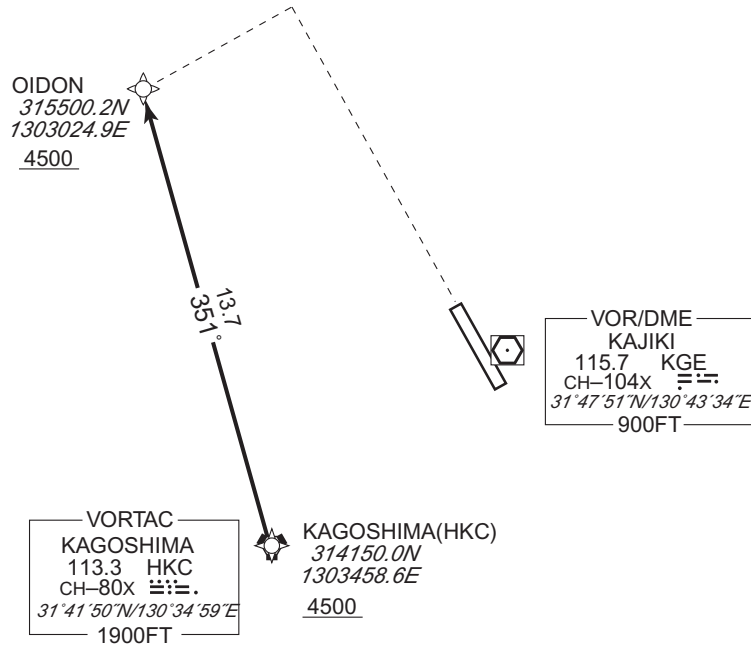

From HKC at or above 4500FT, to OI DON at or above 4500FT.

Critical DME	HKC	7NM to OI DON - OI DON
DME GAP	HKC - 10NM to OI DON	
Inappropriate NavAids	See AD1.1.6.10.3. Inappropriate NAVAIDs for RNAV1	

CHANGE : Description of VAR and PROC name.

Serial Number	Path Descriptor	Waypoint Identifier	Fly Over	Course °M(°T)	Magnetic Variation	Distance (NM)	Turn Direction	Altitude (FT)	Speed (KIAS)	Vertical Angle	Navigation Specification
001	IF	HKC	-	-	-6.9	-	-	+4500	-	-	RNAV1
002	TF	OI DON	-	351 (343.6)	-6.9	13.7	-	+4500	-	-	RNAV1

**INTENTIONALLY LEFT BLANK**

INSTRUMENT APPROACH CHART

RJFK / KAGOSHIMA

ILS Z or LOC Z RWY34

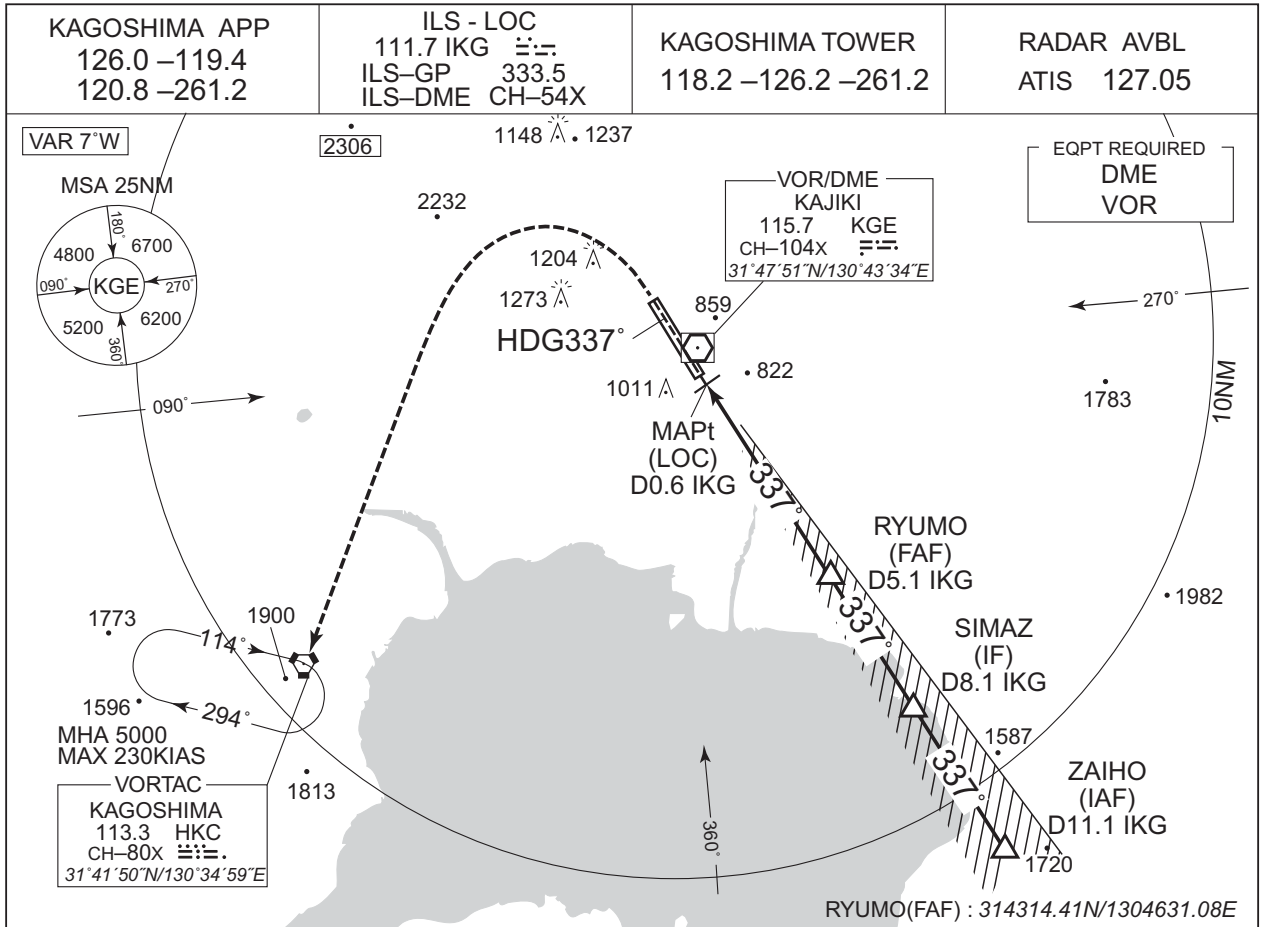

	NM to IKG	MAPt	2	3	4	5	FAF
	ALT (3.0° APCH Path)	-	1490	1809	2127	2446	2471

MISSED APPROACH

Climb to 1300FT on HDG337°,  
turn left, direct to HKC VORTAC  
and hold at 5000FT.  
Contact KAGOSHIMA APP.

No turn before IKG 0.6DME.  
Timing not authorized for defining the MAPt.

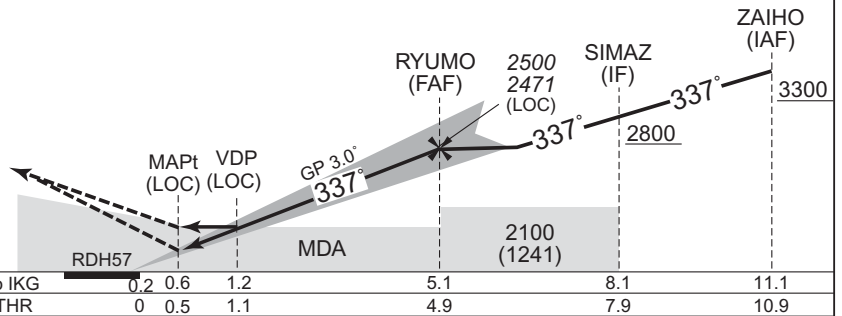

Missed APCH climb gradient MNM 5.0%

MINIMA THR elev. 859 AD elev. 891

CAT	CAT I		LOC		CIRCLING		
	DA(H)	RVR/CMV	MDA(H)	RVR/CMV	MDA(H)	VIS	
A	1059 (200)	550	1240 (381)	900	1680 (789)	1600	
B				1000			
C				1400			2400
D				1710 (819)			3200

MINIMA with Missed APCH climb gradient of 2.5% are not established.

CHANGE : MINIMA for circling. HLDG pattern.

INSTRUMENT APPROACH CHART

RJFK / KAGOSHIMA

ILS Y or LOC Y RWY34

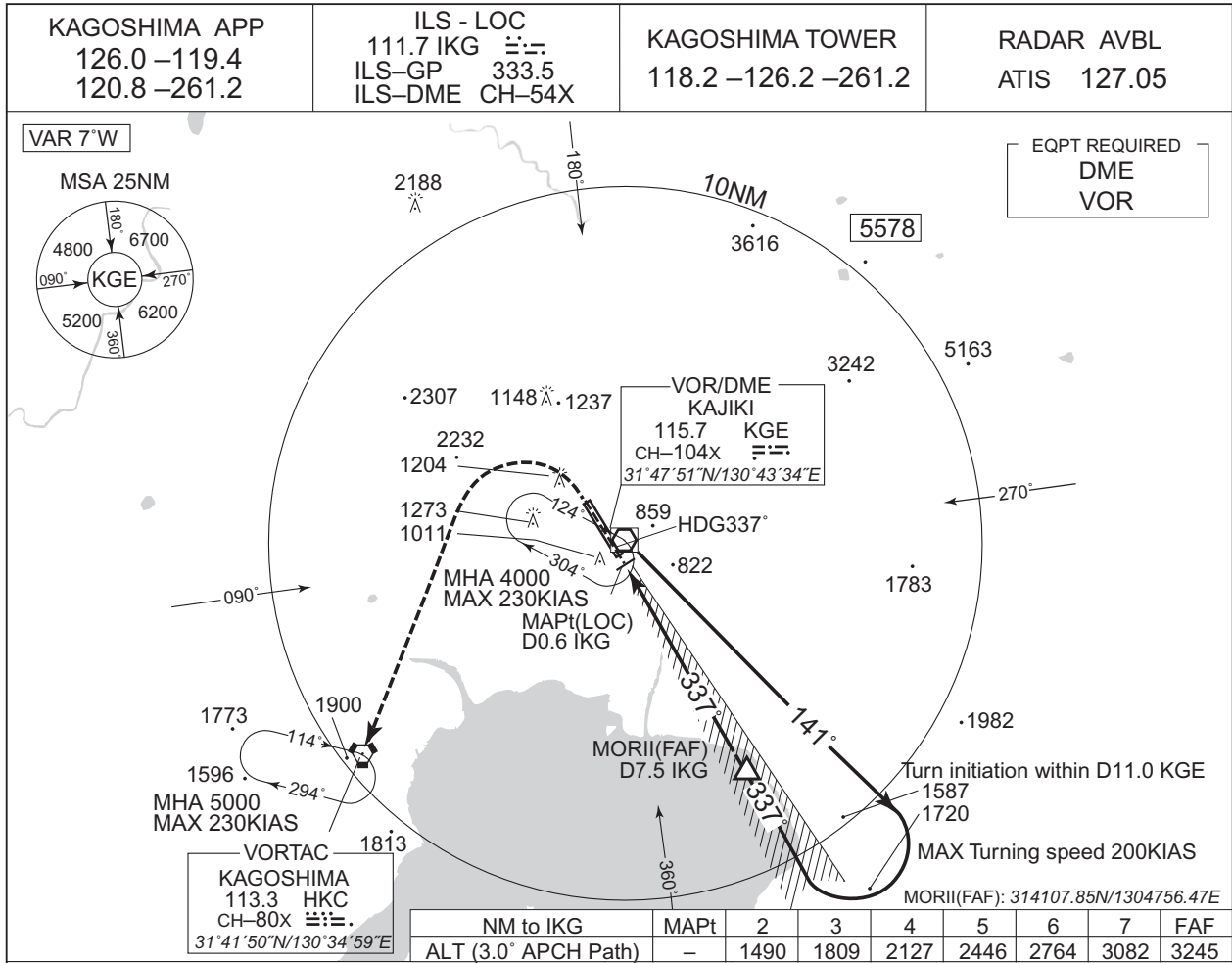

MISSED APPROACH

Climb to 1300FT on HDG337°,  
turn left, direct to HKC  
VORTAC and hold at 5000FT.  
Contact KAGOSHIMA APP.

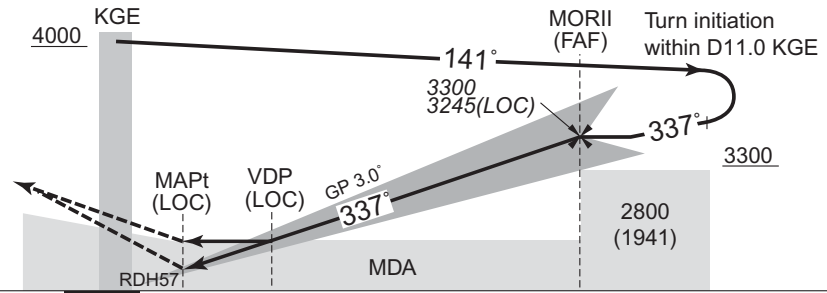

No turn before IKG 0.6DME.  
Timing not authorized for defining the MAPt.

DME to IKG	0.2	0.6	1.2	7.5
NM to THR	0	0.5	1.1	7.4

Missed APCH climb gradient MNM 5.0%.

MINIMA		THR elev. 859		AD elev. 891		
CAT	CAT I		LOC		CIRCLING	
	DA(H)	RVR/CMV	MDA(H)	RVR/CMV	MDA(H)	VIS
A	1059 (200)	550	1240 (381)	900	1680 (789)	1600
B				1000		2400
C				1400		3200
D						

MINIMA with Missed APCH climb gradient of 2.5% are not established.

CHANGE : MINIMA for circling. HLDG pattern.

INSTRUMENT APPROACH CHART

RJFK / KAGOSHIMA

VOR RWY34

<b>KAGOSHIMA APP</b> 126.0 –119.4 120.8 –261.2	<b>KAJIKI VOR/DME</b> 115.7 KGE CH-104X 31°47'51"N/130°43'34"E	<b>KAGOSHIMA TOWER</b> 118.2 –126.2 –261.2	<b>RADAR AVBL</b> ATIS 127.05
--	---	---	----------------------------------

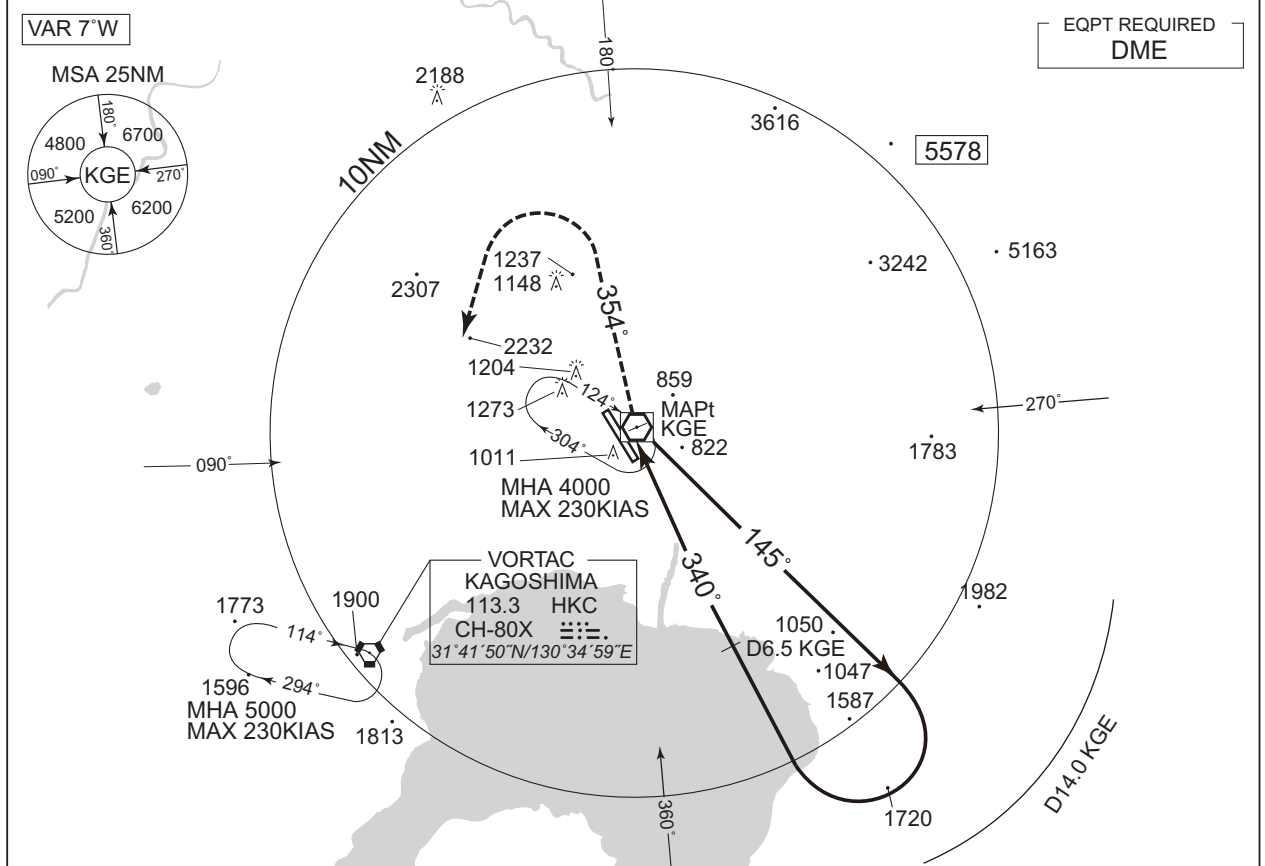

**MISSED APPROACH**  
 At KGE VOR/DME, turn right, climb via KGE R354 to 3500FT, turn left, direct to HKC VORTAC and hold at 5000FT. Contact KAGOSHIMA APP.

Remain within D14.0 KGE

The diagram shows a missed approach starting from a 4000ft altitude at KGE. A 145° turn leads to a 3300ft altitude. A 340° turn leads to a 2500ft altitude. The MAPt is at 859ft and the VDP is at 1.7 DME. The DME to KGE is 6.5.

CHANGE : MINIMA for circling. HLDG pattern.

MINIMA		THR elev. 859	AD elev. 891	
CAT			CIRCLING	
	MDA(H)	RVR/CMV	MDA(H)	VIS
A	1350 (491)	1000	1680 (789)	1600
B		1200		1710 (819)
C			1600	
D				

INSTRUMENT APPROACH CHART

RJFK / KAGOSHIMA

VOR A

KAGOSHIMA APP 126.0 -119.4 120.8 -261.2	KAJIKI VOR/DME 115.7 KGE $\equiv \equiv \equiv$ CH-104X 31°47'51"N/130°43'34"E	KAGOSHIMA TOWER 118.2 -126.2 -261.2	RADAR AVBL ATIS 127.05
---	---	--	---------------------------

VAR 7°W

EQPT REQUIRED  
DME

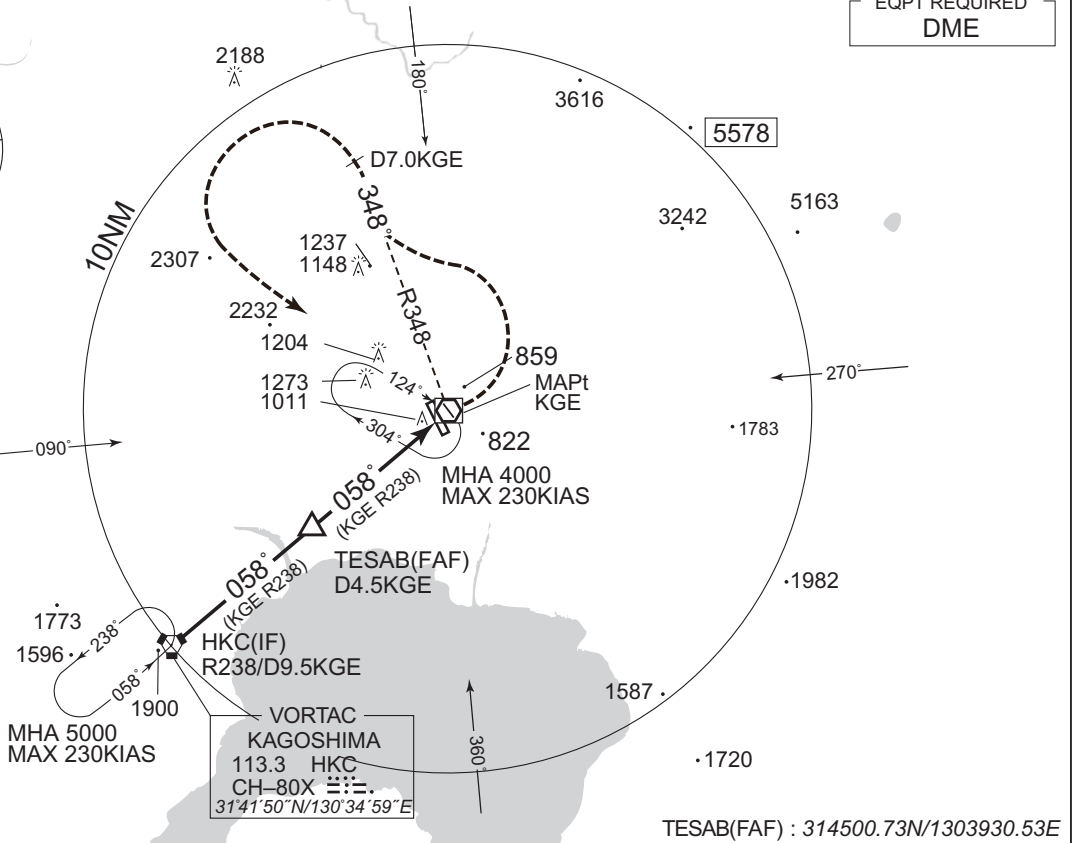
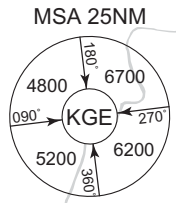

TESAB(FAF) : 314500.73N/1303930.53E

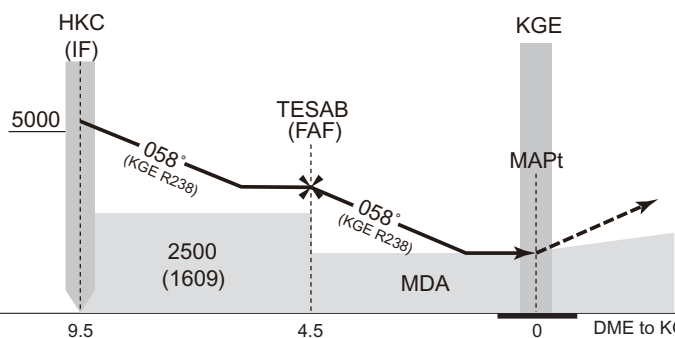

**MISSED APPROACH**  
Turn left, via KGE R348 to KGE 7.0DME,  
turn left, direct to KGE VOR/DME and  
hold at 4000FT.  
Contact KAGOSHIMA APP.

MINIMA		AD elev. 891
CAT	CIRCLING	
	MDA(H)	VIS
A	1680 (789)	1600
B		2400
C	1710 (819)	3200
D		

CHANGE : Missed APCH course. MINIMA. OCA(H) established. TESAB established. HLDG pattern.



INSTRUMENT APPROACH CHART

RJFK / KAGOSHIMA

RNP RWY34(LPV only)

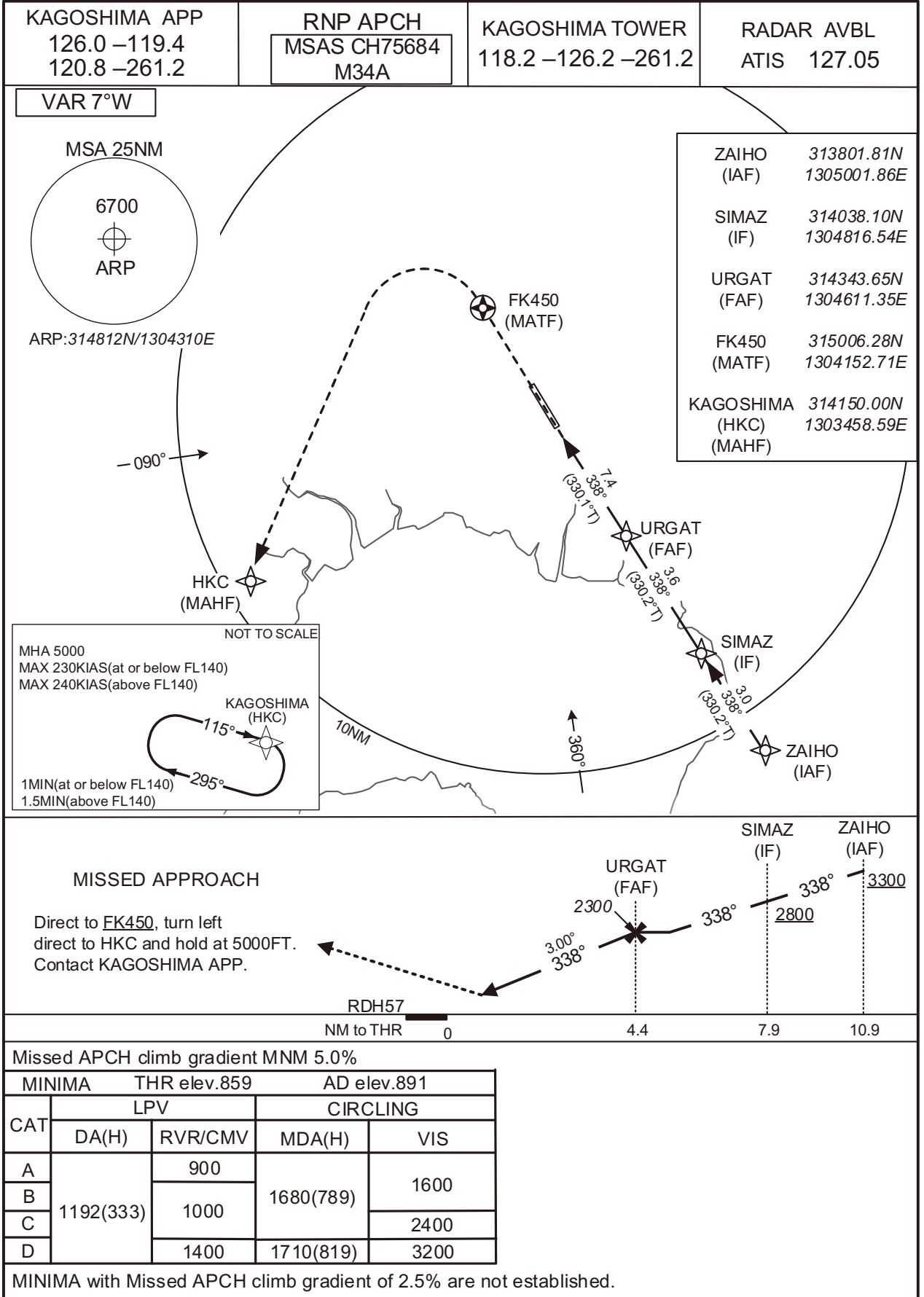

CHANGE : New PROC.

INSTRUMENT APPROACH CHART

RJFK / KAGOSHIMA

RNP RWY34(LPV only)

**FAS DATA BLOCK**

Operation type	0	LTP/FTP ellipsoidal height	+02939
SBAS service provider identifier	2	FPAP latitude	314854.3765N
Airport identifier	RJFK	FPAP longitude	1304241.3430E
Runway	34	Threshold crossing height	00017.3
Approach performance designator	0	TCH units selector	1
Route indicator		Glide path angle	03.00
Reference path data selector	0	Course width at threshold	105.00
Reference path ID	M34A	∠ length offset	0000
LTP/FTP latitude	314730.0345N	HAL	40.0
LTP/FTP longitude	1304338.3800E	VAL	50.0
CRC remainder	7F3AEA21		

**Required additional data**

LTP/FTP orthometric height	262.2
----------------------------	-------

CHANGE : New PROC.

INSTRUMENT APPROACH CHART

RJFK / KAGOSHIMA

RNP RWY16

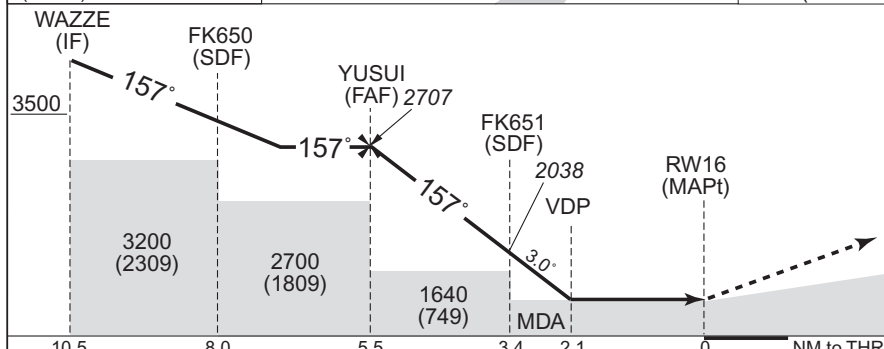
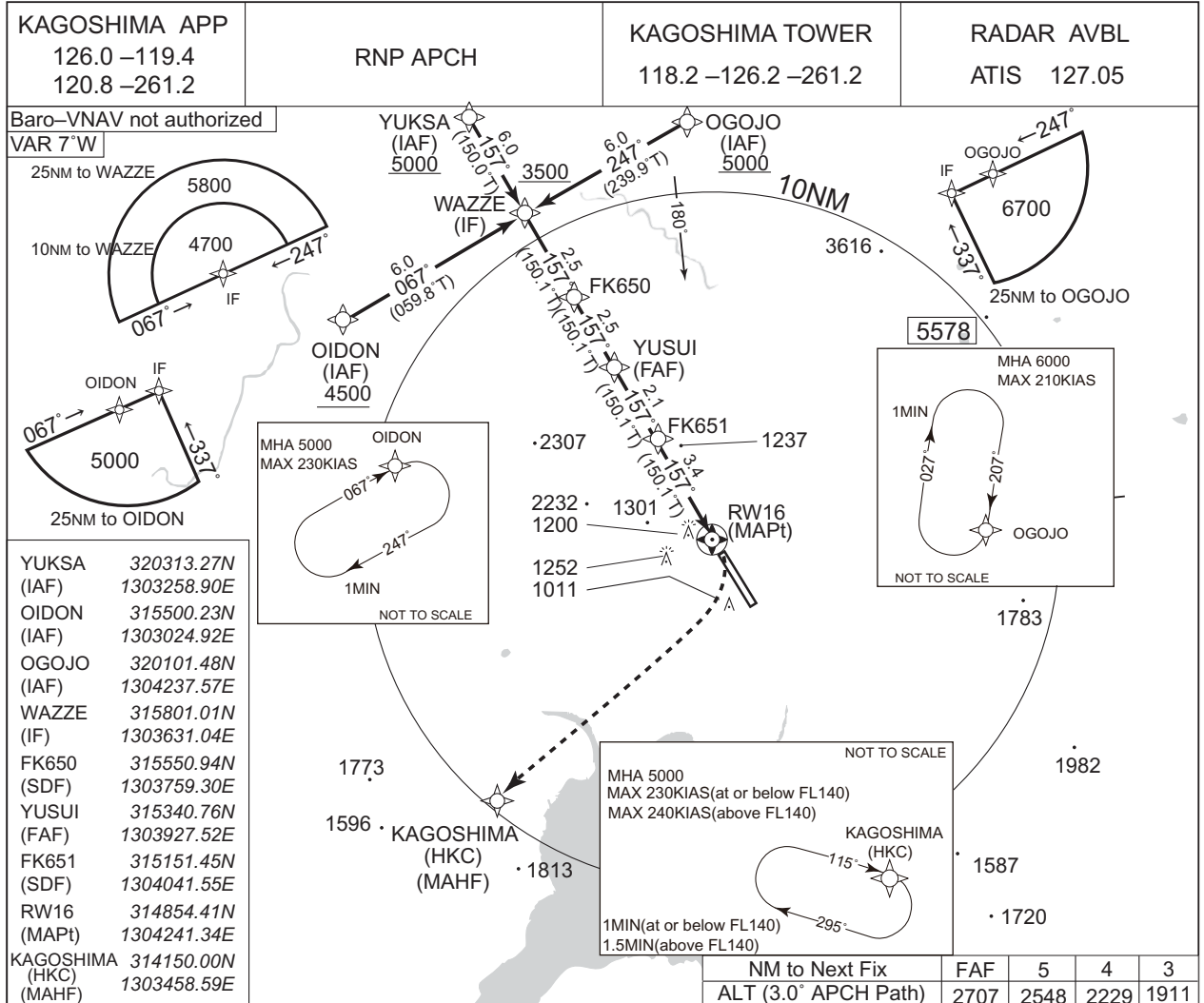

**MISSED APPROACH**  
Turn right direct to HKC and hold at 5000FT.  
Contact KAGOSHIMA APP.

CHANGE : MINIMA for circling.

	<b>MINIMA</b>	THR elev. 906	AD elev. 891			
	LNAV/VNAV	LNAV		CIRCLING		
CAT	DA(H)	CMV	MDA(H)	CMV	MDA(H) VIS	
A	Not applicable		1610 (719)	1500	1680 (789)	1600
B				1800		2400
C				2000	1710 (819)	3200
D						

**INTENTIONALLY LEFT BLANK**

RJFK / KAGOSHIMA

VISUAL APPROACH  
KINKO VISUAL RWY34

KAGOSHIMA APP 126.0 -119.4 120.8 -261.2	ILS - LOC 111.7 IKG $\equiv \equiv \equiv$ CH-54X ILS-GP 333.5	KAGOSHIMA TOWER 118.2 -126.2 -261.2	ATIS 127.05
---	---	--	-------------

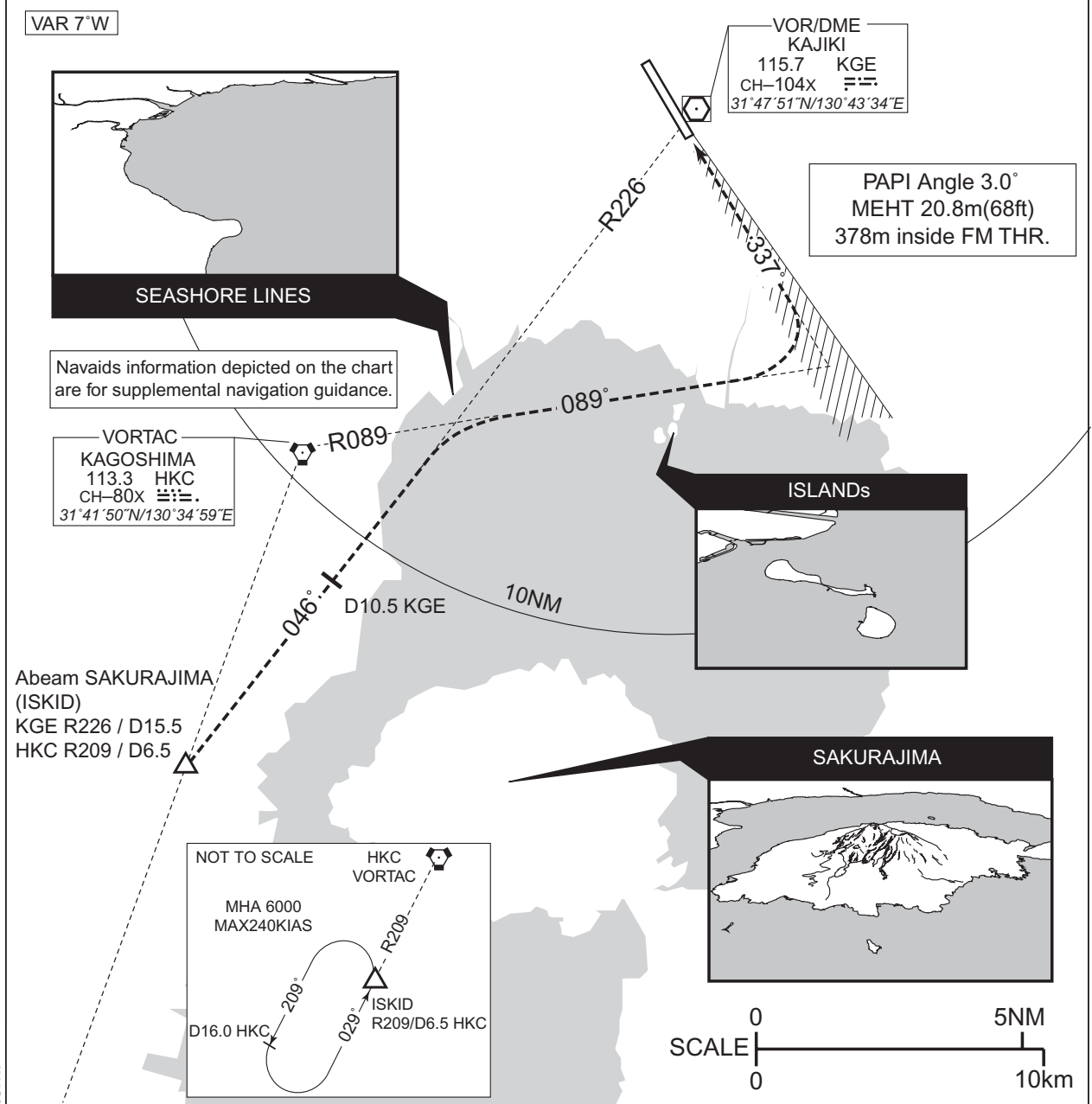

CHANGE : Radial FM HKC. HLDG pattern.

When visual approaches to RWY34 are in progress, arriving aircraft may be vectored into the ISKID for KINKO VISUAL RWY34 APPROACH.  
In the event of a go-around, climb via IKG LOC and RWY HDG to 3500FT until receiving ATC instructions.

<KINKO VISUAL RWY34 APPROACH>

After ISKID, aircraft proceed via seashore lines to the mouth of the Beppu River (KGE R226), proceed via seashore lines to ISLANDS(HKC R089) until intercept to RWY34 RWY center line, and proceed to RWY34(IKG LOC course).

Aircraft is recommended KGE 10.5DME(HKC R168) at or above 3500FT.

Note1: Pilot is urged to report promptly to ATC when lose sight of landmark(SAKURAJIMA, Seashore Lines and ISLANDS) and the preceding aircraft concerned.

Note2: Reference NAVAIDS(KGE, HKC and IKG LOC) must be operating.

Note3: RADAR service required.

Note4: Procedure not authorized at night.

RJFK / KAGOSHIMA

Visual REP

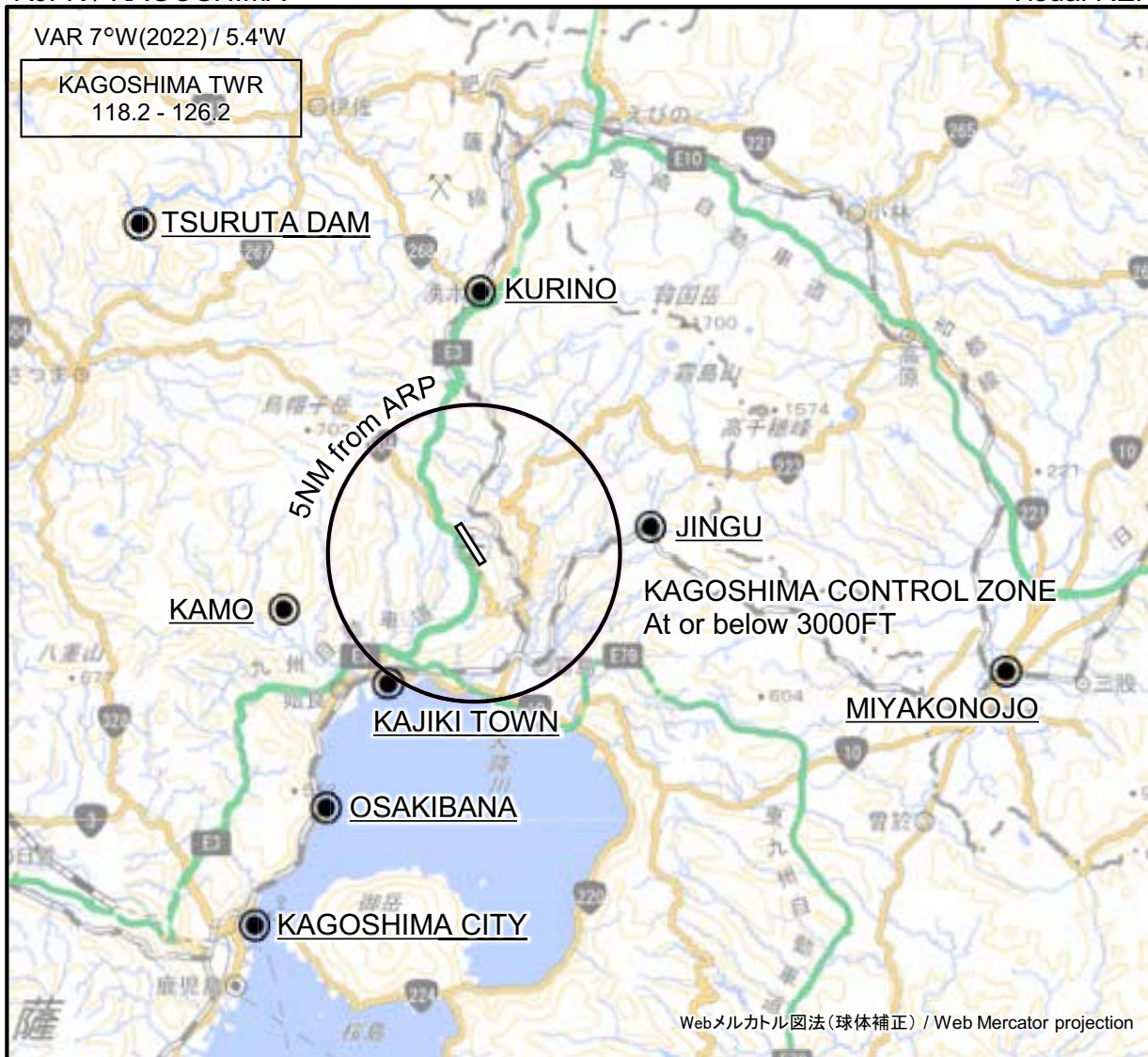

※図中に標高を示す数字がある場合、単位はメートル(m)である。The unit of measurement used to express elevation is meter(m).

CHANGE : Map updated. BRG/DIST from ARP.

Call sign	BRG / DIST from ARP	Remarks
鶴田ダム Tsuruta Dam	314°T / 16.0NM	ダム Dam
栗野 Kurino	001°T / 8.8NM	JR駅 JR Station
神宮 Jingu	081°T / 6.1NM	JR駅 JR Station
蒲生 Kamo	254°T / 6.8NM	住吉池 Pond
都城 Miyakonojo	102°T / 18.6NM	JR駅 JR Station
加治木タウン Kajiki Town	214°T / 5.3NM	網掛川河口 River mouth (The Amikake)
大崎鼻 Osakibana	211°T / 10.0NM	崎 Point
鹿児島シティ Kagoshima City	211°T / 14.7NM	港 Harbor

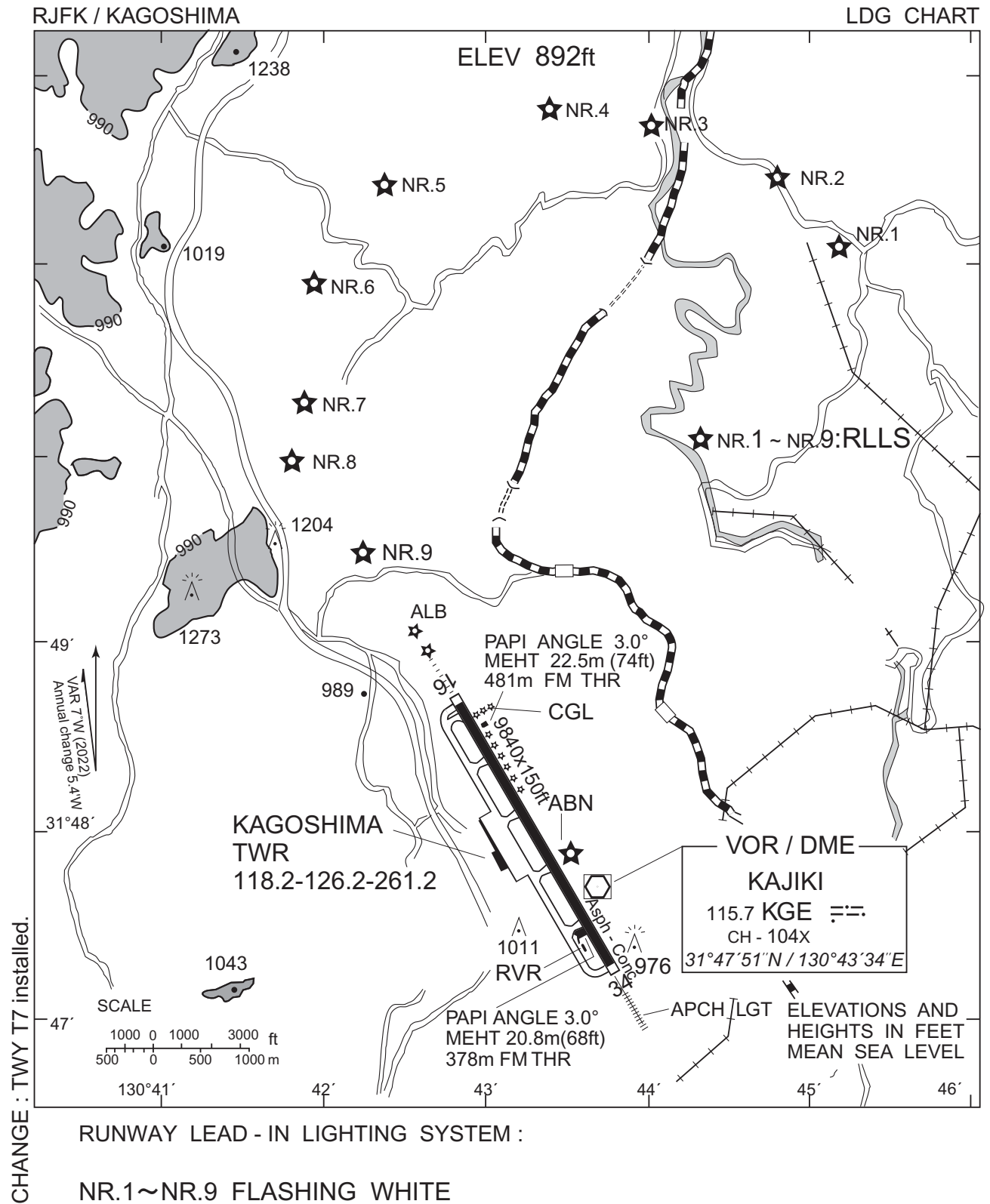

RJFK / KAGOSHIMA

Minimum Vectoring Altitude CHART

VAR 6°W (2008)

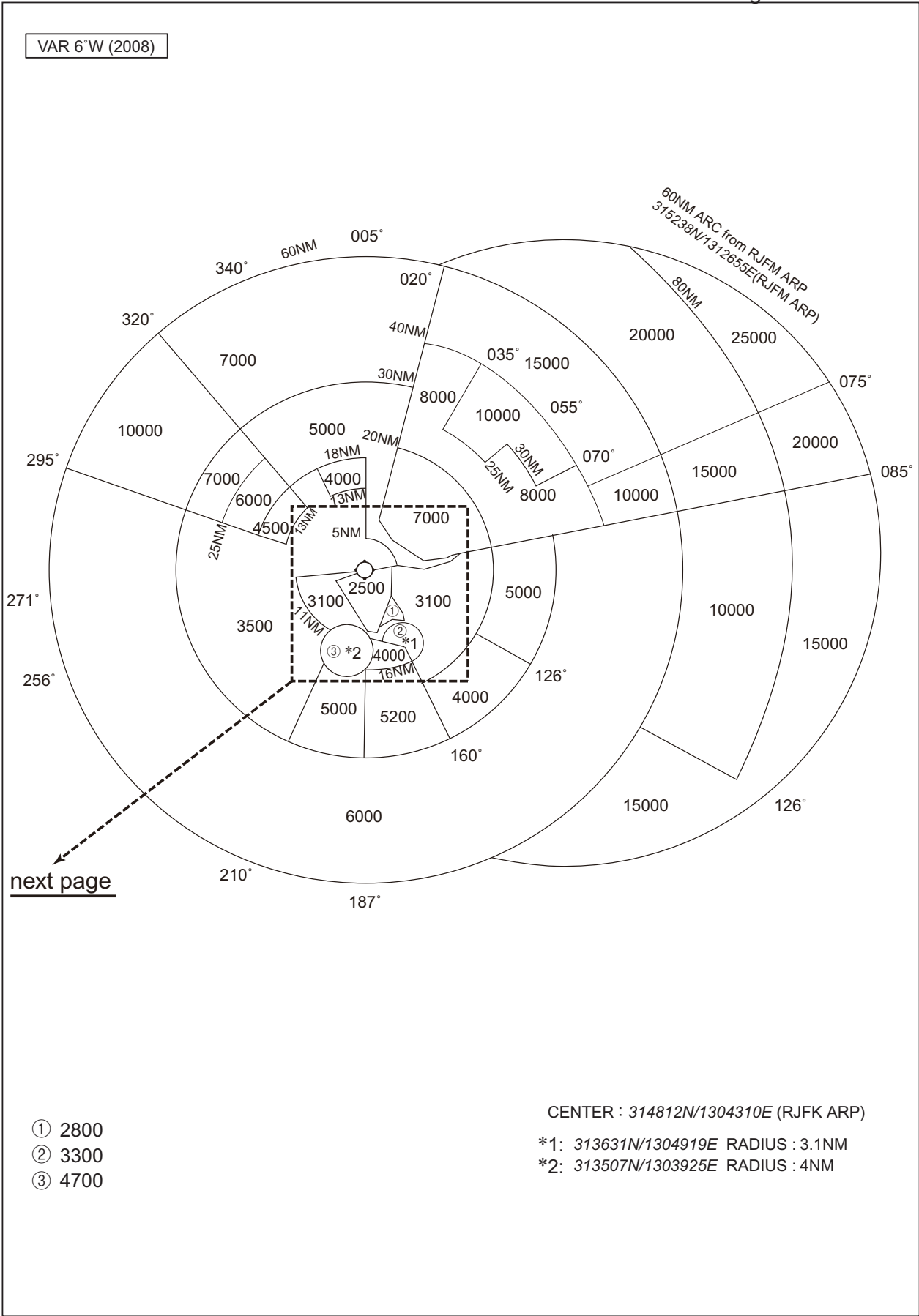

CHANGE : Update



RJFK / KAGOSHIMA

Minimum Vectoring Altitude CHART

enlarged view

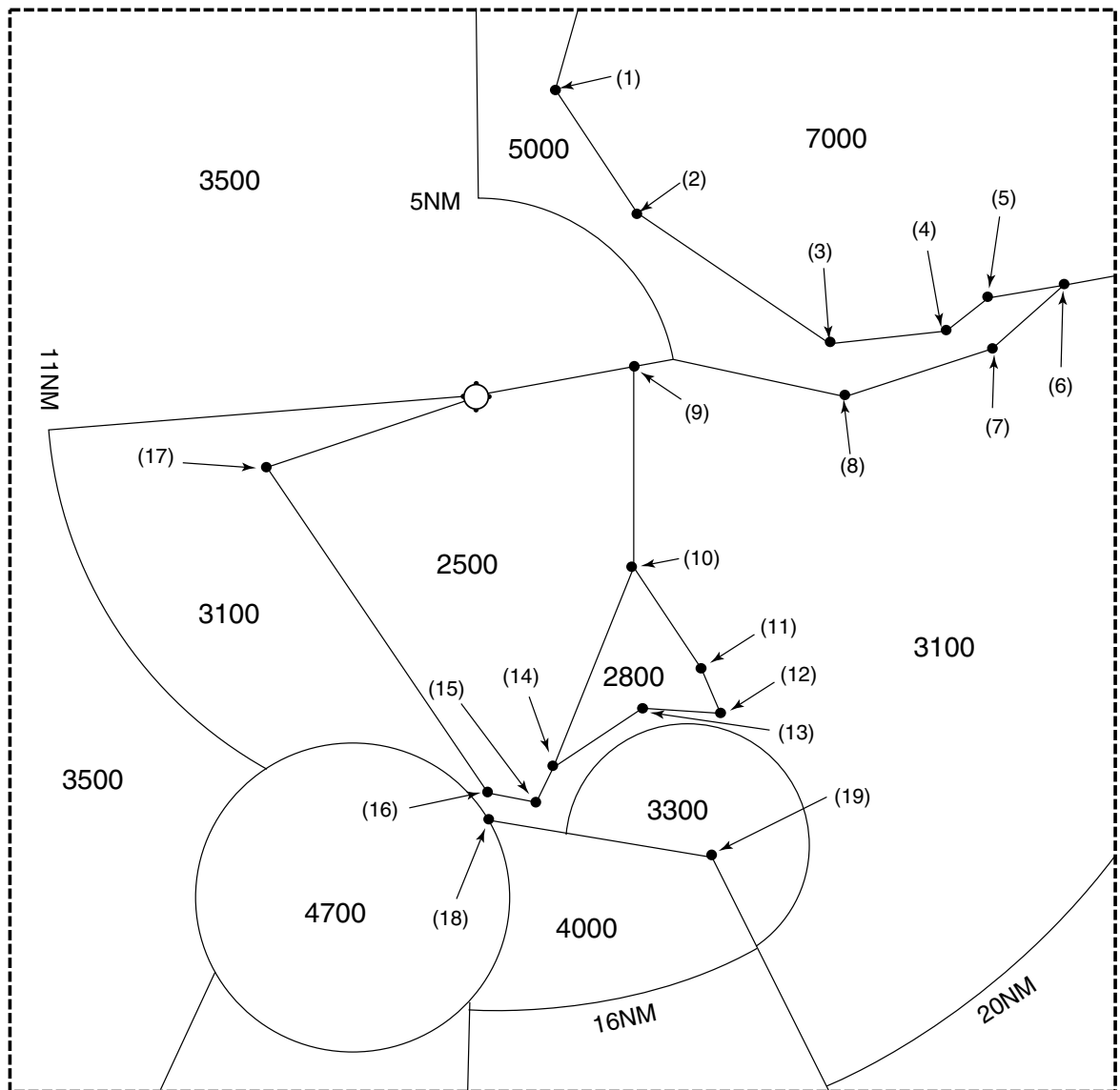

- |                         |                         |
|-------------------------|-------------------------|
| ( 1 ) 315600N/1304528E  | ( 11 ) 314059N/1304947E |
| ( 2 ) 315250N/1304805E  | ( 12 ) 314004N/1305007E |
| ( 3 ) 314927N/1305345E  | ( 13 ) 314005N/1304809E |
| ( 4 ) 314951N/1305709E  | ( 14 ) 313829N/1304518E |
| ( 5 ) 315042N/1305825E  | ( 15 ) 313733N/1304453E |
| ( 6 ) 315102N/1310029E  | ( 16 ) 313747N/1304326E |
| ( 7 ) 314919N/1305824E  | ( 17 ) 314616N/1303653E |
| ( 8 ) 314801N/1305359E  | ( 18 ) 313707N/1304328E |
| ( 9 ) 314858N/1304746E  | ( 19 ) 313608N/1305004E |
| ( 10 ) 314342N/1304742E |                         |