

AD 2 AERODROMES

RJFO AD 2.1 AERODROME LOCATION INDICATOR AND NAME

RJFO - OITA

RJFO AD 2.2 AERODROME GEOGRAPHICAL AND ADMINISTRATIVE DATA

1	ARP coordinates and site at AD	332846N/1314414E 007 Degrees /1.5KM FM RWY 01 THR
2	Direction and distance from (city)	16NM NE FM OITA City
3	Elevation/ Reference temperature	17FT / 30°C
4	Geoid undulation at AD ELEV PSN	104FT
5	MAG VAR/ Annual change	7°W(2009) / 2'W
6	AD Administration, address, telephone, telefax, telex, AFS, e-mail and/or Web-site addresses	JCAB Aza Omida, Itoharu, Musashi-machi, Kunisaki-shi, Oita Pref. 873-0421 JAPAN. Tel:0978(67)3771, 0978(67)3773 Fax:0978(67)3780, 0978(67)3781(AIS) AFS:RJFOYFYX
7	Types of traffic permitted (IFR/VFR)	IFR/VFR
8	Remarks	Nil

RJFO AD 2.3 OPERATIONAL HOURS

1	AD Administration	2230 - 1330
2	Customs and immigration	Customs:2330-0815 Immigration:INTL SKED FLT hours only
3	Health and sanitation	INTL SKED FLT hours only
4	AIS Briefing Office	2230 - 1330
5	ATS Reporting Office(ARO)	Nil
6	MET Briefing Office	H24 (FUKUOKA)
7	ATS	2230 - 1330
8	Fuelling	2230 - 1330
9	Handling	2230 - 1330
10	Security	2230 - 1330
11	De-icing	Nil
12	Remarks	Nil

RJFO AD 2.4 HANDLING SERVICES AND FACILITIES

1	Cargo-handling facilities	All the modern institutions that with the weight thing to Boeing 747 type freighter.
2	Fuel/ oil types	JET A-1
3	Fuelling facilities/ capacity	Fuel Truck / Not Limitation
4	De-icing facilities	Nil
5	Hangar space for visiting aircraft	Nil
6	Repair facilities for visiting aircraft	Nil
7	Remarks	Nil

RJFO AD 2.5 PASSENGER FACILITIES

1	Hotels	Near FM Airport
2	Restaurants	At Airport
3	Transportation	Buses and Taxis
4	Medical facilities	Hospital in Aki-town 3km
5	Bank and Post Office	BANK ATM at Airport
6	Tourist Office	At Airport
7	Remarks	Nil

RJFO AD 2.6 RESCUE AND FIRE FIGHTING SERVICES

1	AD category for fire fighting	CAT 9
2	Rescue equipment	Chemical fire fighting truck x 3 Water-supply truck Lighting power supply truck Emergency medical equipments conveyance truck
3	Capability for removal of disabled aircraft	Ask AD Administration
4	Remarks	Nil

RJFO AD 2.7 SEASONAL AVAILABILITY-CLEARING

1	Types of clearing equipment	Clearing equipments: Sweeper x 1 Snow removal equipments: NIL(commission)
2	Clearance priorities	(1) RWY, TWY T0 T6 P, Spot 7-9 (2) TWY T1 T5, Spot 5-6 (3) TWY T2 T3 T4, Spot 1-3 10 11
3	Remarks	Snow removal will be commenced when the RWY and TWY are covered with snow its depth 3cm or more(Ask AD administration for details)

RJFO AD 2.8 APRONS, TAXIWAYS AND CHECK LOCATIONS DATA

1	Apron surface and strength	Surface: Asphalt-concrete and concrete Strength : Spot NR1A, 1B, 2, 3 : PCN 55/F/C/X/T Spot NR5, 6 : PCN 53/R/B/X/T Spot NR7, 8, 9, 10 : PCN 62/R/B/X/T Spot NR11 : PCN 74/R/B/X/T
2	Taxiway width, surface and strength	Surface: Asphalt-concrete and concrete Strength : TWY T0, P0, P3, P4: PCN 80/F/B/X/T TWY T1: PCN 91/F/C/X/T TWY T2, T4, P1: PCN 88/F/C/X/T TWY T3: PCN 101/F/C/X/T TWY T5, P5: PCN 76/F/B/X/T TWY T6: PCN 72/F/B/X/T TWY P2: PCN 74/R/B/X/T Width: TWY T1, T2, T3, T4, T5: 34m TWY T0, T6: 28.5m TWY P0, P1, P2, P3, P4, P5: 23m
3	ACL and elevation	Not Available
4	VOR checkpoints	Not Available
5	INS checkpoints	(Spot NR) 2 : 332844.43N,1314403.07E 3 : 332842.98N,1314403.05E 5 : 332841.51N,1314403.02E 6 : 332840.05N,1314403.01E 7 : 332837.39N,1314359.83E 8 : 332835.12N,1314359.81E 9 : 332832.85N,1314359.79E 10 : 332830.58N,1314359.77E 11 : 332828.47N,1314359.71E
6	Remarks	Nil

RJFO AD 2.9 SURFACE MOVEMENT GUIDANCE AND CONTROL SYSTEM AND MARKINGS

1	Use of aircraft stand ID signs, TWY guide lines and Visual docking/ parking guidance system of aircraft stands	ACFT stand ID signs: Spot 1-11
2	RWY and TWY markings and LGT	RWY:RWY01/19(SEE RJFO AD2.24) (Marking) RWY designation, RWY CL, RWY THR, RWY middle point, Aiming point, TDZ, RWY side stripe (LGT) RCLL, REDL, RTHL, RENL, RTZL(RWY01), WBAR(RWY01) TWY:ALL TWY (Marking) TWY CL, RWY HLDG PSN, TWY side stripe (LGT) TWY edge LGT, TWY CL LGT, RWY guard LGT, Taxiing guidance sign
3	Stop bars	Nil
4	Remarks	(Marking) Overrun area (LGT) Apron flood LGT

RJFO AD 2.10 AERODROME OBSTACLES

- In Area2 See Obstacle data
- In Area3 To be developed

RJFO AD 2.11 METEOROLOGICAL INFORMATION PROVIDED

1	Associated MET Office	FUKUOKA
2	Hours of service MET Office outside hours	H24 (FUKUOKA)
3	Office responsible for TAF preparation Periods of validity	FUKUOKA 30 Hours
4	Trend forecast Interval of issuance	Nil
5	Briefing/ consultation provided	Briefing is available upon inquiry at FUKUOKA
6	Flight documentation Language(s) used	C En
7	Charts and other information available for briefing or consultation	S ₆ , U ₈₅ , U ₇ , U ₅ , U ₃ , U ₂₅ , U ₂ /Tr, P _S , P ₅ , P ₃ , P ₂₅ , P _{SWE} , P _{SWF} , P _{SWG} , P _{SWI} , P _{SWM} , P _{SW(domestic)} , E, C, W _E , W _F , W _G , W _I , W, N
8	Supplementary equipment available for providing information	Nil
9	ATS units provided with information	TWR, APP, ATIS
10	Additional information(limitation of service, etc.)	Nil

RJFO AD 2.12 RUNWAY PHYSICAL CHARACTERISTICS

Designations RWY NR	TRUE BRG	Dimensions of RWY(M)	Strength(PCN) and surface of RWY	THR coordinates THR geoid undulation	THR elevation and highest elevation of TDZ of precision APP RWY
1	2	3	4	5	6
01	000°	3000x45	PCN 98/F/C/X/T Asphalt-Concrete	332757.53N 1314413.22E 104FT	THR ELEV:19FT TDZ ELEV:19FT
19	180°	3000x45	PCN 98/F/C/X/T Asphalt-Concrete	332934.89N 1314414.08E 104FT	THR ELEV:17FT
Slope of RWY	Strip Dimensions(M)	RESA (Overrun) Dimensions (M)	Remarks		
7	10	11	14		
See AD CHART	3120x300 3120x300	190x(MNM:152 MAX:300)* 40x300	RWY Grooving 3000m x 30m		
*For detail, ask airport administrator					

RJFO AD 2.13 DECLARED DISTANCES

RWY Designator	TORA (m)	TODA (m)	ASDA (m)	LDA (m)	Remarks
1	2	3	4	5	6
01	3000	3000	3000	3000	Nil
19	3000	3000	3000	3000	Nil

RJFO AD 2.14 APPROACH AND RUNWAY LIGHTING

RWY Designator	APCH LGT type LEN INTST	RTHL Color WBAR	PAPI (VASIS) Angle DIST FM THR MEHT	RTZL LEN	RCLL LEN Spacing Color INTST	REDL LEN Spacing Color INTST	RENL Color WBAR	STWL LEN Color
1	2	3	4	5	6	7	8	9
01	PALS (CAT I) 900M LIH	Green Green	PAPI 3.0°/LEFT 413M 66FT	900M	3000M 30M Coded color (White/Red) LIH	3000M 60M Coded color (White/Yellow) LIH	Red	Nil (*2)
19	SALS (*1) 420M LIH	Green -	PAPI 3.0°/LEFT 457M 74FT	Nil	3000M 30M Coded color (White/Red) LIH	3000M 60M Coded color (White/Yellow) LIH	Red	Nil (*2)
Remarks								
10								
SALS with APCH LGT beacon(600m and 900m FM RWY THR)(*1) Overrun area edge LGT(LEN:60m Color:Red)(*2) CGL for RWY 19								

RJFO AD 2.15 OTHER LIGHTING, SECONDARY POWER SUPPLY

1	ABN/IBN location, characteristics and hours of operation	ABN: 332833N/1314353E, White/Green EV4.3sec, HO Operating in night, IMC, and when requested
2	LDI location and LGT Anemometer location and LGT	LDI:Nil Anemometer: RWY01: 355m from RWY 01 THR, LGTD RWY19: 300m from RWY 19 THR, LGTD
3	TWY edge and center line lighting	TWY edge and center line lights installed, see AD2.9
4	Secondary power supply / switch-over time	Within 1 sec : REDL, RENL, RTHL, WBAR, RCLL, Overrun area edge LGT Within 15 sec : Other LGT
5	Remarks	WDI LGT

RJFO AD 2.16 HELICOPTER LANDING AREA

Nil

RJFO AD 2.17 ATS AIRSPACE

Designation and lateral limits		Vertical limits (ft)	Airspace classification	ATS unit call sign Language	Remarks
1		2	3	4	6
OITA CTR	Area within a radius of 5nm of OITA ARP	3000 or below	D	OITA TOWER	
OITA ACA	SEE RJFO ATTACHED CHART				

大分進入管制区
Oita Approach Control Area

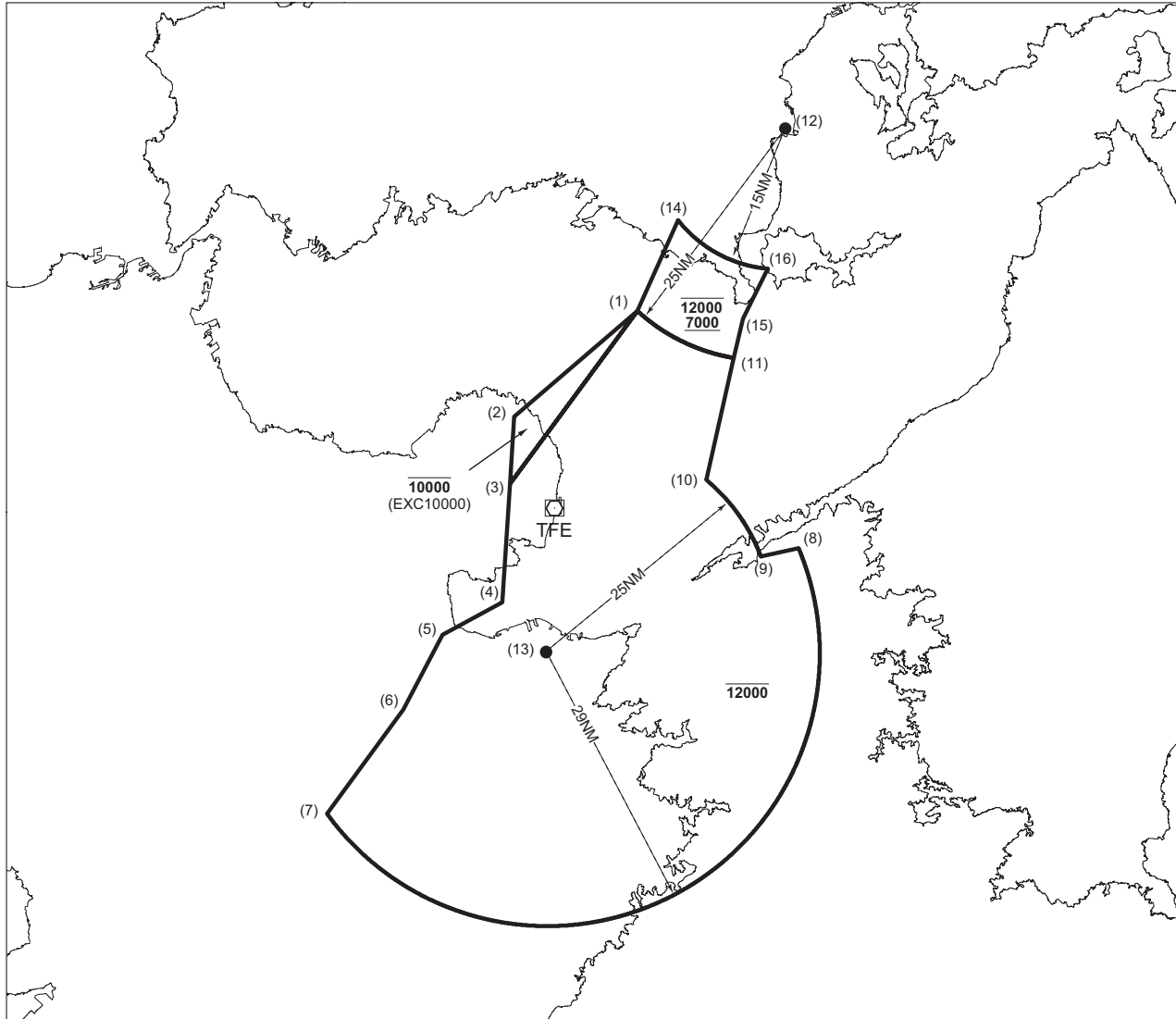

Point list

- | | |
|----------------------|----------------------|
| (1) 334923N1315428E | (11) 334410N1320642E |
| (2) 333820N1313835E | (12) 340827N1321357E |
| (3) 333112N1313754E | (13) 331313N1314212E |
| (4) 331835N1313643E | (14) 335858N1315956E |
| (5) 331513N1312903E | (15) 334822N1320757E |
| (6) 330719N1312355E | (16) 335336N1321117E |
| (7) 325619N1311408E | |
| (8) 332346N1321425E | |
| (9) 332258N1320939E | |
| (10) 333116N1320253E | |

RJFO AD 2.18 ATS COMMUNICATION FACILITIES

Service designation	Call sign	Frequency	Hours of operation	Remarks
1	2	3	4	5
APP	Oita Approach	120.6MHz(1) 127.7MHz 119.05MHz 261.2MHz 121.5MHz(E) 243.0MHz(E)	2230 - 1330	(1)Primary
ASR	Oita Radar	119.05MHz 120.6MHz 127.7MHz 261.2MHz 121.5MHz(E) 243.0MHz(E)	2230 - 1330	
DEP	Oita Departure	127.7MHz 120.6MHz 119.05MHz 261.2MHz 121.5MHz(E) 243.0MHz(E)	2230 - 1330	
TWR	Oita Tower	118.8MHz(1) 126.2MHz 261.2MHz 121.5MHz(E) 243.0MHz(E)	2230 - 1330	
GND	Oita Ground	121.6MHz	2230 - 1330	
ATIS	Oita Airport	127.8MHz	2230 - 1330	

RJFO AD 2.19 RADIO NAVIGATION AND LANDING AIDS

Type of aid (VOR declination)	ID	Frequency	Hours of operation	Position of transmitting antenna coordinates	Elevation of DME transmitting antenna	Remarks
1	2	3	4	5	6	7
ILS-LOC 01	ITF	111.5MHz	2230 - 1330	332942.19N/ 1314414.15E		LOC:225m(738ft) away FM RWY19 THR, BRG(MAG)007°. Unusable beyond 16nm.
ILS-GP 01	-	332.9MHz	2230 - 1330	332807.70N/ 1314417.95E		GP:315m (1034ft) inside FM RWY 01 THR,120m(394ft) E of RCL. HGT of ILS Ref datum16.5m (54ft) GP angle 3.0°.
ILS-DME 01	ITF	1013MHz (CH-52X)	2230 - 1330	332808.01N/ 1314418.31E	37ft	DME: 325m(1066ft) inside FM RWY 01 THR, 130m(427ft) E of RCL.
VOR (7°W/2016)	TFE	117.7MHz	H24	332922.97N/ 1314343.52E		VOR Unusable: 210°-220° beyond 35NM below 8,000FT. 240°-260° beyond 35NM below 8,000FT. 270°-330° beyond 30NM below 6,000FT.
DME	TFE	1211MHz (CH-124X)	H24	332922.97N/ 1314343.52E	100ft	DME Unusable: 260°-270° beyond 35NM below 8,000FT. 270°-290° beyond 15NM below 6,000FT. 290°-330° beyond 30NM below 6,000FT. 330°-340° beyond 30NM below 5,000FT.
MSAS		1575.42MHz	H24			Transmitting antennas are satellite based.

RJFO / OITA

ILS

ILS

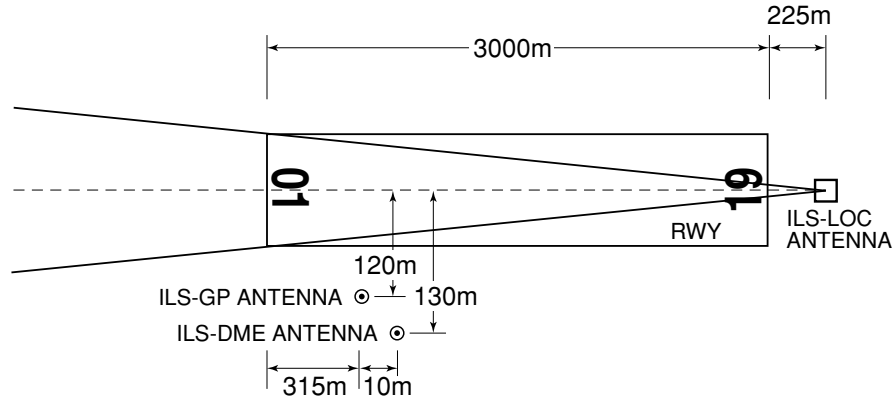

REMARKS : 1. LOC beam BRG(MAG) 007°
 2. HGT of ILS REF datum 16.5m(54ft)
 3. GP angle 3.0°
 4. ELEV of ILS-DME 11.2m(37ft)

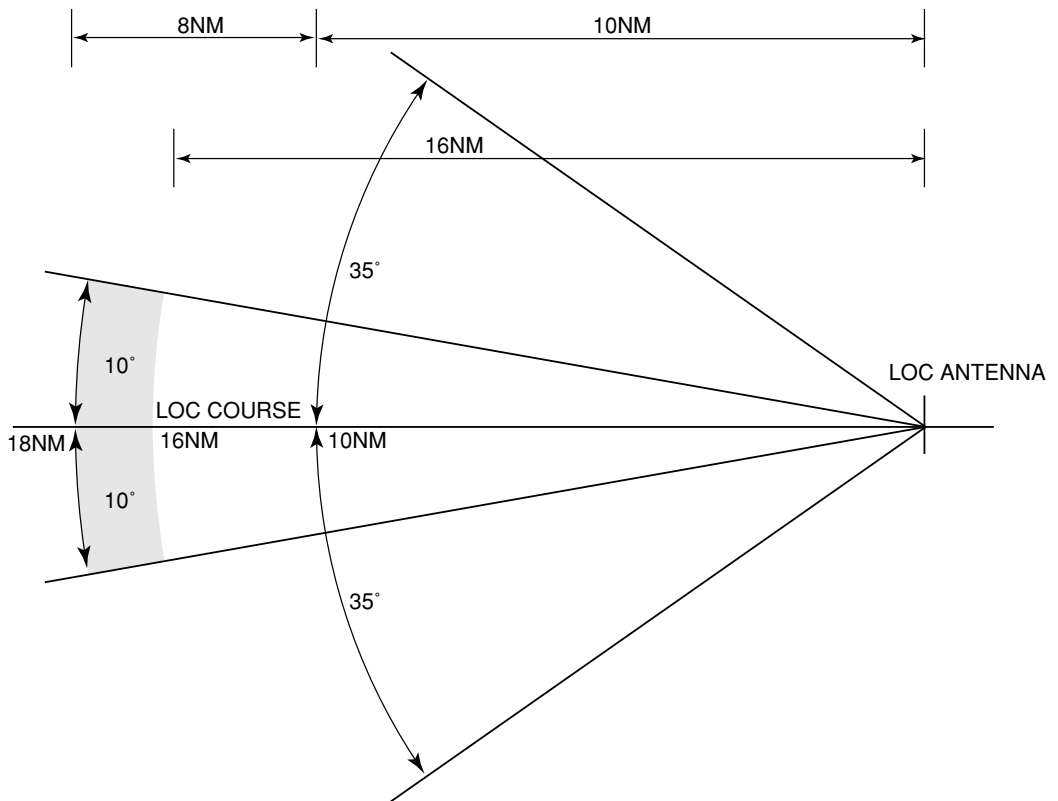

LOC UNUSABLE : BEYOND 16NM.

RJFO AD 2.20 LOCAL TRAFFIC REGULATIONS

1. Airport regulations

On use of this airport by transient ACFT, the operator is required to obtain the prior permission of the airport administrator in order to adjust of parking area, except scheduled flight and ACFT in an emergency.

2. Taxiing to and from stands

Nil

3. Parking area for small aircraft(General aviation)

Nil

4. Parking area for helicopters

Nil

5. Apron - taxiing during winter conditions

Nil

6. Taxiing - limitations

Nil

7. School and training flights - technical test flights - use of runways

Nil

8. Helicopter traffic - limitation

Nil

9. Removal of disabled aircraft from runways

Nil

RJFO AD 2.21 NOISE ABATEMENT PROCEDURES

Nil

RJFO AD 2.22 FLIGHT PROCEDURES

1. TAKE OFF MINIMA

	RWY	ACFT CAT	REDL & RCLL		REDL or RCLL or RCL marking		NIL (DAYTIME ONLY)	
			RVR	VIS	RVR	VIS	RVR	VIS
Multi-Engine ACFT with TKOF ALTN AP Filed	01	A,B,C,D	400	400	400	400	-	500
	19	A,B,C,D	-	400	-	400	-	500
OTHER	01	A,B,C,D	AVBL LDG MINIMA					
	19	A,B,C,D						

2. Lost Communication Procedures for Arrival Aircraft under radar navigational guidance

If radio Communications with Oita Approach/Radar are lost for 30 seconds,
squawk Mode A/3 Code 7600 and;

- I
 - 1. Contact Oita Tower.
 - 2. If unable, proceed in accordance with Visual Flight Rules.
 - 3. If unable, proceed to Musashi VOR/DME at last assigned altitude or 3500 feet whichever is higher and execute Instrument Approach.
- II Procedures other than above will be issued when situation required.

3. Trajectorized Airport Traffic Data Processing System (TAPS)

Aircraft flying in Oita approach control area under its control will be instructed to reply with discrete code on Mode A/3 and Mode C.

If an aircraft has no capability of replying with discrete code, the pilot shall report ATC if so instructed.

大分アプローチの指示のもとに、当該進入管制区を飛行する航空機は、モード A/3 の二次レーダー個別コード及びモード C による応答を指示される。
二次レーダー個別コードを搭載していない航空機が当該コードによる応答を指示された場合は、管制機関に対しその旨通報すること。

RJFO AD 2.23 ADDITIONAL INFORMATION

Nil

RJFO AD 2.24 CHARTS RELATED TO AN AERODROME

Aerodrome Chart
Aerodrome Obstacle Chart-ICAO type A (RWY01/19)
Aerodrome Obstacle Chart-ICAO type B
Standard Departure Chart-Instrument (MUSASHI)
Standard Departure Chart-Instrument (EBOSHI-RNAV)
Standard Departure Chart-Instrument (TOYO-RNAV)
Standard Departure Chart-Instrument (FUSHA-RNAV)
Standard Departure Chart-Instrument (TRANSITION-RNAV)
Standard Arrival Chart-Instrument (JEWEL)
Standard Arrival Chart-Instrument (KABOS, BAIEN, HOVER, TANSO, LUISU-RNAV)
Instrument Approach Chart (ILS Z RWY01)
Instrument Approach Chart (ILS Y or LOC Y RWY01)
Instrument Approach Chart (ILS X or LOC X RWY01)
Instrument Approach Chart (VOR RWY01)
Instrument Approach Chart (VOR A)
Instrument Approach Chart (RNP Z RWY19)
Instrument Approach Chart (RNP RWY01(AR))
Instrument Approach Chart (RNP Y RWY19(AR))
Other Chart (Visual REP)
Other Chart (MVA CHART)

RJFO / OITA

AD CHART

CHANGE : CEILO METER, WIND SPEED METER added.

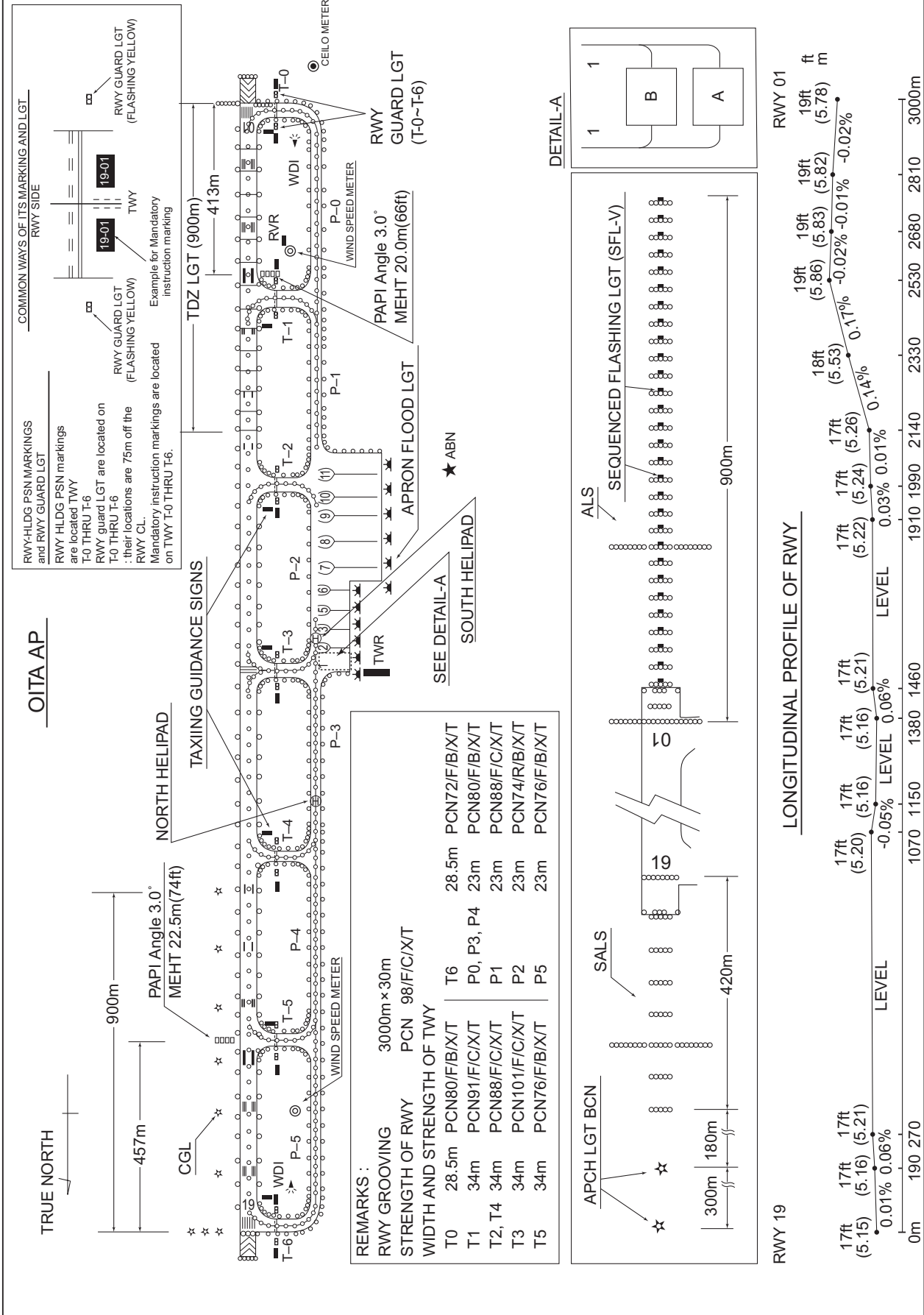

AERODROME OBSTACLE CHART-ICAO
TYPE A (OPERATING LIMITATIONS)

DIMENSIONS AND ELEVATIONS IN FEET BEARINGS ARE MAGNETIC

MAGNETIC VARIATION 7°17' W-APR 2016

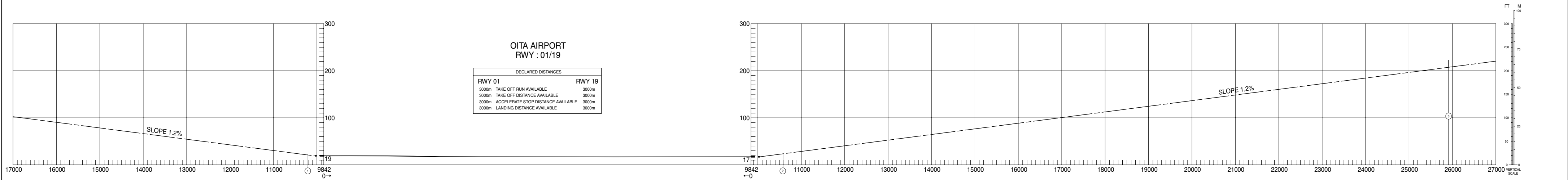

OITA AIRPORT
RWY : 01/19

DECLARED DISTANCES	
RWY 01	RWY 19
3000m TAKE OFF RUN AVAILABLE	3000m
3000m TAKE OFF DISTANCE AVAILABLE	3000m
3000m ACCELERATE STOP DISTANCE AVAILABLE	3000m
3000m LANDING DISTANCE AVAILABLE	3000m

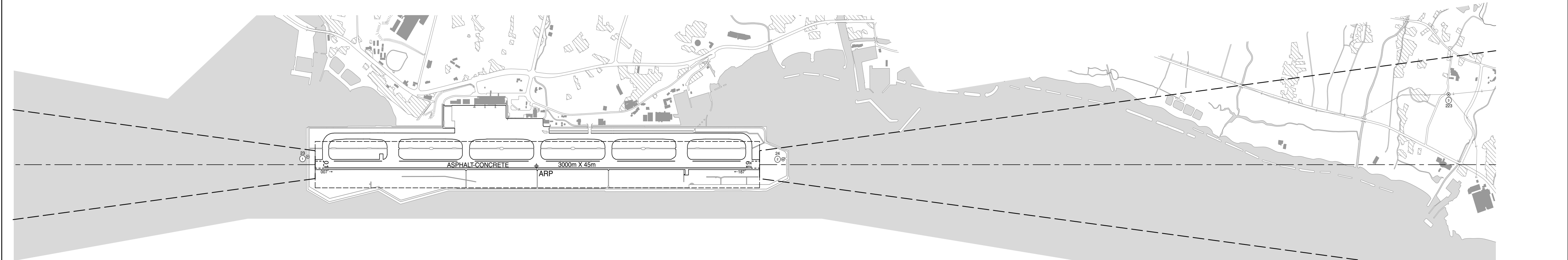

LEGEND		AMENDMENT RECORD		
		Nr	DATE	ENTERED BY
○	IDENTIFICATION NUMBER			
●	POLE, TOWER, SPIRE, ANTENNA, ETC			
✱	TREE			
—+—	RAILROAD			
—+—	TRANSMISSION LINE OR OVERHEAD CABLE			
△	TRIANGULATION POINT			
★	AERONAUTICAL GROUND LIGHT			

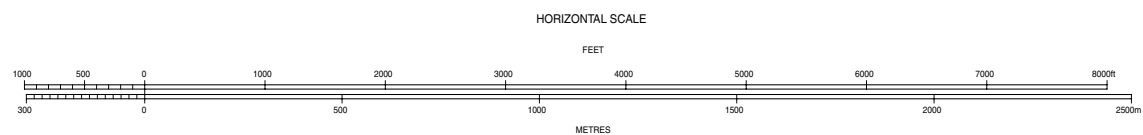

DIMENSIONS AND ELEVATIONS IN FEET BEARINGS ARE MAGNETIC
Transverse Mercator Projection

AERODROME OBSTACLE CHART-ICAO
TYPE B

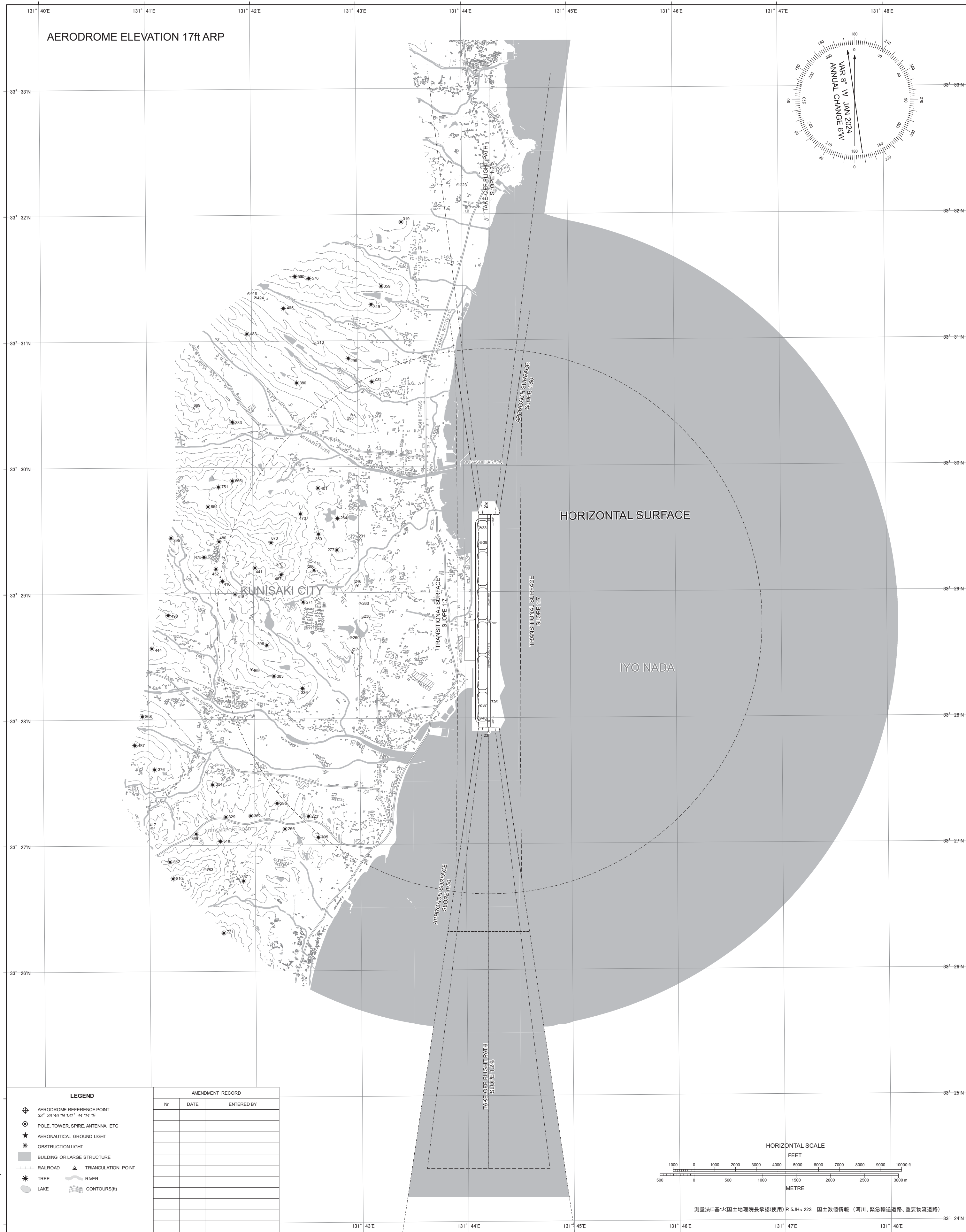

AERODROME ELEVATION 17ft ARP

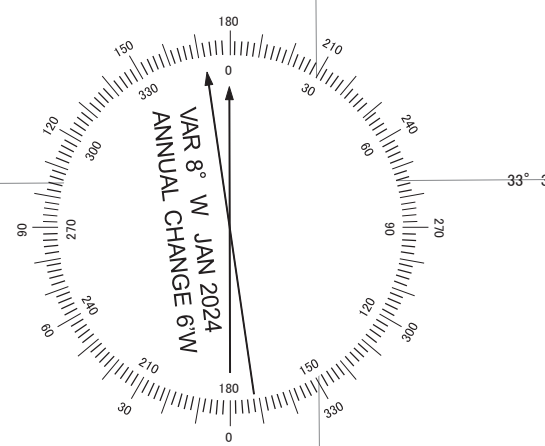

HORIZONTAL SURFACE

IYO NADA

KUNISAKI CITY

APPROACH SURFACE
SLOPE 1:30

TAKE OFF FLIGHT PATH
SLOPE 1:2%

TRANSITIONAL SURFACE
SLOPE 1:17

LEGEND

- ⊕ AERODROME REFERENCE POINT
33° 28' 46" N 131° 44' 14" E
- ⊙ POLE, TOWER, SPIRE, ANTENNA, ETC
- ★ AERONAUTICAL GROUND LIGHT
- ✴ OBSTRUCTION LIGHT
- BUILDING OR LARGE STRUCTURE
- RAILROAD
- ▲ TRIANGULATION POINT
- ✳ TREE
- LAKE
- RIVER
- ⋯ CONTOURS(1)

AMENDMENT RECORD

Nr	DATE	ENTERED BY

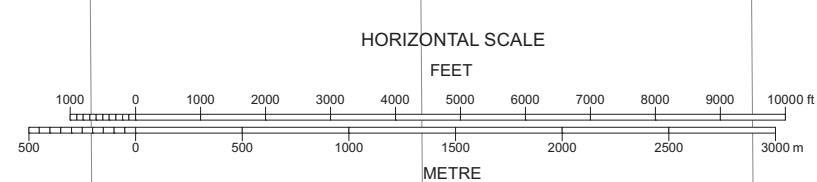

測量法に基づく国土地理院長承認(使用) R 5JHs 223 国土数値情報 (河川、緊急輸送道路、重要物流道路)

CHANGE : Update.

STANDARD DEPARTURE CHART - INSTRUMENT

RJFO / OITA

SID

MUSASHI REVERSAL TWO DEPARTURE

RWY01 : Climb RWY HDG to 500FT, turn right HDG177° to intercept and proceed via TFE R132 to TFE 10.0DME,...

RWY19 : Turn left, climb via TFE R132 to TFE 10.0DME, ...turn right, direct to TFE VOR/DME.
Cross TFE VOR/DME at or above 4000FT.

Note RWY01 : 5.0% climb gradient required up to 500FT.

OBST ALT 266FT located at 2.5NM 351° FM end of RWY01.

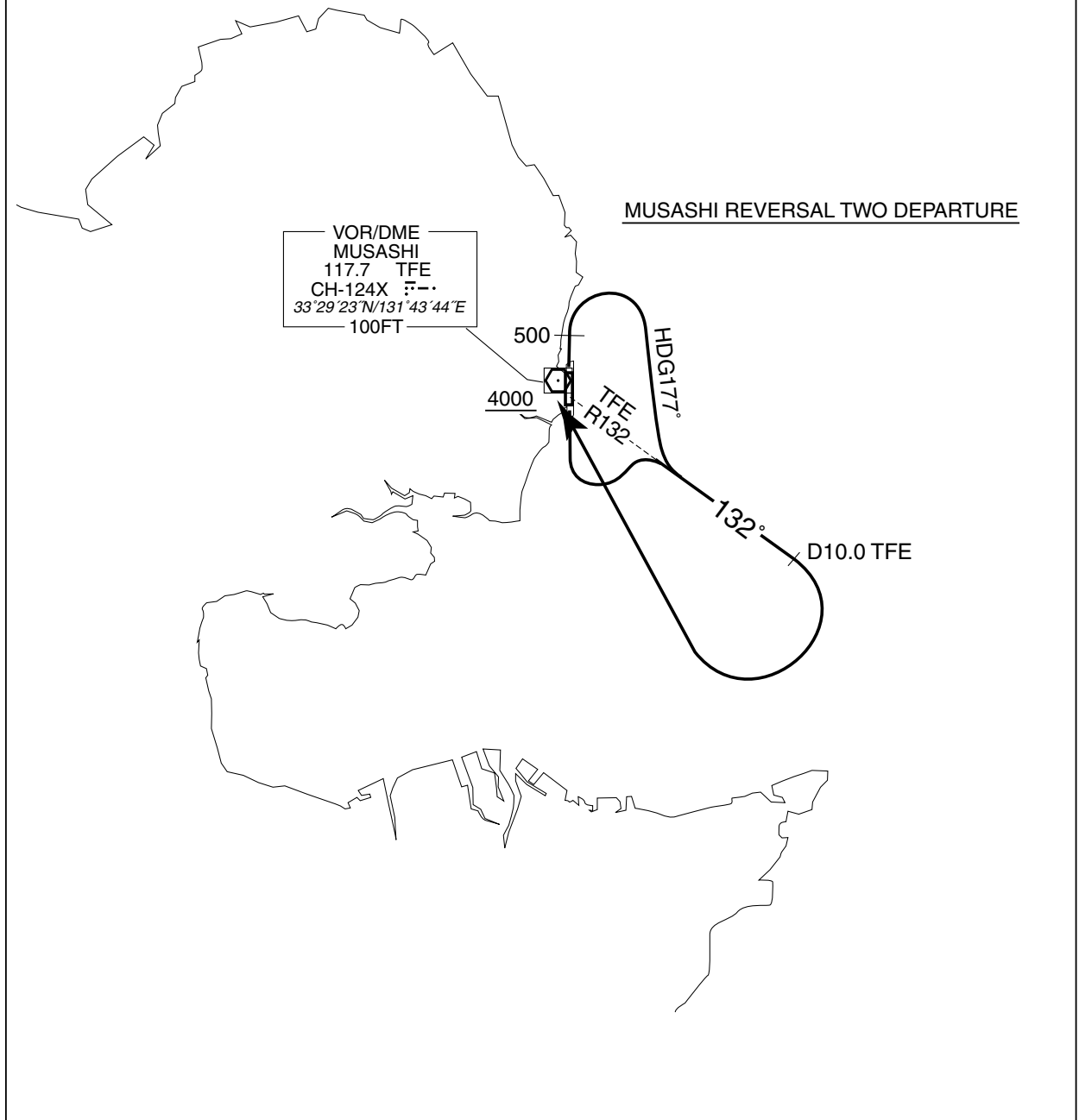

STANDARD DEPARTURE CHART - INSTRUMENT

RJFO / OITA

RNAV SID

EBOSHI TWO DEPARTURE

RNAV1

Note 1) DME/DME/IRU or GNSS required.
 ※The aircraft equipped with only DME/DME/IRU must be able to update its position without delay at the starting point of take-off roll.
 2) RADAR service required.

Critical DME

-

DME GAP

RWY01 : DER ~ 19NM to YANAI
 RWY19 : DER ~ 26NM to YANAI

Inappropriate NavAids

See AD1.1.6.10.3. Inappropriate NAVAIDs for RNAV1

VAR 7°W (2014)

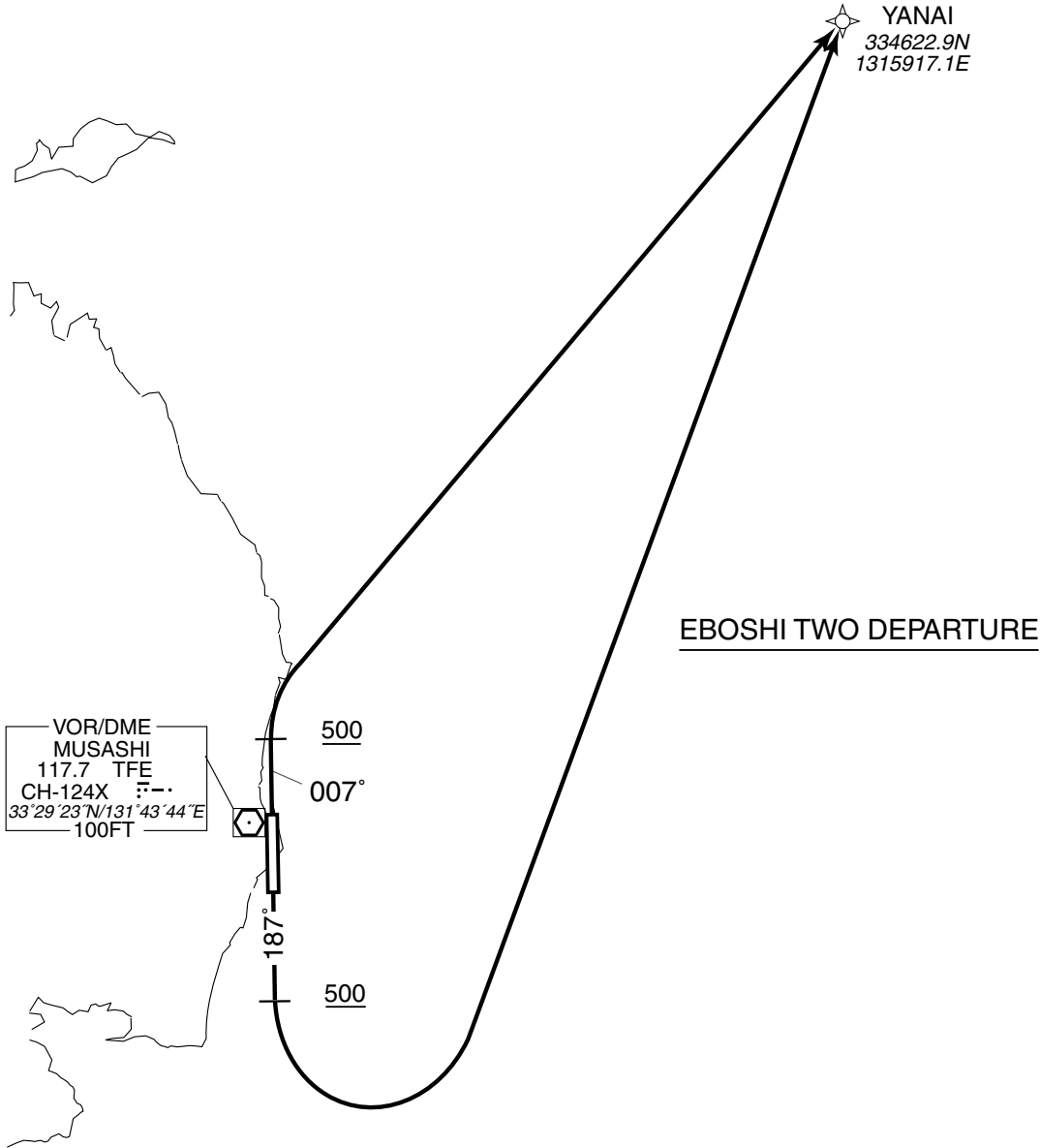

EBOSHI TWO DEPARTURE

RWY01 : Climb on HDG007° at or above 500FT, turn right direct to YANAI.

RWY19 : Climb on HDG187° at or above 500FT, turn left direct to YANAI.

Note RWY01 : 5.0% climb gradient required up to 500FT.
 OBST ALT 266FT located at 2.5NM 351° FM end of RWY01.

STANDARD DEPARTURE CHART - INSTRUMENT

RJFO / OITA

RNAV SID

EBOSHI TWO DEPARTURE

RWY01

Serial Number	Path Descriptor	Waypoint Identifier	Fly Over	Course °M(°T)	Magnetic Variation	Distance (NM)	Turn Direction	Altitude (FT)	Speed (KIAS)	Vertical Angle	Navigation Specification
001	VA	—	—	007 (000.4)	-7.0	—	—	+500	—	—	RNAV1
002	DF	YANAI	—	—	-7.0	—	R	—	—	—	RNAV1

RWY19

Serial Number	Path Descriptor	Waypoint Identifier	Fly Over	Course °M(°T)	Magnetic Variation	Distance (NM)	Turn Direction	Altitude (FT)	Speed (KIAS)	Vertical Angle	Navigation Specification
001	VA	—	—	187 (180.4)	-7.0	—	—	+500	—	—	RNAV1
002	DF	YANAI	—	—	-7.0	—	L	—	—	—	RNAV1

STANDARD DEPARTURE CHART- INSTRUMENT

RJFO / OITA

RNAV SID

TOYO THREE DEPARTURE		RNAV1
Note 1) DME/DME/IRU or GNSS required. ※The aircraft equipped with only DME/DME/IRU must be able to update its position without delay at the starting point of take-off roll. 2) RADAR service required.	Critical DME	-
	DME GAP	RWY01 : DER ~ 9NM to TACHI RWY19 : DER ~ 3NM to FO901
	Inappropriate Nav aids	See AD1.1.6.10.3. Inappropriate NAVAIDs for RNAV1

VAR 7°W (2014)

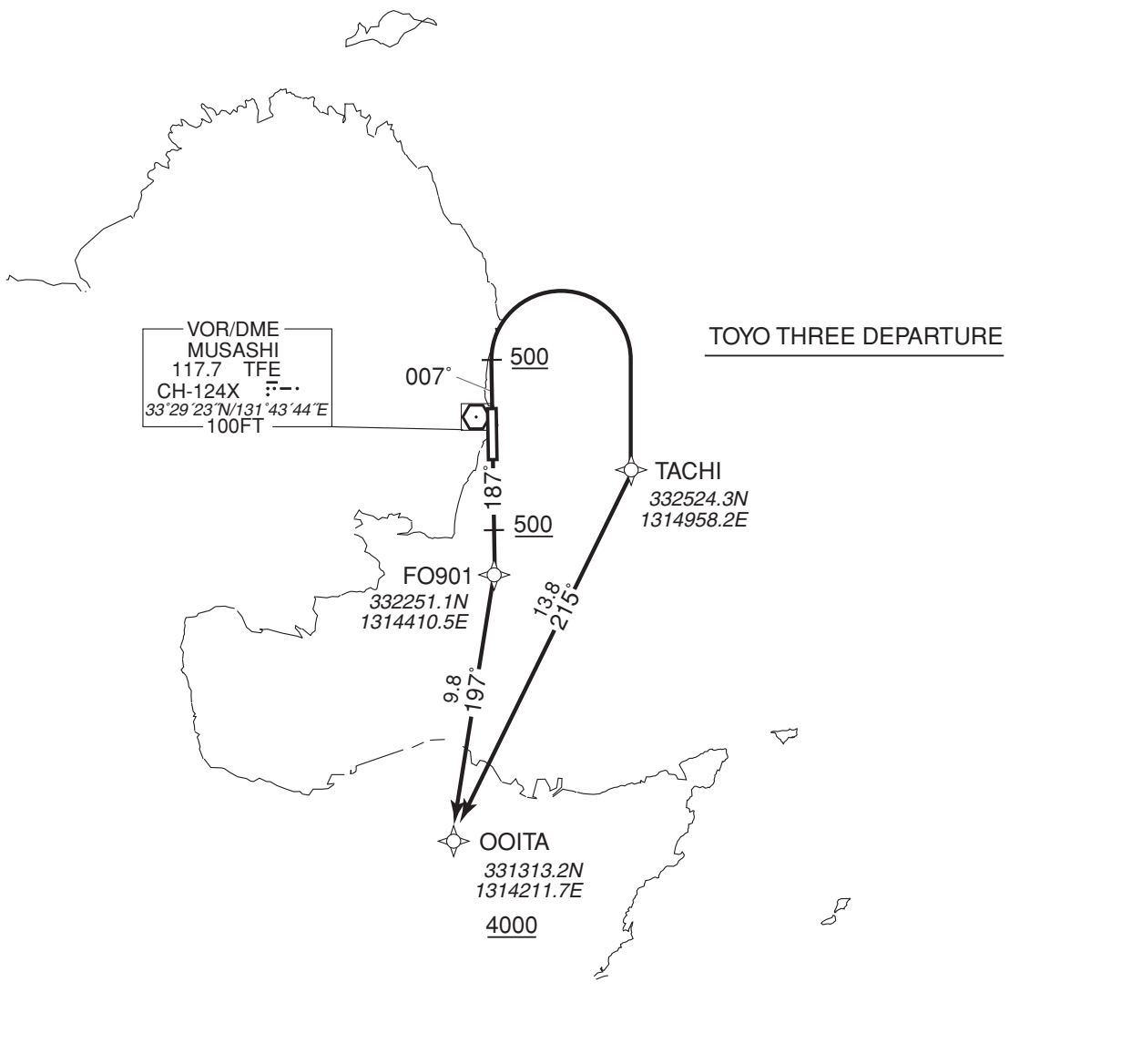

TOYO THREE DEPARTURE

RWY01 : Climb on HDG007° at or above 500FT, turn right direct to TACHI,...

RWY19 : Climb on HDG187° at or above 500FT, direct to FO901, ...
...to OOITA at or above 4000FT.

Note RWY01 : 5.0% climb gradient required up to 500FT.
OBST ALT 266FT located at 2.5NM 351° FM end of RWY01.

STANDARD DEPARTURE CHART- INSTRUMENT

RJFO / OITA

RNAV SID

TOYO THREE DEPARTURE

RWY01

Serial Number	Path Descriptor	Waypoint Identifier	Fly Over	Course °M(°T)	Magnetic Variation	Distance (NM)	Turn Direction	Altitude (FT)	Speed (KIAS)	Vertical Angle	Navigation Specification
001	VA	—	—	007 (000.4)	-7.0	—	—	+500	—	—	RNAV1
002	DF	TACHI	—	—	-7.0	—	R	—	—	—	RNAV1
003	TF	OOITA	—	215 (208.1)	-7.0	13.8	—	+4000	—	—	RNAV1

RWY19

Serial Number	Path Descriptor	Waypoint Identifier	Fly Over	Course °M(°T)	Magnetic Variation	Distance (NM)	Turn Direction	Altitude (FT)	Speed (KIAS)	Vertical Angle	Navigation Specification
001	VA	—	—	187 (180.4)	-7.0	—	—	+500	—	—	RNAV1
002	DF	FO901	—	—	-7.0	—	—	—	—	—	RNAV1
003	TF	OOITA	—	197 (189.8)	-7.0	9.8	—	+4000	—	—	RNAV1

STANDARD DEPARTURE CHART - INSTRUMENT

RJFO / OITA

RNAV SID

FUSHA ONE DEPARTURE		RNAV1
Note 1) DME/DME/IRU or GNSS required. ※The aircraft equipped with only DME/DME/IRU must be able to update its position without delay at the starting point of take-off roll. 2) RADAR service required.	Critical DME	RWY01 : MYE 25NM to FUSHA ~ 24NM to FUSHA
	DME GAP	RWY01 : DER ~ 25NM to FUSHA RWY19 : DER ~ 23NM to FUSHA
	Inappropriate Nav aids	See AD1.1.6.10.3. Inappropriate NAV AIDs for RNAV1

VAR 7°W (2014)

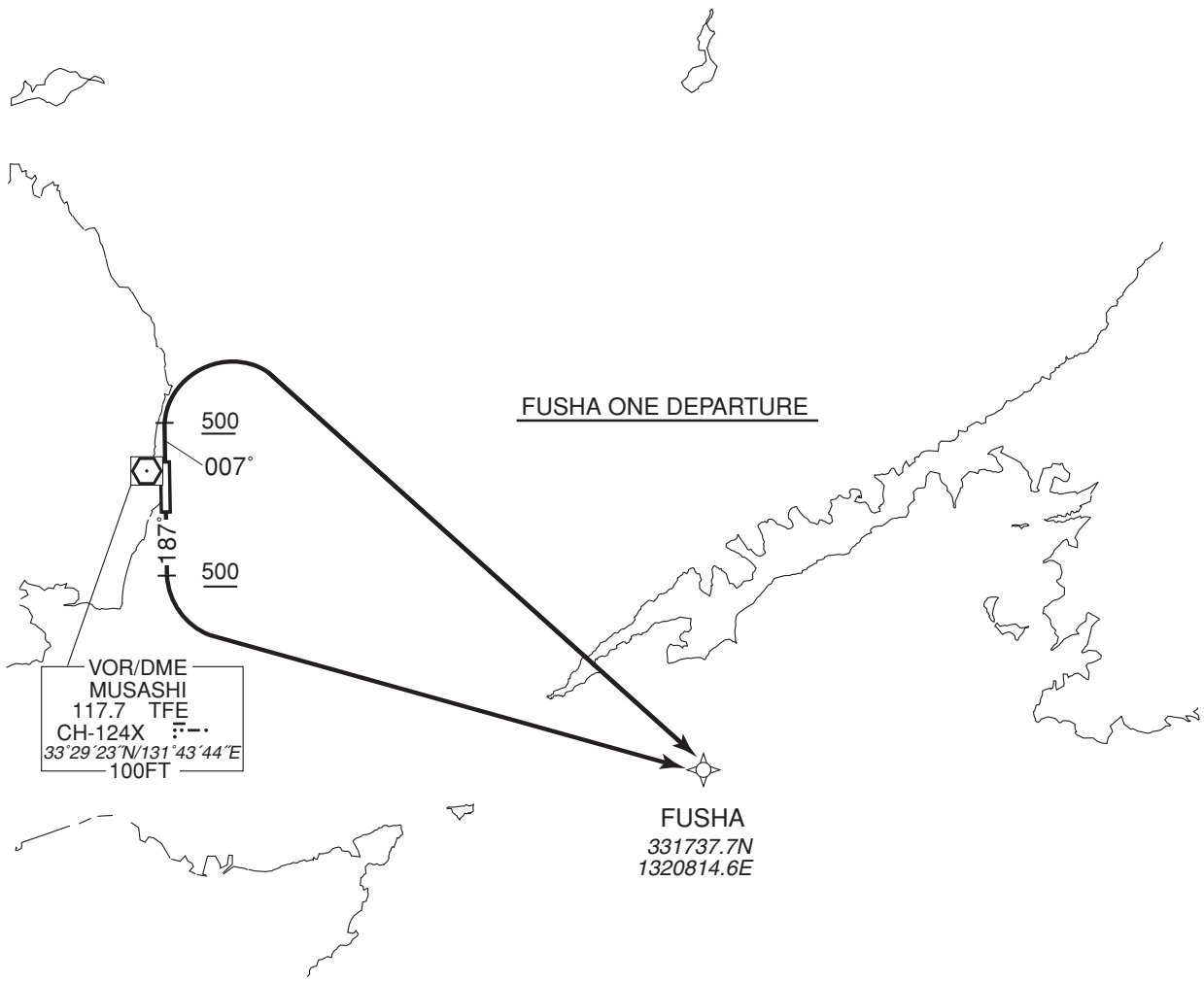

FUSHA ONE DEPARTURE

RWY01 : Climb on HDG007° at or above 500FT, turn right direct to FUSHA.

RWY19 : Climb on HDG187° at or above 500FT, turn left direct to FUSHA.

Note RWY01 : 5.0% climb gradient required up to 500FT.
OBST ALT 266FT located at 2.5NM 351° FM end of RWY01.

STANDARD DEPARTURE CHART - INSTRUMENT

RJFO / OITA

RNAV SID

FUSHA ONE DEPARTURE

RWY01

Serial Number	Path Descriptor	Waypoint Identifier	Fly Over	Course °M(°T)	Magnetic Variation	Distance (NM)	Turn Direction	Altitude (FT)	Speed (KIAS)	Vertical Angle	Navigation Specification
001	VA	—	—	007 (000.4)	-7.0	—	—	+500	—	—	RNAV1
002	DF	FUSHA	—	—	-7.0	—	R	—	—	—	RNAV1

RWY19

Serial Number	Path Descriptor	Waypoint Identifier	Fly Over	Course °M(°T)	Magnetic Variation	Distance (NM)	Turn Direction	Altitude (FT)	Speed (KIAS)	Vertical Angle	Navigation Specification
001	VA	—	—	187 (180.4)	-7.0	—	—	+500	—	—	RNAV1
002	DF	FUSHA	—	—	-7.0	—	L	—	—	—	RNAV1

STANDARD DEPARTURE CHART - INSTRUMENT

RJFO / OITA

RNAV TRANSITION

DONAR TRANSITION / DOUGO TRANSITION / FIATO TRANSITION SALTY TRANSITION / SPIDE TRANSITION / ASHIZURI TRANSITION		RNAV1
Note 1) DME/DME/IRU or GNSS required. 2) RADAR service required.	Critical DME	-
	DME GAP	-
	Inappropriate Nav aids	See AD1.1.6.10.3. Inappropriate NAVAIDs for RNAV1

VAR 7°W (2017)

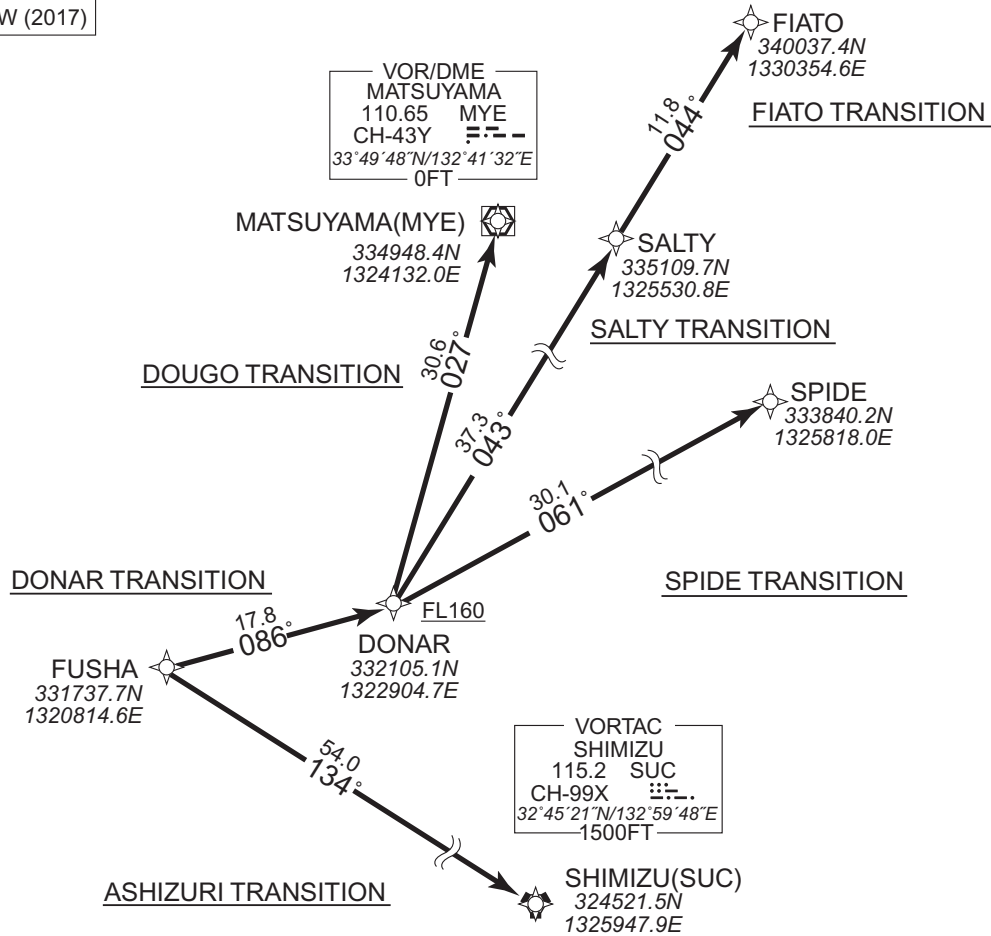

<u>DONAR TRANSITION</u> From FUSHA, to DONAR at or above FL160.
<u>DOUGO TRANSITION</u> From FUSHA, to DONAR at or above FL160, to MYE.
<u>FIATO TRANSITION</u> From FUSHA, to DONAR at or above FL160, to SALTY, to FIATO.
<u>SALTY TRANSITION</u> From FUSHA, to DONAR at or above FL160, to SALTY.
<u>SPIDE TRANSITION</u> From FUSHA, to DONAR at or above FL160, to SPIDE.
<u>ASHIZURI TRANSITION</u> From FUSHA, to SUC.

CHANGE : Critical DME deleted.

STANDARD DEPARTURE CHART - INSTRUMENT

RJFO / OITA

RNAV TRANSITION

DONAR TRANSITION

Serial Number	Path Descriptor	Waypoint Identifier	Fly Over	Course °M(°T)	Magnetic Variation	Distance (NM)	Turn Direction	Altitude (FT)	Speed (KIAS)	Vertical Angle	Navigation Specification
001	IF	FUSHA	—	—	-7.4	—	—	—	—	—	RNAV1
002	TF	DONAR	—	086 (078.7)	-7.4	17.8	—	+FL160	—	—	RNAV1

DOUGO TRANSITION

Serial Number	Path Descriptor	Waypoint Identifier	Fly Over	Course °M(°T)	Magnetic Variation	Distance (NM)	Turn Direction	Altitude (FT)	Speed (KIAS)	Vertical Angle	Navigation Specification
001	IF	FUSHA	—	—	-7.4	—	—	—	—	—	RNAV1
002	TF	DONAR	—	086 (078.7)	-7.4	17.8	—	+FL160	—	—	RNAV1
003	TF	MYE	—	027 (019.8)	-7.4	30.6	—	—	—	—	RNAV1

FIATO TRANSITION

Serial Number	Path Descriptor	Waypoint Identifier	Fly Over	Course °M(°T)	Magnetic Variation	Distance (NM)	Turn Direction	Altitude (FT)	Speed (KIAS)	Vertical Angle	Navigation Specification
001	IF	FUSHA	—	—	-7.4	—	—	—	—	—	RNAV1
002	TF	DONAR	—	086 (078.7)	-7.4	17.8	—	+FL160	—	—	RNAV1
003	TF	SALTY	—	043 (036.1)	-7.4	37.3	—	—	—	—	RNAV1
004	TF	FIATO	—	044 (036.3)	-7.4	11.8	—	—	—	—	RNAV1

SALTY TRANSITION

Serial Number	Path Descriptor	Waypoint Identifier	Fly Over	Course °M(°T)	Magnetic Variation	Distance (NM)	Turn Direction	Altitude (FT)	Speed (KIAS)	Vertical Angle	Navigation Specification
001	IF	FUSHA	—	—	-7.4	—	—	—	—	—	RNAV1
002	TF	DONAR	—	086 (078.7)	-7.4	17.8	—	+FL160	—	—	RNAV1
003	TF	SALTY	—	043 (036.1)	-7.4	37.3	—	—	—	—	RNAV1

STANDARD DEPARTURE CHART - INSTRUMENT

RJFO / OITA

RNAV TRANSITION

SPIDE TRANSITION

Serial Number	Path Descriptor	Waypoint Identifier	Fly Over	Course °M(°T)	Magnetic Variation	Distance (NM)	Turn Direction	Altitude (FT)	Speed (KIAS)	Vertical Angle	Navigation Specification
001	IF	FUSHA	—	—	-7.4	—	—	—	—	—	RNAV1
002	TF	DONAR	—	086 (078.7)	-7.4	17.8	—	+FL160	—	—	RNAV1
003	TF	SPIDE	—	061 (054.1)	-7.4	30.1	—	—	—	—	RNAV1

ASHIZURI TRANSITION

Serial Number	Path Descriptor	Waypoint Identifier	Fly Over	Course °M(°T)	Magnetic Variation	Distance (NM)	Turn Direction	Altitude (FT)	Speed (KIAS)	Vertical Angle	Navigation Specification
001	IF	FUSHA	—	—	-7.4	—	—	—	—	—	RNAV1
002	TF	SUC	—	134 (126.5)	-7.4	54.0	—	—	—	—	RNAV1

STANDARD ARRIVAL CHART- INSTRUMENT

RJFO / OITA

STAR

JEWEL ARRIVAL

From over DONKO, via TFE R038 to JEWEL.

Cross DONKO at or above 5000FT, cross JEWEL at or above 3000FT.

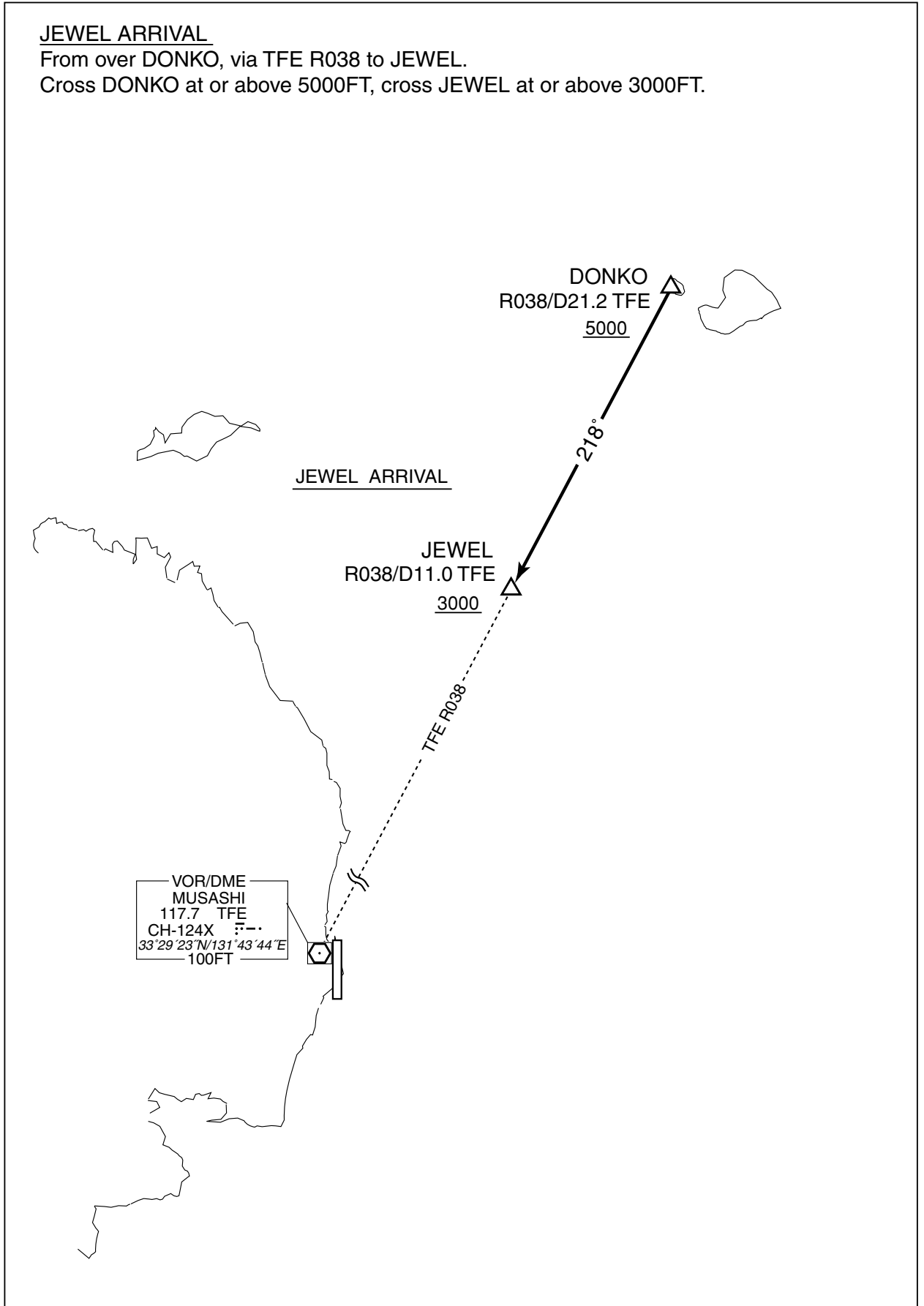

STANDARD ARRIVAL CHART- INSTRUMENT

RJFO / OITA

RNAV STAR

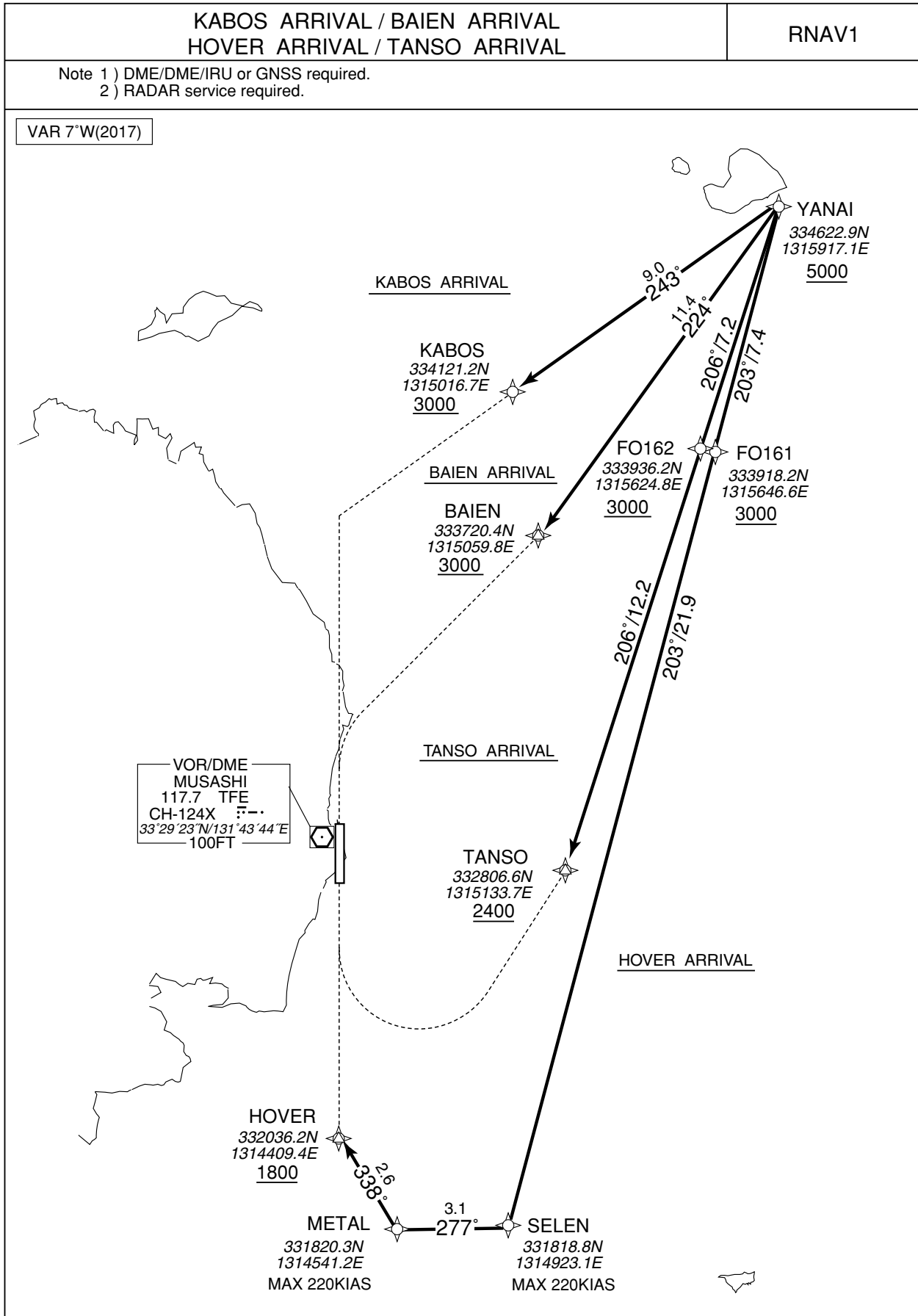

STANDARD ARRIVAL CHART - INSTRUMENT

RJFO / OITA

RNAV STAR

KABOS ARRIVAL

From YANAI at or above 5000FT, to KABOS at or above 3000FT.

Critical DME	-
DME GAP	-
Inappropriate Navaids	See AD1.1.6.10.3. Inappropriate NAVAIDs for RNAV1

Serial Number	Path Descriptor	Waypoint Identifier	Fly Over	Course °M(°T)	Magnetic Variation	Distance (NM)	Turn Direction	Altitude (FT)	Speed (KIAS)	Vertical Angle	Navigation Specification
001	IF	YANAI	-	-	-7.4	-	-	+5000	-	-	RNAV1
002	TF	KABOS	-	243 (236.2)	-7.4	9.0	-	+3000	-	-	RNAV1

HOVER ARRIVAL

From YANAI at or above 5000FT, to FO161 at or above 3000FT, to SELEN, to METAL, to HOVER at or above 1800FT.

Critical DME	-
DME GAP	-
Inappropriate Navaids	See AD1.1.6.10.3. Inappropriate NAVAIDs for RNAV1

Serial Number	Path Descriptor	Waypoint Identifier	Fly Over	Course °M(°T)	Magnetic Variation	Distance (NM)	Turn Direction	Altitude (FT)	Speed (KIAS)	Vertical Angle	Navigation Specification
001	IF	YANAI	-	-	-7.4	-	-	+5000	-	-	RNAV1
002	TF	FO161	-	203 (196.4)	-7.4	7.4	-	+3000	-	-	RNAV1
003	TF	SELEN	-	203 (196.4)	-7.4	21.9	-	-	-220	-	RNAV1
004	TF	METAL	-	277 (270.5)	-7.4	3.1	-	-	-220	-	RNAV1
005	TF	HOVER	-	338 (330.5)	-7.4	2.6	-	+1800	-	-	RNAV1

STANDARD ARRIVAL CHART - INSTRUMENT

RJFO / OITA

RNAV STAR

BAIEN ARRIVAL

From YANAI at or above 5000FT, to BAIEN at or above 3000FT.

Critical DME	–
DME GAP	–
Inappropriate Nav aids	See AD1.1.6.10.3. Inappropriate NAVAIDs for RNAV1

Serial Number	Path Descriptor	Waypoint Identifier	Fly Over	Course °M(°T)	Magnetic Variation	Distance (NM)	Turn Direction	Altitude (FT)	Speed (KIAS)	Vertical Angle	Navigation Specification
001	IF	YANAI	–	–	-7.4	–	–	+5000	–	–	RNAV1
002	TF	BAIEN	–	224 (217.4)	-7.4	11.4	–	+3000	–	–	RNAV1

TANSO ARRIVAL

From YANAI at or above 5000FT, to FO162 at or above 3000FT, to TANSO at or above 2400FT.

Critical DME	–
DME GAP	–
Inappropriate Nav aids	See AD1.1.6.10.3. Inappropriate NAVAIDs for RNAV1

Serial Number	Path Descriptor	Waypoint Identifier	Fly Over	Course °M(°T)	Magnetic Variation	Distance (NM)	Turn Direction	Altitude (FT)	Speed (KIAS)	Vertical Angle	Navigation Specification
001	IF	YANAI	–	–	-7.4	–	–	+5000	–	–	RNAV1
002	TF	FO162	–	206 (199.4)	-7.4	7.2	–	+3000	–	–	RNAV1
003	TF	TANSO	–	206 (199.4)	-7.4	12.2	–	+2400	–	–	RNAV1

STANDARD ARRIVAL CHART - INSTRUMENT

RJFO / OITA

RNAV STAR

<p>LUISU ARRIVAL</p>	<p>RNAV1</p>
-----------------------------	---------------------

Note 1) DME/DME/IRU or GNSS required.
2) RADAR service required.

VAR 7°W(2016)

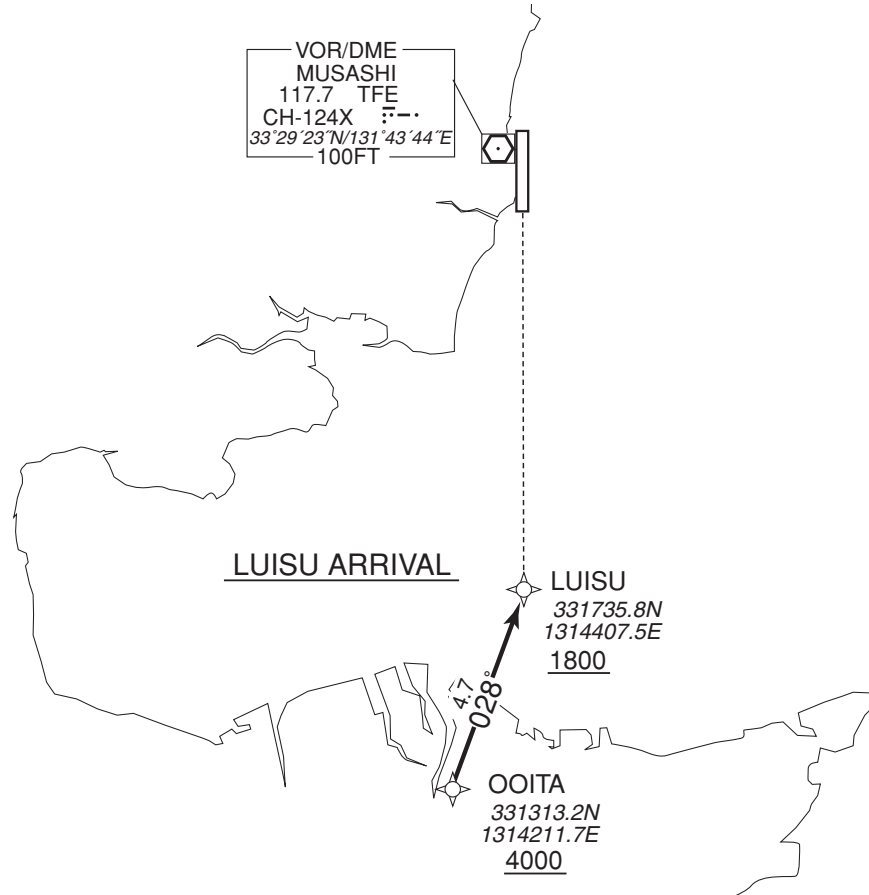

LUISU ARRIVAL

From OOITA at or above 4000FT, to LUISU at or above 1800FT.

Critical DME	-
DME GAP	-
Inappropriate Navaids	See AD1.1.6.10.3. Inappropriate NAVAIDs for RNAV1

Serial Number	Path Descriptor	Waypoint Identifier	Fly Over	Course °M(°T)	Magnetic Variation	Distance (NM)	Turn Direction	Altitude (FT)	Speed (KIAS)	Vertical Angle	Navigation Specification
001	IF	OOITA	-	-	-7.3	-	-	+4000	-	-	RNAV1
002	TF	LUISU	-	028 (020.2)	-7.3	4.7	-	+1800	-	-	RNAV1

INSTRUMENT APPROACH CHART

RJFO / OITA

ILS Z RWY01

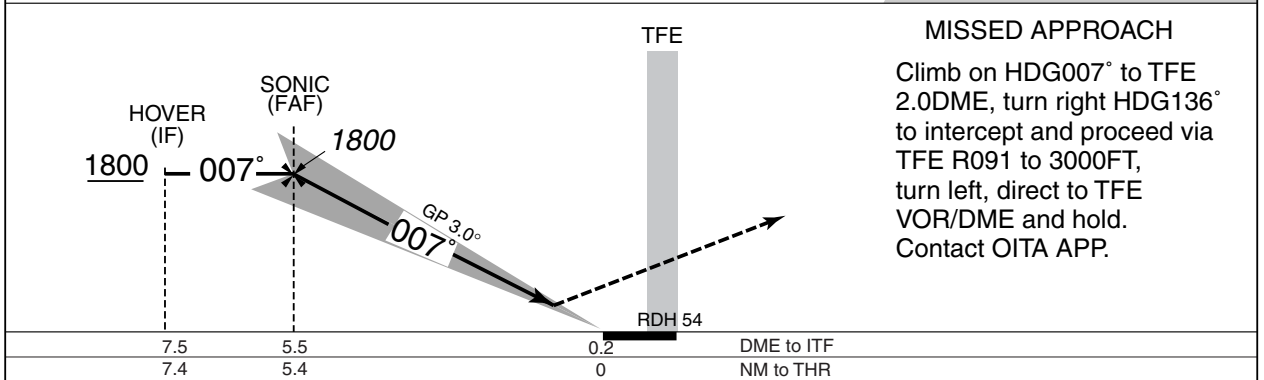
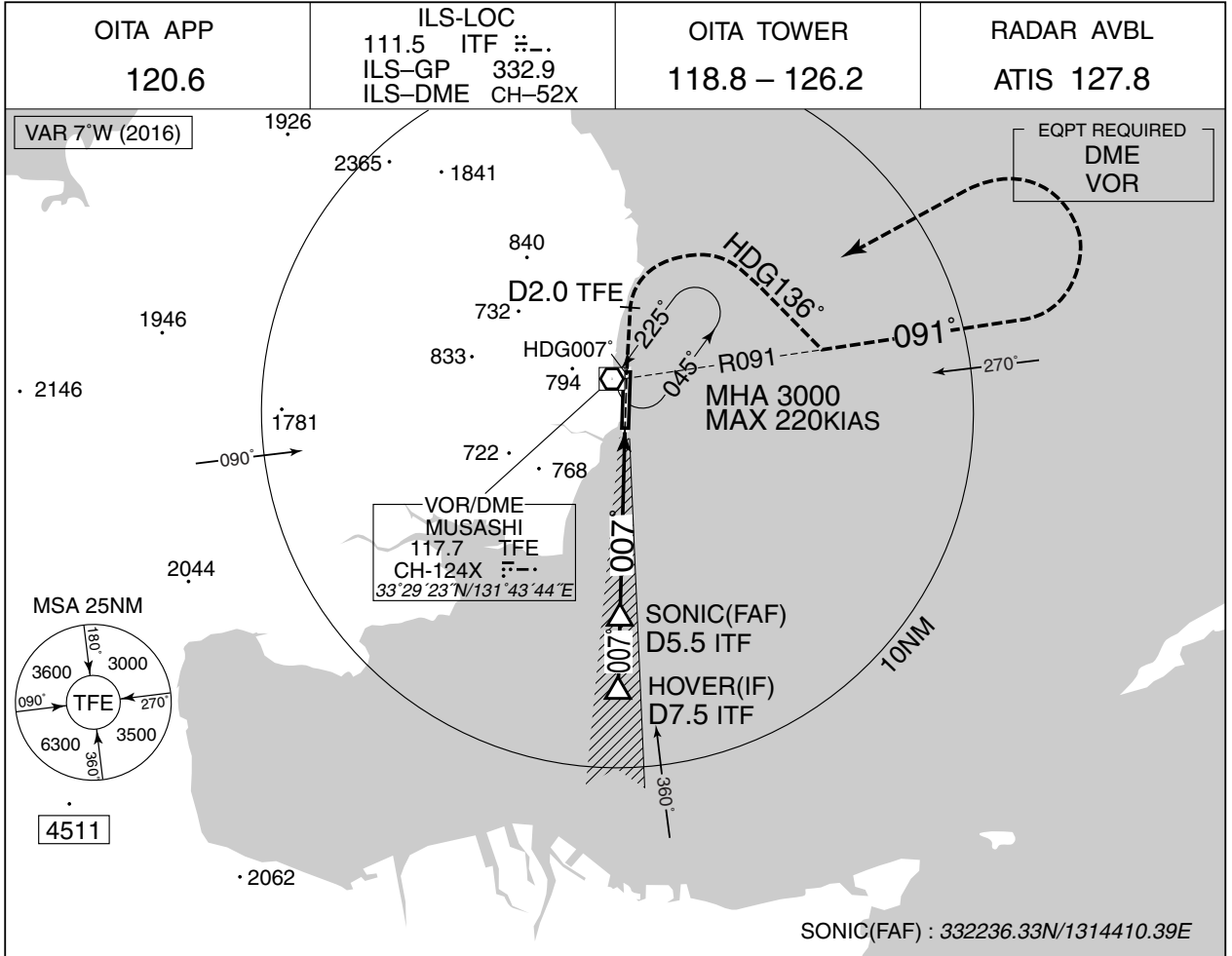

Missed APCH climb gradient MNM 4.0%.

MINIMA	THR elev. 19	AD elev. 17		
CAT	CAT I		CIRCLING	
	DA(H)	RVR/CMV	MDA(H)	VIS
A	219 (200)	550	430 (413)	1600
B			470 (453)	
C			690 (673)	2400
D			760 (743)	3200

MINIMA with Missed APCH climb gradient of 2.5% are not established.
Circling to EAST side of RWY only.

INSTRUMENT APPROACH CHART

RJFO / OITA

ILS Y or LOC Y RWY01

OITA APP 120.6	ILS-LOC 111.5 ITF #-- ILS-GP 332.9 ILS-DME CH-52X	OITA TOWER 118.8 - 126.2	RADAR AVBL ATIS 127.8
-------------------	--	-----------------------------	--------------------------

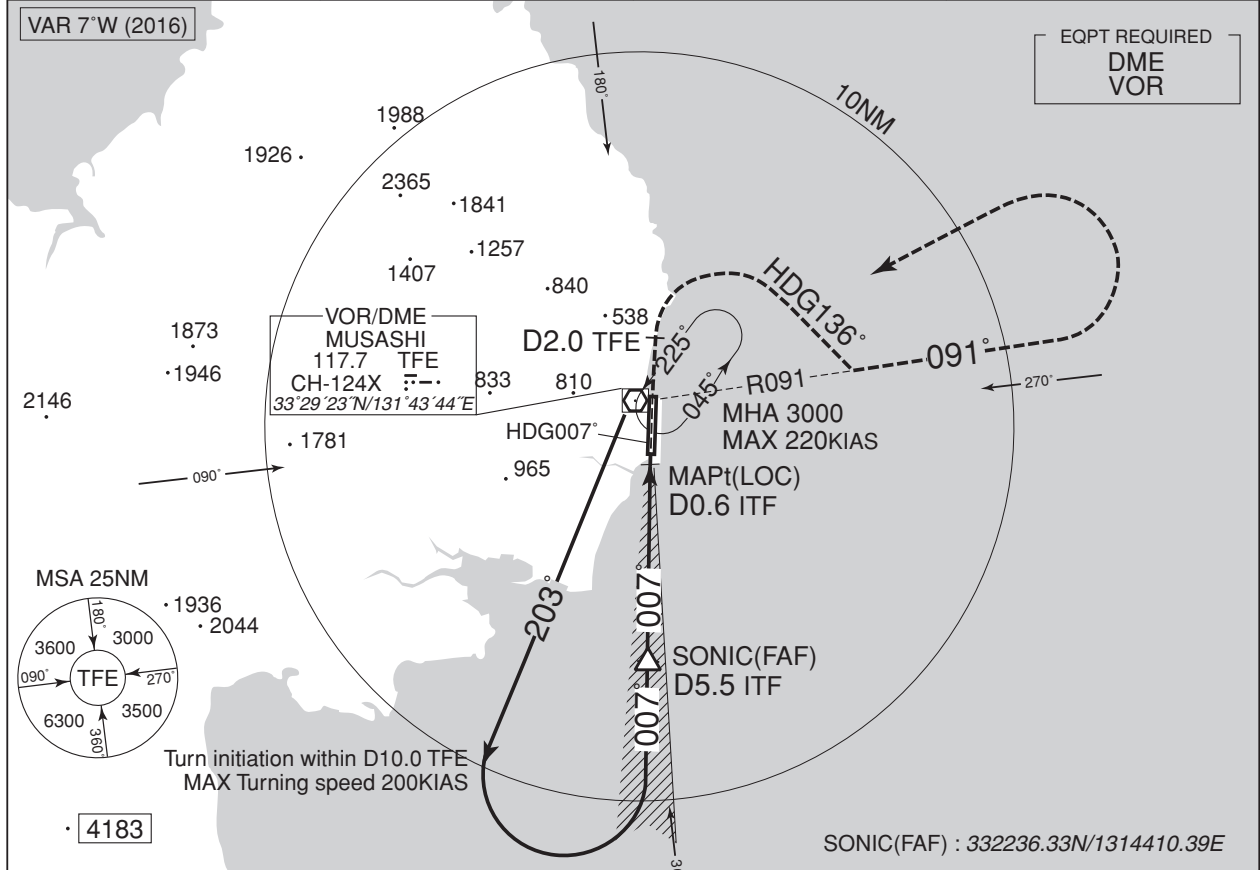

NM to ITF	FAF	5	4	3	2	1	MAPt
ALT (3.0° APCH Path)	1770	1604	1286	968	649	330	-

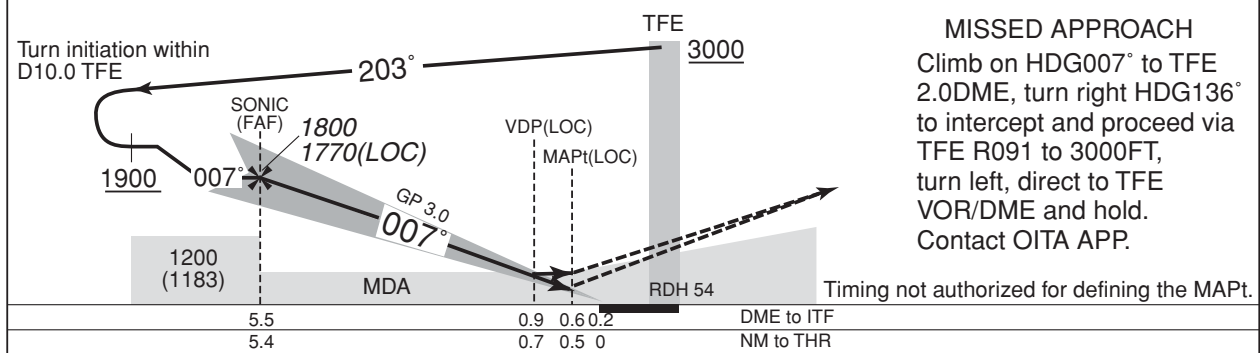

Missed APCH climb gradient MNM 4.0%.

MINIMA		THR elev. 19		AD elev. 17		
CAT	CAT I		LOC		CIRCLING	
	DA(H)	RVR/CMV	MDA(H)	RVR/CMV	MDA(H)	VIS
A	219 (200)	550	300 (283)	800	430 (413)	1600
B					470 (453)	
C					690 (673)	
D					760 (743)	

MINIMA with Missed APCH climb gradient of 2.5% are not established.
Circling to EAST side of RWY only.

CHANGE : MDA(H), VDP

INSTRUMENT APPROACH CHART

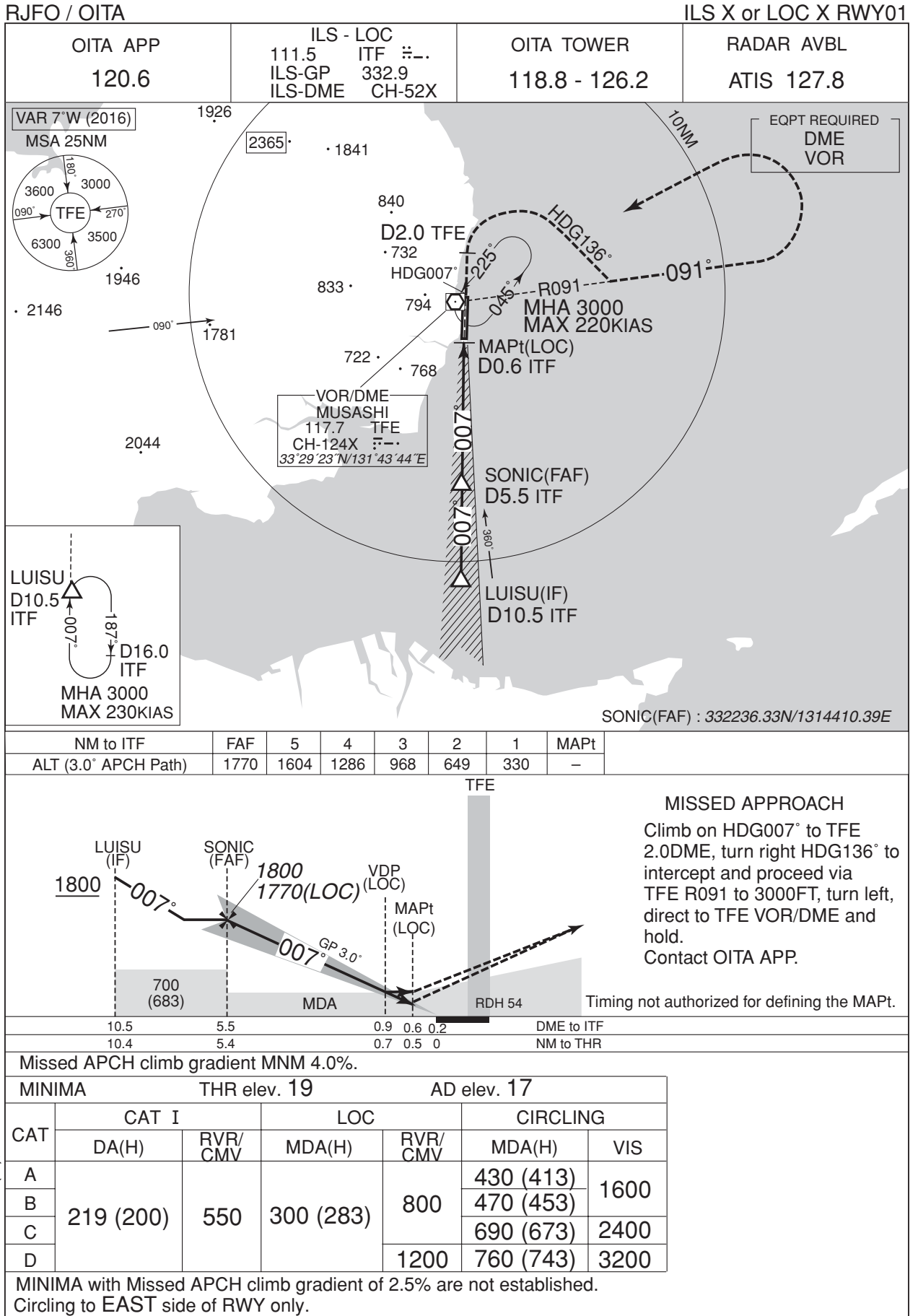

INSTRUMENT APPROACH CHART

RJFO / OITA

VOR RWY01

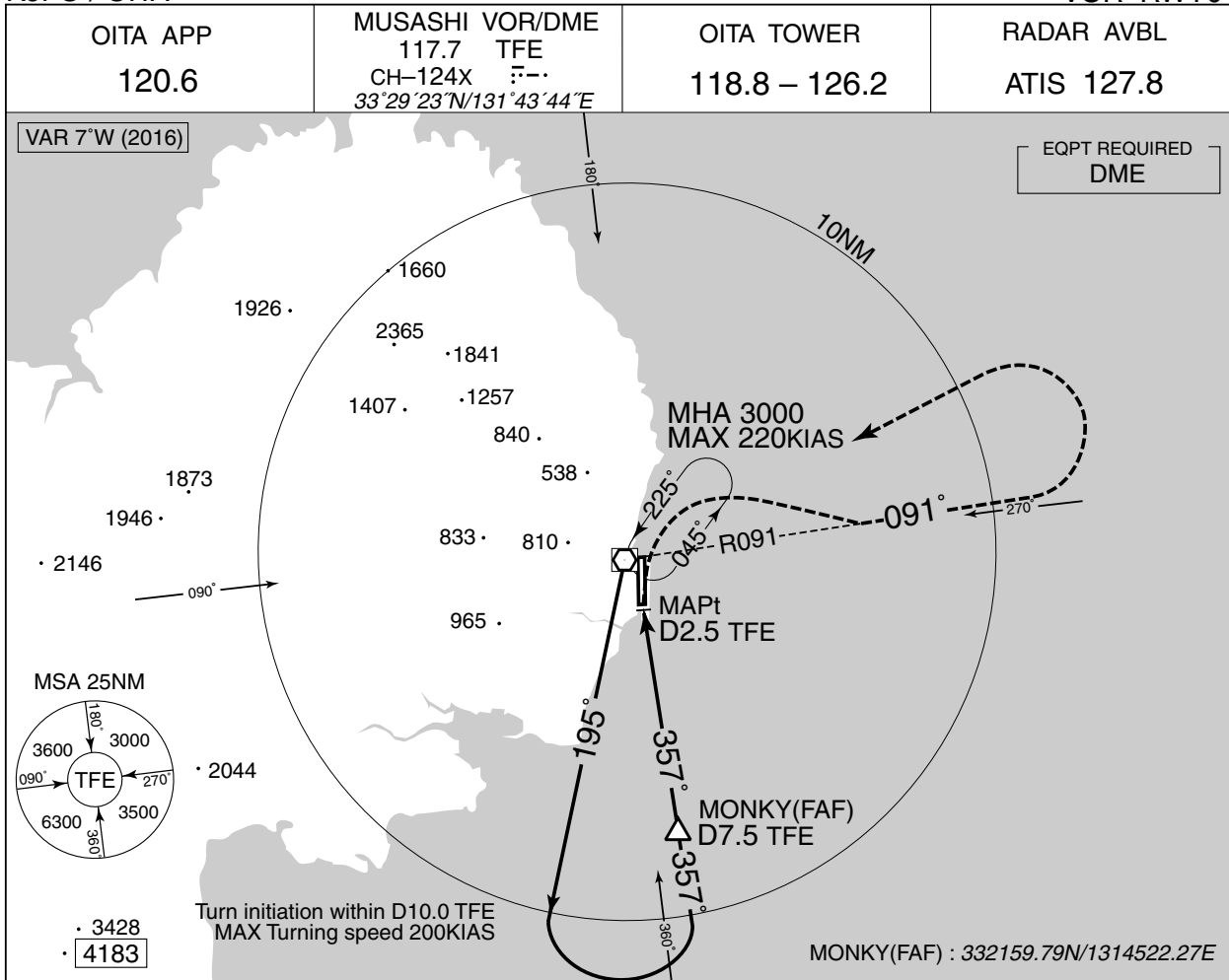

NM to TFE	FAF	7	6	5	4	3	MAPt
ALT (3.0° APCH Path)	1986	1825	1507	1189	871	552	-

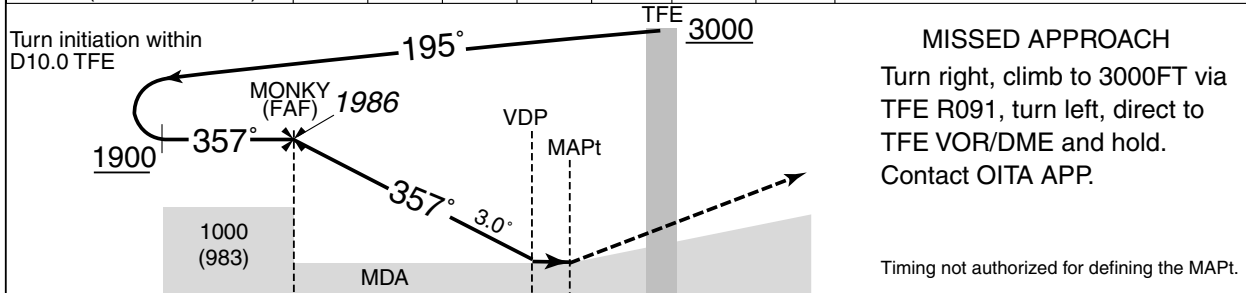

7.5	6.0	2.9	2.5	1.5	DME to TFE
		1.4	1.0	0	NM to THR

MINIMA		THR elev. 19	AD elev. 17	
CAT			CIRCLING	
	MDA(H)	RVR/CMV	MDA(H)	VIS
A	500 (483)	1000	500 (483)	1600
B		1200		
C		690 (673)	2400	
D		1600	760 (743)	3200
Circling to EAST side of RWY only.				

INSTRUMENT APPROACH CHART

RJFO / OITA VOR A

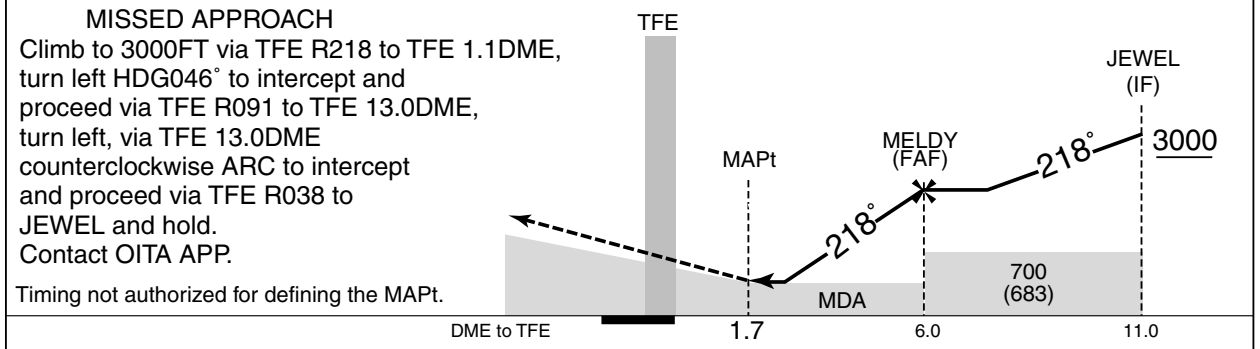
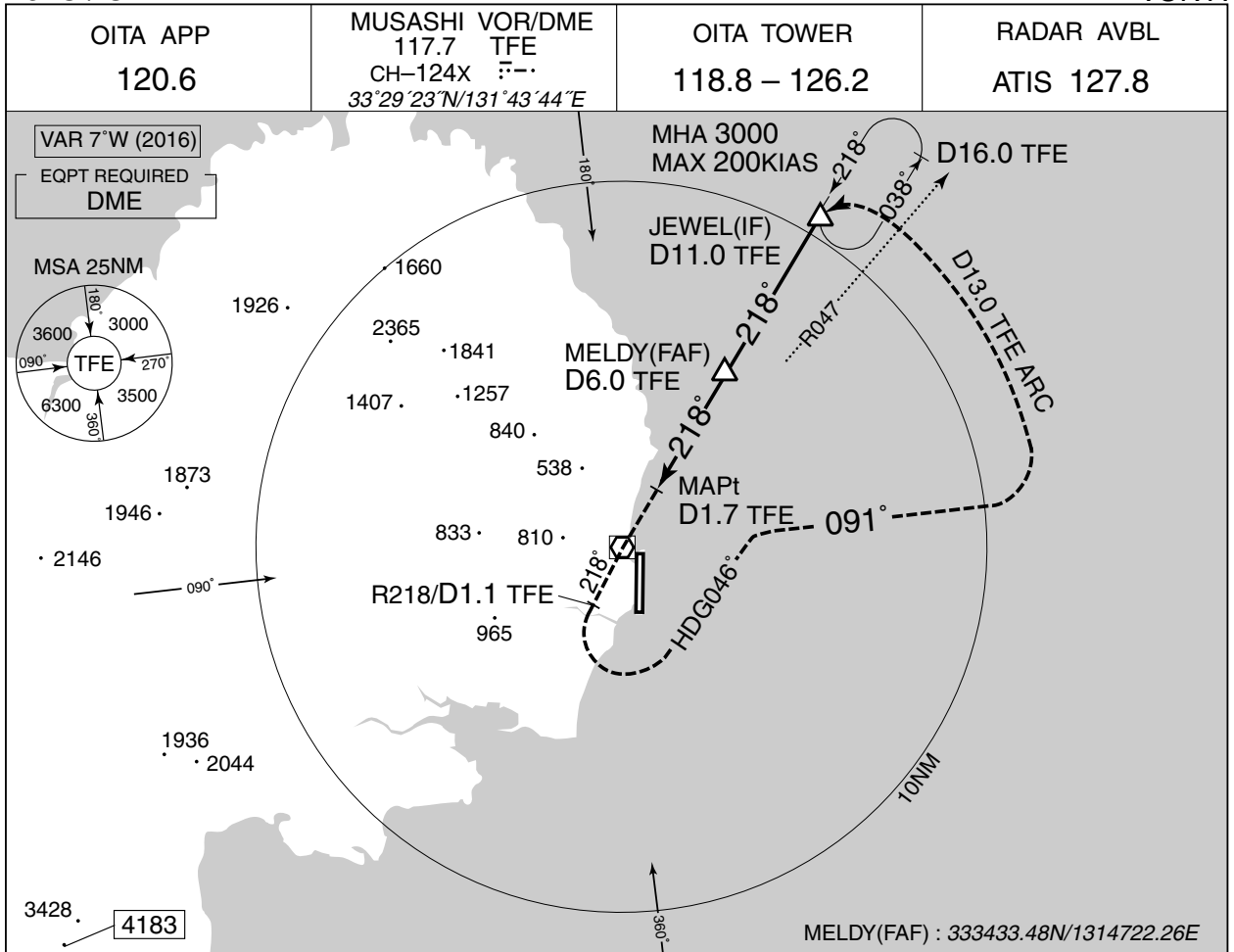

Missed APCH climb gradient MNM 5.0%.

MINIMA		AD elev. 17
CAT	CIRCLING	
	MDA(H)	VIS
A	440 (423)	1600
B	480 (463)	
C	660 (643)	2400
D	760 (743)	3200

MINIMA with Missed APCH climb gradient of 2.5% are not established.
 Circling to EAST side of RWY only.

INSTRUMENT APPROACH CHART

RJFO / OITA

RNP Z RWY19

OITA APP 120.6	RNP APCH	OITA TOWER 118.8 – 126.2	RADAR AVBL ATIS 127.8
-------------------	----------	-----------------------------	--------------------------

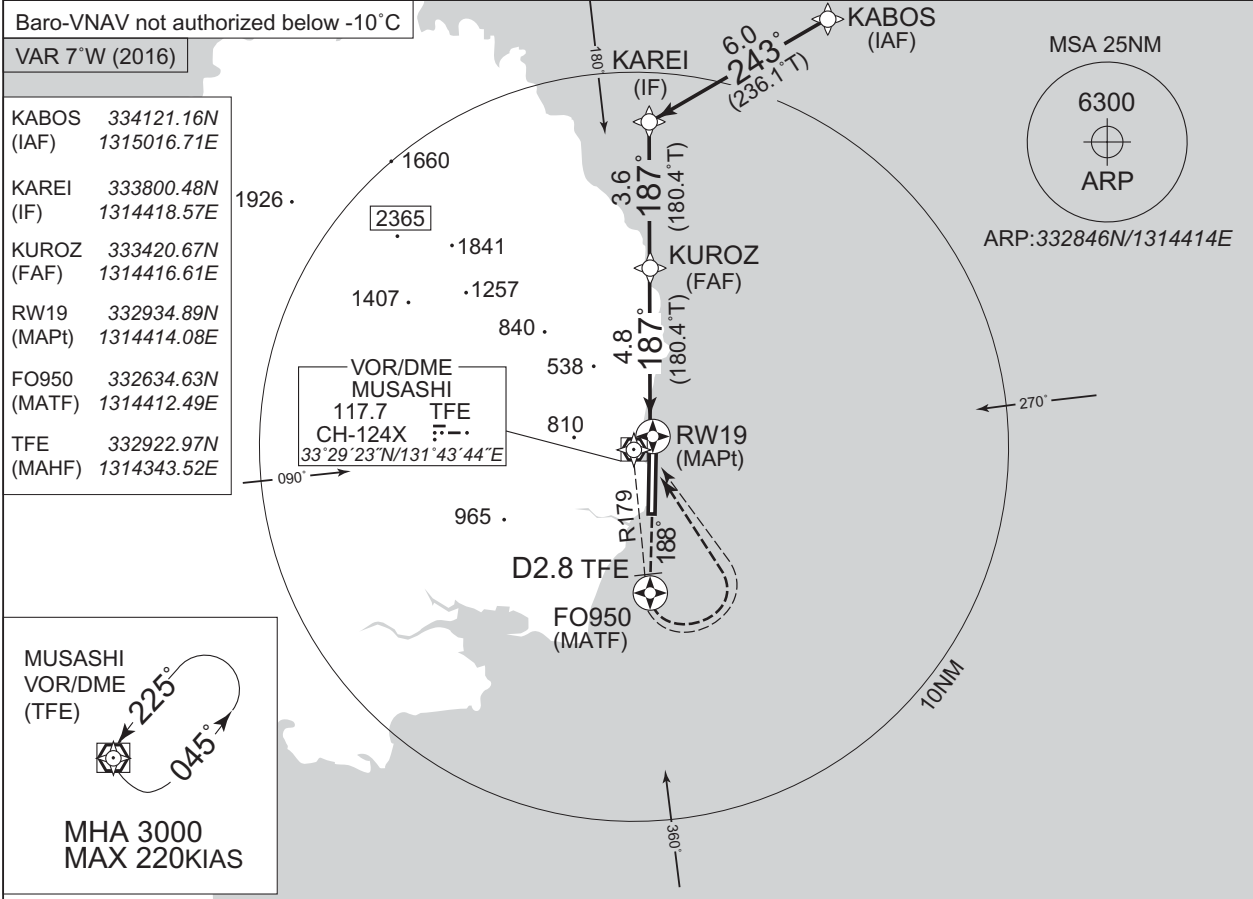

NM to Next Fix	MAPt	2	3	4	FAF
ALT (3.0° APCH Path)	-	703	1021	1340	1600

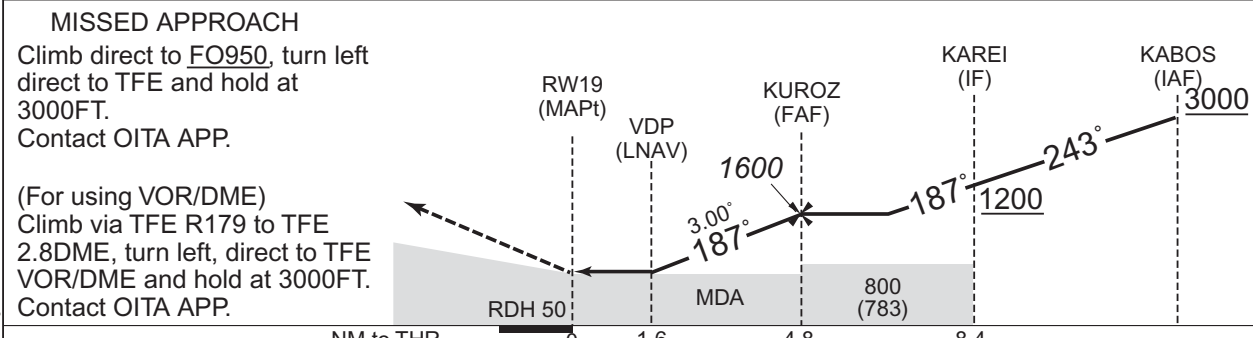

MINIMA	THR elev. 17	AD elev. 17
--------	--------------	-------------

CAT	LNAV/VNAV		LNAV		CIRCLING		
	DA(H)	CMV	MDA(H)	CMV	MDA(H)	VIS	
A	580 (563)	1400	580 (563)	1400	580 (563)	1600	
B		1500		1500			
C		1600		1600			690 (673)
D		1800		1800			760 (743)

Circling to EAST side of RWY only

CHANGE:PROC renamed. Requirement for RNP.

INSTRUMENT APPROACH CHART

RJFO / OITA

RNP RWY01(AR)

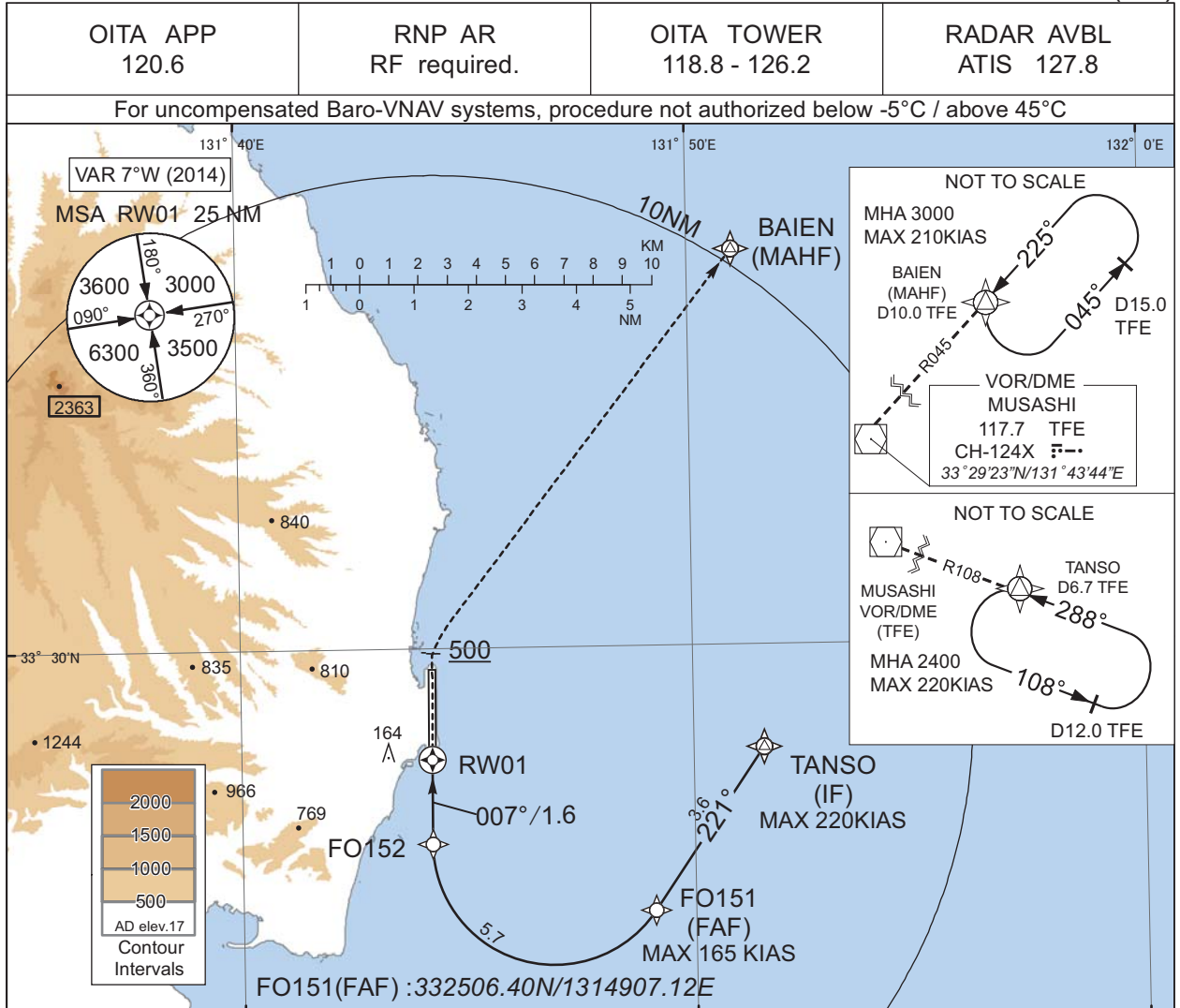

CHANGE : PROC renamed. Requirement for RNP:

MISSED APPROACH

From RW01 on track 007°, at or above 500FT turn right, direct to BAIEN and hold at 3000FT. Contact OITA APP.

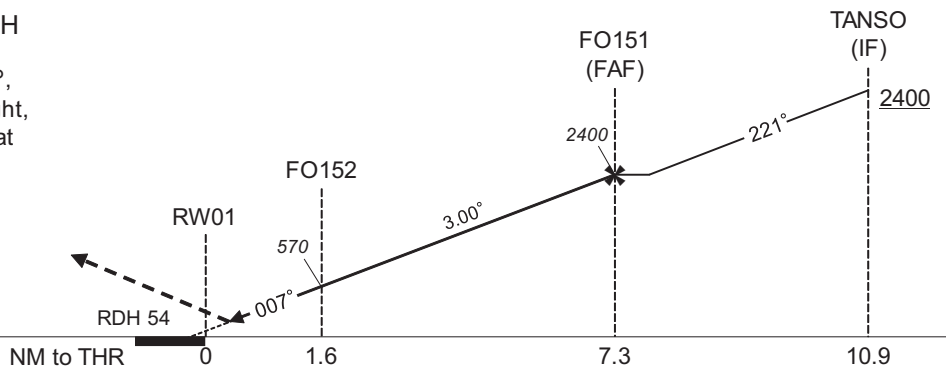

Missed APCH climb gradient MNM 5.0%

MINIMA	THR elev. 19	AD elev. 17
CAT	RNP 0.30	
	DA(H)	RVR/CMV
A	-	-
B	-	-
C	326(307)	1000
D	-	1400

Authorization Required

MINIMA with Missed APCH climb gradient of 2.5% are not established.

INSTRUMENT APPROACH CHART

RJFO / OITA

RNP RWY01(AR)

Coding Table

Serial Number	Path Descriptor	Waypoint Identifier	Fly Over	Course °M(°T)	Magnetic Variation	Distance (NM)	Turn Direction	Altitude (FT)	Speed (KIAS)	VPA/ RDH (°/FT)	RNP Value
001	IF	TANSO	-	-	-7.0	-	-	+2400	-220	-	-
002	TF	FO151	-	221 (214.2)	-7.0	3.6	-	2400	-165	-	1.0
003	RF Center: FORF1 r=2.25NM	FO152	-	-	-7.0	5.7	R	570	-	-3.00	0.3
004	TF	RW01	Y	007 (000.4)	-7.0	1.6	-	73	-	-3.00/54	0.3
005	FA	-	-	007 (000.4)	-7.0	-	-	+500	-	-	1.0
006	DF	BAIEN	-	-	-7.0	-	R	3000	-	-	1.0

Waypoint Coordinates

Waypoint Identifier	Coordinates	RF Arc Center Identifier	Coordinates
TANSO	332806.56N / 1315133.74E	FORF1	332622.64N / 1314653.79E
FO151	332506.40N / 1314907.12E		
FO152	332623.67N / 1314412.39E		
RW01	332757.53N / 1314413.22E		
BAIEN	333720.39N / 1315059.77E		

CHANGE : PROC renamed.

INSTRUMENT APPROACH CHART

RJFO / OITA

RNP Y RWY19(AR)

OITA APP 120.6	RNP AR RF required.	OITA TOWER 118.8 - 126.2	RADAR AVBL ATIS 127.8
-------------------	------------------------	-----------------------------	--------------------------

For uncompensated Baro-VNAV systems, procedure not authorized below -5°C / above 45°C

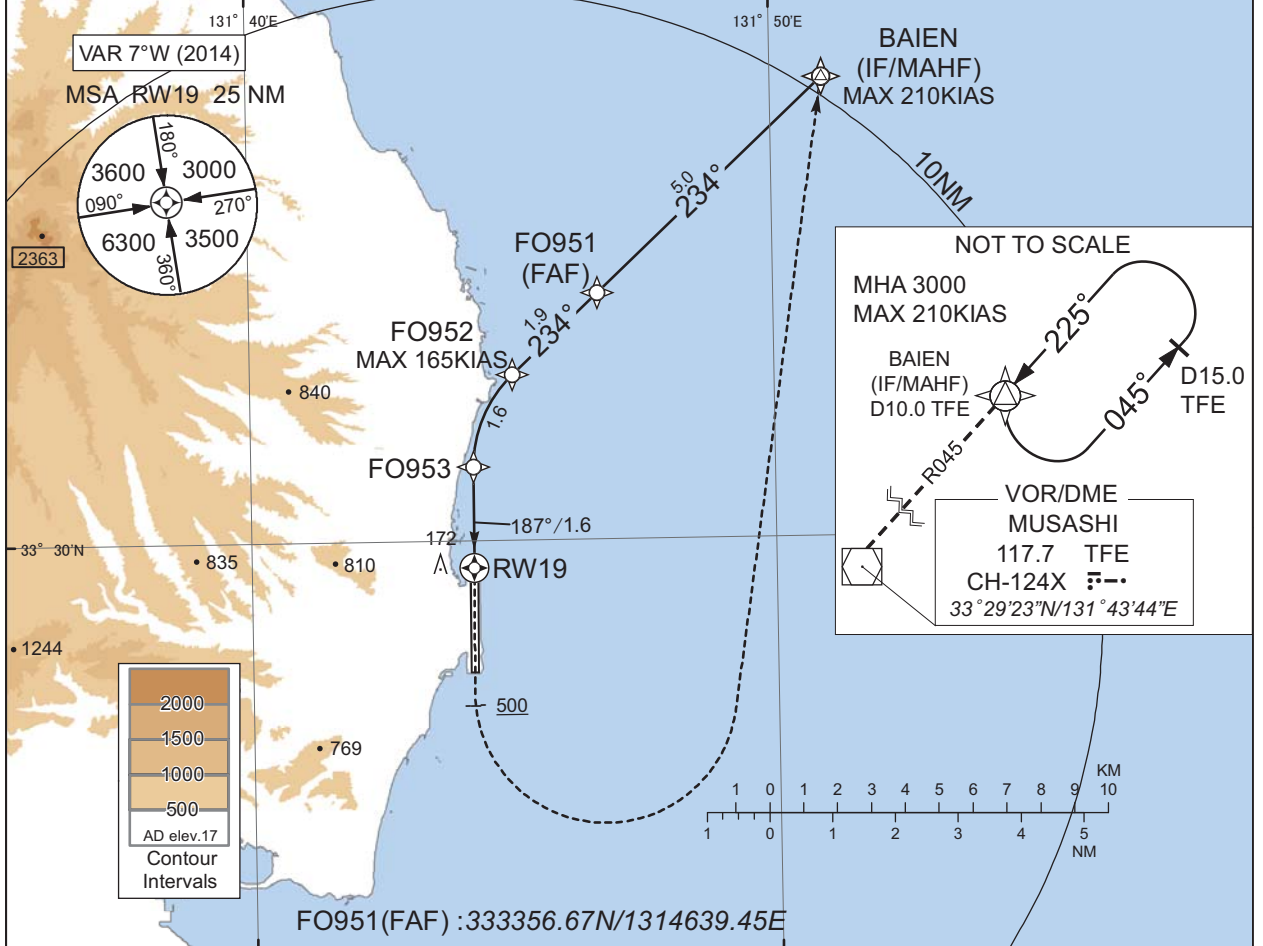

MISSED APPROACH

From RWY19 on track 187°, at or above 500FT turn left, direct to BAIEN and hold at 3000FT.
Contact OITA APP.

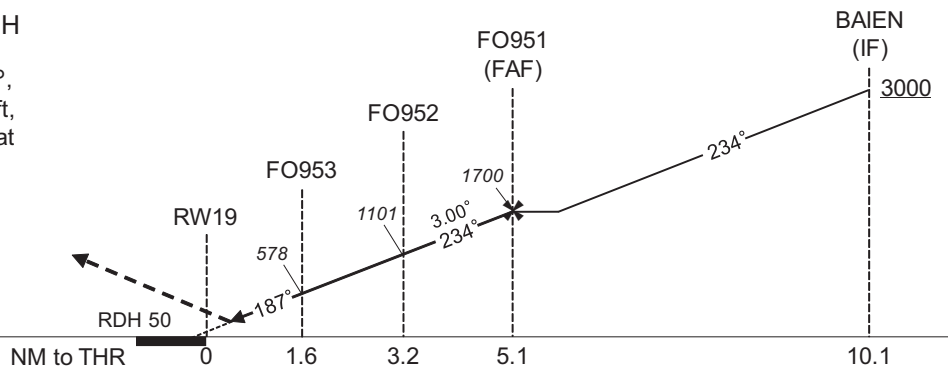

Missed APCH climb gradient MNM 5.0%

MINIMA	THR elev. 17 AD elev. 17	
	RNP 0.30	
CAT	DA(H)	CMV
A	-	-
B	-	-
C	334(317)	1400
D	-	1600

Authorization Required

MINIMA with Missed APCH climb gradient of 2.5% are not established.

CHANGE : PROC renamed. Requirement for RNP.

INSTRUMENT APPROACH CHART

RJFO / OITA

RNP Y RWY19(AR)

Coding Table

Serial Number	Path Descriptor	Waypoint Identifier	Fly Over	Course °M(°T)	Magnetic Variation	Distance (NM)	Turn Direction	Altitude (FT)	Speed (KIAS)	VPA/ RDH (°/FT)	RNP Value
001	IF	BAIEN	-	-	-7.0	-	-	+3000	-210	-	-
002	TF	FO951	-	234 (226.8)	-7.0	5.0	-	1700	-	-	1.0
003	TF	FO952	-	234 (226.8)	-7.0	1.9	-	1101	-165	-3.00	0.3
004	RF Center: FORF2 r=2.02NM	FO953	-	-	-7.0	1.6	L	578	-	-3.00	0.3
005	TF	RW19	Y	187 (180.4)	-7.0	1.6	-	67	-	-3.00/50	0.3
006	FA	-	-	187 (180.4)	-7.0	-	-	+500	-	-	1.0
007	DF	BAIEN	-	-	-7.0	-	L	3000	-	-	1.0

Waypoint Coordinates

Waypoint Identifier	Coordinates	RF Arc Center Identifier	Coordinates
BAIEN	333720.39N / 1315059.77E	FORF2	333110.65N / 1314640.11E
FO951	333356.67N / 1314639.45E		
FO952	333239.42N / 1314500.88E		
FO953	333111.58N / 1314414.94E		
RW19	332934.89N / 1314414.08E		

CHANGE : PROC renamed.

RJFO / OITA

Visual REP



※図中に標高を示す数字がある場合、単位はメートル(m)である。The unit of measurement used to express elevation is meter(m).

CHANGE : Map updated. BRG/DIST from ARP.

Call sign	BRG / DIST from ARP	Remarks
姫島 Himeshima	346°T / 15.3NM	島 Island
ゴルフコース Golf course	345°T / 9.7NM	ゴルフ場 Golf course
行入ダム Gyonyu dam	321°T / 7.0NM	ダム Dam
イーストポイント East point	090°T / 10.0NM	海上 Over the sea
杵築 Kitsuki	232°T / 6.7NM	八坂川河口 River mouth (The Yasaka)
佐賀関 Saganoseki	152°T / 15.0NM	精錬所煙突 Chimney

RJFO / OITA

Minimum Vectoring Altitude CHART

