

AD 2 AERODROMES

RJFU AD 2.1 AERODROME LOCATION INDICATOR AND NAME

RJFU - NAGASAKI

RJFU AD 2.2 AERODROME GEOGRAPHICAL AND ADMINISTRATIVE DATA

1	ARP coordinates and site at AD	325501N/1295449E
2	Direction and distance from (city)	18Km (9.7nm) NNE of Nagasaki railway station, 4km (2.2nm) W of Omura railway station.
3	Elevation/ Reference temperature	8ft / 33°C (2004-2008)
4	Geoid undulation at AD ELEV PSN	105.89ft
5	MAG VAR/ Annual change	7° W (2008) / Annual change 2' W
6	AD Administration, address, telephone, telefax, telex, AFS, e-mail and/or Web-site addresses	Civil Aviation Bureau, Ministry of Land, Infrastructure, Transport and Tourism Nagasaki Airport, 593-2 Mishima-cho, Omura City, Nagasaki Pref. Tel: 0957(53)6901 Fax: 0957(54)4539 AFS: RJFUZYX
7	Types of traffic permitted (IFR/VFR)	IFR/VFR
8	Remarks	Nil

RJFU AD 2.3 OPERATIONAL HOURS

1	AD Administration	2200 - 1300
2	Customs and immigration	Customs: 2330-0815 Immigration: INTL SKED FLT hours only
3	Health and sanitation	INTL SKED FLT hours only
4	AIS Briefing Office	2200 - 1300
5	ATS Reporting Office(ARO)	Nil
6	MET Briefing Office	H24 (FUKUOKA)
7	ATS	2200 - 1300 Remarks: 2200-2245 and 1215-1300, AFIS provided by Fukuoka Airport Office.
8	Fuelling	2200 - 1300
9	Handling	DOM/JAL:2240-1240, ANA:2200-1230, ORC:2200-0910 INTL/2330-0800
10	Security	2130 - 1200
11	De-icing	Nil
12	Remarks	Nil

RJFU AD 2.4 HANDLING SERVICES AND FACILITIES

1	Cargo-handling facilities	No limitation
2	Fuel/ oil types	Fuel Grades : JET A-1 Oil Grade : W80, W100, AERO80, AERO100
3	Fuelling facilities/ capacity	Fuel Truck Refueling, No limitation
4	De-icing facilities	Nil
5	Hangar space for visiting aircraft	Nil
6	Repair facilities for visiting aircraft	Nil
7	Remarks	Nil

RJFU AD 2.5 PASSENGER FACILITIES

1	Hotels	Hotels in the city
2	Restaurants	Available, Not Continuous
3	Transportation	Buses, Taxies and Ships
4	Medical facilities	Hospitals in the city
5	Bank and Post Office	Bank in the city. Post office in the city.
6	Tourist Office	Tourist Office in the city
7	Remarks	Nil

RJFU AD 2.6 RESCUE AND FIRE FIGHTING SERVICES

1	AD category for fire fighting	CAT 9
2	Rescue equipment	Chemical fire fighting truck x 3, Water supply truck x 1, Lighting power supply truck x 1, Emergency medical equipments conveyance truck x 1
3	Capability for removal of disabled aircraft	B744
4	Remarks	Nil

RJFU AD 2.7 SEASONAL AVAILABILITY-CLEARING

1	Types of clearing equipment	
2	Clearance priorities	1.RWY 2.TWY 3.APRON
3	Remarks	Seasonal availability:ALL seasons

RJFU AD 2.8 APRONS, TAXIWAYS AND CHECK LOCATIONS DATA

1	Apron surface and strength	Surface : Surface Concrete, Asphalt Concrete in part. Strength : PCN 56/R/A/X/T spot NR 2 PCN 52/R/B/X/T spot NR 3 PCN 70/R/B/X/T spot NR 5 PCN 70/R/A/X/T spot NR 6 PCN 62/R/B/X/T spot NR 7, 8, 9, 10 PCN 74/R/B/X/T spot NR 11, 12, 14 N-Apron(Small ACFT Apron) Surface : Asphalt, Strength : AUW 5700Kg/0.48Mpa
2	Taxiway width, surface and strength	Width : B2.....9m P1 - P5.....23m T1, T6.....28.5m T2, T3, T4, T5....34m Surface : Asphalt Concrete Strength : B2.....PCN 5/F/C/X/T P1, P3, P4, T1...PCN 65/F/A/X/T P5, T6.....PCN 97/F/C/X/T T2, T3, T4, T5....PCN 54/F/A/X/T P2.....PCN 62/R/B/X/T
3	ACL and elevation	Not available
4	VOR checkpoints	Not available
5	INS checkpoints	Spot NR 5 : 325447.08N/1295522.18E* 6 : 325448.42N/1295520.75E 7 : 325449.91N/1295519.11E 8 : 325451.60N/1295517.31E 9 : 325453.29N/1295515.51E 10 : 325454.98N/1295513.71E 11 : 325456.73N/1295511.84E 12 : 325458.53N/1295509.91E
6	Remarks	Nil

RJFU AD 2.9 SURFACE MOVEMENT GUIDANCE AND CONTROL SYSTEM AND MARKINGS

1	Use of aircraft stand ID signs, TWY guide lines and Visual docking/ parking guidance system of aircraft stands	ACFT stand ID signs: SPOT 2, 5-9
2	RWY and TWY markings and LGT	<p>RWY14/32: (Marking) RWY designation, RWY CL, RWY THR, Aiming point, TDZ, RWY side stripe (LGT) RCLL, REDL, RTHL, RENL, RTZL(RWY32), WBAR(RWY32), RWY DIST marker LGT</p> <p>TWY: T1 - T6 (Marking) TWY CL, RWY HLDG PSN, Mandatory Instructions, TWY side stripe (LGT) TWY edge LGT, TWY CL LGT, RWY guard LGT, Taxiing guidance sign</p> <p>TWY: P1, P3, P4, P5 (Marking) TWY CL, TWY side stripe (LGT) TWY edge LGT, TWY CL LGT</p> <p>TWY: P2 (Marking) TWY CL, TWY side stripe (LGT) TWY edge LGT, TWY CL LGT, Taxiing guidance sign</p> <p>TWY: B2 (Marking) TWY CL, TWY side stripe (LGT) TWY edge LGT, Taxiing guidance sign</p>
3	Stop bars	Nil
4	Remarks	(Marking) Overrun area (LGT) Apron flood LGT

RJFU AD 2.10 AERODROME OBSTACLES

- In Area2 See Obstacle data
- In Area3 To be developed

RJFU AD 2.11 METEOROLOGICAL INFORMATION PROVIDED

1	Associated MET Office	FUKUOKA
2	Hours of service MET Office outside hours	H24 (FUKUOKA)
3	Office responsible for TAF preparation Periods of validity	FUKUOKA 30 Hours
4	Trend forecast Interval of issuance	Nil
5	Briefing/ consultation provided	Briefing is available upon inquiry at FUKUOKA
6	Flight documentation Language(s) used	C En
7	Charts and other information available for briefing or consultation	S ₆ , U ₈₅ , U ₇ , U ₅ , U ₃ , U ₂₅ , P _s , P ₅ , P ₃ , P ₂₅ , P _{SWE} , P _{SWF} , P _{SWG} , P _{SWI} , P _{SWM} , P _{SW} (domestic), U ₂ /Tr, E, C, W _E , W _F , W _G , W _I , W, N
8	Supplementary equipment available for providing information	Nil
9	ATS units provided with information	TWR, APP, ATIS, RADIO
10	Additional information(limitation of service, etc.)	Nil

RJFU AD 2.12 RUNWAY PHYSICAL CHARACTERISTICS

Designations RWY NR	TRUE BRG	Dimensions of RWY(M)	Strength(PCN) and surface of RWY	THR coordinates THR geoid undulation	THR elevation and highest elevation of TDZ of precision APP RWY
1	2	3	4	5	6
14	138.00°	3000x60	PCN 65/F/A/X/T Asphalt Concrete	325537.28N 1295409.77E 105.8ft	THR ELEV: 14ft
32	318.00°	3000x60	PCN 65/F/A/X/T Asphalt Concrete	325424.91N 1295527.04E 106.0ft	THR ELEV: 15ft

Slope of RWY	Strip Dimen- sions(M)	RESA (Overrun) Dimensions (M)	Remarks
7	10	11	14
See below chart	3120x300	40x300	RWY 14 grooving: 3000 x 40m
See below chart	3120x300	190x(MNM:120 MAX:300)* *For detail, ask airport administrator	RWY 32 grooving: 3000 x 40m

RJFU AD 2.13 DECLARED DISTANCES

RWY Designator	TORA (m)	TODA (m)	ASDA (m)	LDA (m)	Remarks
1	2	3	4	5	6
14	3000	3000	3000	3000	Nil
TWY:T5	2488	2488	2488		
TWY:T4	1875	1875	1875		
32	3000	3000	3000	3000	Nil
TWY:T2	2603	2603	2603		
TWY:T3	1750	1750	1750		

誘導路の TORA, TODA 及び ASDA は、誘導路中心線と滑走路中心線の交点から滑走路末端までの距離を示す。
(TORA, TODA and ASDA for TWY indicate distances BTN the point where TWY CL meets RWY CL and RWY THR.)

RJFU AD 2.14 APPROACH AND RUNWAY LIGHTING

RWY Designator	APCH LGT type LEN INTST	RTHL Color WBAR	PAPI (VASIS) Angle DIST FM THR MEHT	RTZL LEN	RCLL LEN Spacing Color INTST	REDL LEN Spacing Color INTST	RENL Color WBAR	STWL LEN Color
1	2	3	4	5	6	7	8	9
14	SALS (*1) 420m LIH	Green -	PAPI 3.0°/LEFT 471m 74ft	-	3000m 30m Coded color (White/Red) LIH	3000m 60m Coded color (White/Yellow) LIH	Red	Nil (*2)
32	PALS (CAT I) 900m LIH	Green Green	PAPI 3.0°/LEFT 444m 65ft	900m	3000m 30m Coded color (White/Red) LIH	3000m 60m Coded color (White/Yellow) LIH	Red	Nil (*2)
Remarks								
10								
SALS with APCH LGT beacon(595m and 895m FM RWY THR)(*1) Overrun area edge LGT(LEN:60m Color:Red)(*2)								

RJFU AD 2.15 OTHER LIGHTING, SECONDARY POWER SUPPLY

1	ABN/IBN location, characteristics and hours of operation	ABN: 325428N/1295457E, White/Green EV4.3sec, HO
2	LDI location and LGT Anemometer location and LGT	LDI : Nil Anemometer : RWY 32 : 438m from RWY 32 THR, LGTD RWY 14 : 430m from RWY 14 THR, LGTD
3	TWY edge and centerline lighting	TWY edge and center line lights installed, see AD2.9
4	Secondary power supply/ switch-over time	Within 1 sec : REDL, RENL, RTHL, WBAR, RCLL, Overrun area edge LGT Within 15 sec : Other LGT
5	Remarks	WDI LGT

RJFU AD 2.16 HELICOPTER LANDING AREA

Nil

RJFU AD 2.17 ATS AIRSPACE

Designation and lateral limits		Vertical limits (ft)	Airspace classification	ATS unit call sign Language	Remarks
1		2	3	4	6
NAGASAKI CTR	Area within a radius of 5 nm of NAGASAKI ARP (325501N1295449E)	3,000 or below	D	NAGASAKI TWR NAGASAKI RADIO (1) En	(1)2200-2245 1215-1300
NAGASAKI ACA	See attached chart		E	NAGASAKI APP NAGASAKI RADAR NAGASAKI DEP En	
NAGASAKI TCA	See attached chart		E	NAGASAKI TCA En	

長崎進入管制区
Nagasaki Approach Control Area

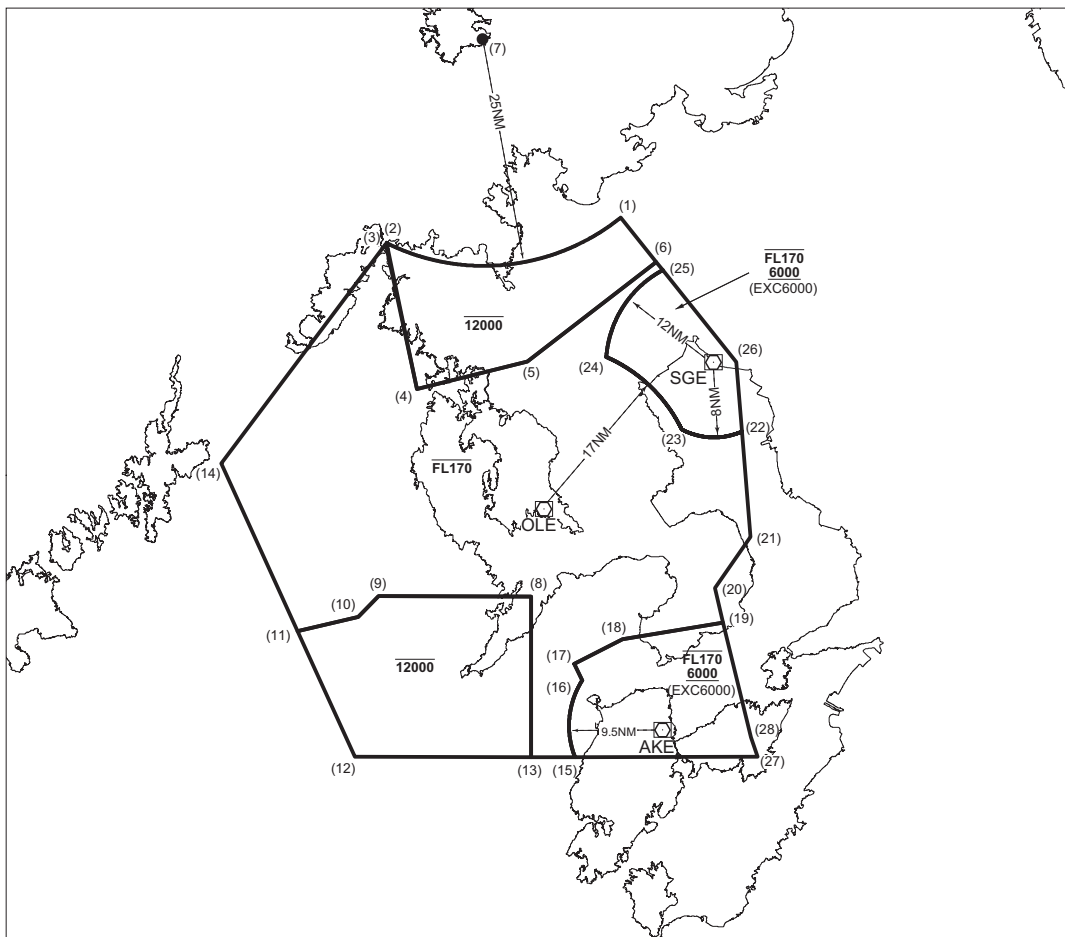

Point list

- | | | |
|----------------------|----------------------|----------------------|
| (1) 332519N1300516E | (11) 323917N1292246E | (21) 324950N1302218E |
| (2) 332227N1293413E | (12) 322522N1293021E | (22) 330132N1302113E |
| (3) 332219N1293406E | (13) 322522N1295325E | (23) 330147N1301316E |
| (4) 330615N1293818E | (14) 325752N1291235E | (24) 330951N1300318E |
| (5) 330921N1295252E | (15) 322522N1295913E | (25) 331929N1301048E |
| (6) 332024N1300955E | (16) 323353N1300008E | (26) 330915N1302028E |
| (7) 334508N1294656E | (17) 323544N1295905E | (27) 322522N1302306E |
| (8) 324312N1295325E | (18) 323828N1300526E | (28) 322734N1302215E |
| (9) 324312N1293323E | (19) 324018N1301840E | |
| (10) 324053N1293041E | (20) 324407N1301735E | |

長崎ターミナルコントロールエリア
Nagasaki Terminal Control Area

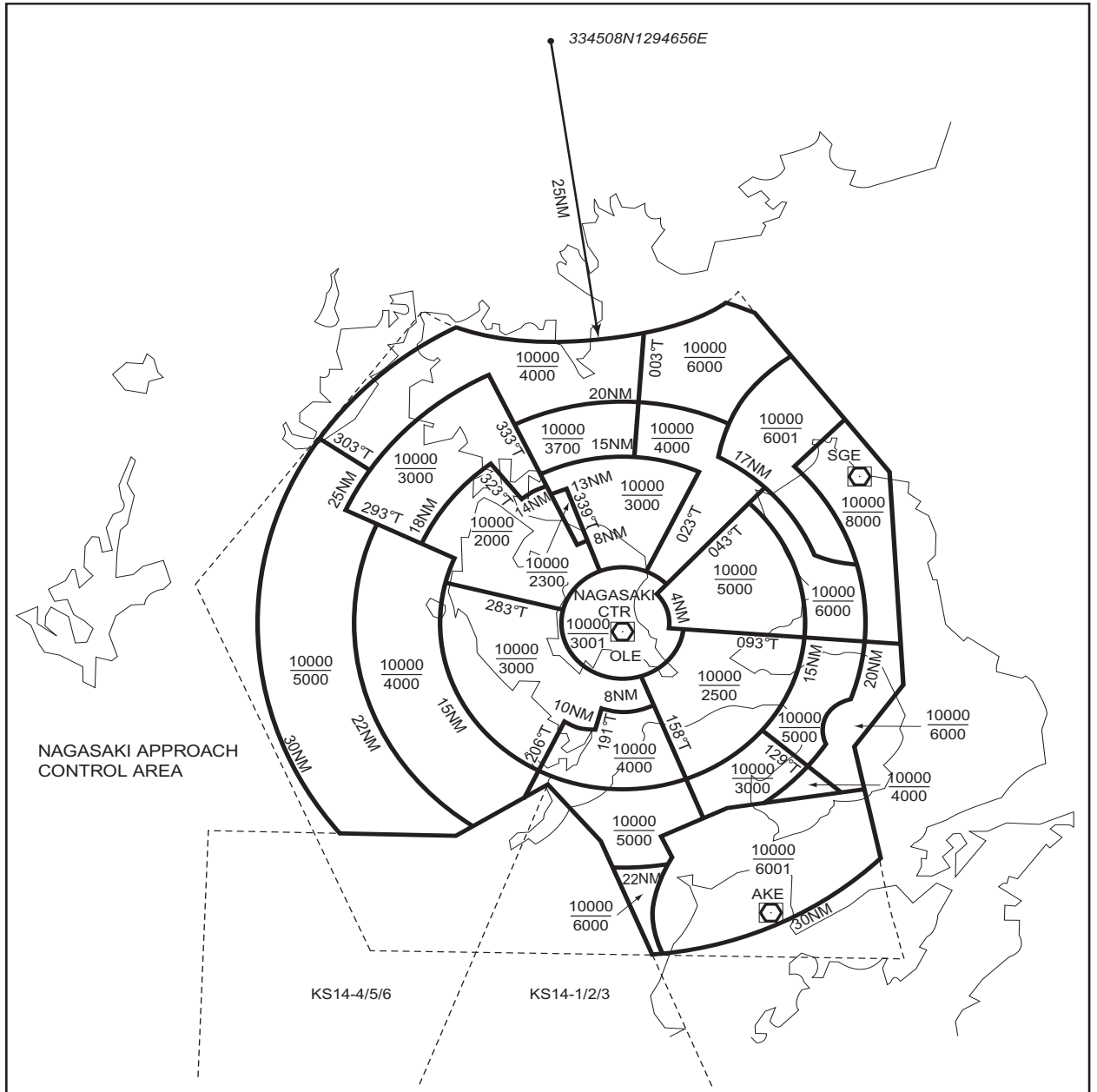

RJFU AD 2.18 ATS COMMUNICATION FACILITIES

Service designation	Call sign	Frequency	Hours of operation	Remarks
1	2	3	4	5
APP	Nagasaki Approach	119.175MHz(1) 261.2MHz 121.5MHz(E) 243.0MHz(E)	2200 - 1300	(1)Primary
ASR	Nagasaki Radar	119.175MHz 121.025MHz 261.2MHz 121.5MHz(E) 243.0MHz(E)	2200 - 1300	
DEP	Nagasaki Departure	121.0MHz 261.2MHz 121.5MHz(E) 243.0MHz(E)	2200 - 1300	
TCA	Nagasaki TCA	121.175MHz 245.3MHz	2300 - 1030	
TWR	Nagasaki Tower	118.5MHz 126.2MHz 122.7MHz 236.8MHz 121.5MHz(E) 243.0MHz(E)	2245 - 1215(*)	
GND	Nagasaki Ground	121.6MHz	2245 - 1215(*)	
ATIS	NAGASAKI Airport	126.85MHz	2200 - 1300	
AFIS	Nagasaki Radio	118.5MHz	2200-2245 1215-1300(*)	Operated by Fukuoka Airport Office

*Depending on air traffic situation, ATC service will be provided from 2230 to 2245 and from 1215 to 1230.

RJFU AD 2.19 RADIO NAVIGATION AND LANDING AIDS

Type of aid (VOR declination)	ID	Frequency	Hours of operation	Position of transmitting antenna coordinates	Elevation of DME transmitting antenna	Remarks
1	2	3	4	5	6	7
VOR (7°W/2020)	OLE	116.6MHz	H24	325418.89N/ 1295504.73E		VOR unusable : 040°-070° beyond 25nm BLW 6000ft 070°-090° beyond 20nm BLW 6000ft
DME	OLE	1200 MHz (CH-113X)	H24	325418.89N/ 1295504.73E	154ft	DME unusable : 030°-070° beyond 20nm BLW 6000ft 070°-090° beyond 15nm BLW 6000ft 160°-170° beyond 30nm BLW 5000ft 170°-200° beyond 20nm BLW 4000ft 200°-210° beyond 10nm BLW 4000ft 210°-240° beyond 20nm BLW 4000ft 260°-300° beyond 20nm BLW 4000ft
ILS-LOC 32	IOL	110.9MHz	2200 - 1300	325542.95N/ 1295403.71E		LOC : 235m(771ft) away FM RWY 14THR, BRG(MAG)325°.
ILS-GP 32	-	330.8MHz	2200 - 1300	325430.22N/ 1295515.11E		GP : 330m(1084ft) inside FM RWY 32 THR. 120m SW of RCL. HGT of ILS Ref datum 16.2m(53ft). GP Angle 3.0°.
ILS-DME 32	IOL	1007MHz (CH-46X)	2200 - 1300	325429.87N/ 1295514.76E	25ft	DME : 330m(1084ft) inside FM RWY 32 THR,134m(439ft) SW of RCL.
MSAS		1575.42M Hz	H24			Transmitting antennas are satellite based.

ILS

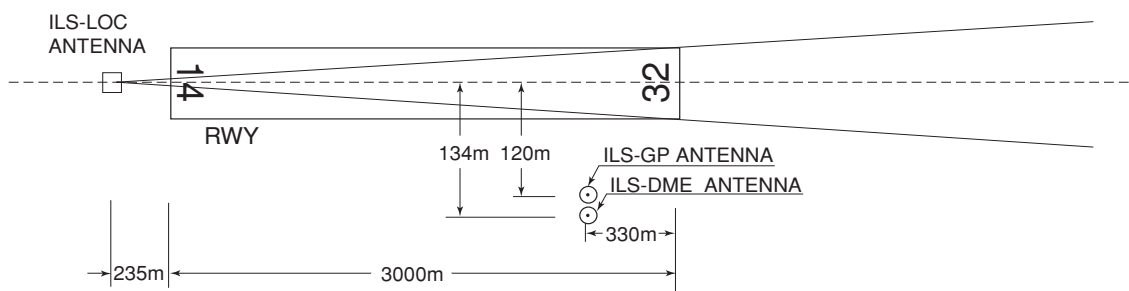

REMARKS : 1. LOC beam BRG(MAG) 325°
2. HGT of ILS REF datum 16.2m (53ft)
3. GP Angle 3.0°
4. ELEV of ILS-DME 7.6m (25ft)

RJFU AD 2.20 LOCAL TRAFFIC REGULATIONS

1. Airport regulations

1.1 Without prior permission of the airport administrator, the transient aircraft shall not use on this airport.

1.2 Prior notification should be required with AD Administration for the purpose of getting the permission when crossing Nagasaki CTR from 2200UTC to 2245UTC or from 1215UTC to 1300UTC.
 For further information (0000UTC-0800UTC MON-FRI EXC HOL)
 Air Traffic Controller Office, Nagasaki Airport Office
 TEL: 0957-53-6870

7時00分から7時45分または21時15分から22時00分までの間、長崎管制圏を通過する場合は、当該通過の許可を得るためにあらかじめ長崎空港事務所へ調整すること。
 問い合わせ先
 長崎空港事務所管制官事務室
 (月曜日から金曜日までのうち、9時00分から17時00分までの間。ただし休日を除く。)
 TEL: 0957-53-6870

2. Taxiing to and from stands

<p>2.1 駐機位置について スポット 2A の駐機位置は以下の通りとする。 また自走アウトの際は以下に従うこと。</p> <p>1) 自走アウトは以下図の駐機位置から左旋回とする。 ※隣接のスポット 3 は右旋回となるので注意する。</p> <p>2) スポット 2A とスポット 3 の同時走行は不可。</p>	<p>2.1 The parking position of Spot 2A shall be as follows. Also, operators shall comply with the following power-out procedure.</p> <p>1) The power-out procedure is a left turn from the parking position. *Caution that the next spot 3 turns right.</p> <p>2) Spot 2A and Spot 3 cannot be taxi to and from stands at the same time.</p>
---	---

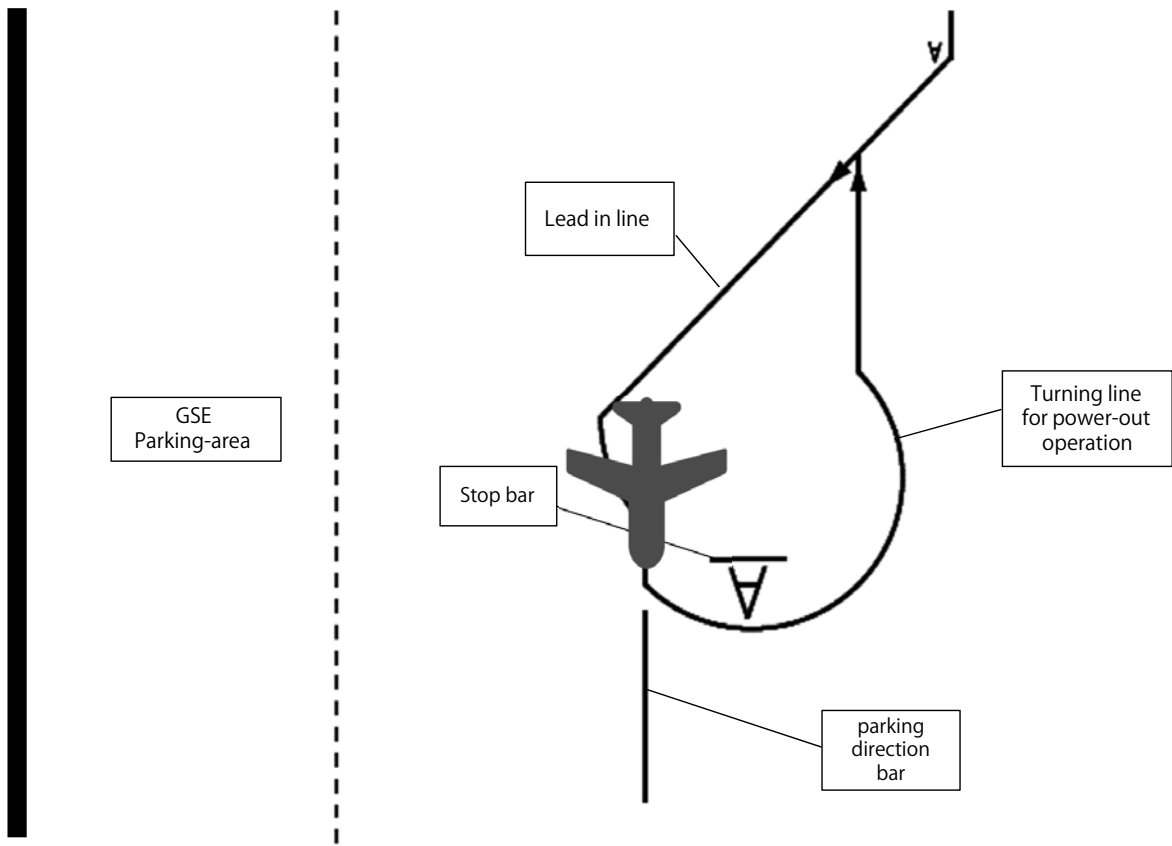

<p>2.2 プッシュバック方式について スポット 5.6.7.8.9 は、小型ジェット機に限りショートプッシュバックが実施できる。詳細は空港管理者に確認すること及び管制指示に従うこと。 ※ 但し、外国航空会社によるショートプッシュバックは実施不可 * 1) 小型ジェット機・・・B738、A321 以下 * 2) ショートプッシュバック ・・・・エプロン境界線からターミナル側 23.0m の位置に標示された白の実線にノーズギアを乗せて行う方法。</p>	<p>2.2 Push back procedure Spot 5.6.7.8.9 can be short-pushback only for small jets. Ask AD administration for detail and follow the ATC instructions. *Short pushback by foreign airlines is not possible. *1) Small jets ...B738, A321 or less. *2) Short-pushback ...The procedure is performed by placing the nose gear on the white line marked 23.0m on the terminal side from the apron boundary line.</p>
---	--

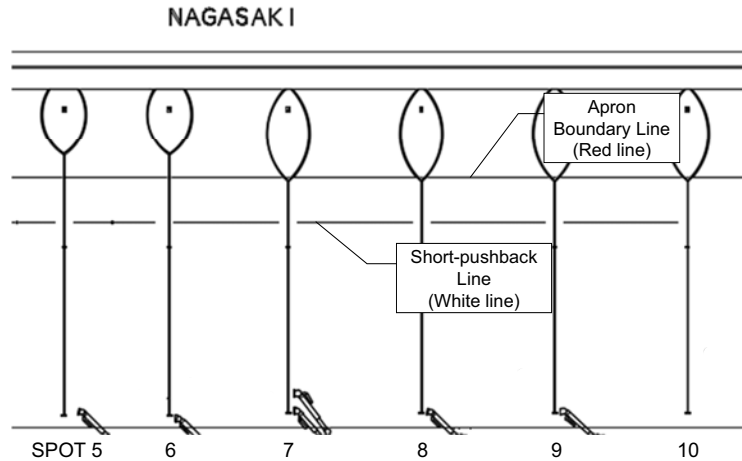

3. Parking area for small aircraft(General aviation)

<p>3.1 Unable to stay at spot NR 2B, 2C and 2D from sunset to sunrise. Ask AD administration for detail. 3.2 Unable to refueling at spot NR N2 and N3.</p>

4. Parking area for helicopters

Nil

5. Apron - taxiing during winter conditions

Nil

6. Taxiing - limitations

<p>Wing tip clearance at the TWY intersection (REF AD1.1.6.8) Wing tip clearance at the TWY intersection between the aircraft holding at the stop marking on the TWY and the other aircraft taxiing behind it are as follows.</p>			
<p>When B773 holding at the stop marking on TWY T2 or T5</p>			
Wing span (WS) of aircraft taxiing on TWY P1-P2 or P4-P5	WS ≤ 30.1m	30.1m < WS ≤ 47.1m	WS > 47.1m
wing tip clearance	*A	*B	*C

Legend
 *A : wing tip clearance ≥ 15m
 *B : 6.5m ≤ wing tip clearance < 15m
 *C : wing tip clearance < 6.5m

7. School and training flights - technical test flights - use of runways

On use of this airport by training operation, the operator is required to arrange and obtain the prior permission of the airport administrator.

8. Helicopter traffic - limitation

Nil

9. Removal of disabled aircraft from runways

Nil

RJFU AD 2.21 NOISE ABATEMENT PROCEDURES

Nil

RJFU AD 2.22 FLIGHT PROCEDURES**1. TAKE OFF MINIMA**

	RWY	ACFT CAT	REDL & RCLL		REDL or RCLL or RCL Marking		NIL (DAYTIME ONLY)	
			RVR	VIS	RVR	VIS	RVR	VIS
Multi-Engine ACFT with TKOF ALTN AP FILED	14	A,B,C,D	-	400m	-	400m	-	500m
	32		400m	400m	400m	400m	-	500m
OTHER	14	A,B,C,D	AVBL LDG MINIMA					
	32							

2. Lost communication procedures for Arrival Aircraft under radar navigational guidance.

If radio communications with NAGASAKI Approach/Radar are lost for 30 seconds, squawk Mode A/3 Code 7600 and :

- (I) 1. Contact NAGASAKI Tower / NAGASAKI Radio.
2. If unable, proceed in accordance with Visual Flight Rules.
3. If unable, proceed to NAGASAKI VOR/DME at last assigned altitude or 4,000 feet whichever is higher, and execute instrument approach.
- (II) Procedures other than above will be issued when situation required.

3. Trajectorized Airport Traffic Data Processing System (TAPS)

Aircraft flying under control of Nagasaki approach control in the approach control area will be instructed to reply with discrete code on Mode A/3 and Mode C.

If an aircraft with non-discrete capability be instructed to reply with the discrete code, it shall report a controller accordingly.

長崎アプローチの指示のもとに、当該進入管制区を飛行する航空機は、モード A/3 の二次レーダー個別コード及びモード C による応答を指示される。
二次レーダー個別コードを搭載していない航空機が当該コードによる応答を指示された場合は、管制官に対しその旨通報すること。

RJFU AD 2.23 ADDITIONAL INFORMATION

Nil

RJFU AD 2.24 CHARTS RELATED TO AN AERODROME

Aerodrome/Heliport Chart
Aerodrome Obstacle Chart -ICAO type A (RWY 14/32)
Aerodrome Obstacle Chart -ICAO type B
Standard Departure Chart - Instrument (NORTH)
Standard Departure Chart - Instrument (WEST)
Standard Departure Chart - Instrument (NAGASAKI REVERSAL)
Standard Departure Chart - Instrument (CHIKUGO-RNAV)
Standard Departure Chart - Instrument (KAZSA-RNAV)
Standard Departure Chart - Instrument (AKNAG-RNAV)
Standard Departure Chart - Instrument (CARCO-RNAV)
Standard Arrival Chart - Instrument (RNAV)
Instrument Approach Chart (ILS Z or LOC Z RWY 32)
Instrument Approach Chart (ILS Y or LOC Y RWY 32)
Instrument Approach Chart (RNP RWY 32)
Instrument Approach Chart (RNP RWY 14)
Instrument Approach Chart (VOR RWY 32)
Instrument Approach Chart (VOR RWY 14)
Other Chart (Visual REP)
Other Chart (LDG CHART)
Other Chart (HOLDING PATTERN)
Other Chart (MVA CHART)

INTENTIONALLY LEFT BLANK

INTENTIONALLY LEFT BLANK

DIMENSIONS AND ELEVATIONS IN FEET BEARINGS ARE MAGNETIC
Transverse Mercator Projection

AERDROME OBSTACLE CHART - ICAO
TYPE A (OPERATING LIMITATIONS)

MAGNETIC VARIATION 8°W - JUN 2023

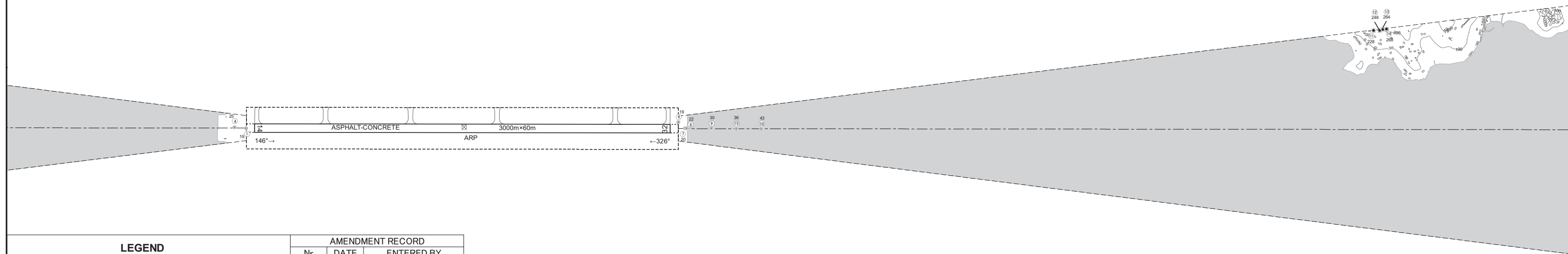
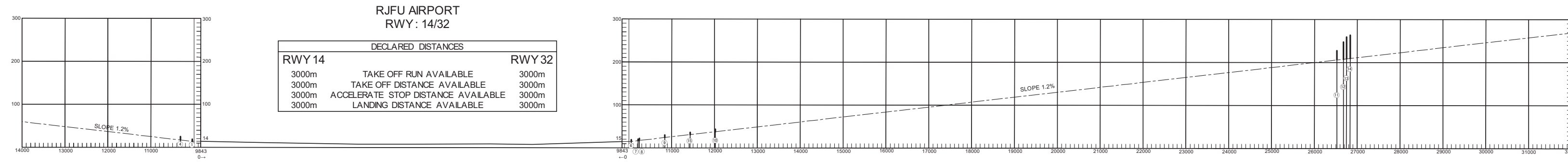

LEGEND	AMENDMENT RECORD		
	Nr	DATE	ENTERED BY
① IDENTIFICATION NUMBER			
⊙ POLE, TOWER, SPIRE, ANTENNA, ETC			
✳ TREE ▨ LEVEE			
⊢⊢⊢ RAILROAD ~ RIVER			
△ TRIANGULATION POINT			
★ AERONAUTICAL GROUND LIGHT			
■ BUILDING OR LARGE STRUCTURE			
〰 CONTOURS(ft)			

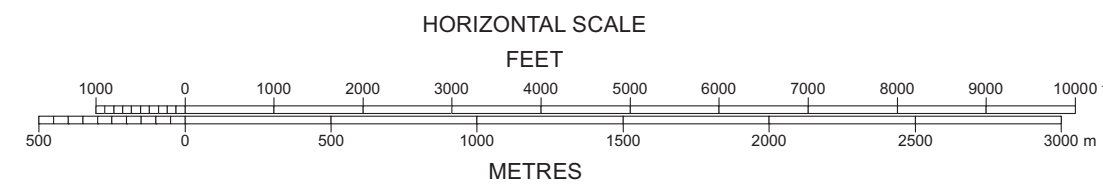

CHANGE: Update

測量法に基づく国土地理院長承認(使用) R 4JHs 286

STANDARD DEPARTURE CHART -INSTRUMENT

RJFU / NAGASAKI

SID

NORTH ONE DEPARTURE

RWY 14: Climb RWY HDG to 500FT, via OLE R144 to 6.0 DME, turn right HDG324° until crossing OLE R258, turn right HDG016° to intercept and proceed via OLE R331 to PEARL....

RWY 32: Climb via OLE R331 to PEARL....

... Cross PEARL at or above 6000FT(*).

* For FUKUOKA TRANSITION : Cross PEARL at or above 8000FT.

Note RWY 14: 5.0% climb gradient required up to 1200FT.

OBST ALT 1411FT located at 6.9NM 158° FM end of RWY14.

OBST ALT 1575FT located at 7.7NM 165° FM end of RWY14.

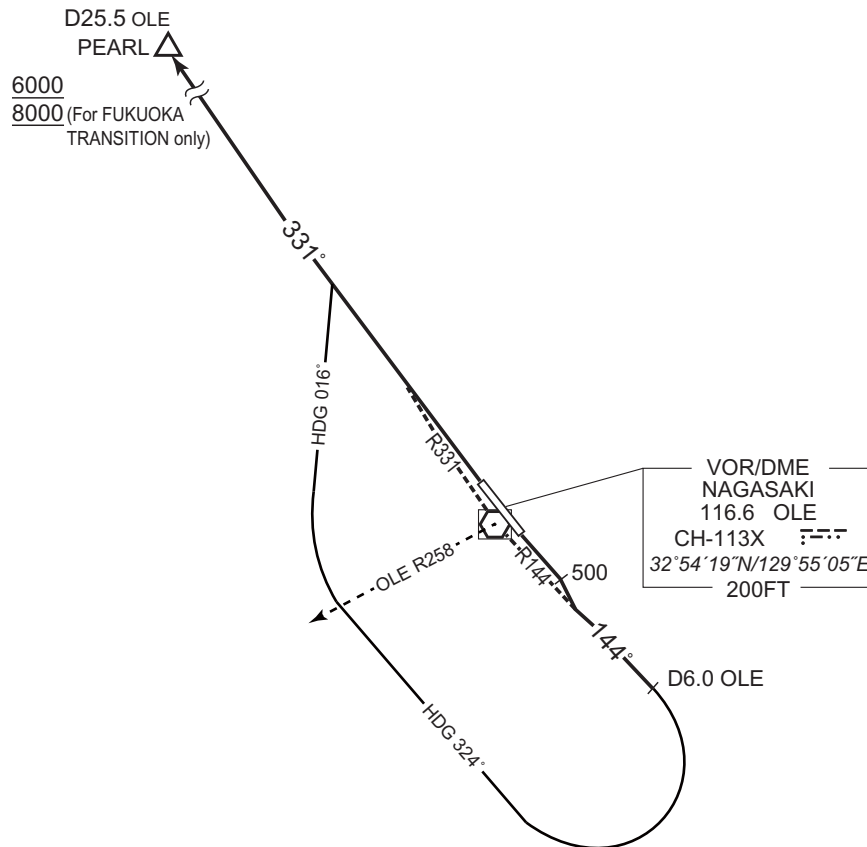

CHANGE: Description of PROC name.

STANDARD DEPARTURE CHART -INSTRUMENT

RJFU / NAGASAKI

TRANSITION

FUKUOKA TRANSITION

From over PEARL, via DGC R244 to DGC VORTAC.
Note : Not applicable for aircraft equipped with TACAN only.

IKI TRANSITION

From over PEARL, via IKE R203 to IKE VOR/DME.

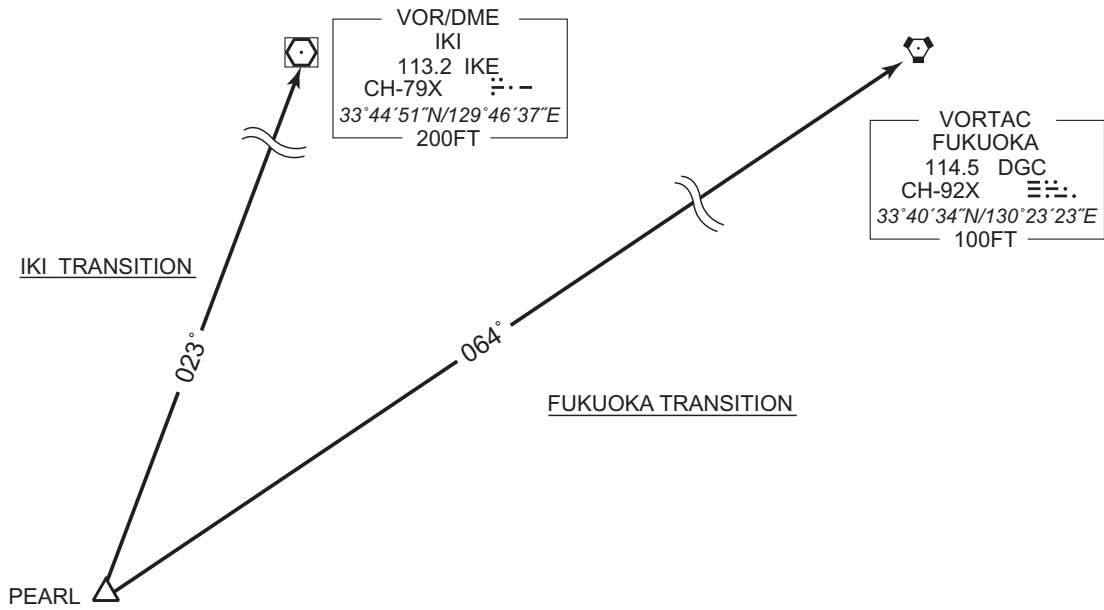

CHANGE : Course FM PEARL to IKE.

STANDARD DEPARTURE CHART -INSTRUMENT

RJFU / NAGASAKI

SID

WEST SEVEN DEPARTURE

RWY 14: Climb RWY HDG to 500FT, climb via OLE R144 to 1800FT,
turn right HDG292° to intercept and proceed via OLE R247...

RWY 32: Climb RWY HDG 1500FT, turn left HDG202° to intercept
and proceed via OLE R247...

... to SUMOU.

Cross SUMOU at or above 4000FT.

Note RWY 14: 5.0% climb gradient required up to 1800FT.

OBST ALT 854FT located at 3.4NM 170° FM end of RWY14.

RWY 32: 5.0% climb gradient required up to 1500FT.

OBST ALT 1969FT located at 8.0NM 272° FM end of RWY32.

CHANGE : Description of PROC name.

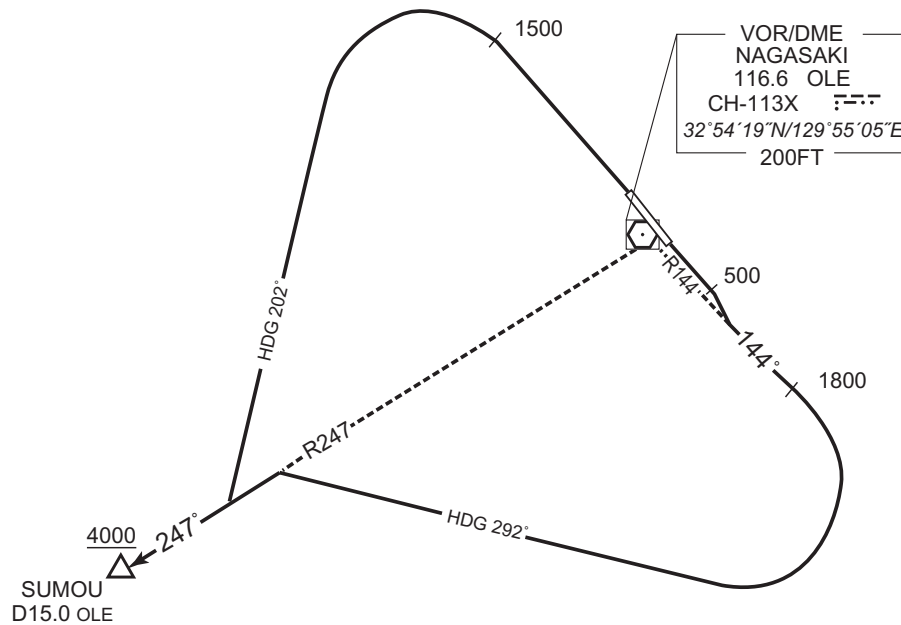

STANDARD DEPARTURE CHART -INSTRUMENT

RJFU / NAGASAKI

TRANSITION

OMURA TRANSITION

From over SUMOU, turn right to intercept and proceed via OLE R279 to OLE VOR/DME.

Maintain 12000FT or below until intercepting OLE R279.
Cross OLE R279/13.0DME at or above 9000FT.

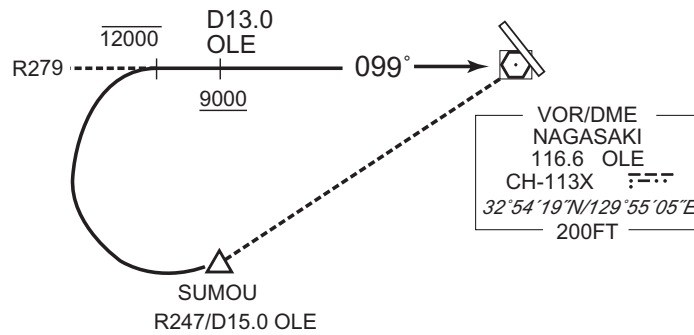

CARCO TRANSITION

From over SUMOU, turn right HDG308° to intercept and proceed via OLE R263 /FUE R082 to CARCO.

Maintain 12000FT or below until intercepting OLE R263.

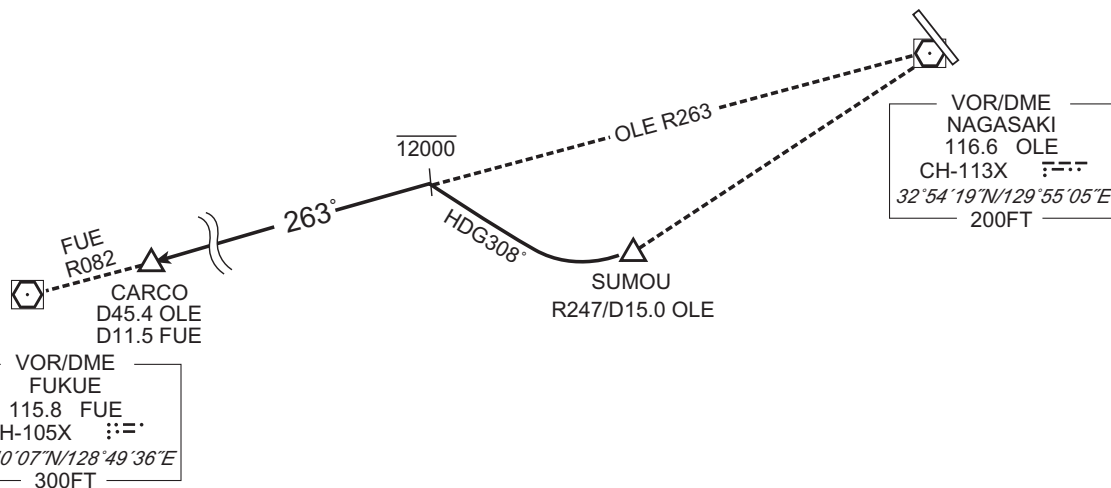

CHANGE : Description of PROC name.

STANDARD DEPARTURE CHART -INSTRUMENT

RJFU / NAGASAKI

SID

NAGASAKI REVERSAL FIVE DEPARTURE

RWY 14: Climb RWY HDG to 500FT, climb via OLE R144 to 6.0DME, turn right, direct to OLE VOR/DME.
Cross OLE VOR/DME at or above 5000FT.

RWY 32: Climb via OLE R331 to 6.3DME, turn left, direct to OLE VOR/DME.
Cross OLE VOR/DME at or above 5000FT.

Note RWY 14: 5.0% climb gradient required up to 1800FT.
OBST ALT 1575FT located at 7.7NM 165° FM end of RWY14.
RWY 32: 5.0% climb gradient required up to 1600FT.
OBST ALT 1969FT located at 8.0NM 272° FM end of RWY32.

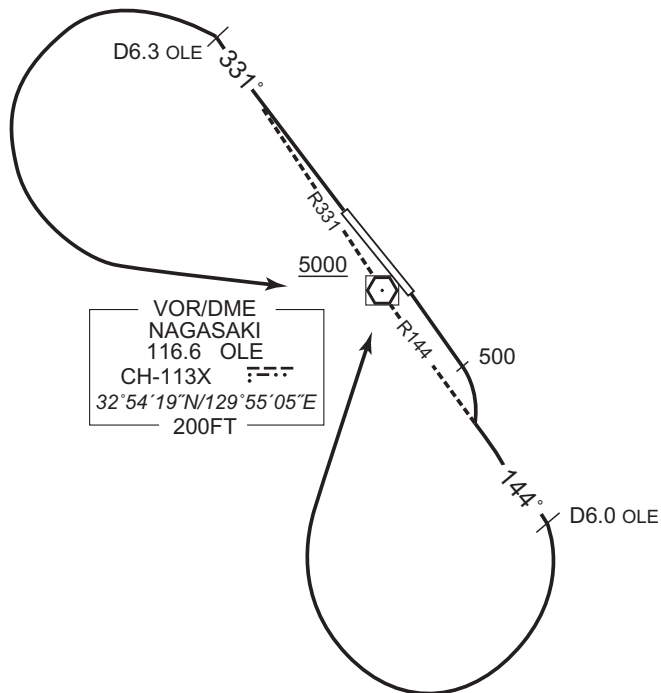

CHANGE : Description of PROC name.

STANDARD DEPARTURE CHART -INSTRUMENT

RJFU / NAGASAKI

RNAV SID

CHIKUGO FIVE DEPARTURE

RNP1

Note GNSS required.

VAR 8° W

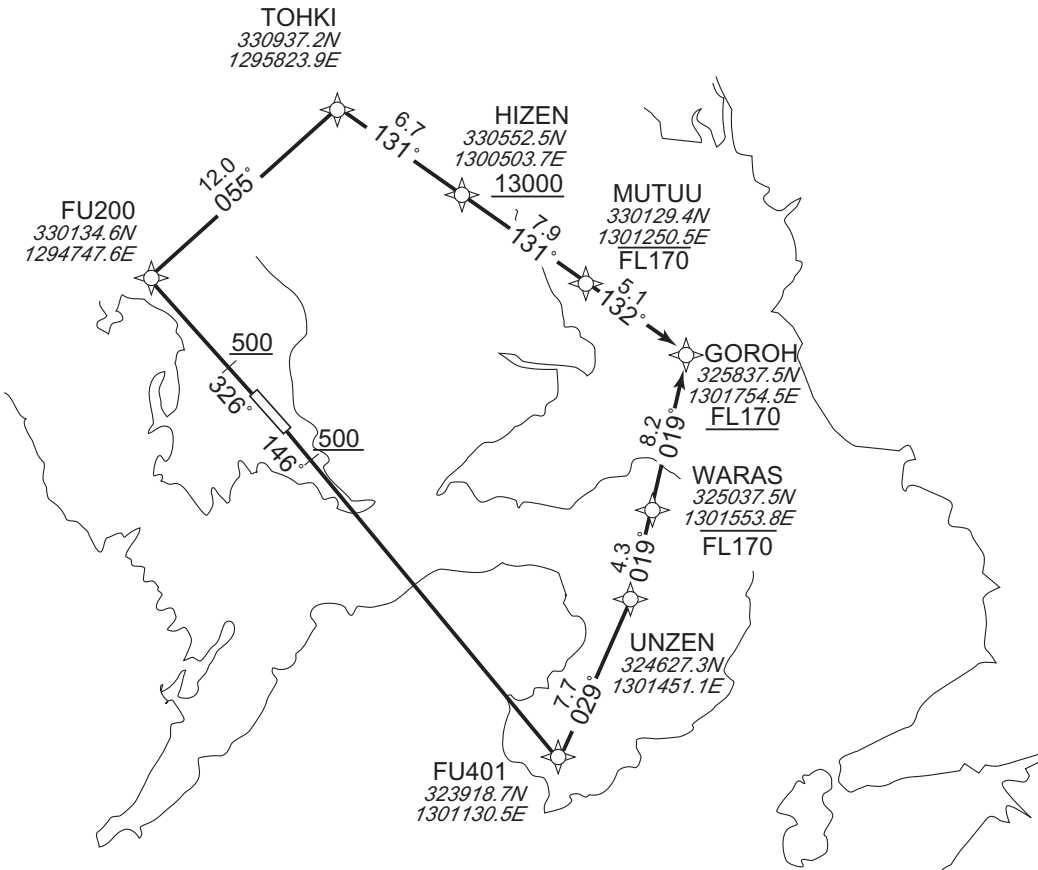

CHANGE : Navigation Specification(Basic RNP1 → RNP1).

RWY14 : Climb on HDG146° at or above 500FT, direct to FU401, to UNZEN, to WARAS at or below FL170, to GOROH at or above FL170.

RWY32 : Climb on HDG326° at or above 500FT, direct to FU200, to TOHKI, to HIZEN at or above 13000FT, to MUTUU at or below FL170, to GOROH at or above FL170.

NOTE RWY14 : 5.0% climb gradient required up to 4700FT.
OBST ALT 4954FT located at 20.8NM 122° FM end of RWY14.
RWY32 : 5.0% climb gradient required up to 500FT.
OBST ALT 2067FT located at 9.8NM 013° FM end of RWY32.

STANDARD DEPARTURE CHART -INSTRUMENT

RJFU / NAGASAKI

RNAV SID

CHIKUGO FIVE DEPARTURE

RWY14

Serial Number	Path Descriptor	Waypoint Identifier	Fly Over	Course °M(°T)	Magnetic Variation	Distance (NM)	Turn Direction	Altitude (FT)	Speed (KIAS)	Vertical Angle	Navigation Specification
001	VA	-	-	146 (138.1)	-7.6	-	-	+500	-	-	RNP1
002	DF	FU401	-	-	-7.6	-	-	-	-	-	RNP1
003	TF	UNZEN	-	029 (021.5)	-7.6	7.7	-	-	-	-	RNP1
004	TF	WARAS	-	019 (011.9)	-7.6	4.3	-	-FL170	-	-	RNP1
005	TF	GOROH	-	019 (011.9)	-7.6	8.2	-	+FL170	-	-	RNP1

RWY32

Serial Number	Path Descriptor	Waypoint Identifier	Fly Over	Course °M(°T)	Magnetic Variation	Distance (NM)	Turn Direction	Altitude (FT)	Speed (KIAS)	Vertical Angle	Navigation Specification
001	VA	-	-	326 (318.1)	-7.6	-	-	+500	-	-	RNP1
002	DF	FU200	-	-	-7.6	-	-	-	-	-	RNP1
003	TF	TOHKI	-	055 (047.8)	-7.6	12.0	-	-	-	-	RNP1
004	TF	HIZEN	-	131 (123.8)	-7.6	6.7	-	+13000	-	-	RNP1
005	TF	MUTUU	-	131 (123.9)	-7.6	7.9	-	-FL170	-	-	RNP1
006	TF	GOROH	-	132 (124.0)	-7.6	5.1	-	+FL170	-	-	RNP1

CHANGE : Navigation Specification(Basic RNP1 → RNP1).

STANDARD DEPARTURE CHART -INSTRUMENT

RJFU / NAGASAKI RNAV TRANSITION

SALTY TRANSITION / OOITA TRANSITION

RNP1

Note GNSS required.

VAR 8° W

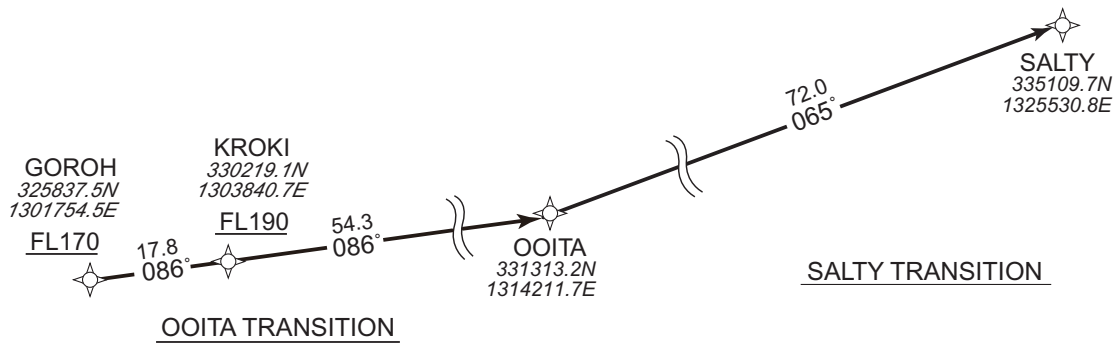

SALTY TRANSITION

From GOROH at or above FL170, to KROKI at or above FL190, to OOITA, to SALTY.

Serial Number	Path Descriptor	Waypoint Identifier	Fly Over	Course °M(°T)	Magnetic Variation	Distance (NM)	Turn Direction	Altitude (FT)	Speed (KIAS)	Vertical Angle	Navigation Specification
001	IF	GOROH	-	-	-7.6	-	-	+FL170	-	-	RNP1
002	TF	KROKI	-	086 (077.9)	-7.6	17.8	-	+FL190	-	-	RNP1
003	TF	OOITA	-	086 (078.1)	-7.6	54.3	-	-	-	-	RNP1
004	TF	SALTY	-	065 (057.8)	-7.6	72.0	-	-	-	-	RNP1

OOITA TRANSITION

From GOROH at or above FL170, to KROKI at or above FL190, to OOITA.

Serial Number	Path Descriptor	Waypoint Identifier	Fly Over	Course °M(°T)	Magnetic Variation	Distance (NM)	Turn Direction	Altitude (FT)	Speed (KIAS)	Vertical Angle	Navigation Specification
001	IF	GOROH	-	-	-7.6	-	-	+FL170	-	-	RNP1
002	TF	KROKI	-	086 (077.9)	-7.6	17.8	-	+FL190	-	-	RNP1
003	TF	OOITA	-	086 (078.1)	-7.6	54.3	-	-	-	-	RNP1

CHANGE : Navigation Specification(Basic RNP1 → RNP1).

STANDARD DEPARTURE CHART -INSTRUMENT

RJFU / NAGASAKI

RNAV SID

KAZSA ONE DEPARTURE	RNP1
---------------------	------

Note GNSS required.

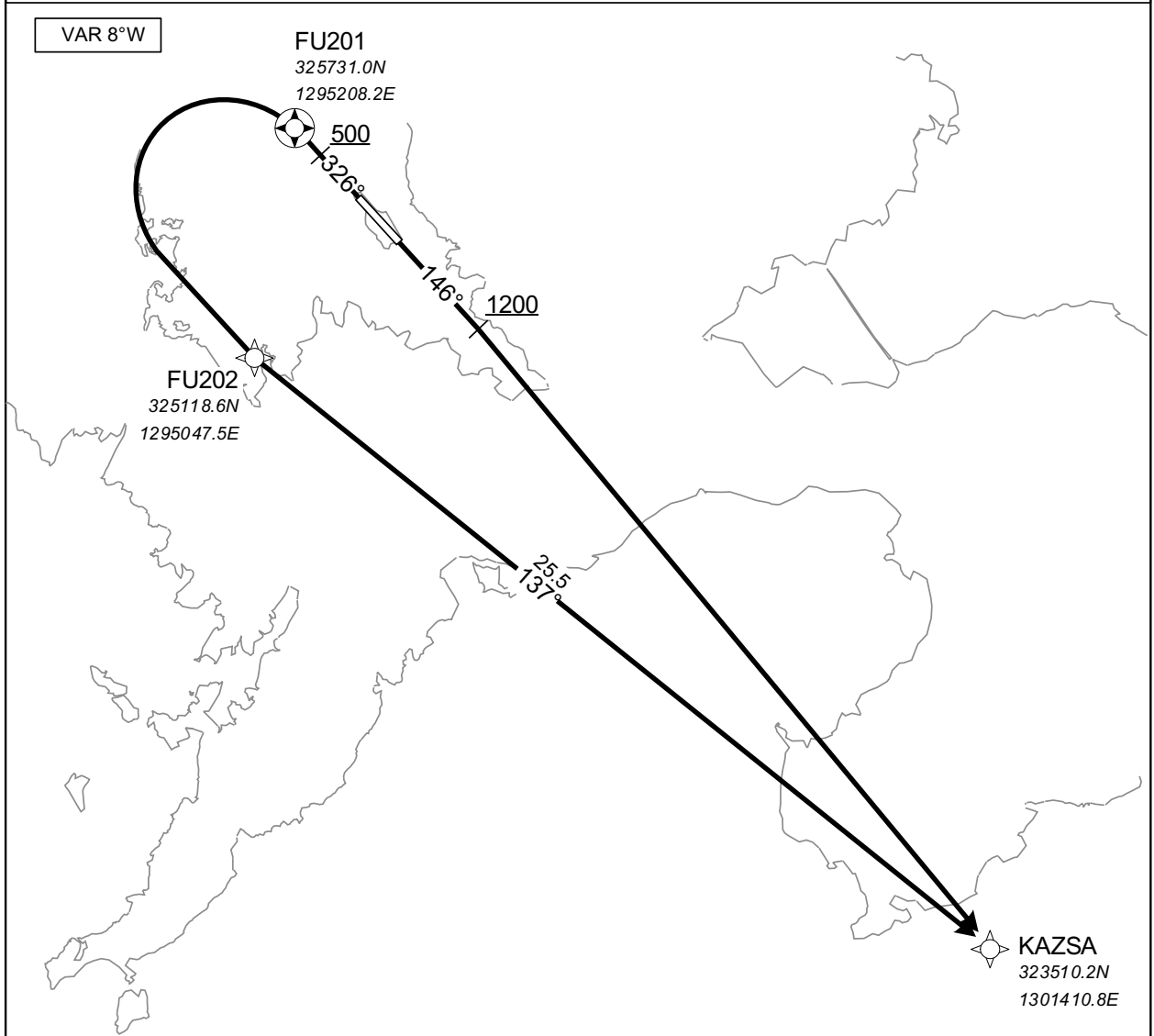

CHANGE : Navigation Specification(Basic RNP1 → RNP1).

RWY14 : Climb on HDG146° at or above 1200FT, direct to KAZSA

RWY32 : Climb on HDG326° at or above 500FT, direct to FU201, turn left direct to FU202, to KAZSA.

Note RWY14 : 5.0% climb gradient required up to 1200FT.

OBST ALT 892FT located at 4.1NM 130° FM end of RWY14.

OBST ALT 1050FT located at 4.6NM 165° FM end of RWY14.

RWY32 : 5.0% climb gradient required up to 1900FT.

OBST ALT 1936FT located at 8.0NM 272° FM end of RWY32.

STANDARD DEPARTURE CHART -INSTRUMENT

RJFU / NAGASAKI

RNAV SID

KAZSA ONE DEPARTURE

RWY14

Serial Number	Path Descriptor	Waypoint Identifier	Fly Over	Course °M(°T)	Magnetic Variation	Distance (NM)	Turn Direction	Altitude (FT)	Speed (KIAS)	Vertical Angle	Navigation Specification
001	VA	-	-	146 (138.1)	-7.6	-	-	+1200	-	-	RNP1
002	DF	KAZSA	-	-	-7.6	-	-	-	-	-	RNP1

RWY32

Serial Number	Path Descriptor	Waypoint Identifier	Fly Over	Course °M(°T)	Magnetic Variation	Distance (NM)	Turn Direction	Altitude (FT)	Speed (KIAS)	Vertical Angle	Navigation Specification
001	VA	-	-	326 (318.1)	-7.6	-	-	+500	-	-	RNP1
002	DF	FU201	Y	-	-7.6	-	-	-	-	-	RNP1
003	DF	FU202	-	-	-7.6	-	L	-	-	-	RNP1
004	TF	KAZSA	-	137 (129.3)	-7.6	25.5	-	-	-	-	RNP1

CHANGE : Navigation Specification(Basic RNP1 → RNP1).

STANDARD DEPARTURE CHART -INSTRUMENT

RJFU / NAGASAKI

RNAV SID

AKNAG ONE DEPARTURE	RNP1
----------------------------	-------------

Note GNSS required.

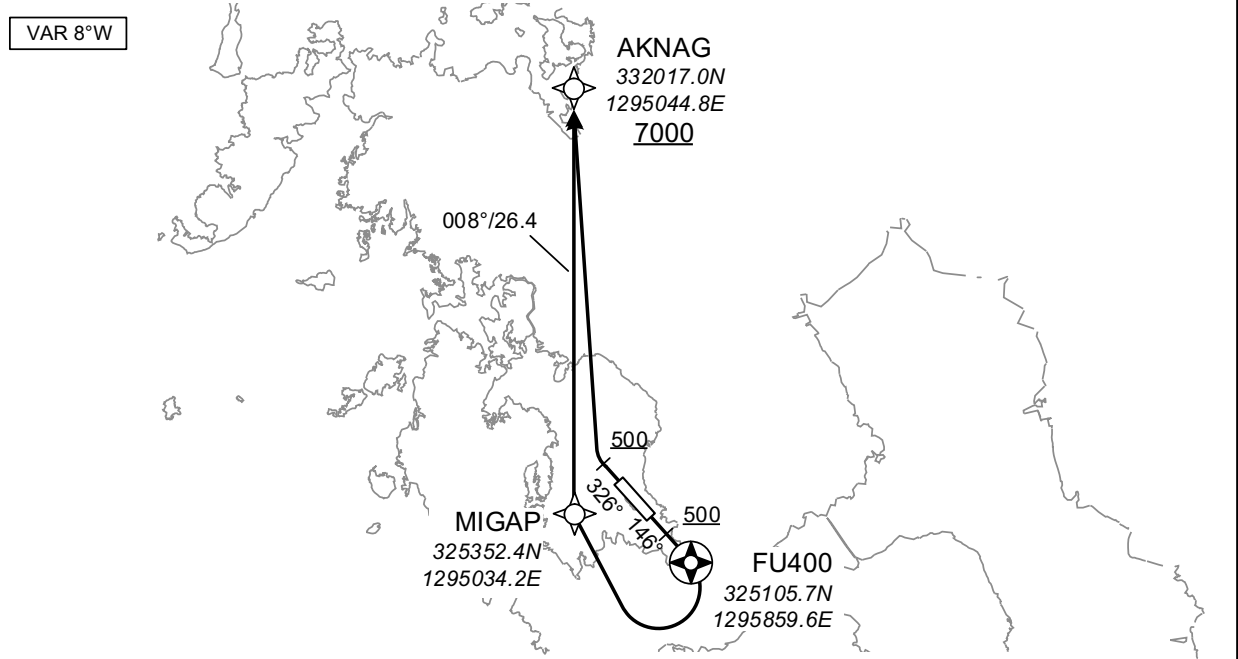

RWY14 : Climb on HDG146° at or above 500FT, direct to FU400, turn right direct to MIGAP, to AKNAG at or above 7000FT.

RWY32 : Climb on HDG326° at or above 500FT, turn right direct to AKNAG at or above 7000FT.

Note RWY14 : 5.0% climb gradient required up to 1800FT.

OBST ALT 1247FT located at 4.2NM 177° FM end of RWY14.

OBST ALT 1634FT located at 3.6NM 211° FM end of RWY14.

RWY32 : 5.0% climb gradient required up to 1200FT.

OBST ALT 1739FT located at 8.7NM 010° FM end of RWY32.

CHANGE : Navigation Specification(Basic RNP1 → RNP1).

RWY14

Serial Number	Path Descriptor	Waypoint Identifier	Fly Over	Course °M(°T)	Magnetic Variation	Distance (NM)	Turn Direction	Altitude (FT)	Speed (KIAS)	Vertical Angle	Navigation Specification
001	VA	-	-	146 (138.1)	-7.7	-	-	+500	-	-	RNP1
002	DF	FU400	Y	-	-7.7	-	-	-	-	-	RNP1
003	DF	MIGAP	-	-	-7.7	-	R	-	-	-	RNP1
004	TF	AKNAG	-	008 (000.3)	-7.7	26.4	-	+7000	-	-	RNP1

RWY32

Serial Number	Path Descriptor	Waypoint Identifier	Fly Over	Course °M(°T)	Magnetic Variation	Distance (NM)	Turn Direction	Altitude (FT)	Speed (KIAS)	Vertical Angle	Navigation Specification
001	VA	-	-	326 (318.1)	-7.7	-	-	+500	-	-	RNP1
002	DF	AKNAG	-	-	-7.7	-	R	+7000	-	-	RNP1

STANDARD DEPARTURE CHART -INSTRUMENT

RJFU / NAGASAKI

RNAV SID

CARCO ONE DEPARTURE

RNP1

Note GNSS required.

VAR 8°W

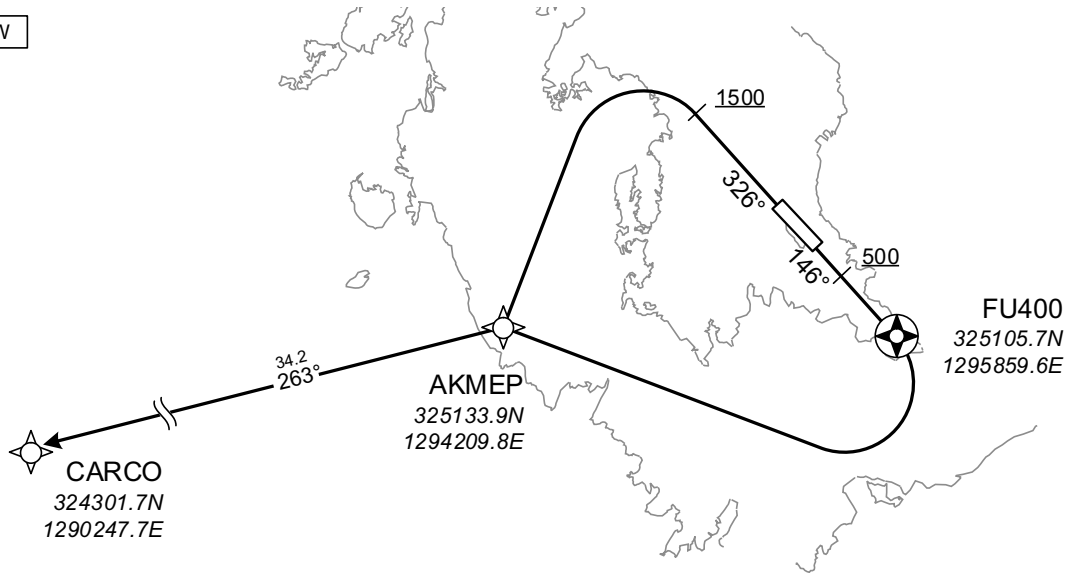

RWY14 : Climb on HDG146° at or above 500FT, direct to FU400, turn right direct to AKMEP, to CARCO.

RWY32 : Climb on HDG326° at or above 1500FT, turn left direct to AKMEP, to CARCO.

Note RWY14 : 5.0% climb gradient required up to 1800FT.

OBST ALT 1247FT located at 4.2NM 177° FM end of RWY14.

OBST ALT 1634FT located at 3.6NM 211° FM end of RWY14.

RWY32 : 5.0% climb gradient required up to 1500FT.

OBST ALT 1969FT located at 8.0NM 272° FM end of RWY32.

RWY14

Serial Number	Path Descriptor	Waypoint Identifier	Fly Over	Course °M(°T)	Magnetic Variation	Distance (NM)	Turn Direction	Altitude (FT)	Speed (KIAS)	Vertical Angle	Navigation Specification
001	VA	-	-	146 (138.1)	-7.7	-	-	+500	-	-	RNP1
002	DF	FU400	Y	-	-7.7	-	-	-	-	-	RNP1
003	DF	AKMEP	-	-	-7.7	-	R	-	-	-	RNP1
004	TF	CARCO	-	263 (255.7)	-7.7	34.2	-	-	-	-	RNP1

RWY32

Serial Number	Path Descriptor	Waypoint Identifier	Fly Over	Course °M(°T)	Magnetic Variation	Distance (NM)	Turn Direction	Altitude (FT)	Speed (KIAS)	Vertical Angle	Navigation Specification
001	VA	-	-	326 (318.1)	-7.7	-	-	+1500	-	-	RNP1
002	DF	AKMEP	-	-	-7.7	-	L	-	-	-	RNP1
003	TF	CARCO	-	263 (255.7)	-7.7	34.2	-	-	-	-	RNP1

CHANGE : Navigation Specification(Basic RNP1 → RNP1).

STANDARD ARRIVAL CHART-INSTRUMENT

RJFU / NAGASAKI

RNAV STAR

SARUKU ARRIVAL / FUBUKI ARRIVAL

RNP1

Note GNSS required.

VAR 8° W

CHANGE : Navigation Specification(Basic RNP1 → RNP1).

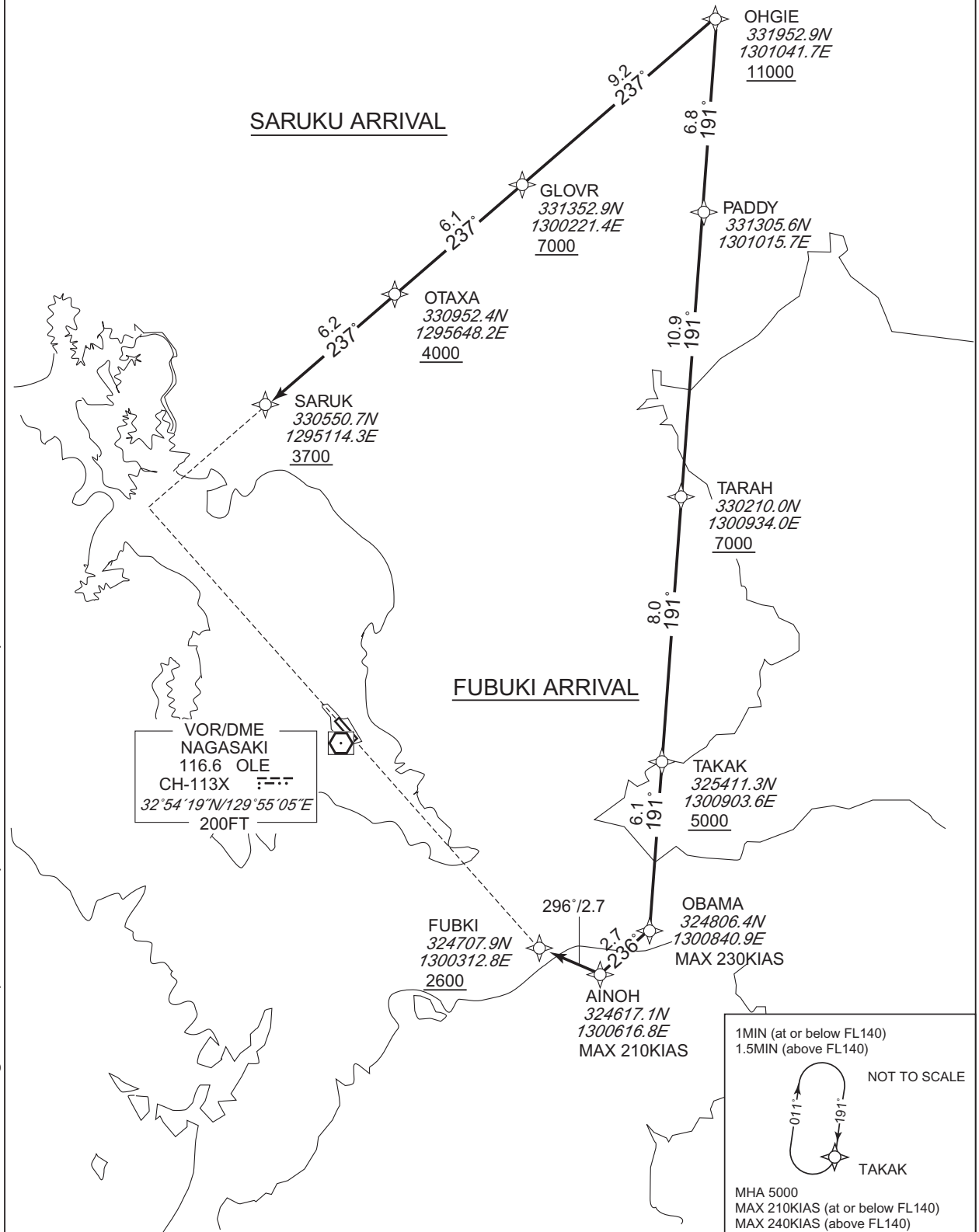

1MIN (at or below FL140)
1.5MIN (above FL140)

NOT TO SCALE

TAKAK

MHA 5000
MAX 210KIAS (at or below FL140)
MAX 240KIAS (above FL140)

STANDARD ARRIVAL CHART-INSTRUMENT

RJFU / NAGASAKI

RNAV STAR

SARUKU ARRIVAL

From OHGIE at or above 11000FT, to GLOVR at or above 7000FT, to OTAXA at or above 4000FT, to SARUK at or above 3700FT.

Serial Number	Path Descriptor	Waypoint Identifier	Fly Over	Course °M(°T)	Magnetic Variation	Distance (NM)	Turn Direction	Altitude (FT)	Speed (KIAS)	Vertical Angle	Navigation Specification
001	IF	OHGIE	-	-	-7.6	-	-	+11000	-	-	RNP1
002	TF	GLOVR	-	237 (229.3)	-7.6	9.2	-	+7000	-	-	RNP1
003	TF	OTAXA	-	237 (229.2)	-7.6	6.1	-	+4000	-	-	RNP1
004	TF	SARUK	-	237 (229.2)	-7.6	6.2	-	+3700	-	-	RNP1

FUBUKI ARRIVAL

From OHGIE at or above 11000FT, to PADDY, to TARAH at or above 7000FT, to TAKAK at or above 5000FT, to OBAMA, to AINOH, to FUBKI at or above 2600FT.

Serial Number	Path Descriptor	Waypoint Identifier	Fly Over	Course °M(°T)	Magnetic Variation	Distance (NM)	Turn Direction	Altitude (FT)	Speed (KIAS)	Vertical Angle	Navigation Specification
001	IF	OHGIE	-	-	-7.6	-	-	+11000	-	-	RNP1
002	TF	PADDY	-	191 (183.1)	-7.6	6.8	-	-	-	-	RNP1
003	TF	TARAH	-	191 (183.1)	-7.6	10.9	-	+7000	-	-	RNP1
004	TF	TAKAK	-	191 (183.0)	-7.6	8.0	-	+5000	-	-	RNP1
005	TF	OBAMA	-	191 (183.0)	-7.6	6.1	-	-	-230	-	RNP1
006	TF	AINOH	-	236 (228.0)	-7.6	2.7	-	-	-210	-	RNP1
007	TF	FUBKI	-	296 (288.2)	-7.6	2.7	-	+2600	-	-	RNP1

Path	Waypoint Identifier	Inbound Course °M(°T)	Magnetic Variation	Outbound Time (MIN)	Turn Direction	Minimum Altitude (FT)	Maximum Altitude (FT)	Speed (KIAS)	Navigation Specification
Hold	TAKAK	191 (183.0)	-7.6	1.0(-14000) 1.5(+14001)	R	5000	-	-210(-14000) -240(+14001)	RNP1

CHANGE : Navigation Specification(Basic RNP1 → RNP1).

INSTRUMENT APPROACH CHART

RJFU / NAGASAKI

ILS Z or LOC Z RWY32

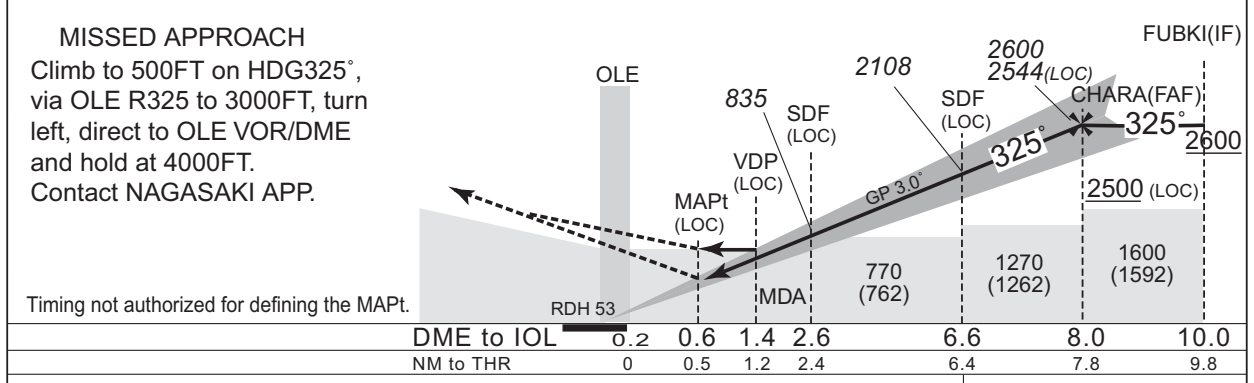
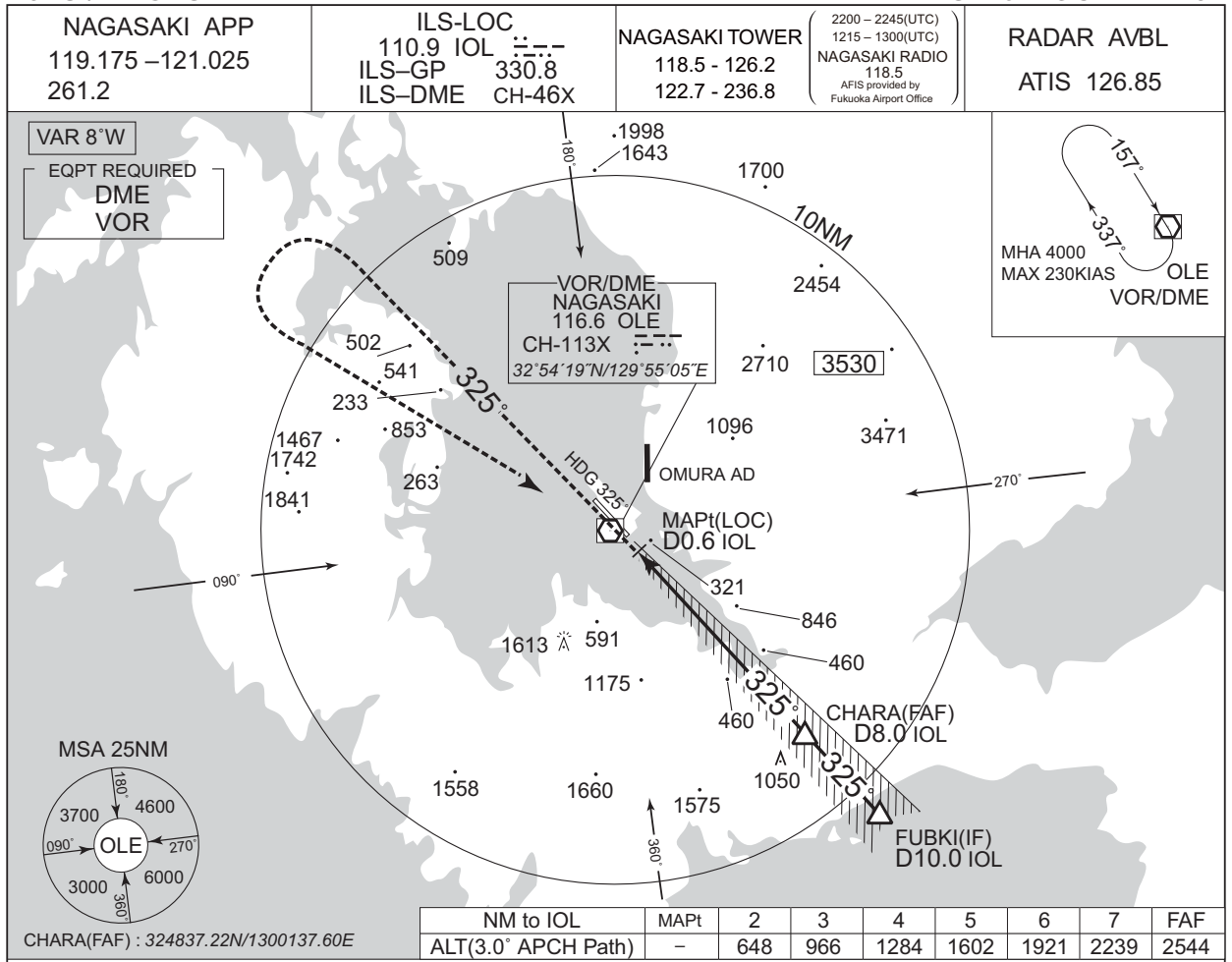

MINIMA		THR elev. 15		AD elev. 8		
CAT	CAT I		LOC		CIRCLING	
	DA(H)	RVR/CMV	MDA(H)	RVR/CMV	MDA(H)	VIS
A	215 (200)	550	430 (422)	900	620 (612)	1600
B				1000		
C				2400		
D				1400		

CHANGE : Description of VAR.

INSTRUMENT APPROACH CHART

RJFU / NAGASAKI

ILS Y or LOC Y RWY32

<p>NAGASAKI APP 119.175 - 121.025 261.2</p>	<p>ILS-LOC 110.9 IOL ILS-GP 330.8 ILS-DME CH-46X</p>	<p>NAGASAKI TOWER 118.5 - 126.2 122.7 - 236.8</p> <p>(2200 - 2245(UTC) 1215 - 1300(UTC) NAGASAKI RADIO 118.5 AFIS provided by Fukuoka Airport Office)</p>	<p>RADAR AVBL ATIS 126.85</p>
---	--	---	-----------------------------------

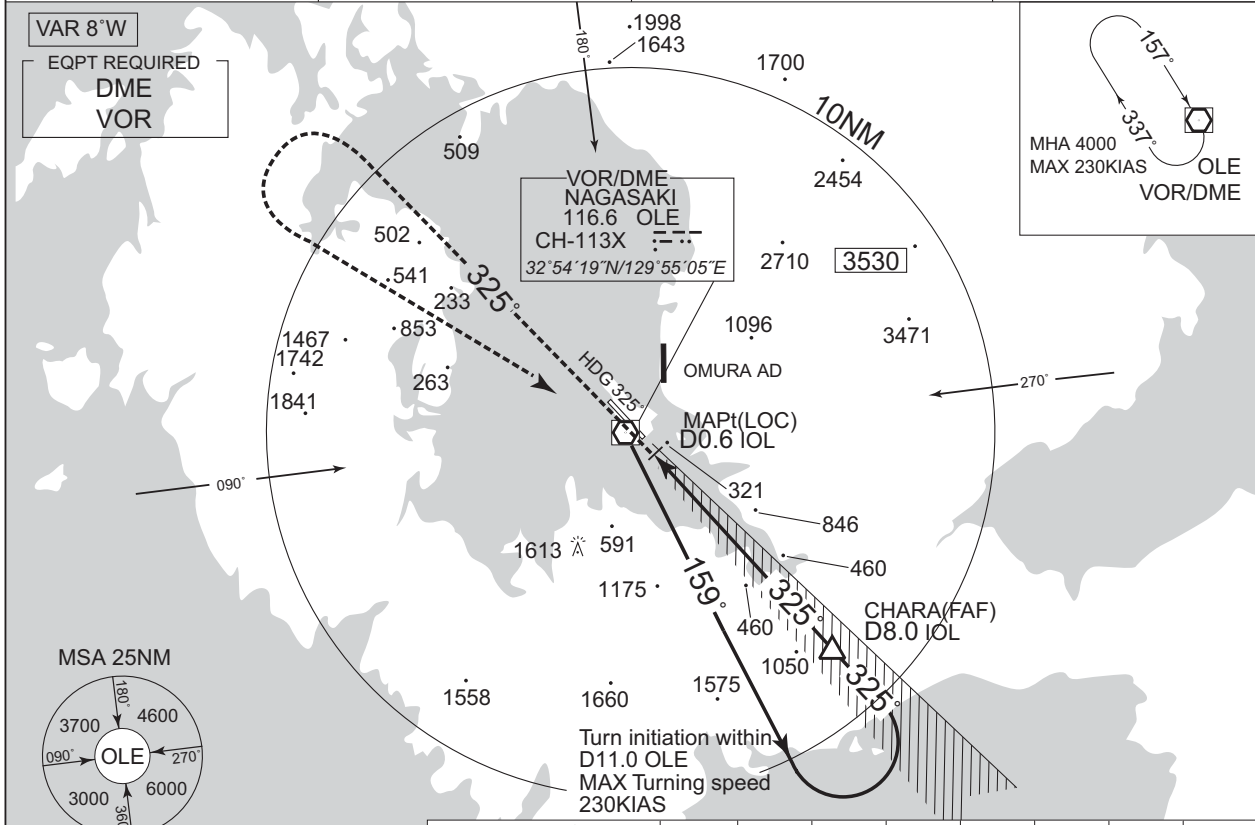

NM to IOL	MAPt	2	3	4	5	6	7	FAF
ALT(3.0° APCH Path)	-	648	966	1284	1602	1921	2239	2544

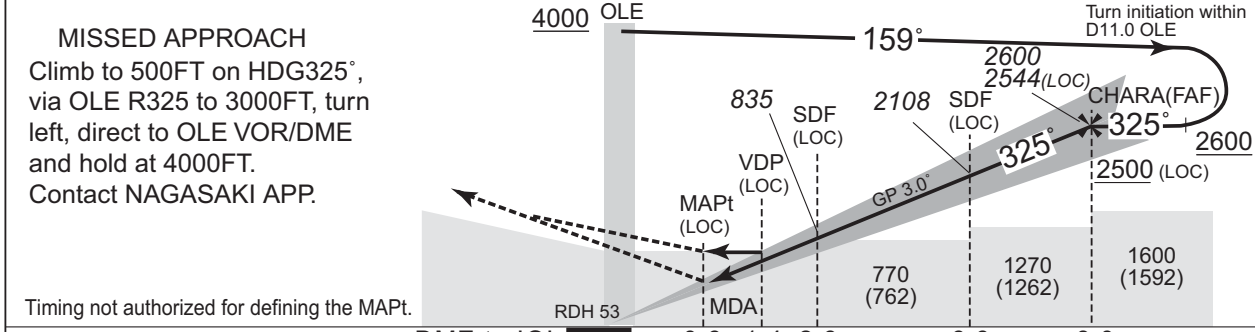

DME to IOL	0.2	0.6	1.4	2.6	6.6	8.0
NM to THR	0	0.5	1.2	2.4	6.4	7.8

MINIMA		THR elev. 15		AD elev. 8			
CAT	CAT I		LOC		CIRCLING		
	DA(H)	RVR/CMV	MDA(H)	RVR/CMV	MDA(H)	VIS	
A	215 (200)	550	430 (422)	900	620 (612)	1600	
B				1000			
C				1400			2400
D				890 (882)			3200

CHANGE : Description of VAR.

INSTRUMENT APPROACH CHART

RJFU / NAGASAKI

RNP RWY32

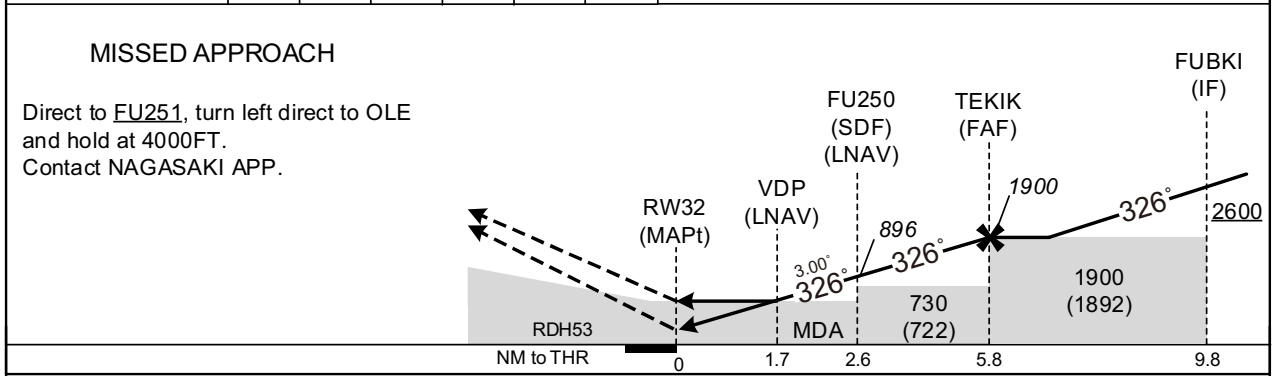
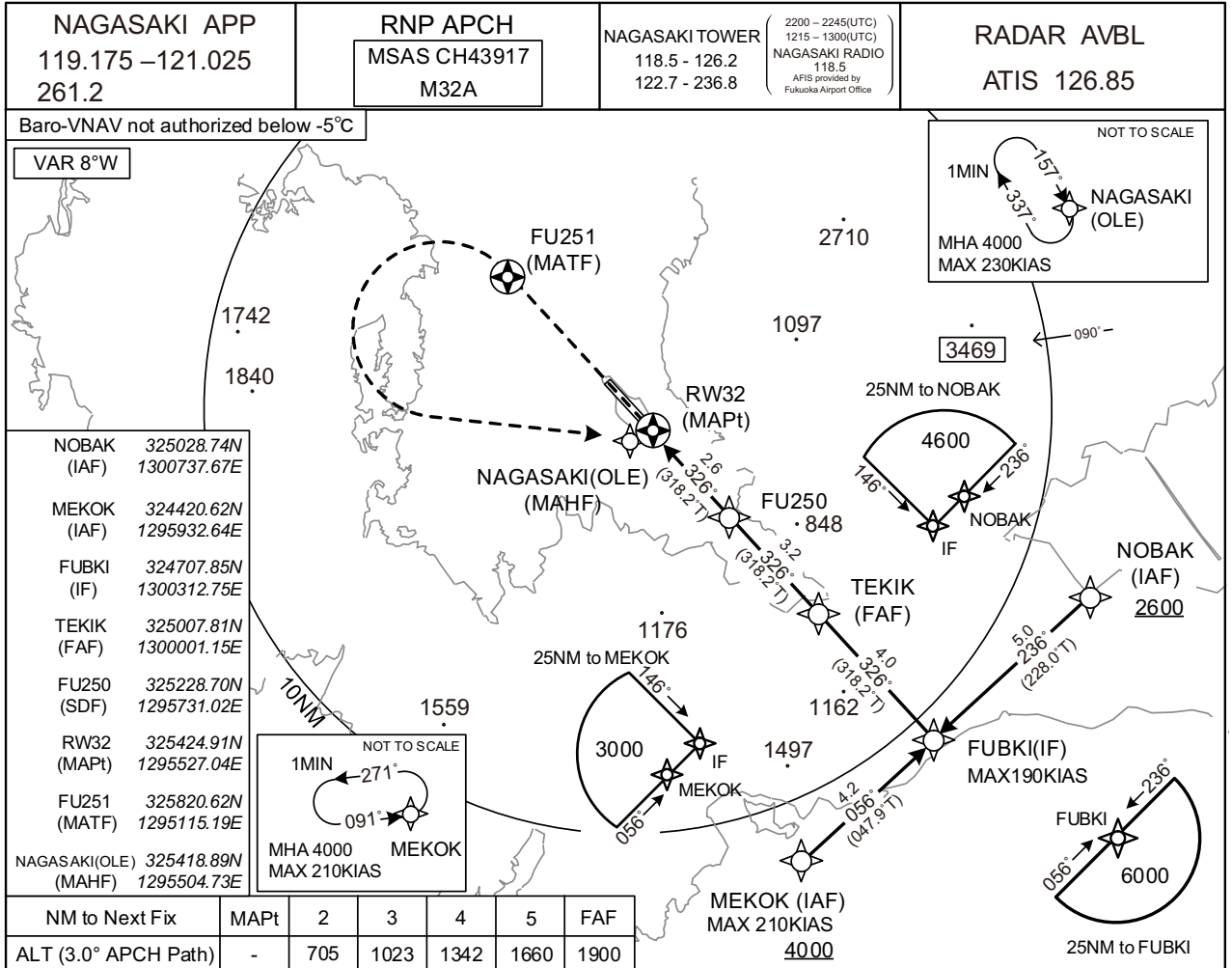

Missed APCH climb gradient MNM 5.0%

CAT	MINIMA		THR elev. 15		AD elev. 8		CIRCLING	
	LPV	RVR/CMV	LNAV/VNAV	LNAV	LNAV	RVR/CMV	MDA(H)	VIS
A	288(273)	800	580(565)	1000	580(572)	1000	620(612)	1600
B	297(282)			1200		1200		
C	307(292)			1600		1600		
D	317(302)	1400				890(882)	3200	

MINIMA with Missed APCH climb gradient of 2.5% are not established.

CHANGE : Description of VAR.

INSTRUMENT APPROACH CHART

RJFU / NAGASAKI

RNP RWY32

FAS DATA BLOCK

Operation type	0	LTP/FTP ellipsoidal height	+00370
SBAS service provider identifier	2	FPAP latitude	325537.2480N
Airport identifier	RJFU	FPAP longitude	1295409.7775E
Runway	32	Threshold crossing height	00016.2
Approach performance designator	0	TCH units selector	1
Route indicator		Glide path angle	03.00
Reference path data selector	0	Course width at threshold	105.00
Reference path ID	M32A	∠ length offset	0000
LTP/FTP latitude	325424.8850N	HAL	40.0
LTP/FTP longitude	1295527.0410E	VAL	50.0
CRC remainder	10898D02		

Required additional data

LTP/FTP orthometric height	4.8
----------------------------	-----

CHANGE : Description of FAS DATA BLOCK ITEM(CRC remainder).

INSTRUMENT APPROACH CHART

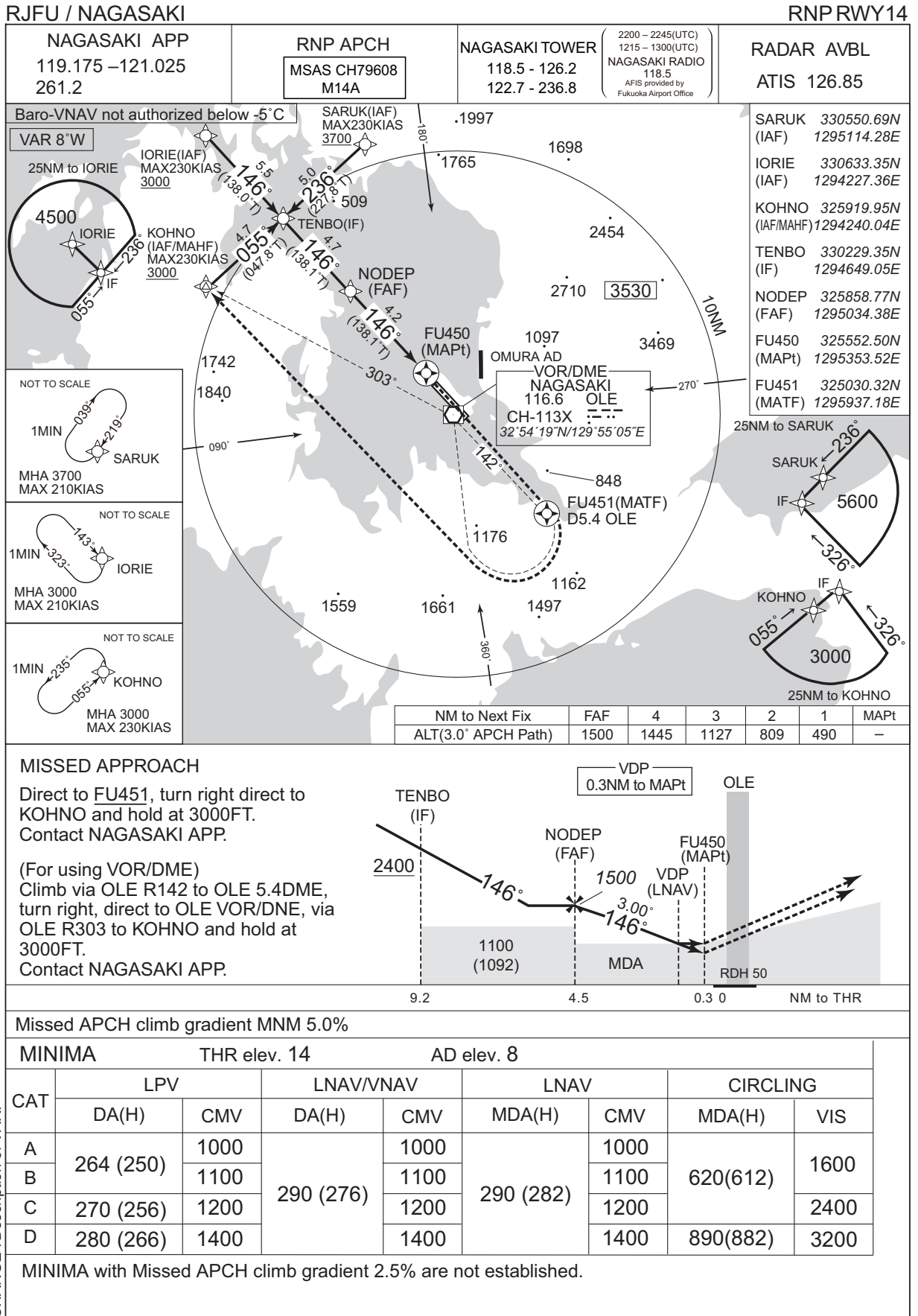

INSTRUMENT APPROACH CHART

RJFU / NAGASAKI

RNP RWY14

FAS DATA BLOCK

Operation type	0	LTP/FTP ellipsoidal height	+00367
SBAS service provider identifier	2	FPAP latitude	325424.8850N
Airport identifier	RJFU	FPAP longitude	1295527.0410E
Runway	14	Threshold crossing height	00015.0
Approach performance designator	0	TCH units selector	1
Route indicator		Glide path angle	03.00
Reference path data selector	0	Course width at threshold	105.00
Reference path ID	M14A	∠ length offset	0000
LTP/FTP latitude	325537.2480N	HAL	40.0
LTP/FTP longitude	1295409.7775E	VAL	50.0
CRC remainder	B756639A		

Required additional data

LTP/FTP orthometric height	4.5
----------------------------	-----

CHANGE : Description of FAS DATA BLOCK ITEM(CRC remainder).

INSTRUMENT APPROACH CHART

RJFU / NAGASAKI

VOR RWY32

<p>NAGASAKI APP 119.175 - 121.025 261.2</p>	<p>NAGASAKI VOR/DME 116.6 OLE $\cdot\cdot\cdot\cdot$ CH-113X 32°54'19"N/129°55'05"E</p>	<p>NAGASAKI TOWER 118.5 - 126.2 122.7 - 236.8</p> <p>2200 - 2245(UTC) 1215 - 1300(UTC) NAGASAKI RADIO 118.5 AFIS provided by Fukuoka Airport Office</p>	<p>RADAR AVBL ATIS 126.85</p>
---	--	---	-----------------------------------



<p>INASA(FAF) : 325055.82N/1300058.17E</p>	<p>NM to OLE</p>	<p>MAPt</p>	<p>2</p>	<p>3</p>	<p>4</p>	<p>5</p>	<p>FAF</p>
<p>ALT (3.3° APCH Path)</p>	<p>-</p>	<p>697</p>	<p>1047</p>	<p>1397</p>	<p>1748</p>	<p>2098</p>	<p></p>

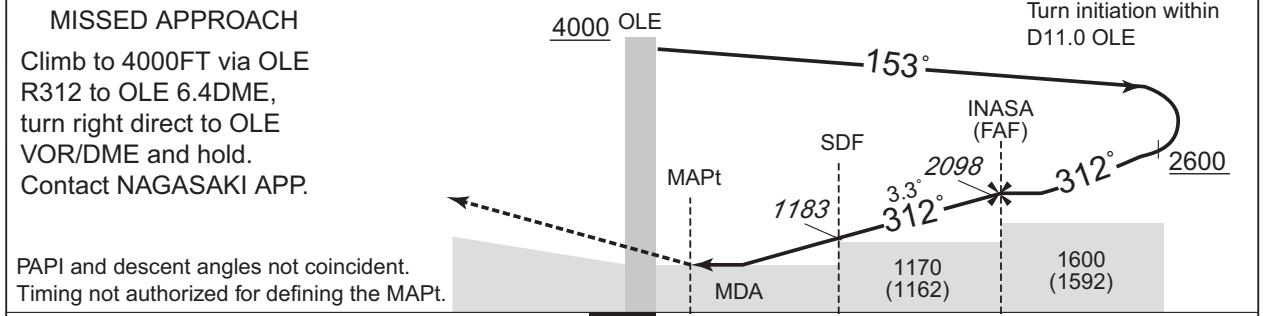

<p>DME to OLE</p>	<p>0.3</p>	<p>1.0</p>	<p>3.4</p>	<p>6.0</p>
<p>NM to THR</p>	<p>0</p>	<p>0.8</p>	<p>3.2</p>	<p>5.8</p>

MINIMA		THR elev. 15		AD elev. 8	
CAT	MDA(H)	RVR/CMV	CIRCLING		
A	570 (562)	1000	620 (612)	1600	
B		1200			
C			1600	890 (882)	3200
D					

CHANGE : Description of VAR.

INSTRUMENT APPROACH CHART

RJFU / NAGASAKI

VOR RWY14

<p>NAGASAKI APP 119.175 - 121.025 261.2</p>	<p>NAGASAKI VOR/DME 116.6 OLE CH-113X 32°54'19"N/129°55'05"E</p>	<p>NAGASAKI TOWER 118.5 - 126.2 122.7 - 236.8</p> <p>2200 - 2245(UTC) 1215 - 1300(UTC) NAGASAKI RADIO 118.5 AFIS provided by Fukuoka Airport Office</p>	<p>RADAR AVBL ATIS 126.85</p>
---	--	---	-----------------------------------

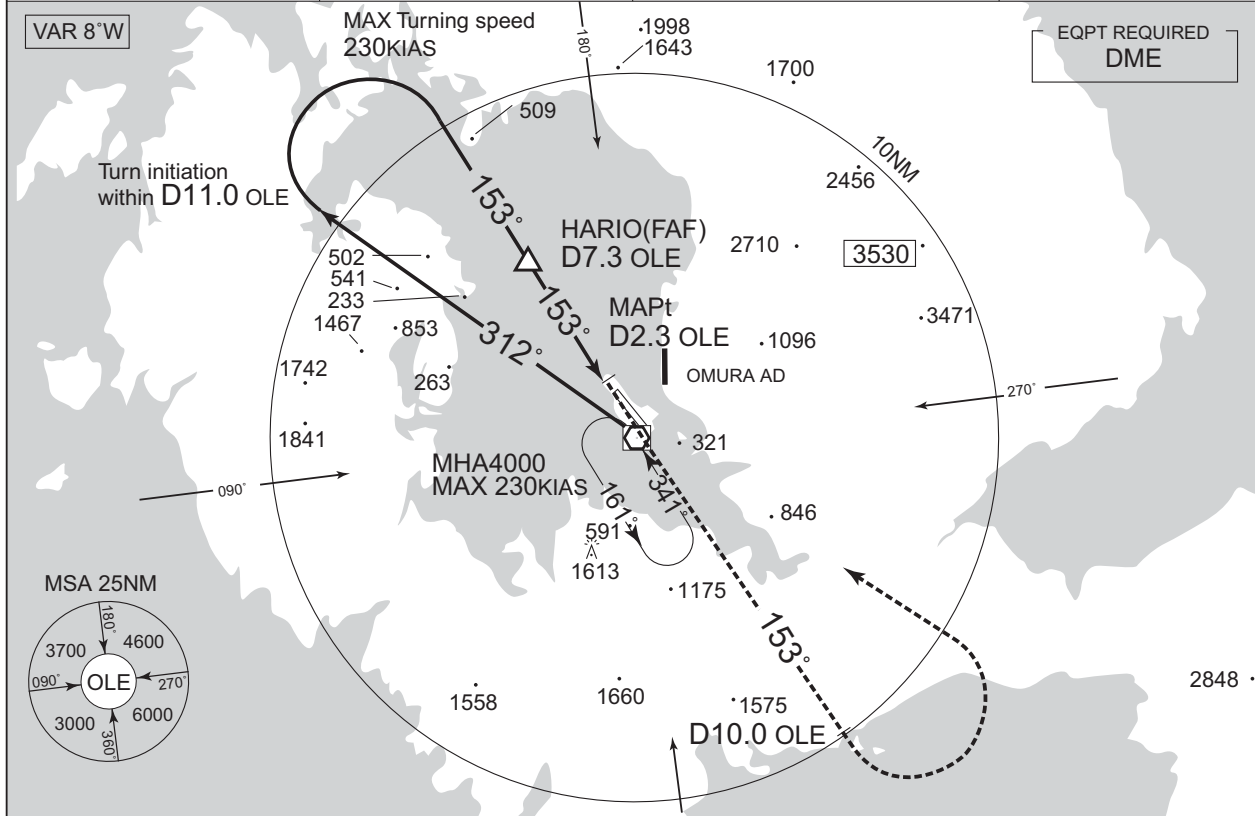

NM to OLE	FAF	7	6	5	4	3	MAPt
ALT (3.0° APCH Path)	1897	1814	1496	1178	859	541	-

HARIO(FAF) : 330019.11N/1295012.08E

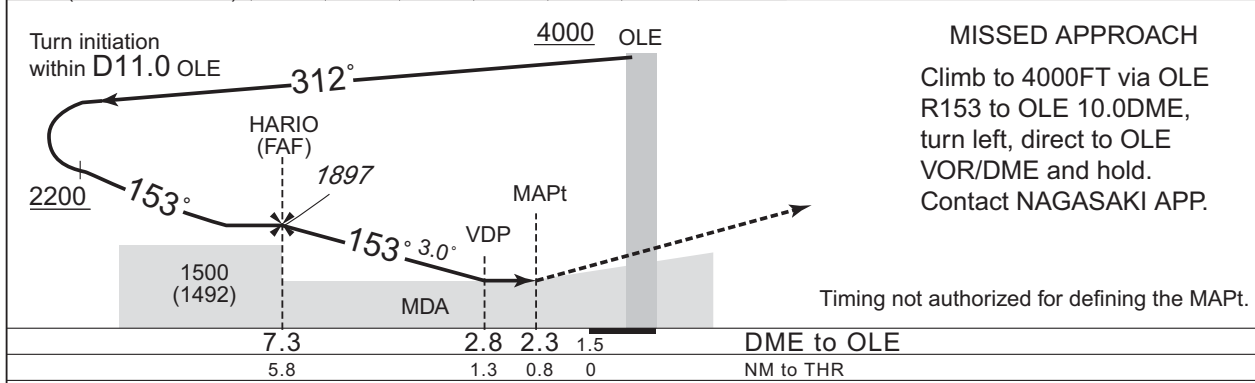

Missed APCH climb gradient MNM 3.0%

MINIMA		THR elev. 14		AD elev. 8	
CAT	MDA(H)		CIRCLING		VIS
	MDA(H)	CMV	MDA(H)	VIS	
A	490 (482)	1400	620 (612)	1600	
B		1500			
C		1600	2400		
D		1800	890 (882)	3200	

MINIMA with Missed APCH climb gradient 2.5% are not established.

CHANGE : Description of VAR.

RJFU / NAGASAKI

Visual REP



※図中に標高を示す数字がある場合、単位はメートル(m)である。The unit of measurement used to express elevation is meter(m).

CHANGE : Map updated. BRG/DIST from ARP.

Call sign	BRG / DIST from ARP	Remarks
川棚 Kawatana	345°T / 9.4NM	JR駅 JR Station
彼杵 Sonogi	360°T / 7.4NM	JR駅 JR Station
鈴田 Suzuta	113°T / 4.3NM	長崎自動車道と国道34号線の交点 Intersection
長田 Nagata	112°T / 9.4NM	不知火橋 Bridge
西彼 Seihi	301°T / 9.2NM	オランダ村 Windmill
二島 Futashima	244°T / 3.1NM	二島 Island
堂崎 Dozaki	217°T / 2.7NM	堂崎鼻 A point of land
鷹島 Takashima	237°T / 5.4NM	鷹島 Island
時津 Tokitsu	213°T / 6.0NM	時津港 Harbor
三重 Mie	233°T / 11.1NM	三重崎 A point of land

RJFU / NAGASAKI LDG CHART

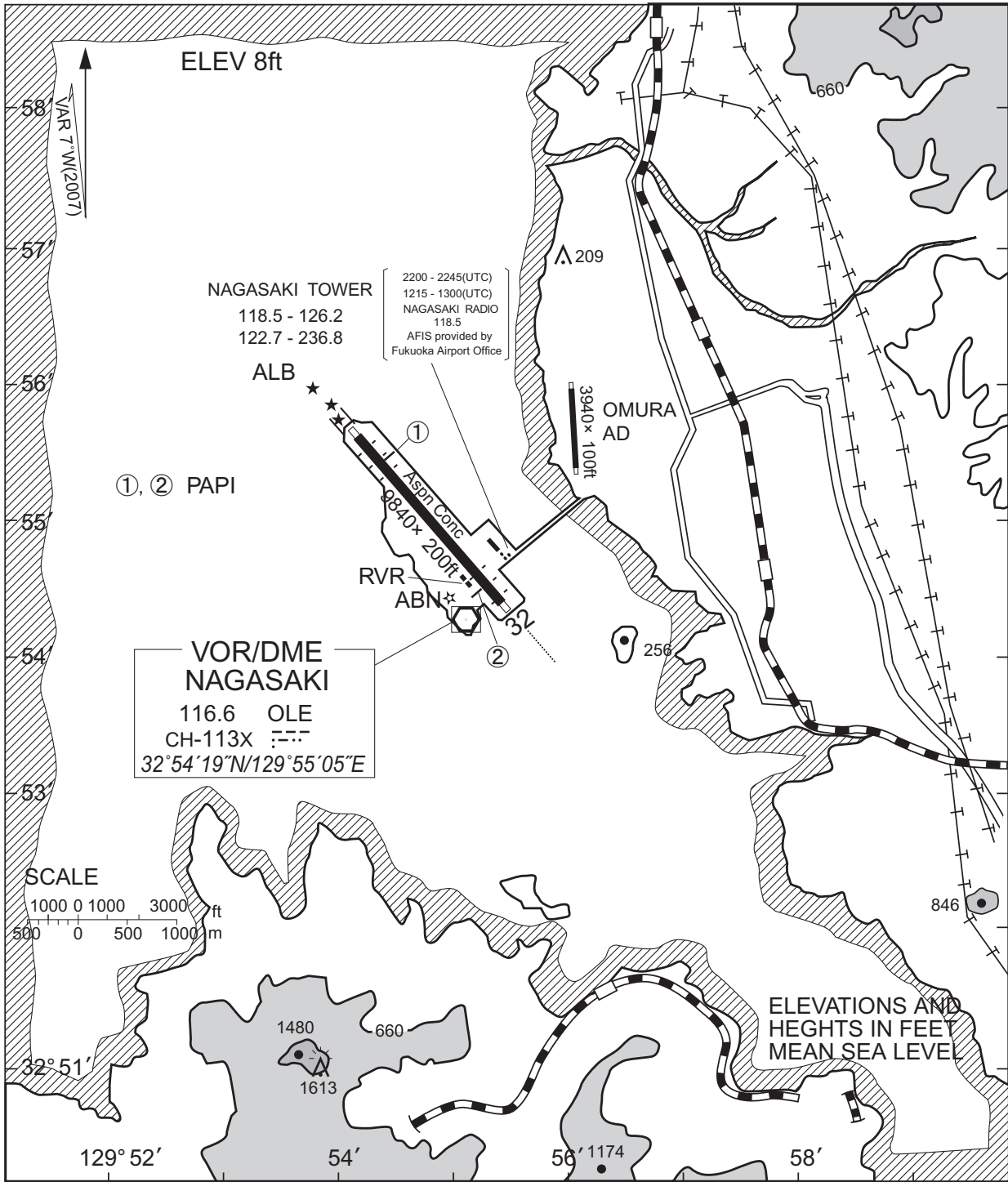

CHANGE : AFIS unit added.

1	2
PAPI Angle 3.0° MEHT 22.5m(74ft) 471m FM THR	PAPI Angle 3.0° MEHT 19.7m(65ft) 444m FM THR

RJFU / NAGASAKI

HOLDING PATTERN

CHANGE : HLDG course.

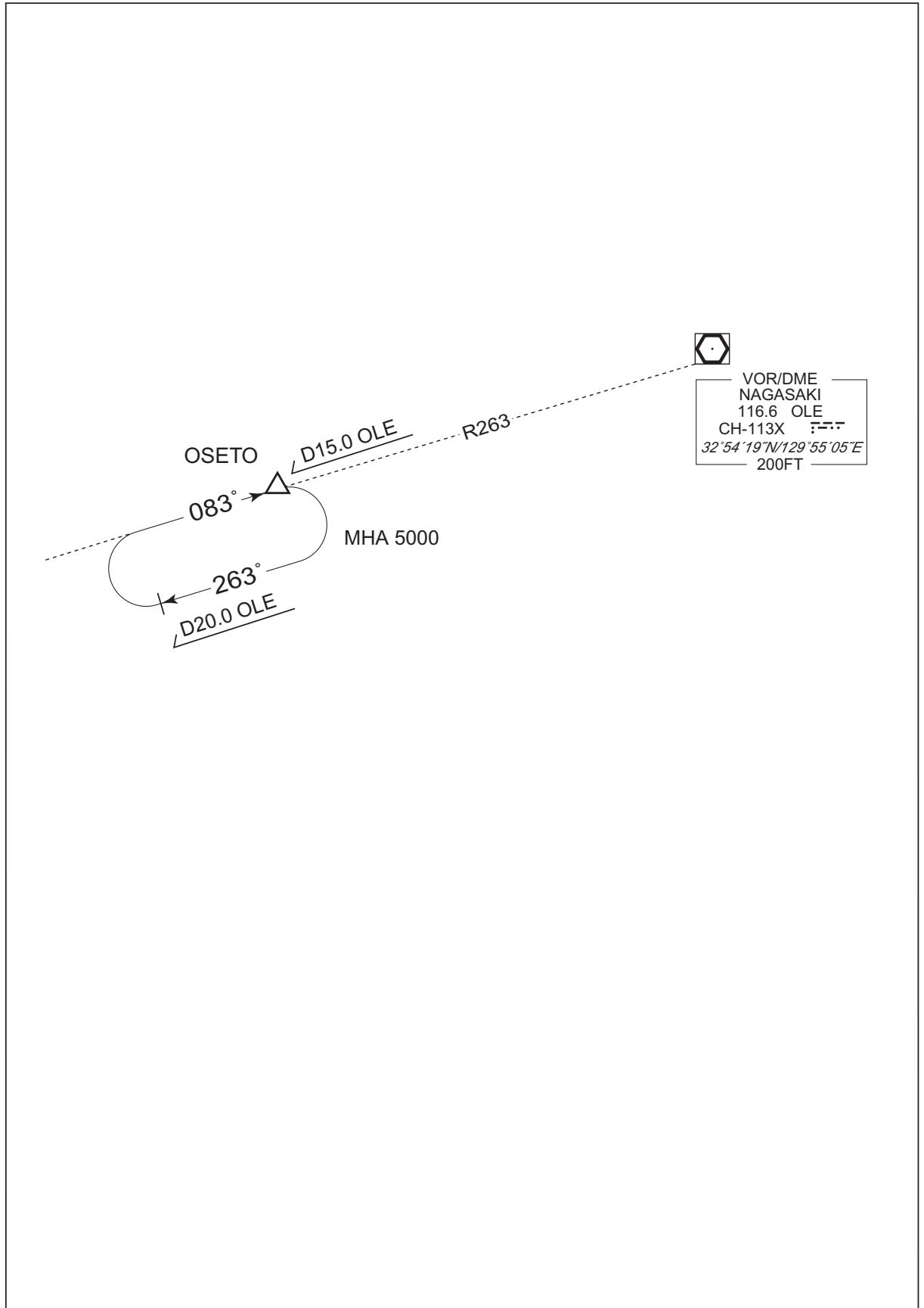

RJFU / NAGASAKI

Minimum Vectoring Altitude CHART

