

**AD 2 AERODROMES**

**RJFY AD 2.1 AERODROME LOCATION INDICATOR AND NAME**

**RJFY - KANOYA**

**RJFY AD 2.2 AERODROME GEOGRAPHICAL AND ADMINISTRATIVE DATA**

1	ARP coordinates and site at AD	312205N/1305017E
2	Direction and distance from (city)	1.5NM SW
3	Elevation/ Reference temperature	202ft / -
4	Geoid undulation at AD ELEV PSN	Nil
5	MAG VAR/ Annual change	Nil
6	AD Administration, address, telephone, telefax, telex, AFS, e-mail and/or Web-site addresses	JSDF-M
7	Types of traffic permitted (IFR/VFR)	IFR/VFR
8	Remarks	Headquarters Fleet Air Wing 1(FAW1) Tel: 0994-43-3111 ext.2208 or 2209

**RJFY AD 2.3 OPERATIONAL HOURS**

1	AD Administration	H24
2	Customs and immigration	Nil
3	Health and sanitation	Nil
4	AIS Briefing Office	H24
5	ATS Reporting Office(ARO)	Nil
6	MET Briefing Office	H24
7	ATS	H24
8	Fuelling	Nil
9	Handling	Nil
10	Security	Nil
11	De-icing	Nil
12	Remarks	24HR PPR for all flights

**RJFY AD 2.4 HANDLING SERVICES AND FACILITIES**

1	Cargo-handling facilities	Nil
2	Fuel/ oil types	JP-5
3	Fuelling facilities/ capacity	To be issued later
4	De-icing facilities	Nil
5	Hangar space for visiting aircraft	Nil
6	Repair facilities for visiting aircraft	Nil
7	Remarks	Nil

**RJFY AD 2.5 PASSENGER FACILITIES**

1	Hotels	Nil
2	Restaurants	Nil
3	Transportation	Nil
4	Medical facilities	Nil
5	Bank and Post Office	Nil
6	Tourist Office	Nil
7	Remarks	Nil

**RJFY AD 2.6 RESCUE AND FIRE FIGHTING SERVICES**

1	AD category for fire fighting	Nil
2	Rescue equipment	Nil
3	Capability for removal of disabled aircraft	Nil
4	Remarks	Nil

**RJFY AD 2.7 SEASONAL AVAILABILITY-CLEARING**

1	Types of clearing equipment	Nil
2	Clearance priorities	Nil
3	Remarks	Nil

**RJFY AD 2.8 APRONS, TAXIWAYS AND CHECK LOCATIONS DATA**

1	Apron surface and strength	To be issued later
2	Taxiway width, surface and strength	To be issued later
3	ACL and elevation	Not available
4	VOR checkpoints	Nil
5	INS checkpoints	Nil
6	Remarks	Nil

**RJFY AD 2.9 SURFACE MOVEMENT GUIDANCE AND CONTROL SYSTEM AND MARKINGS**

1	Use of aircraft stand ID signs, TWY guide lines and Visual docking/ parking guidance system of aircraft stands	Nil
2	RWY and TWY markings and LGT	RWY:08R/26L (LGT) RTHL TWY: (LGT)TWY edge LGT
3	Stop bars	Nil
4	Remarks	

**RJFY AD 2.10 AERODROME OBSTACLES**

RWY/Area affected	Obstacle type	Coordinates	Elevation	Markings/ LGT	Remarks
Nil					

**RJFY AD 2.11 METEOROLOGICAL INFORMATION PROVIDED**

1	Associated MET Office	KANOYA
2	Hours of service MET Office outside hours	H24
3	Office responsible for TAF preparation Periods of validity	Nil
4	Trend forecast Interval of issuance	Nil
5	Briefing/ consultation provided	Nil
6	Flight documentation Language(s) used	Ja, En
7	Charts and other information available for briefing or consultation	S, U
8	Supplementary equipment available for providing information	Nil
9	ATS units provided with information	Nil
10	Additional information(limitation of service, etc.)	Nil

**RJFY AD 2.12 RUNWAY PHYSICAL CHARACTERISTICS**

Designations		Dimensions of RWY(M)	Strength(PCN) and surface of RWY	THR coordinates THR geoid undulation	THR elevation and highest elevation of TDZ of precision APP RWY
RWY NR	TRUE BRG				
1	2	3	4	5	6
08R	079.34°	2250x45	SW43000kg (94800lbs) DW56000kg (123500lbs) DTW117000kg (258000lbs) Concrete	312153.61N 1304938.66E	THR ELEV : 222.4FT TDZ ELEV : 217.6FT
26L	259.35°	2250x45		312207.12N 1305102.36E	THR ELEV : 186.6FT TDZ ELEV : 190.9FT
08L	079.44°	1200x40	SW20000kg (44000lbs)	Nil	Nil
26R	259.45°	1200x40	DW25000kg (35000lbs) Asphalt-Concrete	Nil	Nil
Slope of RWY		Strip Dimensions (M)	Remarks		
7		10	12		
Nil		2370x300 2370x300	RWY 08L/26R OPR SR-SS and VMC only, Other time usable TWY.		
Nil		1320x150 1320x150			

**RJFY AD 2.13 DECLARED DISTANCES**

RWY Designator	TORA (m)	TODA (m)	ASDA (m)	LDA (m)	Remarks
1	2	3	4	5	6

**RJFY AD 2.14 APPROACH AND RUNWAY LIGHTING**

RWY Designator	APCH LGT type LEN INTST	RTHL Color WBAR	PAPI (VASIS) Angle DIST FM THR MEHT	RTZL LEN	RCLL LEN Spacing Color INTST	REDL LEN Spacing Color INTST	RENL Color WBAR	STWL LEN Color
1	2	3	4	5	6	7	8	9
08R			PAPI 3.0° 311m 45ft					Nil
26L	AVBL		PAPI 3.0° 319m 54ft					Nil
08L								Nil
26R								Nil
Remarks								
10								
RWY THR ID LGT for RWY08R/26L THR (Color: White) Usable area of PAPI for RWY08R is within 1NM FM RWY08R THR								

## Usable area of PAPI

滑走路08R末端側進入角指示灯の使用範囲は、障害物(樹木)のため滑走路08R側末端から1NM以内とする。

Usable area of PAPI for RWY 08R is within 1NM from RWY 08R THR due to obstruction(trees)

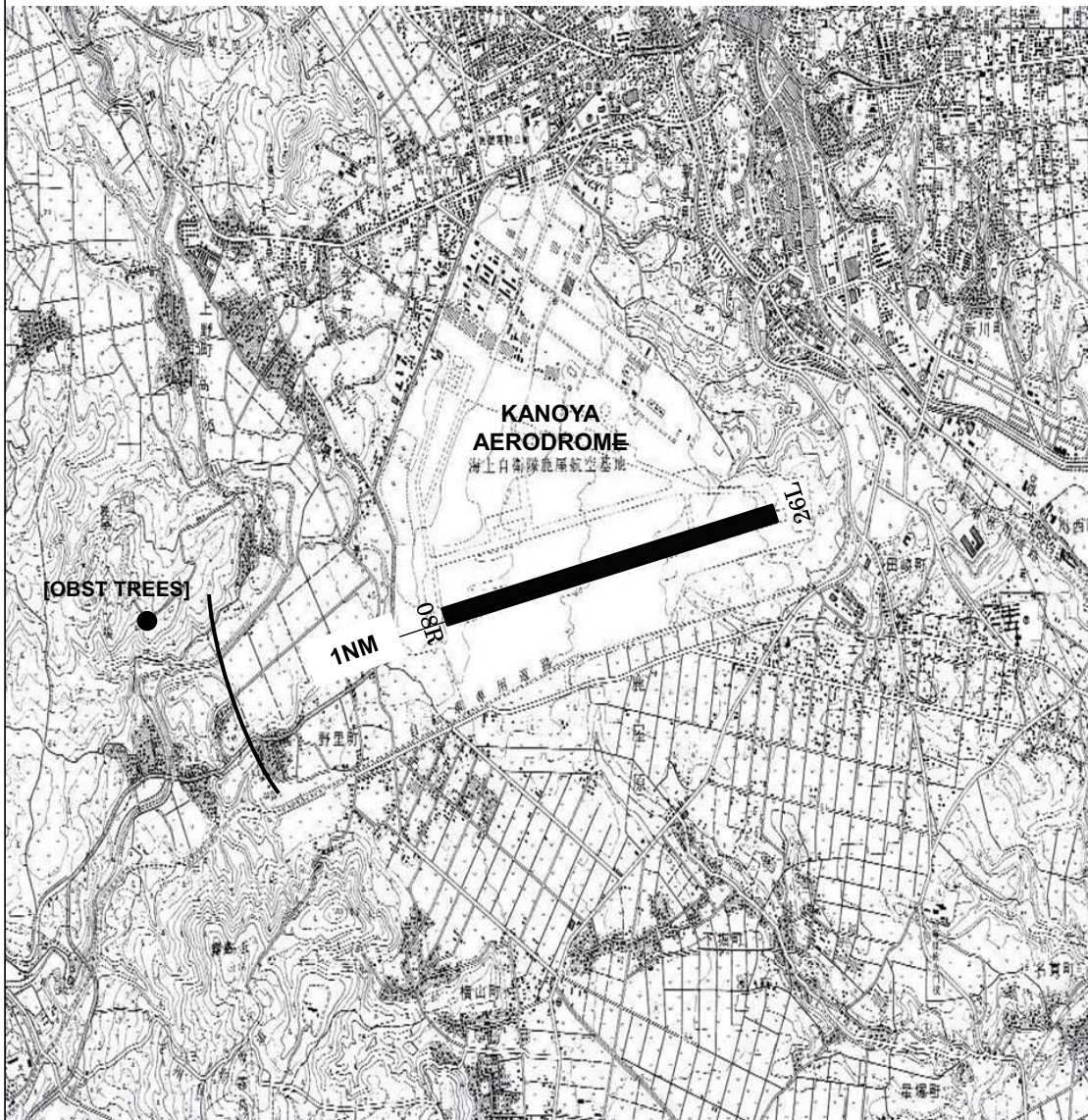

**RJFY AD 2.15 OTHER LIGHTING, SECONDARY POWER SUPPLY**

1	ABN/IBN location, characteristics and hours of operation	ABN:312239N/1305010E, White/Green EV4.3sec, HO
2	LDI location and LGT Anemometer location and LGT	LDI : LGTD
3	TWY edge and center line lighting	TWY edge LGT : AVBL
4	Secondary power supply/ switch-over time	Nil
5	Remarks	WDI LGT, OBST LGT

**RJFY AD 2.16 HELICOPTER LANDING AREA**

To be issued later
--------------------

**RJFY AD 2.17 ATS AIRSPACE**

Designation and limits		Vertical limits (ft)	Airspace classification	ATS unit call sign Language	Remarks
1		2	3	4	6
Kanoya CTR	Area within a radius of 5NM of Kanoya ARP (31°22'N/130°50'E).	----- 5000	D	KANOKA TOWER En	
	Area within radius of 5NM of Kanoya ARP, in the south side of a north parallel line at a distance of 5NM from a line extending from 312121N/1305056E on 077°T and 257°T and in the east side of a east parallel line at a distance of 4NM from a line connecting HKC VOR and TGE VOR.	----- 6000			
Kanoya ACA		See below Chart			

**鹿屋進入管制区  
Kanoya Approach Control Area**

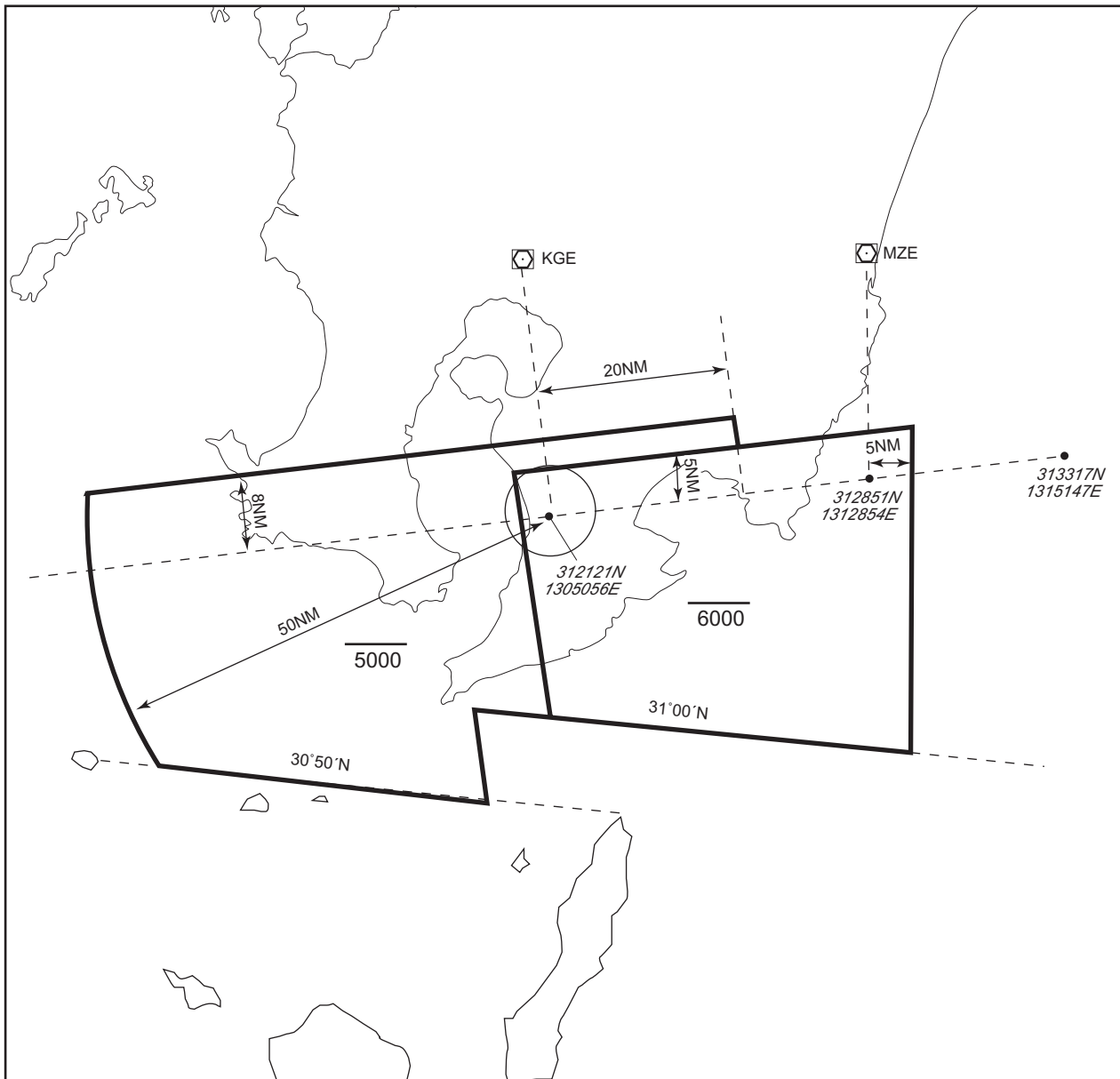



RJFY AD 2.18 ATS COMMUNICATION FACILITIES

Service designation	Call sign	Frequency	Hours of operation	Remarks
1	2	3	4	5
TWR	Kanoya Tower	228.2MHz 133.4MHz 236.8MHz 126.2MHz 243.0MHz(E) 121.5MHz(E)	H24	
DEP/APP/ASR	Kanoya Departure /Kanoya Approach /Kanoya Radar	284.6MHz 122.15MHz 362.3MHz 321.2MHz(1) 261.2MHz(1) 133.0MHz(1) 126.2MHz 243.0MHz(E) 121.5MHz(E)	H24	(1)AVBL on request  Maintenance period: 2300-0800 SAT in VMC
GND	Kanoya Ground	236.8MHz	H24	
GCA-ASR -PAR	Kanoya Radar /Kanoya GCA	335.6MHz 270.8MHz 134.1MHz 125.3MHz 258.6MHz 139.55MHz 317.2MHz 306.8MHz 243.0MHz(E) 121.5MHz(E)	H24	ASR RWY 26L/08R. PAR RWY 26L. Glide path 3.0° Maintenance period: 2300-0800 SAT in VMC. Blind zone lies BTN 175degrees -180degrees , 190degrees - 195degrees and 340degrees - 360degrees 10NM, ARC FM ASR site (312149N/1305004E)
ATIS	Kanoya Airport	246.8MHz	2100 - 1300 EXC FRI1301-SUN2059 AND HOL	

**RJFY AD 2.19 RADIO NAVIGATION AND LANDING AIDS**

Type of aid	ID	Frequency	Hours of operation	Position of transmitting antenna coordinates	Elevation of DME transmitting antenna	Remarks
1	2	3	4	5	6	7
TACAN	JAT	1172 MHz (CH-85X)	H24	312146N/1304949E	252ft	TACAN Unusable: R360-010 beyond 11NM BLW 7000FT. R010-020 beyond 12NM BLW 8000FT. R080-090 beyond 35NM BLW 4000FT. R090-100 beyond 18NM BLW 5000FT. R100-110 beyond 16NM BLW 5000FT. R110-170 beyond 16NM BLW 6000FT. R170-200 beyond 14NM BLW 6000FT. R200-220 beyond 10NM BLW 5000FT. R220-230 beyond 12NM BLW 6000FT. R230-250 beyond 20NM BLW 6000FT. R250-280 beyond 25NM BLW 4000FT. R280-310 beyond 25NM BLW 5000FT. R310-320 beyond 14NM BLW 6000FT. R320-360 beyond 11NM BLW 7000FT.
ILS-LOC 26L	IJA	110.3MHz	H24	312152N/1304930E		LOC:223m (733FT) away FM RWY 08R THR, BRG (MAG) 265°
ILS-GP 26L	-	335MHz	H24	312203N/1305052E		GP:286m(937FT) inside FM RWY 26L THR, 90m(295FT) S of RCL. HGT of ILS Ref datum 15.6m(51FT). GP angle 3.0°.
MM 26L		75MHz	H24	312212.65N/1305135.33E		MM:888m(2913FT) away FM RWY 26L on the extended RCL.

**ILS**

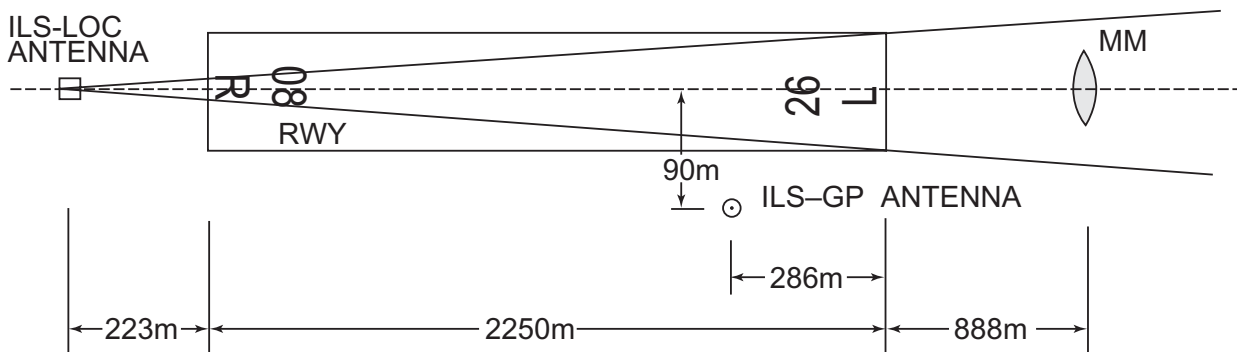

REMARKS : 1.LOC beam BRG(MAG) 265°  
 2.HGT of ILS REF datum 15.6m(51FT)  
 3.GP Angle 3.0°

---

**RJFY AD 2.20 LOCAL TRAFFIC REGULATIONS**

1. Airport regulations

Nil

2. Taxiing to and from stands

Nil

3. Parking area for small aircraft(General aviation)

Nil

4. Parking area for helicopters

Nil

5. Apron - taxiing during winter conditions

Nil

6. Taxiing - limitations

Nil

7. School and training flights - technical test flights - use of runways

Nil

8. Helicopter traffic - limitation

Nil

9. Removal of disabled aircraft from runways

Nil

**RJFY AD 2.21 NOISE ABATEMENT PROCEDURES**

Nil

**RJFY AD 2.22 FLIGHT PROCEDURES**

1. TAKE OFF MINIMA					
	RWY	REDL AVBL		REDL OUT	
		CEIL-RVR	CEIL-VIS	CEIL-RVR	CEIL-VIS
TKOF ALTN AP FILED	08R	-	300'-1600m	-	300'-1600m
	26L	-	700'-2400m	-	700'-2400m
OTHER	08R	AVBL LDG MINIMA			
	26L				

NOTE: SIDs are designed in accordance with provisional standards for FLIGHT PROCEDURE DESIGN.

**2. WX MINIMA CONCERNING PAR/ASR APCH PROCEDURE**

ASR RWY 08R

MINIMA	THR elev. 222		AD elev. 202	
CAT	CIRCLING			
	MDA(H)	CMV	MDA(H)	VIS
A	980(778)	1500	980(778)	1600
B				2400
C		2000	1380(1178)	3200
D				3200

ASR RWY 26L

MINIMA	THR elev. 187		AD elev. 202	
CAT	CIRCLING			
	MDA(H)	RVR/ CMV	MDA(H)	VIS
A	720(533)	1400	940(738)	1600
B		1500		
C		1600	1380(1178)	2400
D		1800		3200

PAR RWY 26L

MINIMA	THR elev. 187		AD elev. 202	
CAT	CIRCLING			
	DA(H)	RVR/ CMV	MDA(H)	VIS
A	450(263)	800	940(738)	1600
B				
C			1380(1178)	2400
D				3200

**3. Lost communication procedures for arrival aircraft under radar navigational guidance**

If radio communications with KANOYA Radar/Approach/GCA are lost for 1 minute in the pattern or 5 seconds (PAR)/15 seconds (ASR) on final approach, squawk ModeA/3 Code 7600 and;

- (I) 1. Contact KANOYA Tower.
- 2. If unable, proceed in accordance with visual flight rules.
- 3. If unable,
  - (1) In the vector
    - a. Proceed to DAGRI at last assigned altitude or 3,000ft whichever is higher and execute instrument approach as follows:
      - TACAN Z RWY26L, ILS Y or LOC Y RWY26L.
    - b. Proceed to TILAN at last assigned altitude or 3,200ft whichever is higher and execute TACAN RWY08R approach.
  - (2) On final approach
    - Execute instrument final approach.
- (II) Procedures other than above will be issued when situation required.

NOTE: On dog leg(235 DEG/2200) under GCA, execute final approach as follows:  
TACAN Z RWY26L, ILS Z or LOC Z RWY26L.

**4. Automated Radar Terminal System (ARTS)**

鹿屋進入管制所の指示のもとに、鹿屋進入管制区を飛行する航空機は、モード A/3 の二次レーダー個別コード及びモード C による応答を指示される。

モード A/3 又はモード C 応答用の ATC トランスポンダーを搭載していない航空機が、当該モードによる応答を指示された場合は、鹿屋進入管制所に対しその旨通報すること。

Aircraft flying within the approach control area under the control of KANOYA approach control will be instructed to reply with discrete code on Mode A/3 and Mode C. If an aircraft non equipped with ATC transponder A/3 or Mode C instructed to reply with such Mode, it shall report KANOYA approach control accordingly.

**RJFY AD 2.23 ADDITIONAL INFORMATION**

481FT height group of trees exist near APCH surface 1.13NM WNW FM RWY08R THR.

**RJFY AD 2.24 CHARTS RELATED TO AN AERODROME**

Standard Departure Chart - Instrument (EAST REVERSAL)  
Standard Departure Chart - Instrument (WEST REVERSAL)  
Standard Departure Chart - Instrument (EKORU)  
Standard Departure Chart - Instrument (MAKRA)  
Standard Departure Chart - Instrument (QUEEN)  
Standard Arrival Chart - Instrument (AIRAH)  
Instrument Approach Chart (ILS Z or LOC Z RWY 26L)  
Instrument Approach Chart (ILS Y or LOC Y RWY 26L)  
Instrument Approach Chart (ILS X or LOC X RWY 26L)  
Instrument Approach Chart (TACAN Z RWY 26L)  
Instrument Approach Chart (TACAN Y RWY 26L)  
Instrument Approach Chart (TACAN RWY 08R)

**INTENTIONALLY LEFT BLANK**

STANDARD DEPARTURE CHART - INSTRUMENT

RJFY / KANOYA

SID

EAST REVERSAL TWO DEPARTURE

RWY08R : Climb via JAT R083 to 4000FT or above within 13NM  
 from RWY end(JAT 14DME), then turn right proceed to JAT TACAN.  
 RWY26L : Not established.

Note:

- 1 Following climb gradient should be maintained until passing 2000FT.

Speed (Knots)	60	90	120	150	180	210
Rate (Feet/Min)	300	450	600	750	900	1050

- 2 SHIBUSHI PETROLEUM COMBINAT at JAT R094 10DME.
- 3 Obstructions exist,
  - a 229FT MSL height group of trees at 0.76NM E from ARP.
  - b 1934FT MSL height mountain at 10.8NM ESE from ARP.

CHANGE : PROC renamed. NDB (JA) deleted. Radial FM JAT (SHIBUSHI PETROLEUM COMBINAT).

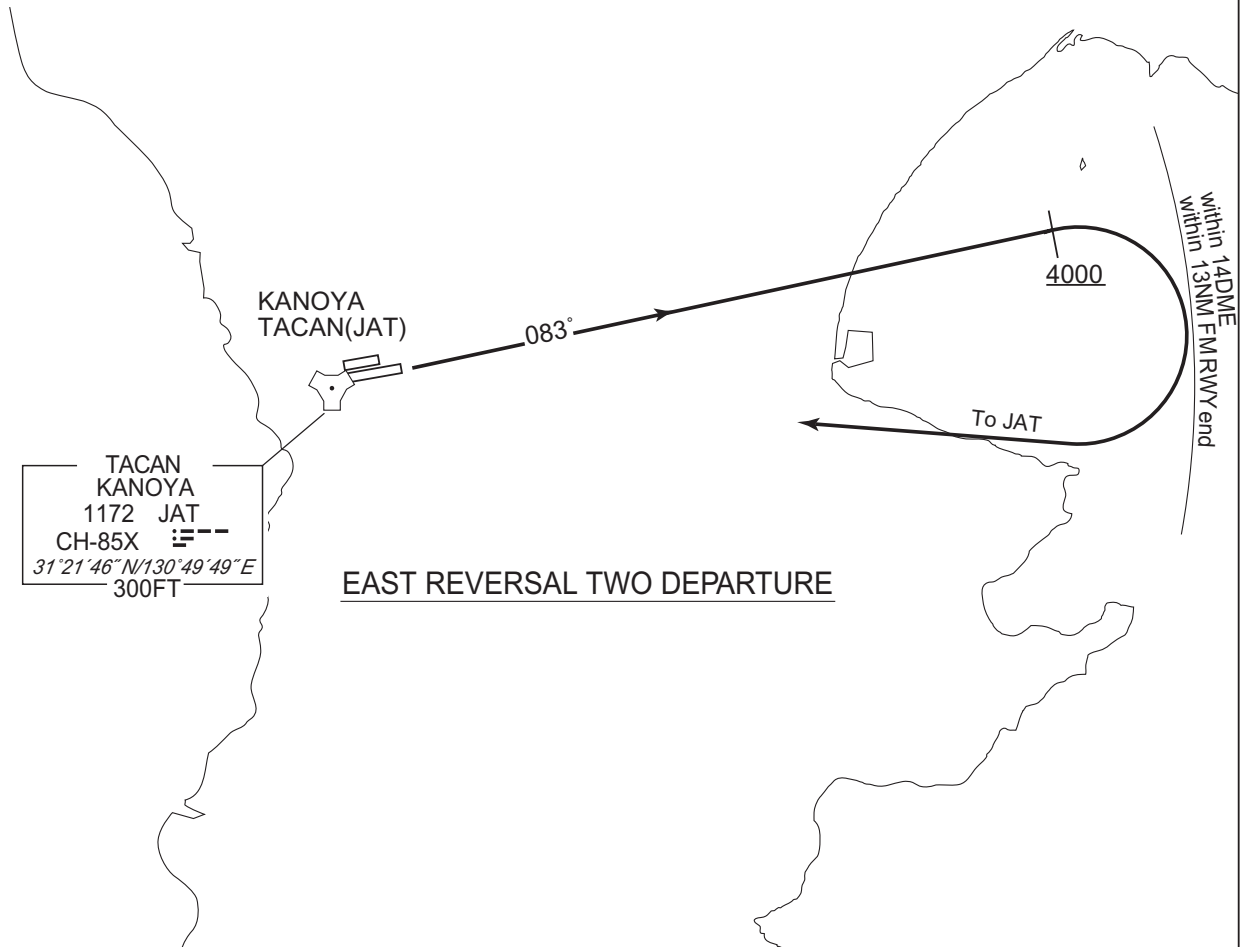

STANDARD DEPARTURE CHART - INSTRUMENT

RJFY / KANOYA

SID

WEST REVERSAL TWO DEPARTURE

RWY08R : Not established.

RWY26L : Climb via JAT R270 to 4000FT or above within 13NM from RWY end (JAT 13DME), then turn left proceed to JAT TACAN.

Note:

- 1 Following climb gradient should be maintained until passing 600FT.

Speed (Knots)	60	90	120	150	180	210
Rate (Feet/Min)	300	450	600	750	900	1050

- 2 Obstructions exist,

- a 582FT MSL height hill at 1NM SW from ARP.
- b 630FT MSL height antenna tower at 1.1NM SW from ARP.
- c 493FT MSL height antenna tower at 1.8NM W from ARP.
- d 555FT MSL height hill at 2.2NM W from ARP.

CHANGE : SID (RWY26L). Note:2 Obstructions. NDB (JA) deleted.

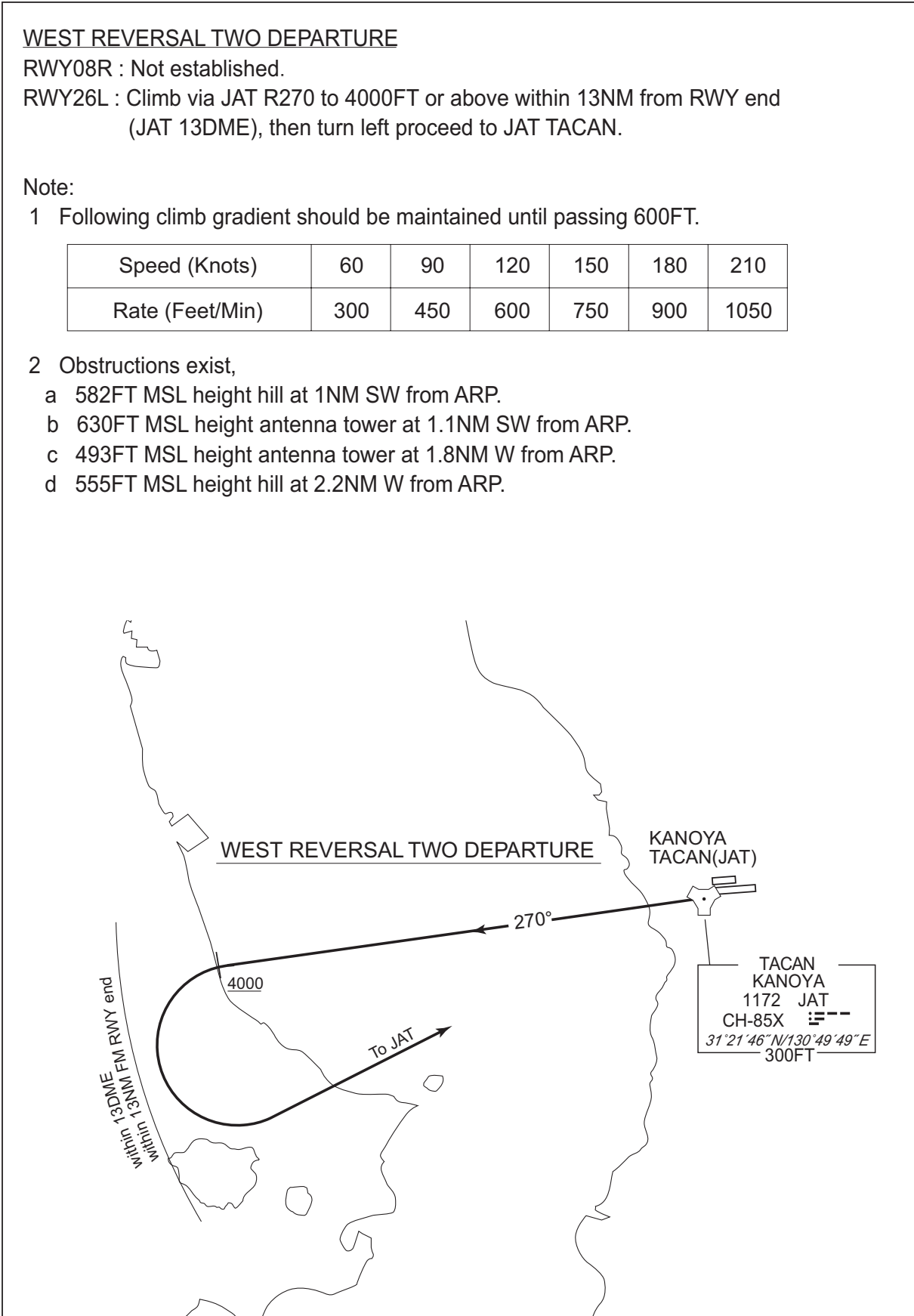



STANDARD DEPARTURE CHART - INSTRUMENT

RJFY / KANOYA

SID

EKORU ONE DEPARTURE

RWY08R : Climb via JAT R084 to EKORU.

RWY26L : Climb RWY HDG until 3.5NM from RWY end (JAT 3.6DME) to 1000FT or above, turn left proceed to JAT TACAN, via JAT R084 to EKORU.

Note:

- 1 Following climb gradient should be maintained,
  - a until passing 2000FT when take off RWY08R.
  - b until passing 1600FT when take off RWY26L.

Speed (Knots)	60	90	120	150	180	210
Rate (Feet/Min)	300	450	600	750	900	1050

2 SHIBUSHI PETROLEUM COMBINAT at JAT R094 10DME.

3 Obstructions exist,

- a when take off RWY08R,
  - (a)229FT MSL height group of trees at 0.76NM E from ARP.
  - (b)1934FT MSL height mountain at 10.8NM ESE from ARP.
- b when take off RWY26L,
  - (a)582FT MSL height hill at 1NM SW from ARP.
  - (b)630FT MSL height antenna tower at 1.1NM SW from ARP.
  - (c)493FT MSL height antenna tower at 1.8NM W from ARP.
  - (d)555FT MSL height hill at 2.2NM W from ARP.
  - (e)814FT MSL height mountain at 3.0NM SW from ARP.
  - (f)837FT MSL height mountain at 3.2NM SW from ARP.
  - (g)1378FT MSL height mountain at 3.5NM S from ARP.
  - (h)1582FT MSL height mountain at 3.9NM S from ARP.

CHANGE : New PROC

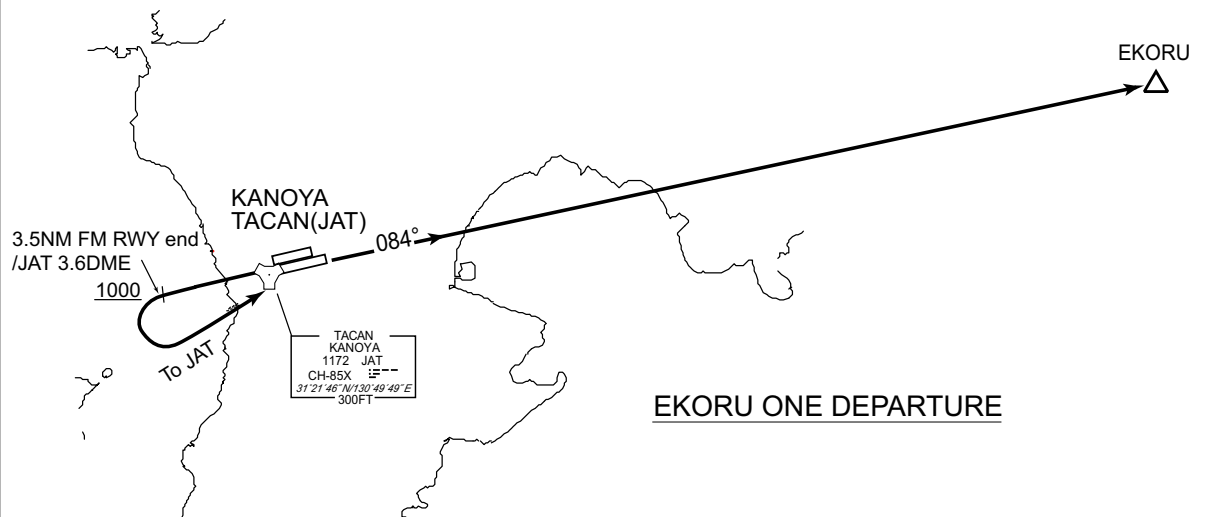

STANDARD DEPARTURE CHART - INSTRUMENT

RJFY / KANOYA

SID

MAKRA THREE DEPARTURE

RWY08R : Not established.

RWY26L : Climb RWY HDG until 1NM from RWY end (JAT 1.0DME), climb via JAT R263 to MAKRA.

Note:

- 1 Following climb gradient should be maintained until passing 600FT.

Speed (Knots)	60	90	120	150	180	210
Rate (Feet/Min)	300	450	600	750	900	1050

- 2 Obstructions exist,

- a 493FT MSL height antenna tower at 1.8NM W from ARP.
- b 555FT MSL height hill at 2.2NM W from ARP.

CHANGE : PROC renamed. NDB(JA) abolished.

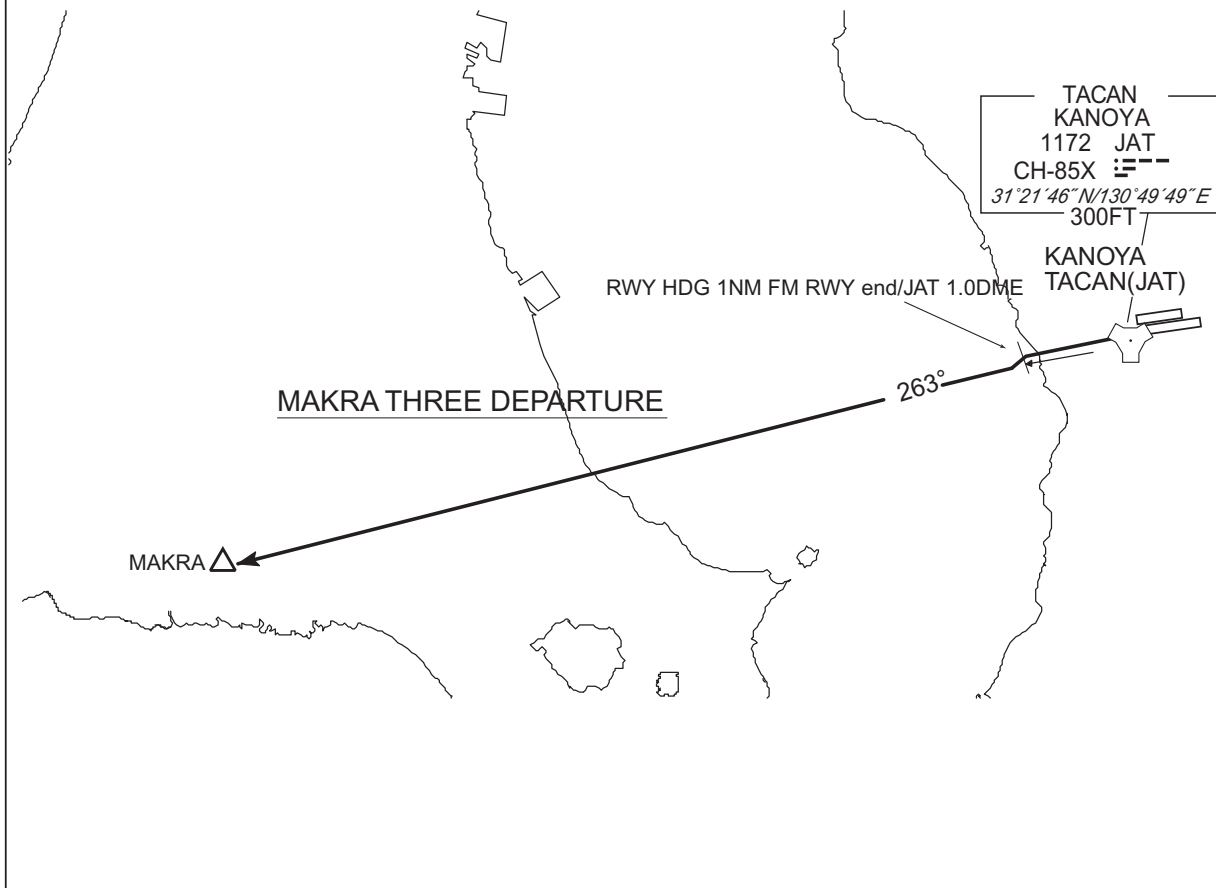

STANDARD DEPARTURE CHART - INSTRUMENT

RJFY / KANOYA

SID

**QUEEN FOUR DEPARTURE**

RWY08R : Climb via JAT R083 to intercept and proceed via HKC R127 to QUEEN.

RWY26L : Climb RWY HDG until 3.5NM from RWY end (JAT 3.6DME) to 1000FT or above, turn left proceed to JAT TACAN then, climb via JAT R083 to intercept and proceed via HKC R127 to QUEEN.

Note:

- 1 Following climb gradient should be maintained,
  - a. until passing 2000FT when take off RWY08R.
  - b. until passing 3000FT when take off RWY26L.

Speed (Knots)	60	90	120	150	180	210
Rate (Feet/Min)	300	450	600	750	900	1050

2 SHIBUSHI PETROLEUM COMBINAT at JAT R094 10DME.

- 3 Obstructions exist,
  - a. when take off RWY08R,
    - (a)229FT MSL height group of trees at 0.76NM E from ARP.
    - (b)1934FT MSL height mountain at 10.8NM ESE from ARP.
  - b. when take off RWY26L,
    - (a)582FT MSL height hill at 1NM SW from ARP.
    - (b)630FT MSL height antenna tower at 1.1NM SW from ARP.
    - (c)493FT MSL height antenna tower at 1.8NM W from ARP.
    - (d)555FT MSL height hill at 2.2NM W from ARP.
    - (e)814FT MSL height mountain at 3.0NM SW from ARP.
    - (f)837FT MSL height mountain at 3.2NM SW from ARP.
    - (g)1378FT MSL height mountain at 3.5NM S from ARP.
    - (h)1582FT MSL height mountain at 3.9NM S from ARP.
    - (i)2907FT MSL height mountain at 10NM SE from ARP.

CHANGE : PROC renamed. Radial FM HKC.

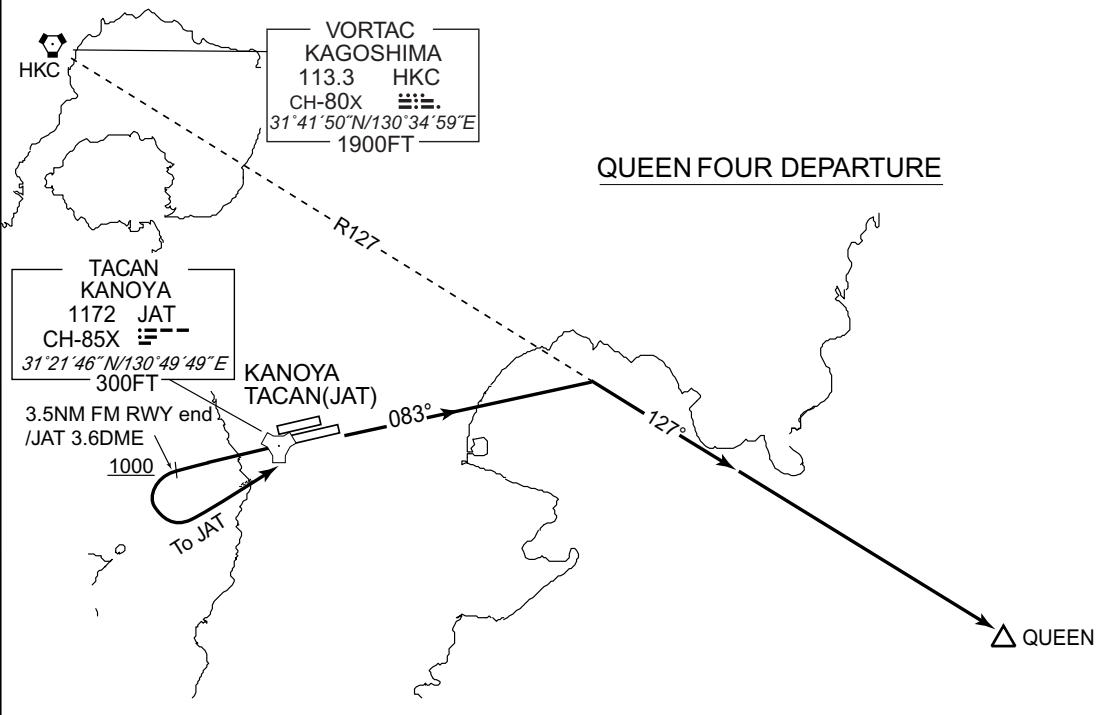

**INTENTIONALLY LEFT BLANK**

STANDARD ARRIVAL CHART - INSTRUMENT

RJFY / KANOYA

STAR

AIRAH ARRIVAL

From over JAT TACAN, proceed via JAT R125 to AIRAH (JAT R125 16.0DME), maintain last assigned altitude until 2DME from JAT TACAN, cross AIRAH at or above 6000FT or specified altitude.

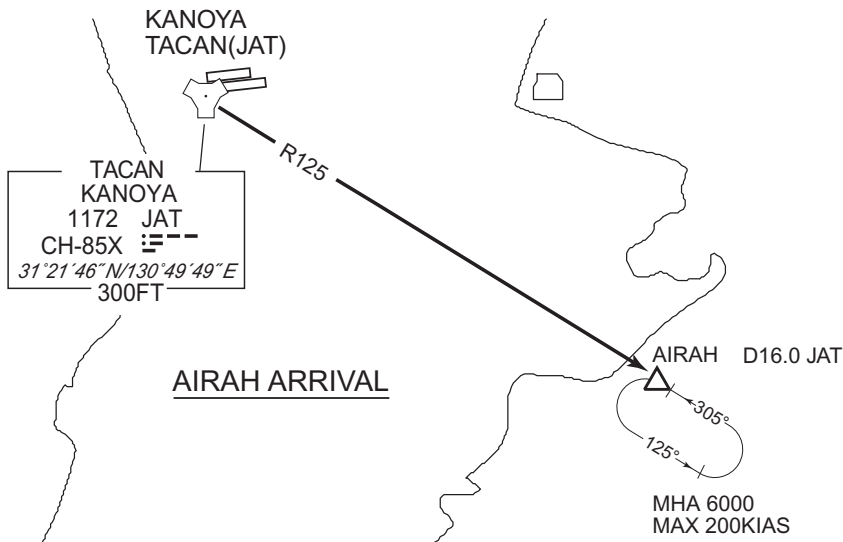

CHANGE : KANOYA ARRIVAL abolished.

**INTENTIONALLY LEFT BLANK**

INSTRUMENT APPROACH CHART

RJFY / KANOYA

ILS Z or LOC Z RWY 26L

KANOYA APP 122.15 - 126.2 284.6 - 321.2	ILS / LOC 110.3 IJA ☰--- ILS-GP 335.0	KANOYA TOWER 126.2 - 133.4 228.2 - 236.8	RADAR AVBL CALL KANOYA APP
---	---	--	----------------------------------

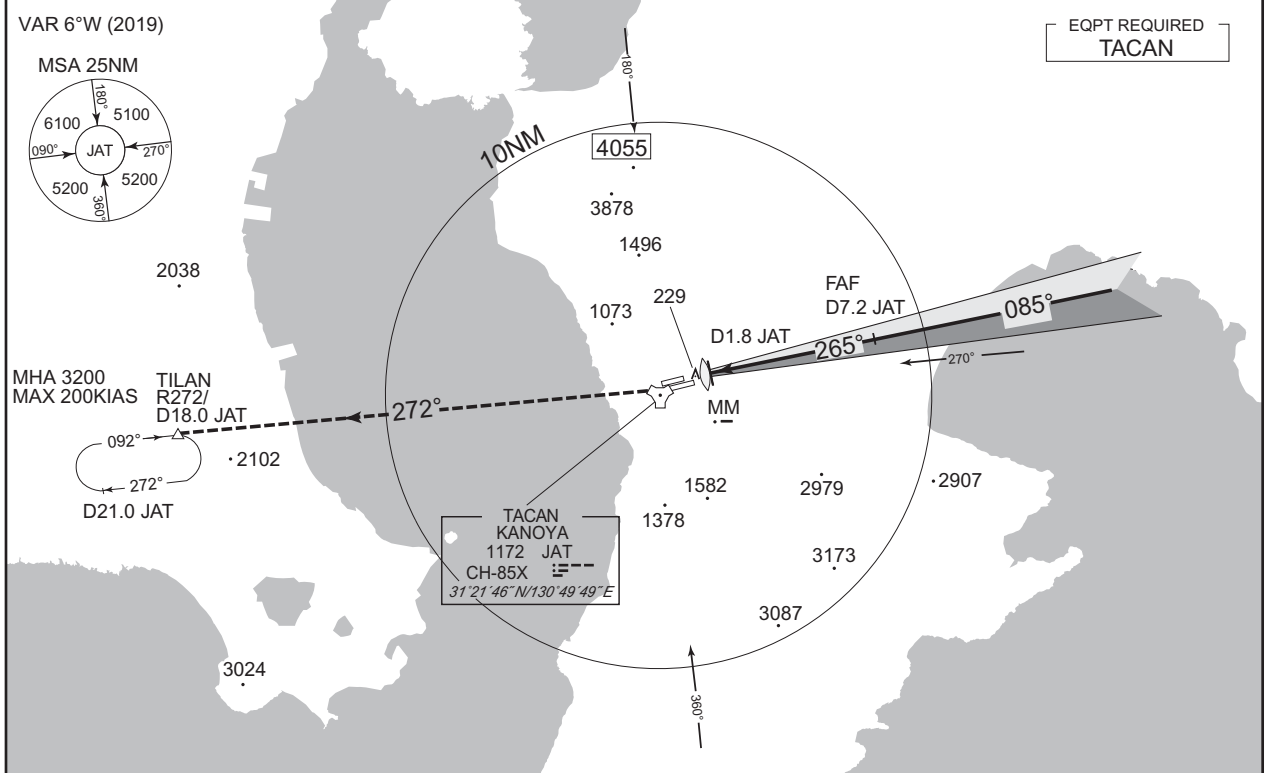

MISSED APPROACH

At DA, climb to 3200FT via JAT R272 to TILAN and hold.  
Contact KANOYA APP.



DME to JAT  
NM to THR

1.8  
0.7

7.2  
6.1

CHANGE : MDA(H) for circling. OBST HGHT(1207→1073).

MINIMA		THR elev. 187		AD elev. 202		
CAT	CAT I		LOC		CIRCLING	
	DA(H)	RVR/CMV	MDA(H)	RVR/CMV	MDA(H)	VIS
A	450 (263)	800	680 (493)	1400	940 (738)	1600
B				1500		
C				1600	1380 (1178)	
D				1800		

INSTRUMENT APPROACH CHART

RJFY / KANOYA

ILS Y or LOC Y RWY 26L

KANOYA APP 122.15 - 126.2 284.6 - 321.2	ILS / LOC 110.3 IJA $\equiv$ --- ILS - GP 335.0	KANOYA TOWER 126.2 - 133.4 228.2 - 236.8	RADAR AVBL CALL KANOYA APP
---	---	--	----------------------------------

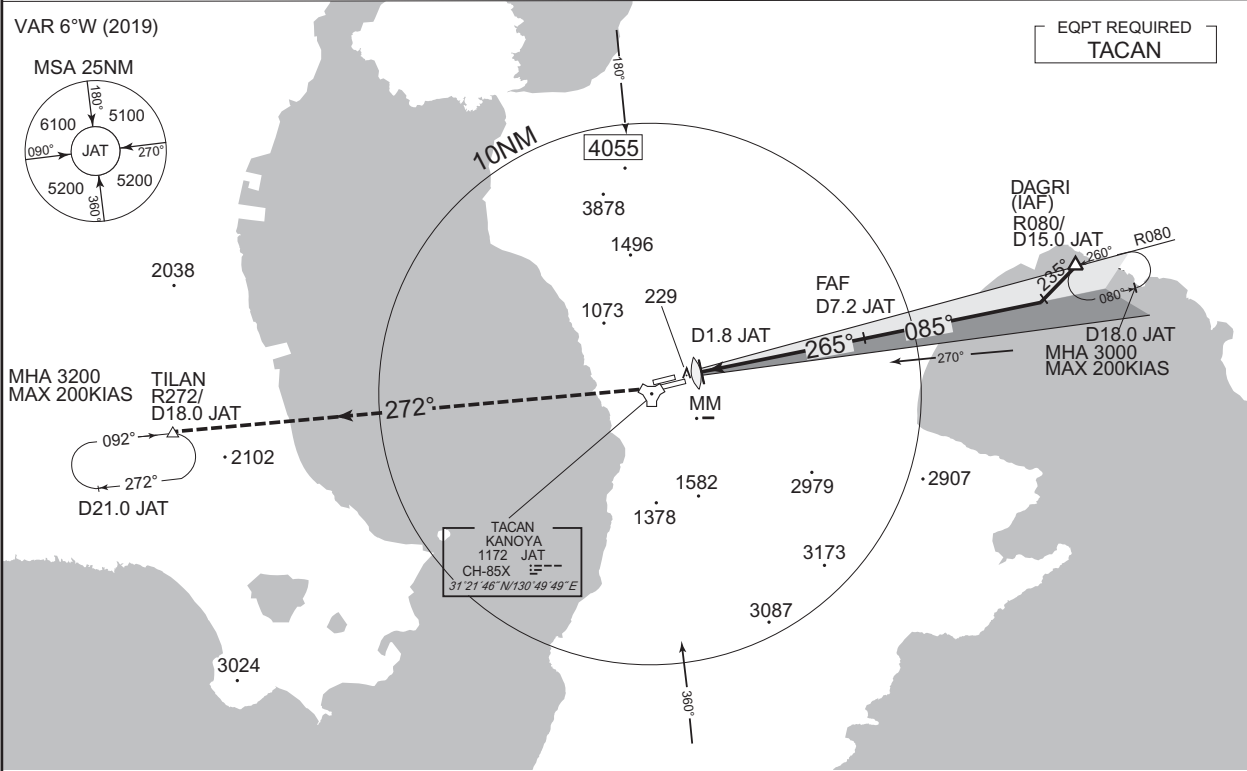

MISSED APPROACH

At DA, climb to 3200FT via JAT R272 to TILAN and hold. Contact KANOYA APP.

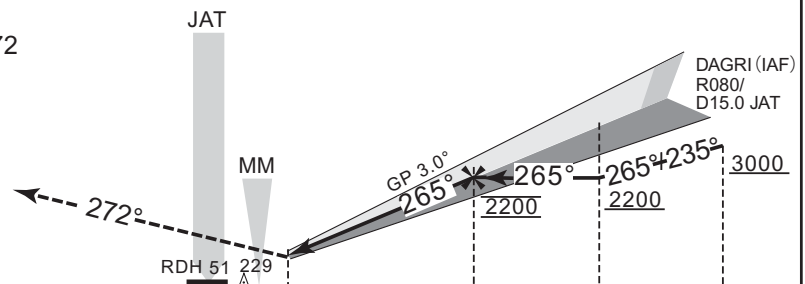

DME to JAT	1.8	7.2	10.0
NM to THR	0.7	6.1	8.9

CAT	THR elev. 187		AD elev. 202				
	CAT I		LOC		CIRCLING		
	DA(H)	RVR/CMV	MDA(H)	RVR/CMV	MDA(H)	VIS	
A	450 (263)	800	680 (493)	1400	940 (738)	1600	
B				1500			
C				1600	1380 (1178)		2400
D				1800			3200

CHANGE : MDA(H) for circling. OBST HGT(1207→1073).



INSTRUMENT APPROACH CHART

RJFY / KANOYA ILS X or LOC X RWY 26L

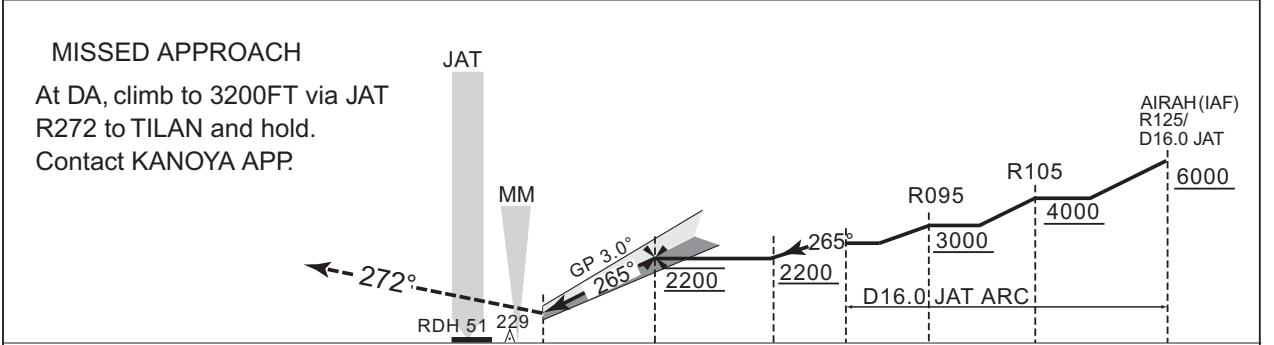
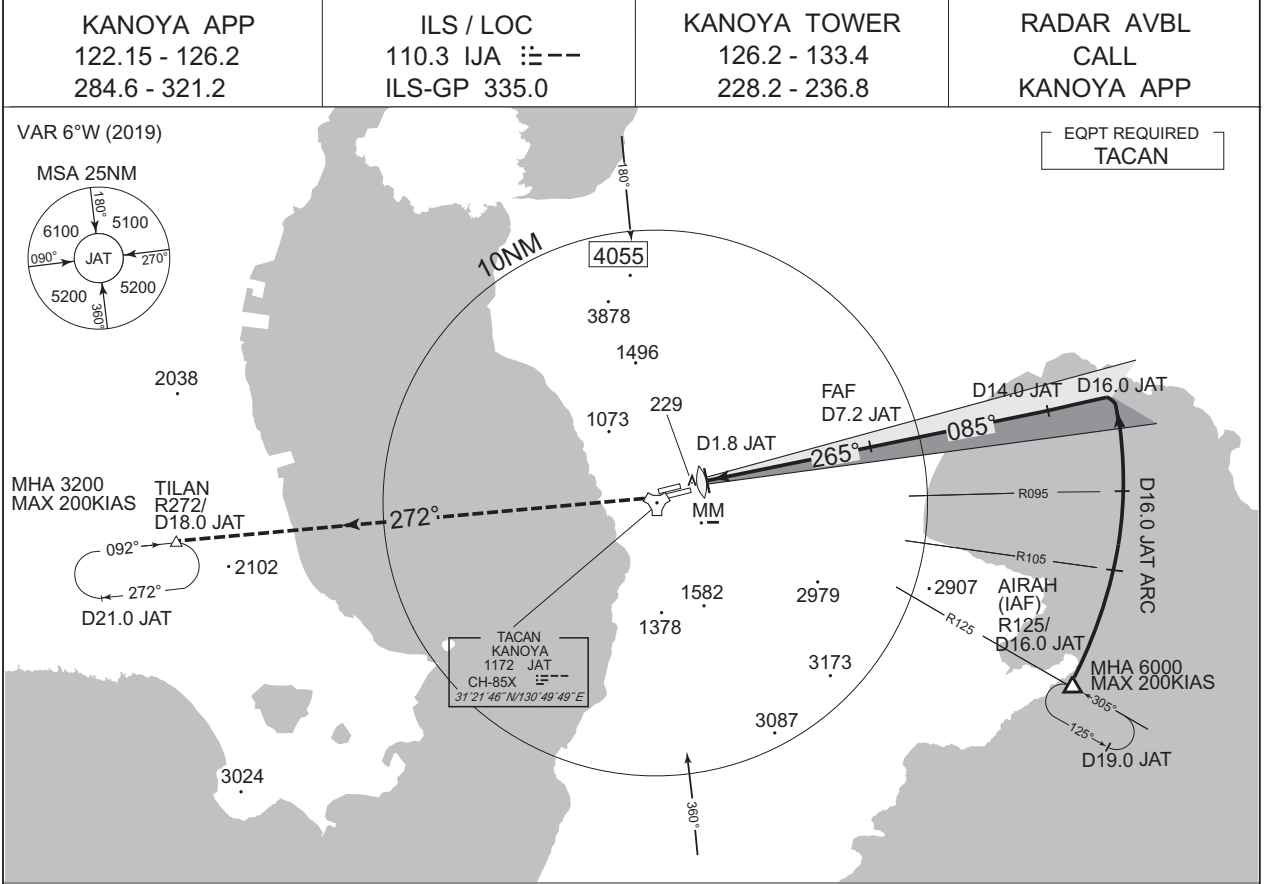

DME to JAT	1.8	7.2	14.0	16.0
NM to THR	0.7	6.1	12.9	14.9

MINIMA		THR elev. 187		AD elev. 202			
CAT	CAT I		LOC		CIRCLING		
	DA(H)	RVR/CMV	MDA(H)	RVR/CMV	MDA(H)	VIS	
A	450 (263)	800	680 (493)	1400	940 (738)	1600	
B				1500			
C				1600	1380 (1178)		2400
D				1800			3200

CHANGE : MDA(H) for circling. OBST HGT(1207→1073).

INSTRUMENT APPROACH CHART

RJFY / KANOYA

TACAN Z RWY 26L

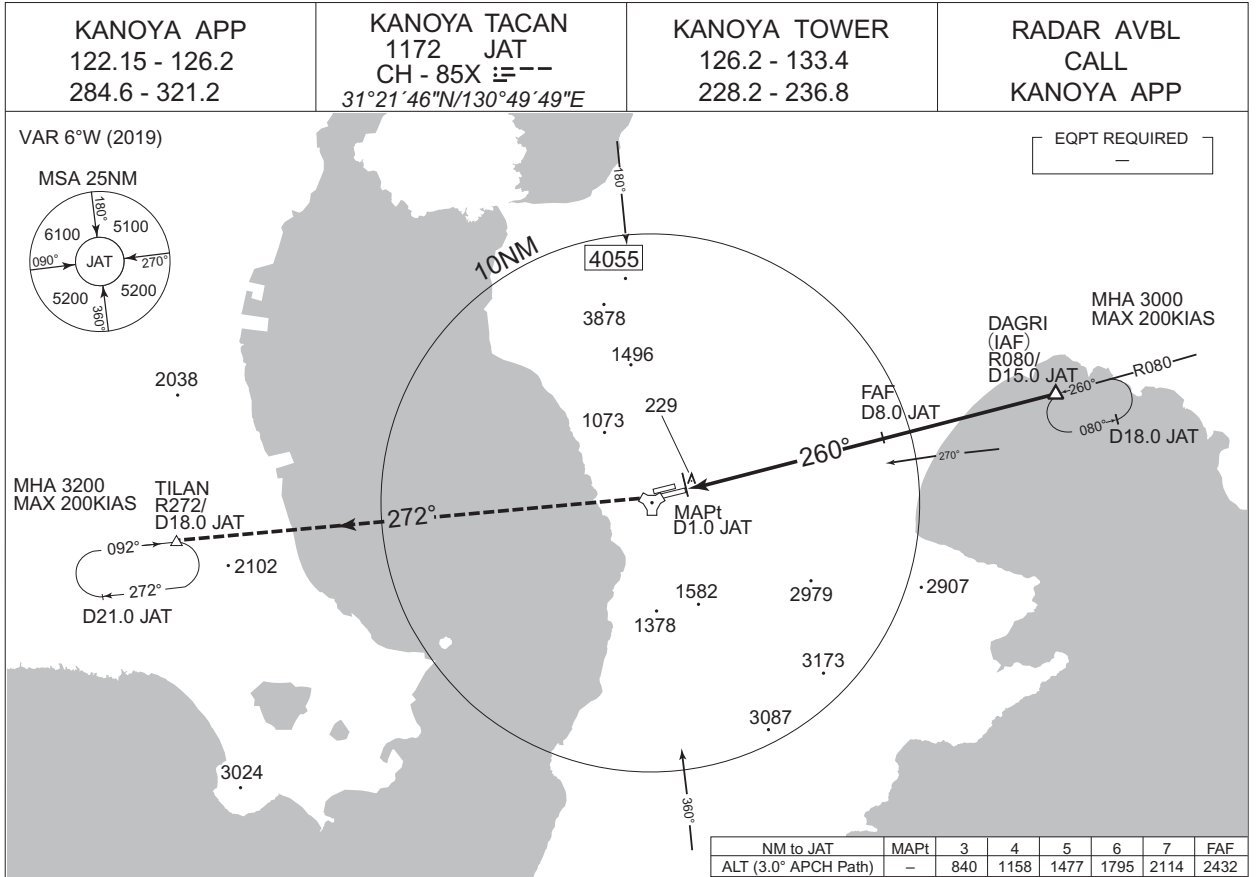

MISSED APPROACH

At 1.0DME prior to JAT TACAN, climb to 3200FT via JAT R272 to TILAN and hold. Contact KANOYA APP.

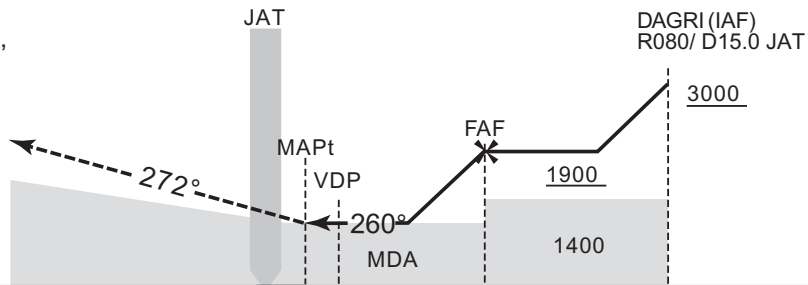

DME to JAT	1.0	2.7	8.0	15.0
NM to THR	1.6	6.9	13.9	

MINIMA      THR elev. 187      AD elev. 202

CAT	CIRCLING		MDA(H)	VIS
	MDA(H)	RVR/CMV		
A	700 (513)	1400	940 (738)	1600
B		1500		
C		1600	1380 (1178)	2400
D		1800		

CHANGE : MDA(H) for circling. OBST HGT(1207→1073).

INSTRUMENT APPROACH CHART

RJFY / KANOYA

TACAN Y RWY 26L

KANOYA APP 122.15 - 126.2 284.6 - 321.2	KANOYA TACAN 1172 JAT CH-85X ≡-- 31°21'46" N/130°49'49"E	KANOYA TOWER 126.2 - 133.4 228.2 - 236.8	RADAR AVBL CALL KANOYA APP
---	---	--	----------------------------------

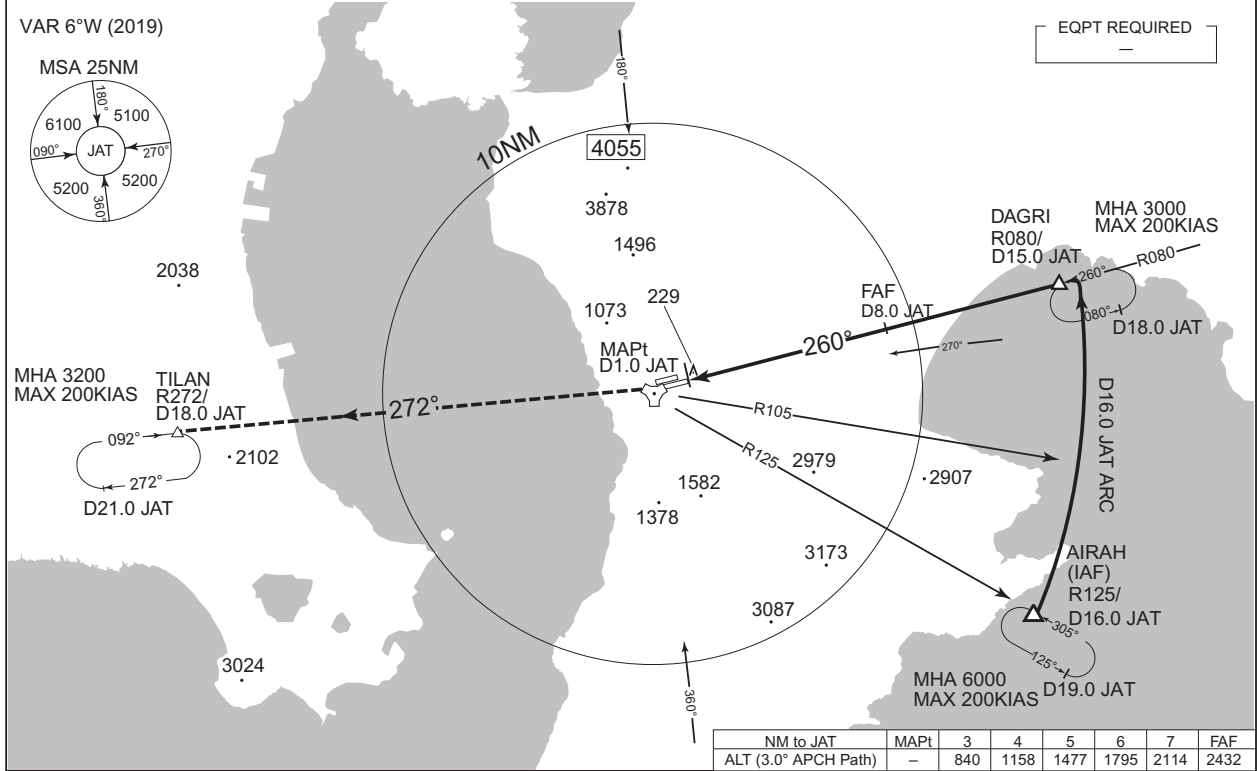

MISSED APPROACH

At 1.0DME prior to JAT TACAN, climb to 3200FT via JAT R272 to TILAN and hold. Contact KANOYA APP.

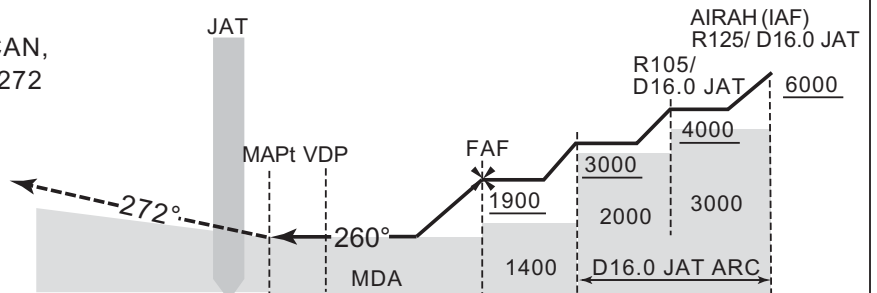

DME to JAT	1.0	2.7	8.0	16.0
NM to THR	1.6	6.9	14.9	

MINIMA		THR elev. 187	AD elev. 202	
CAT			CIRCLING	
	MDA(H)	RVR/CMV	MDA(H)	VIS
A	700 (513)	1400	940 (738)	1600
B		1500		
C		1600	1380 (1178)	2400
D		1800		

CHANGE : MDA(H) for circling. OBST HGT(1207→1073).

INSTRUMENT APPROACH CHART

RJFY / KANOYA

TACAN RWY 08R

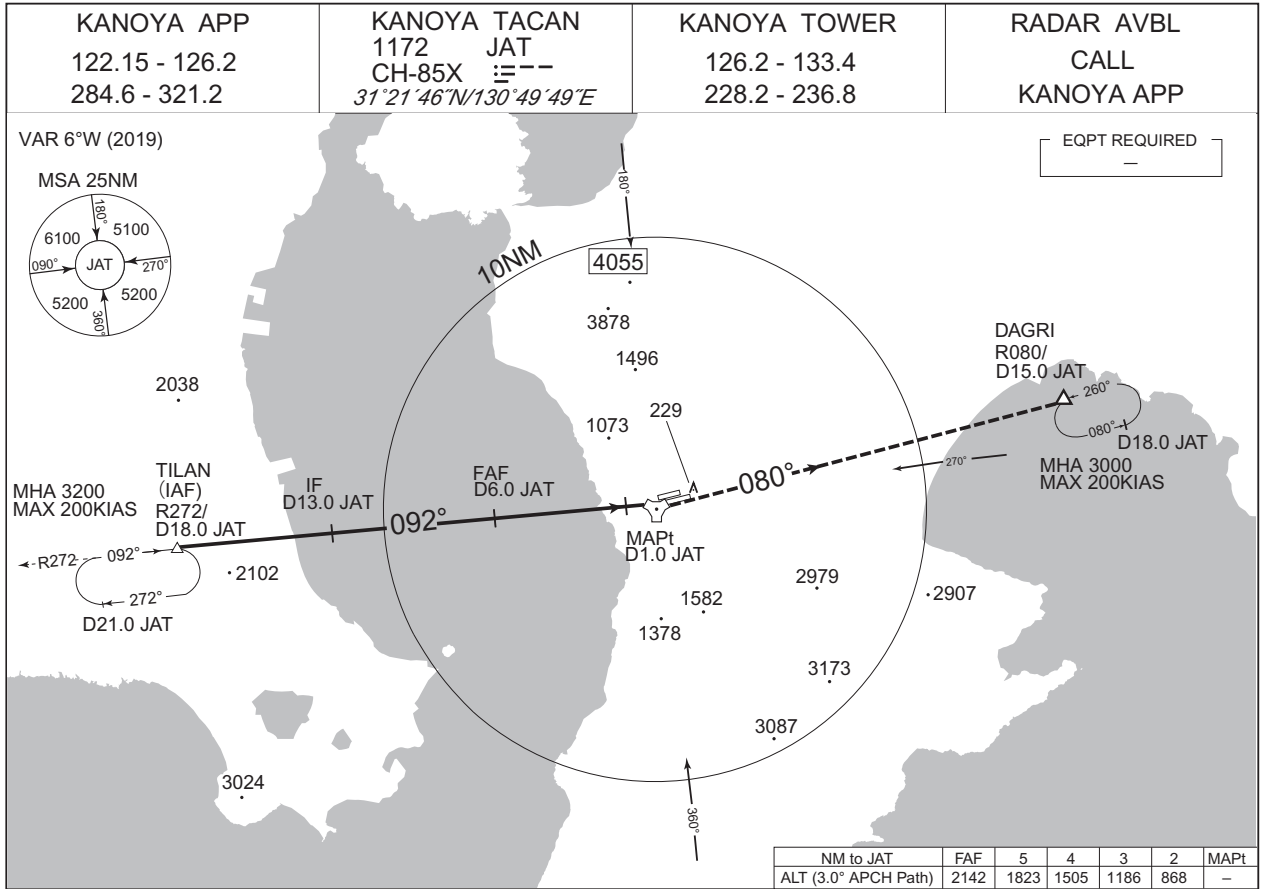

CHANGE : MDA(H) for circling. OBST HGT(1207→1073).

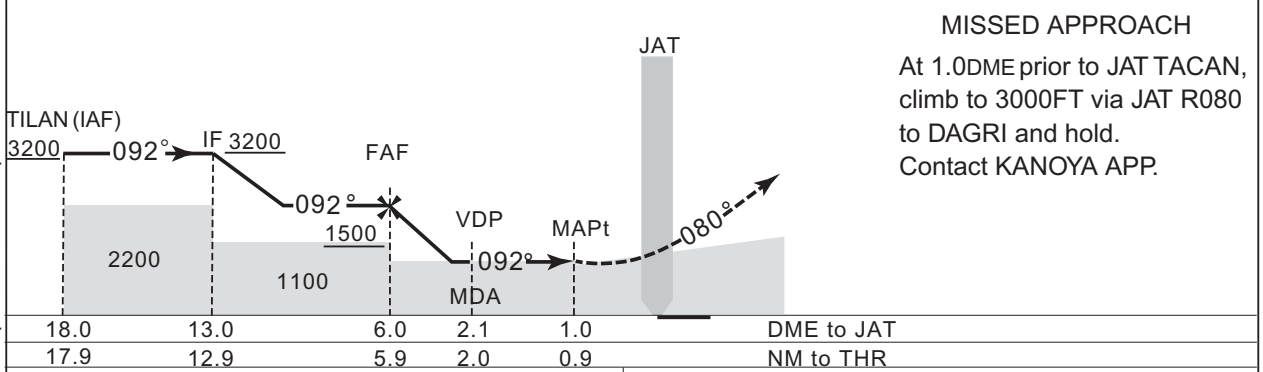

**MISSED APPROACH**  
 At 1.0DME prior to JAT TACAN, climb to 3000FT via JAT R080 to DAGRI and hold. Contact KANOYA APP.

<b>MINIMA</b>	THR elev. 222	AD elev. 202		
CAT	CIRCLING			
	MDA(H)	CMV	MDA(H)	VIS
A	860 (658)	1500	940 (738)	1600
B				2400
C				3200
D		2000	1380 (1178)	