

AD 2 AERODROMES

RJNW AD 2.1 AERODROME LOCATION INDICATOR AND NAME

RJNW - NOTO

RJNW AD 2.2 AERODROME GEOGRAPHICAL AND ADMINISTRATIVE DATA

1	ARP coordinates and site at AD	371736N/1365744E 067°/1.0km FM RWY 07 THR
2	Direction and distance from (city)	6.4NM SSE of WAJIMA city
3	Elevation/ Reference temperature	718ft / 28°C (2003-2005)
4	Geoid undulation at AD ELEV PSN	123ft
5	MAG VAR/ Annual change	9°W(2022)/ 4.2°W
6	AD Administration, address, telephone, telefax, telex, AFS, e-mail and/or Web-site addresses	Noto Airport Management Office 10-11-1, Sue, Mii-machi, Wajima-City, Ishikawa Pref. 929-2392, JAPAN Tel: 0768-26-2100 Fax: 0768-26-2102
7	Types of traffic permitted (IFR/ VFR)	IFR/VFR
8	Remarks	Nil

RJNW AD 2.3 OPERATIONAL HOURS

1	AD Administration	2300 - 1030
2	Customs and immigration	On request Customs: 0767-52-0689 Immigration: 076-222-2450
3	Health and sanitation	Quarantine(human): On request(0761-21-3767) Quarantine(animal, plant): Nil
4	AIS Briefing Office	Nil
5	ATS Reporting Office(ARO)	Nil
6	MET Briefing Office	H24 (TOKYO)
7	ATS	2300 - 1030 Remarks: AFIS provided by Osaka Airport Office.
8	Fuelling	2330 - 0830
9	Handling	0000 - 0800
10	Security	0130 - 0700
11	De-icing	Nil
12	Remarks	Nil

RJNW AD 2.4 HANDLING SERVICES AND FACILITIES

1	Cargo-handling facilities	All the modern institutions that deal with the weight thing to Boeing 737 type and Airbus A320 type.
2	Fuel/ oil types	Fuel grades : JET A1
3	Fuelling facilities/ capacity	Fuel Truck Refuelling/100KL
4	De-icing facilities	Nil
5	Hangar space for visiting aircraft	Nil
6	Repair facilities for visiting aircraft	Nil
7	Remarks	Nil

RJNW AD 2.5 PASSENGER FACILITIES

1	Hotels	Nil
2	Restaurants	At airport
3	Transportation	Busses, Taxi
4	Medical facilities	Hospital in Wajima city 12km
5	Bank and Post Office	Nil
6	Tourist Office	At airport
7	Remarks	Nil

RJNW AD 2.6 RESCUE AND FIRE FIGHTING SERVICES

1	AD category for fire fighting	CAT 7
2	Rescue equipment	Chemical fire fighting truck X 2
3	Capability for removal of disabled aircraft	Ask AD administration
4	Remarks	Nil

RJNW AD 2.7 SEASONAL AVAILABILITY-CLEARING

1	Types of clearing equipment	Snow remove equipments: 5 motor graders
2	Clearance priorities	(1)RWY (2)TWY (3)Apron
3	Remarks	Seasonal availability: all seasons Snow removed will be commenced, if RWY and TWY are covered with a depth of 3cm snow or more.

RJNW AD 2.8 APRONS, TAXIWAYS AND CHECK LOCATIONS DATA

1	Apron surface and strength	Surface : concrete, Strength: PCN 55/R/C/X/T
2	Taxiway width, surface and strength	Width : 23m, Surface : Asphalt, Strength: PCN 53/F/B/X/T
3	ACL and elevation	Not available
4	VOR checkpoints	Not available
5	INS checkpoints	Spot NR 1 371740.11N, 1365723.55E 2 371740.72N, 1365725.32E 3 371741.39N, 1365727.28E 4 371742.00N, 1365729.05E
6	Remarks	Nil

RJNW AD 2.9 SURFACE MOVEMENT GUIDANCE AND CONTROL SYSTEM AND MARKINGS

1	Use of aircraft stand ID signs, TWY guide lines and Visual docking/ parking guidance system of aircraft stands	Nil
2	RWY and TWY markings and LGT	RWY:RWY07/25 (Marking) RWY designation, RWY CL, RWY THR, RWY middle point, Aiming point, TDZ, RWY side stripe, RWY turn pad CL, RWY turn pad edge (LGT) RCLL, REDL, RTHL, RENL, RTZL(RWY25), WBAR(RWY), Turning point indicator LGT, RWY DIST marker LGT TWY: (Marking) TWY CL, TWY side stripe, RWY HLDG PSN (LGT) TWY edge LGT, TWY CL LGT
3	Stop bars	Nil
4	Remarks	(Marking) Overrun area edge (LGT) APN flood LGT

RJNW / NOTO

180° Turn on RWY

滑走路180°転回要領

1. 滑走路中心線からターニングパッド中心線標識に従って進行する。
2. 転回灯1が一直線に見えるように進行し、転回灯2が一直線に見えた時転回を開始する。
転回時はMAX STEERING ANGLEを使用する。

180°turn on runway

1. Proceed along the RWY Turn Pad Center Line Marking.
2. Proceed along the RWY Turn Pad Center Line Marking to see the Turning Point Indicator Light 1 on a straight line, then commence turn at the spot where you (pilot) can see the Turning Point Indicator Light 2 on a straight line at an angle of 9 o'clock.
When turning, take MAX STEERING ANGLE.

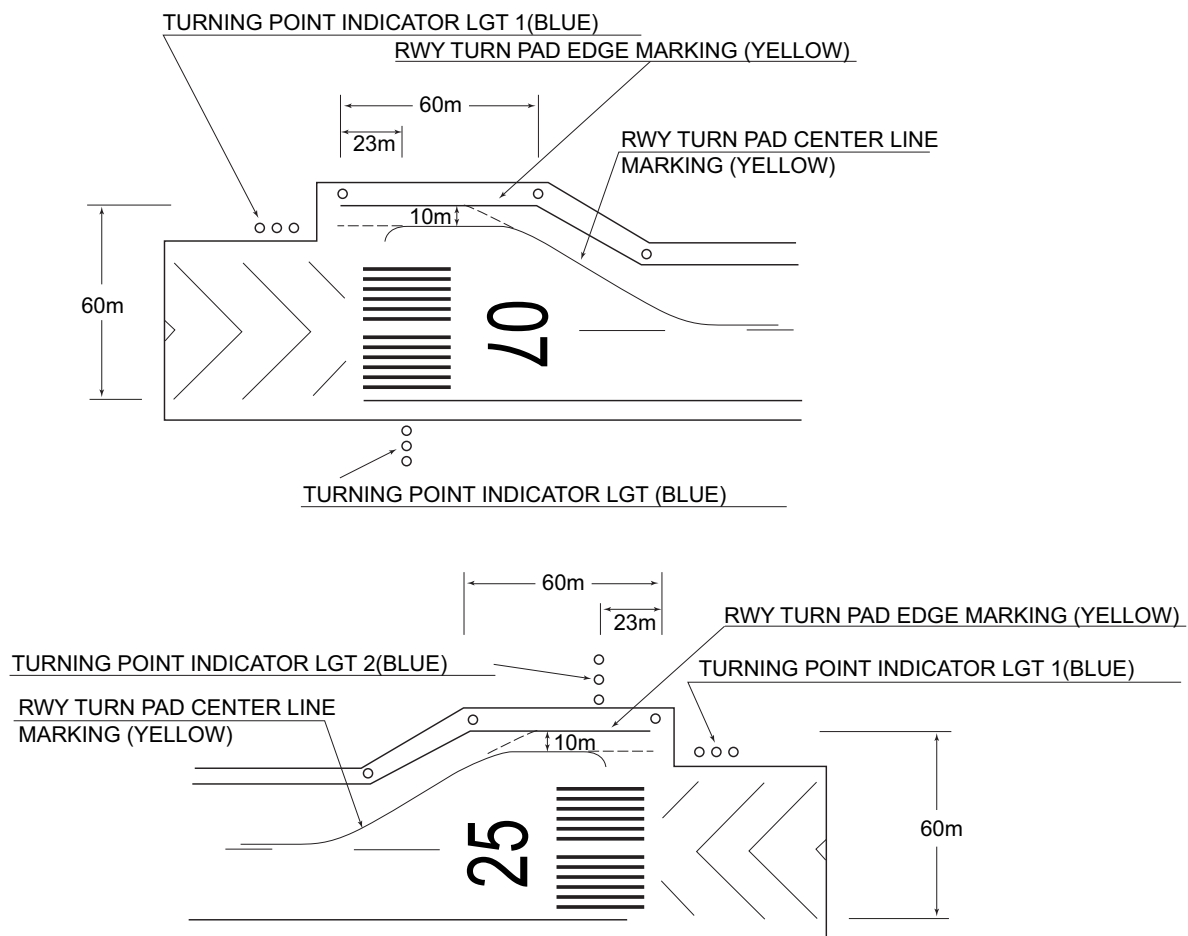

RJNW AD 2.10 AERODROME OBSTACLES

In Area2 See Obstacle data

Other obstacles

OBST ID/ designation	Obstacle type	Coordinates	Elevation	Markings/ LGT	Remarks
RJNW1	Building	371735N/1365711E	775ft	-/LIL	Under transition SFC

In Area3 To be developed

RJNW AD 2.11 METEOROLOGICAL INFORMATION PROVIDED

1	Associated MET Office	TOKYO
2	Hours of service MET Office outside hours	H24 (TOKYO)
3	Office responsible for TAF preparation Periods of validity	Nil
4	Trend forecast Interval of issuance	Nil
5	Briefing/ consultation provided	Briefing is available upon inquiry at TOKYO
6	Flight documentation Language(s) used	C En
7	Charts and other information available for briefing or consultation	S ₆ , U ₈₅ , U ₇ , U ₅ , U ₃ , U ₂₅ , U _{2/T} , P _S , P ₅ , P ₃ , P ₂₅ , P _{SWE} , P _{SWF} , P _{SWG} , P _{SWI} , P _{SWM} , P _{SW} (domestic), E, C, W _E , W _F , W _G , W _I , W, N
8	Supplementary equipment available for providing information	Nil
9	ATS units provided with information	RADIO
10	Additional information (limitation of service, etc.)	Nil

RJNW AD 2.12 RUNWAY PHYSICAL CHARACTERISTICS

Designations RWY NR	TRUE BRG	Dimensions of RWY(M)	Strength(PCN) and surface of RWY	THR coordinates THR geoid undulation	THR elevation and highest elevation of TDZ of precision APP RWY
1	2	3	4	5	6
07	066.77°	2000x45	PCN 53/F/B/X/T Asphalt-Concrete	371722.92N 1365706.38E 123ft	THR ELEV: 710ft
25	246.77°	2000x45	PCN 53/F/B/X/T Asphalt-Concrete	371748.52N 1365821.00E 123ft	THR ELEV: 702ft TDZ ELEV: 716.6ft
Slope of RWY	Strip Dimensions (M)	RESA (Overrun) Dimensions (M)	Remarks		
7	10	11	14		
See AD2.24 AD chart	2120x300 2120x300	40x(MNM:251 MAX:300)* 190x(MNM:180 MAX:300)*	RWY Grooving: 2000m x 30m		
*For detail, ask airport administrator					

RJNW AD 2.13 DECLARED DISTANCES

RWY Designator	TORA (m)	TODA (m)	ASDA (m)	LDA (m)	Remarks
1	2	3	4	5	6
07	2000	2000	2000	2000	Nil
25	2000	2000	2000	2000	Nil

RJNW AD 2.14 APPROACH AND RUNWAY LIGHTING

RWY Designator	APCH LGT type LEN INTST	RTHL Color WBAR	PAPI (VASIS) Angle DIST FM THR MEHT	RTZL LEN	RCLL LEN Spacing Color INTST	REDL LEN Spacing Color INTST	RENL Color WBAR	STWL LEN Color
1	2	3	4	5	6	7	8	9
07	SALS (*1) 420m LIH	Green -	PAPI 3.0° /LEFT 334.8m 61ft	Nil	2000m 30m Coded color (White/Red) LIH	2000m 60m Coded color (White/Yellow) LIH	Red	Nil (*2)
25	PALS (CAT I) 900m LIH	Green Green	PAPI 3.0° /LEFT 340.3m 61ft	900m	2000m 30m Coded color (White/Red) LIH	2000m 60m Coded color (White/Yellow) LIH	Red	Nil (*2)
Remarks								
10								
SALS with APCH LGT beacon(590m and 860m FM RWY 07 THR)(*1) Overrun area edge LGT(LEN:60m, Color:Red)(*2)								

RJNW AD 2.15 OTHER LIGHTING, SECONDARY POWER SUPPLY

1	ABN/IBN location, characteristics and hours of operation	ABN: 371744N/1365718E, White/Green EV4.3sec, HO
2	LDI location and LGT Anemometer location and LGT	LDI:Nil Anemometer: RWY 07 : 376m FM RWY 07 THR, LGTD RWY 25 : 295m FM RWY 25 THR, LGTD
3	TWY edge and center line lighting	TWY edge and center line lights installed, see AD2.9
4	Secondary power supply/ switch-over time	Within 1sec: REDL, RTHL, WBAR, RENL, RCLL, Overrun area edge LGT, Turning point indicator LGT. Within 15sec: Other LGT
5	Remarks	WDI LGT

RJNW AD 2.16 HELICOPTER LANDING AREA

Nil

RJNW AD 2.17 ATS AIRSPACE

Designation and lateral limits		Vertical limits (ft)	Airspace classification	ATS unit call sign Language	Remarks
1		2	3	4	6
Noto Information Zone	Area within a radius of 5NM(9km) of Noto ARP	4,000 or below	E	NOTO RADIO En	

RJNW AD 2.18 ATS COMMUNICATION FACILITIES

Service designation	Call sign	Frequency	Hours of operation	Remarks
1	2	3	4	5
AFIS	NOTO RADIO	118.05MHz	2300 - 1030	Operated by Osaka Airport Office.

RJNW AD 2.19 RADIO NAVIGATION AND LANDING AIDS

Type of aid (VOR declination)	ID	Frequency	Hours of operation	Position of transmitting antenna coordinates	Elevation of DME transmitting antenna	Remarks
1	2	3	4	5	6	7
VOR (8W°/2017)	NTE	111.45MHz	H24	371723.86N/ 1365746.48E		
DME	NTE	1138MHz (CH-51Y)	H24	371723.86N/ 1365746.48E	793ft	DME unusable: 000°-010° beyond 30nm BLW 4,000ft. 010°-030° beyond 35nm BLW 4,000ft. 350°-360° beyond 35nm BLW 4,000ft.
ILS-LOC 25	INT	108.95MHz	2300 - 1030	371720.07N/ 1365658.08E		LOC: 223m(732ft) away FM RWY 07 THR, BRG(MAG)255°
ILS-GP 25	-	329.15MHz	2300 - 1030	371741.30N/ 1365812.31E		GP: 287m(942ft) inside FM RWY 25 THR, 120m(394ft) S of RCL GP angle 3.0° HGT of ILS REF datum 16.5m (54ft).
ILS-DME 25	INT	1113MHz (CH-26Y)	2300 - 1030	371740.89N/ 1365812.03E	715ft	DME: 299m(981ft)inside FM RWY 25 THR, 130m(427ft) S of RCL
MSAS		1575.42MHz	H24			Transmitting antennas are satellite based.

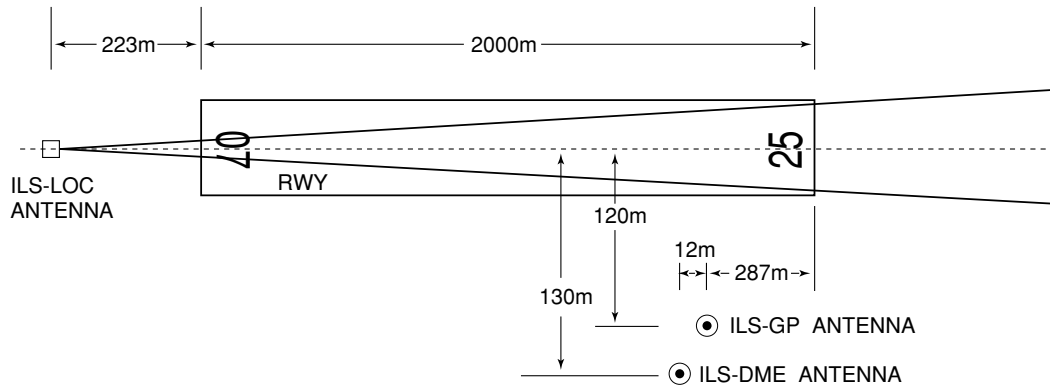

- REMARKS :
- | | |
|--------------------------|---------------|
| 1. ILS-LOC beam BRG(MAG) | 255° |
| 2. HGT of ILS REF datum | 16.5m(54ft) |
| 3. GP Angle | 3.0° |
| 4. ELVE of ILS-DME | 217.7m(715ft) |

RJNW AD 2.20 LOCAL TRAFFIC REGULATIONS

1. Airport regulations

Nil

2. Taxiing to and from stands

Nil

3. Parking area for small aircraft(General aviation)

Nil

4. Parking area for helicopters

Nil

5. Apron - taxiing during winter conditions

Nil

6. Taxiing - limitations

Nil

7. School and training flights - technical test flights - use of runways

Nil

8. Helicopter traffic - limitation

Nil

9. Removal of disabled aircraft from runways

Nil

RJNW AD 2.21 NOISE ABATEMENT PROCEDURES

Nil

RJNW AD 2.22 FLIGHT PROCEDURES

TAKE OFF MINIMA

	RWY	ACFT CAT	REDL & RCLL		REDL or RCLL or RCL Marking		NIL (DAYTIME ONLY)	
			CEIL-RVR	CEIL-VIS	CEIL-RVR	CEIL-VIS	CEIL-RVR	CEIL-VIS
Multi-Engine ACFT with TKOF ALTN AP FILED	07	A,B,C,D	-	200'-800m	-	200'-800m	-	200'-800m
	25	A,B,C,D	0'-400m	0'-400m	0'-400m	0'-400m	-	0'-500m
OTHER	07	A,B,C,D	AVBL LDG MINIMA					
	25	A,B,C,D						

RJNW AD 2.23 ADDITIONAL INFORMATION

Nil

RJNW AD 2.24 CHARTS RELATED TO AN AERODROME

Aerodrome/Heliport Chart
 Standard Departure Chart - Instrument (HISUI)
 Standard Departure Chart - Instrument (URUSI)
 Standard Arrival Chart - Instrument (GORYU)
 Standard Arrival Chart - Instrument (KILCO-RNAV)
 Instrument Approach Chart (ILS Z or LOC Z RWY25)
 Instrument Approach Chart (ILS Y or LOC Y RWY25)
 Instrument Approach Chart (VOR RWY25)
 Instrument Approach Chart (VOR RWY07)
 Instrument Approach Chart (RNP Z RWY07(AR))
 Instrument Approach Chart (RNP Y RWY07(AR))
 Other Chart (Visual REP)
 Other Chart (MVA CHART)

RJNW / NOTO

AD CHART

CHANGE : VAR.

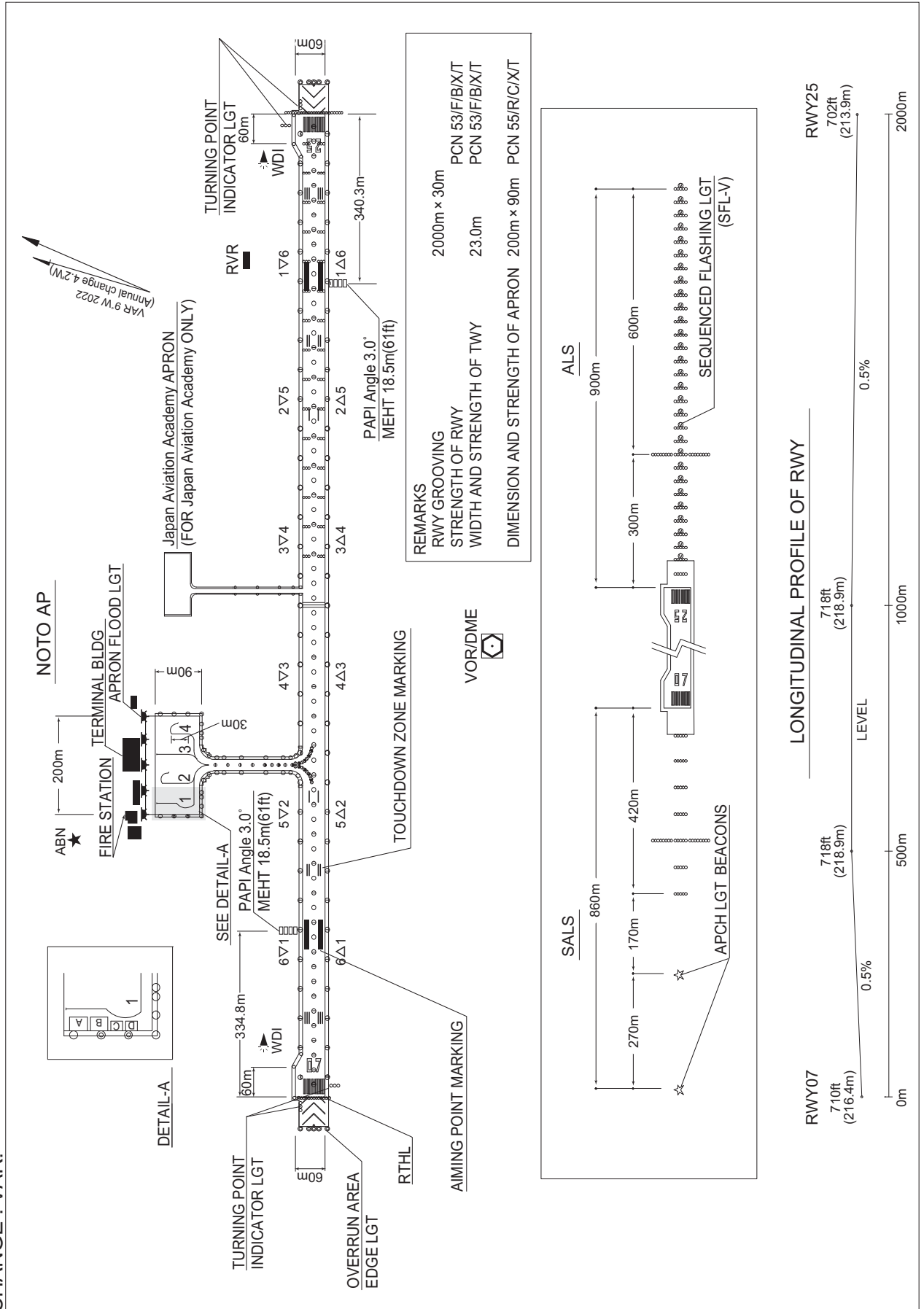

STANDARD DEPARTURE CHART -INSTRUMENT

RJNW / NOTO

SID

HISUI THREE DEPARTURE

RWY07 : Climb RWY HDG to 1300FT, turn right...

RWY25 : Climb RWY HDG to 1200FT, turn left HDG 032° ...
...to intercept and proceed via NTE R077 to HISUI.

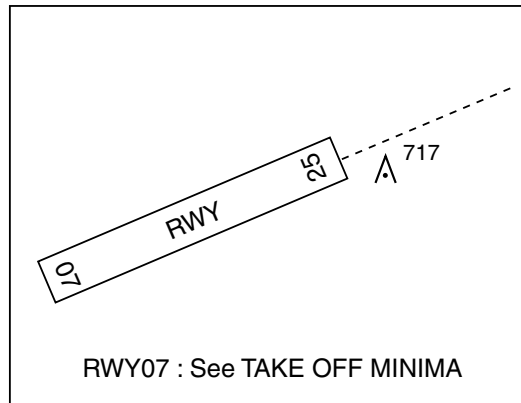
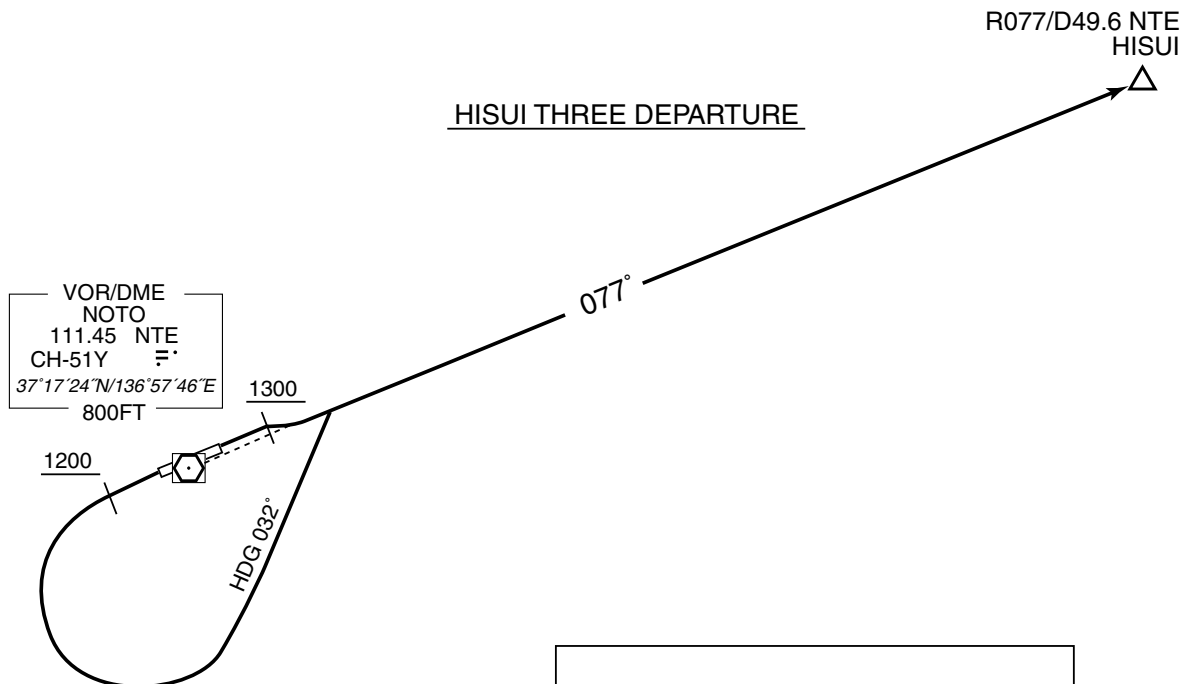

STANDARD DEPARTURE CHART -INSTRUMENT

RJNW / NOTO

SID

URUSI ONE DEPARTURE

RWY07 : Climb RWY HDG to 1300FT, turn right HDG217° ...

RWY25 : Climb RWY HDG to 1200FT, turn left HDG127° ...
...to intercept and proceed via NTE R172 to URUSI.

Cross URUSI at or above 8000FT.

VOR/DME
NOTO
111.45 NTE
CH-51Y
37°17'24"N/136°57'46"E
800FT

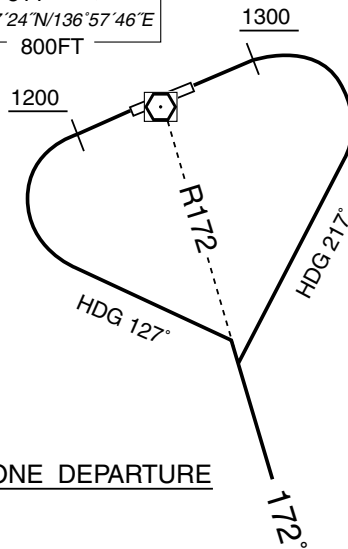

URUSI ONE DEPARTURE

△ URUSI R172/D29.4 NTE
8000

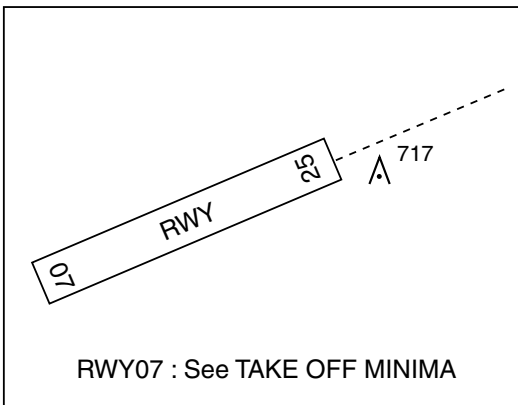

STANDARD ARRIVAL CHART -INSTRUMENT

RJNW / NOTO

STAR

GORYU ARRIVAL

From over HAPPO or GORYU, via TOE 43.1DME counterclockwise ARC to NOPPY or to intercept and proceed via NTE R074 to NTE VOR/DME.

Cross NOPPY at or above 3000FT, cross NTE VOR/DME at or above 3000FT.

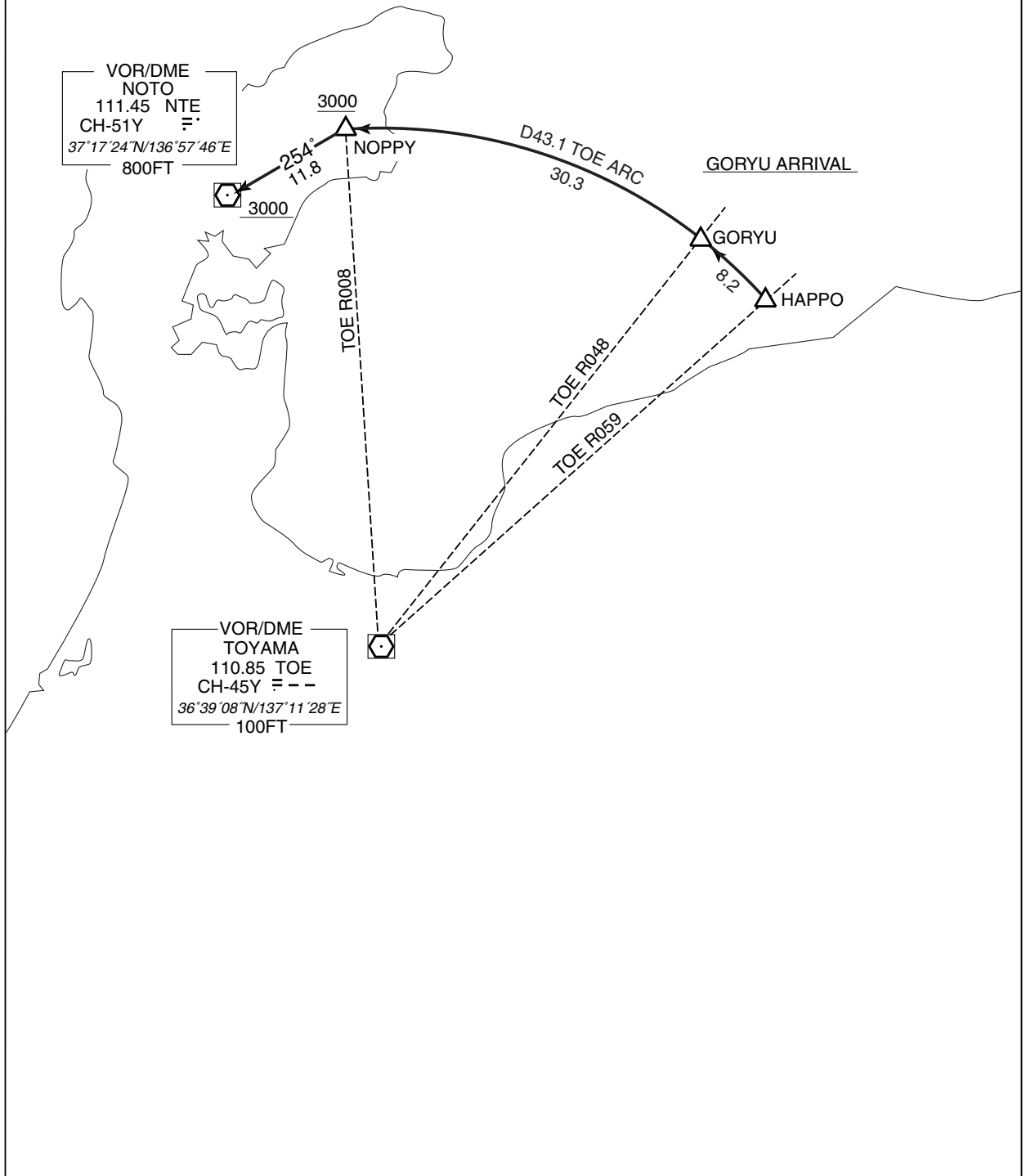

STANDARD ARRIVAL CHART -INSTRUMENT

RJNW / NOTO

RNAV STAR RWY07

KILCO ARRIVAL

RNP1

Note GNSS required.

VAR 8°W (2017)

VOR/DME
NOTO
111.45 NTE
CH-51Y
37°17'24"N/136°57'46"E
800FT

KILCO ARRIVAL

KILCO
370843.1N
1372519.8E
6000

HAPPO
370604.9N
1375320.7E

22.5
285°

CHANGE : Navigation Specification(Basic RNP1 → RNP1).

KILCO ARRIVAL

From HAPPO, to KILCO at or above 6000FT.

Serial Number	Path Descriptor	Waypoint Identifier	Fly Over	Course °M(°T)	Magnetic Variation	Distance (NM)	Turn Direction	Altitude (FT)	Speed (KIAS)	Vertical Angle	Navigation Specification
001	IF	HAPPO	-	-	-8.3	-	-	-	-	-	RNP1
002	TF	KILCO	-	285 (276.9)	-8.3	22.5	-	+6000	-	-	RNP1

INSTRUMENT APPROACH CHART

RJNW / NOTO

ILS Z or LOC Z RWY25

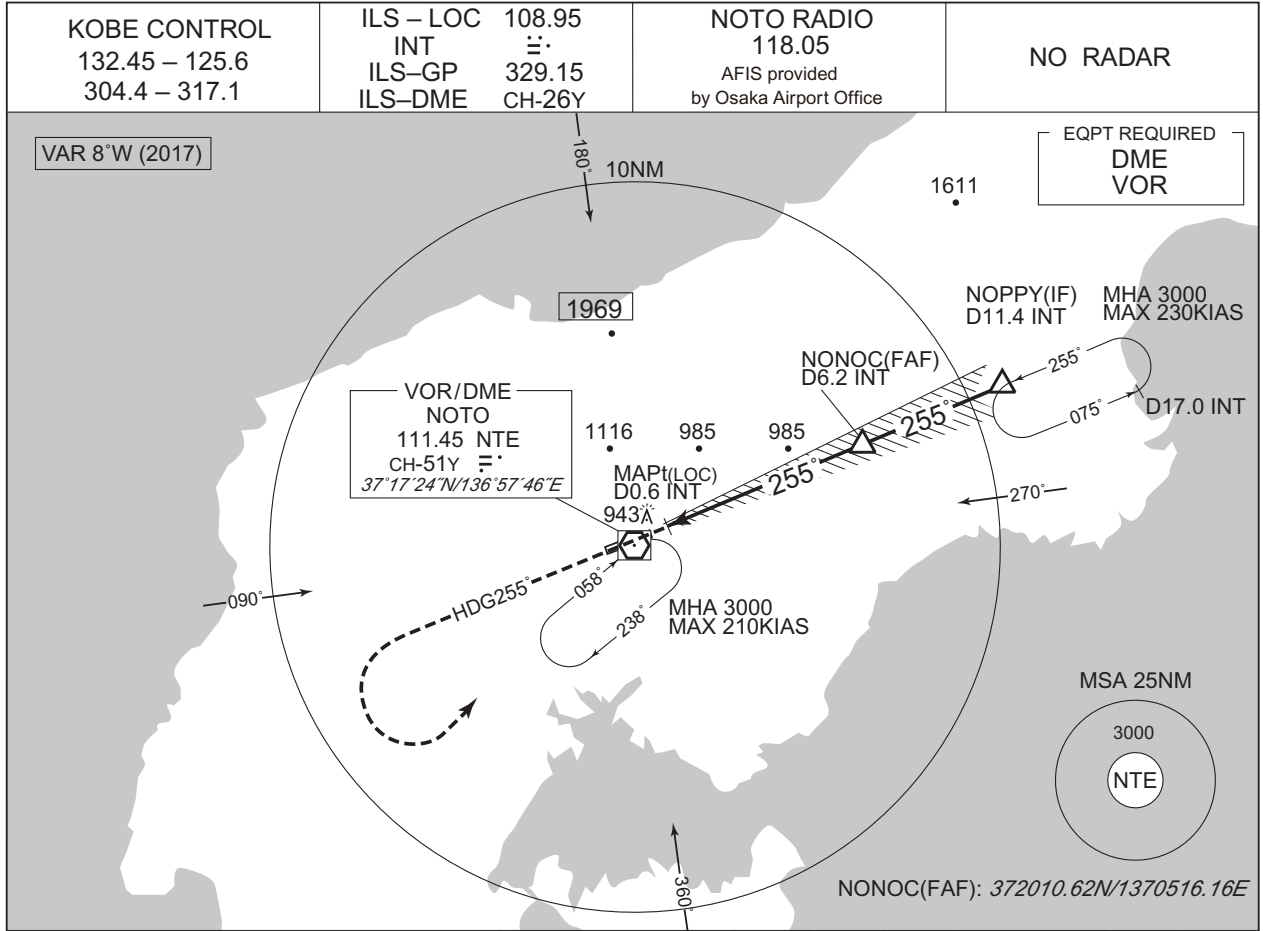

	NM to INT	MAPt	2	3	4	5	6	FAF
	ALT (3.0° APCH Path)	-	1336	1655	1974	2292	2611	2663

CHANGE : ATC call sign(TOKYO CONTROL → KOBE CONTROL).

MISSED APPROACH
Climb to 2000FT on HDG255°, turn left, direct to NTE VOR/DME and hold at 3000FT.
Contact NOTO RADIO.

Timing not authorized for defining the MAPt.

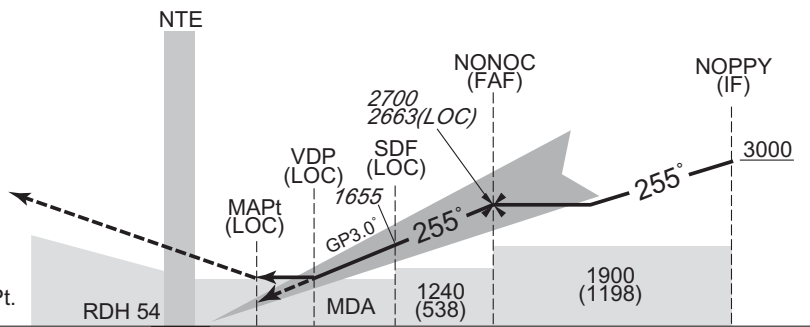

DME to INT	0.2	0.6	1.6	3.0	6.2	11.4
NM to THR	0	0.5	1.4	2.8	6.0	11.3

Missed APCH climb gradient MNM 5.0%

MINIMA		THR elev. 702	AD elev. 718			
CAT	CAT I		LOC		CIRCLING	
	DA(H)	RVR/CMV	MDA(H)	RVR/CMV	MDA(H)	VIS
A	902 (200)	550	1170 (468)	1000	1260 (542)	1600
B				1200		
C				1280 (562)	2400	
D				1600	1420 (702)	3200

MINIMA with Missed APCH climb gradient of 2.5% are not established.

INSTRUMENT APPROACH CHART

RJNW / NOTO

ILS Y or LOC Y RWY25

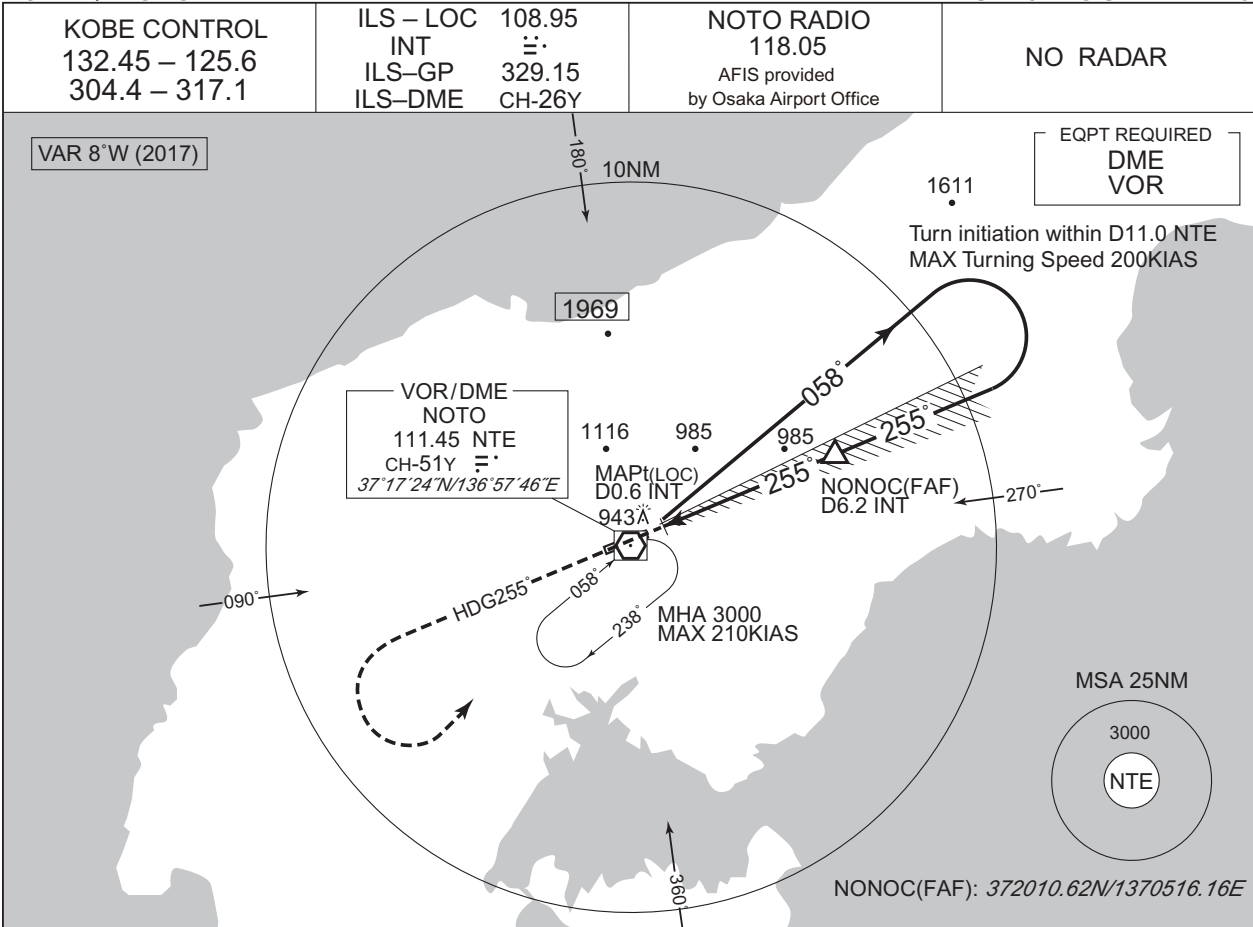

NM to INT	MAPt	2	3	4	5	6	FAF
ALT (3.0° APCH Path)	-	1336	1655	1974	2292	2611	2663

MISSED APPROACH

Climb to 2000FT on HDG255°, turn left, direct to NTE VOR/DME and hold at 3000FT. Contact NOTO RADIO.

Timing not authorized for defining the MAPt.

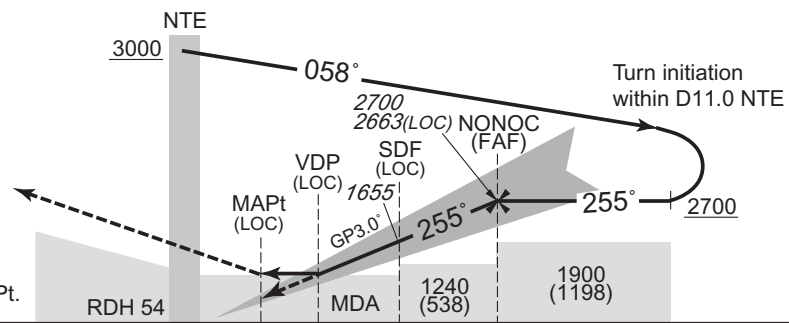

DME to INT	0.2	0.6	1.6	3.0	6.2
NM to THR	0	0.5	1.4	2.8	6.0

Missed APCH climb gradient MNM 5.0%

MINIMA		THR elev. 702		AD elev. 718		
CAT	CAT I		LOC		CIRCLING	
	DA(H)	RVR/CMV	MDA(H)	RVR/CMV	MDA(H)	VIS
A	902 (200)	550	1170 (468)	1000	1260 (542)	1600
B				1200		
C				1280 (562)	2400	
D				1600	1420 (702)	3200

MINIMA with Missed APCH climb gradient of 2.5% are not established.

CHANGE : ATC call sign(TOKYO CONTROL → KOBE CONTROL).

INSTRUMENT APPROACH CHART

RJNW / NOTO

VOR RWY25

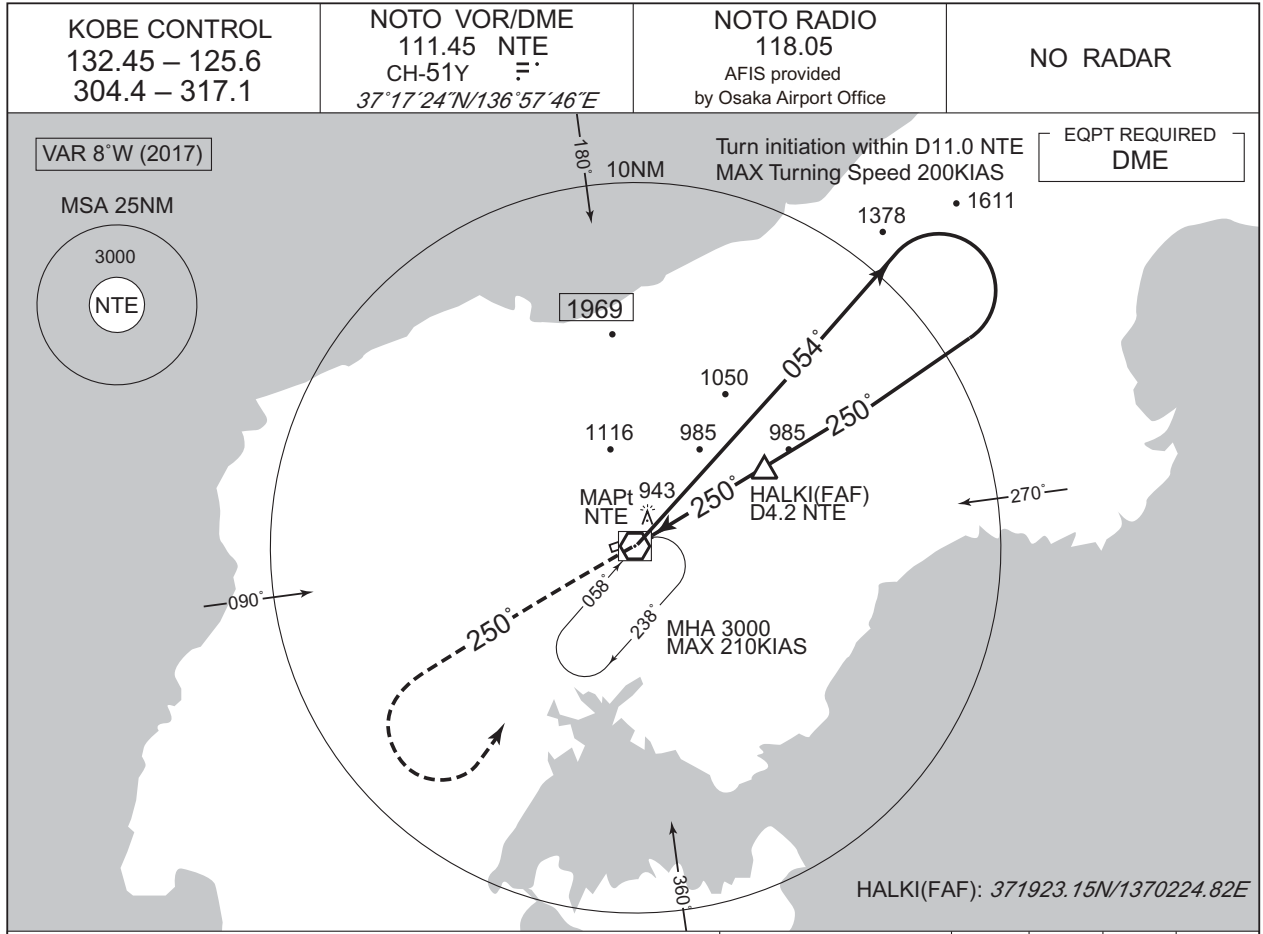

CHANGE : ATC call sign(TOKYO CONTROL → KOBE CONTROL).

	NM to NTE	MAPt	3	4	FAF
ALT (3.0° APCH Path)	-	1515	1834	1898	

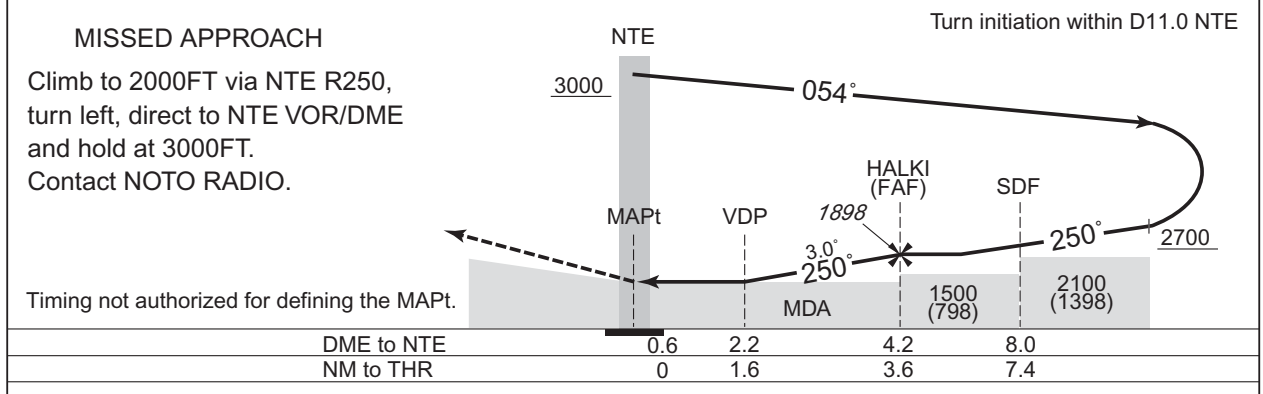

MINIMA		THR elev. 702	AD elev. 718	
CAT			CIRCLING	
	MDA(H)	RVR/CMV	MDA(H)	VIS
A	1240 (538)	1000	1260 (542)	1600
B		1200		
C		1200	1280 (562)	2400
D		1600	1420 (702)	3200

INSTRUMENT APPROACH CHART

RJNW / NOTO

VOR RWY07

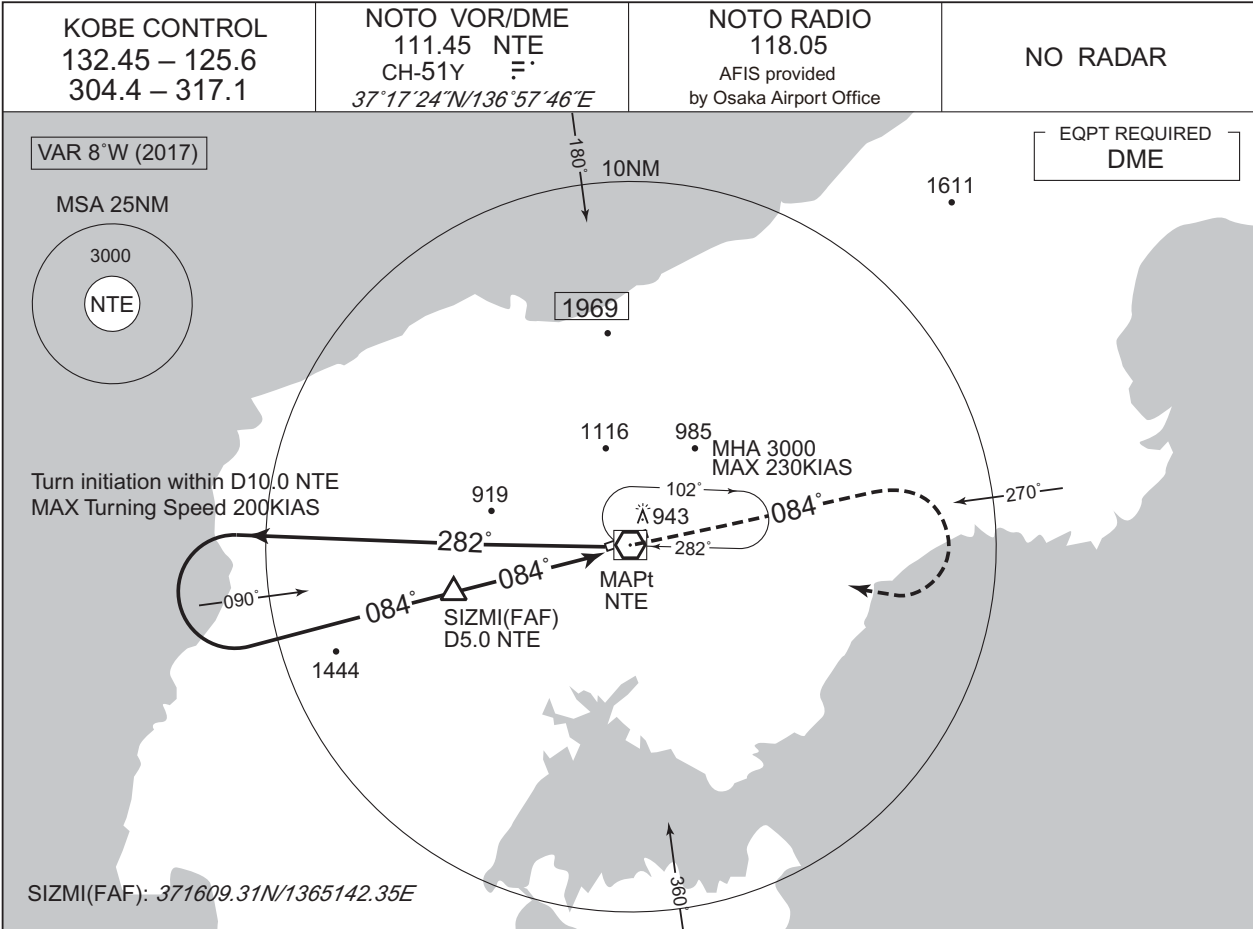

NM to NTE	FAF	4	3	2	MAPt
ALT (3.0° APCH Path)	2188	1870	1552	1233	-

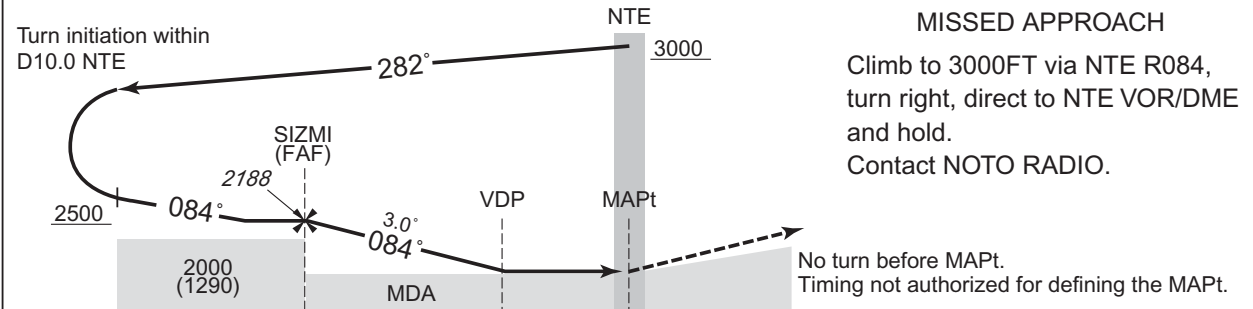

DME to NTE	5.0	1.7	0.5
NM to THR	4.5	1.2	0

MINIMA		THR elev. 710		AD elev. 718	
CAT	MDA(H)		CIRCLING		
	MDA(H)	CMV	MDA(H)	VIS	
A	1140 (430)	1200	1260 (542)	1600	
B		1300			
C		1400	1280 (562)	2400	
D		1600	1420 (702)	3200	

CHANGE : ATC call sign(TOKYO CONTROL → KOBE CONTROL).

INSTRUMENT APPROACH CHART

RJNW / NOTO RNP Z RWY07(AR)

KOBE CONTROL 132.45 - 125.6 304.4 - 317.1	RNP AR RF required.	NOTO RADIO 118.05 AFIS provided by Osaka Airport Office	NO RADAR
--	-------------------------------	---	-----------------

For uncompensated Baro-VNAV systems, procedure not authorized below -10°C / above 45°C

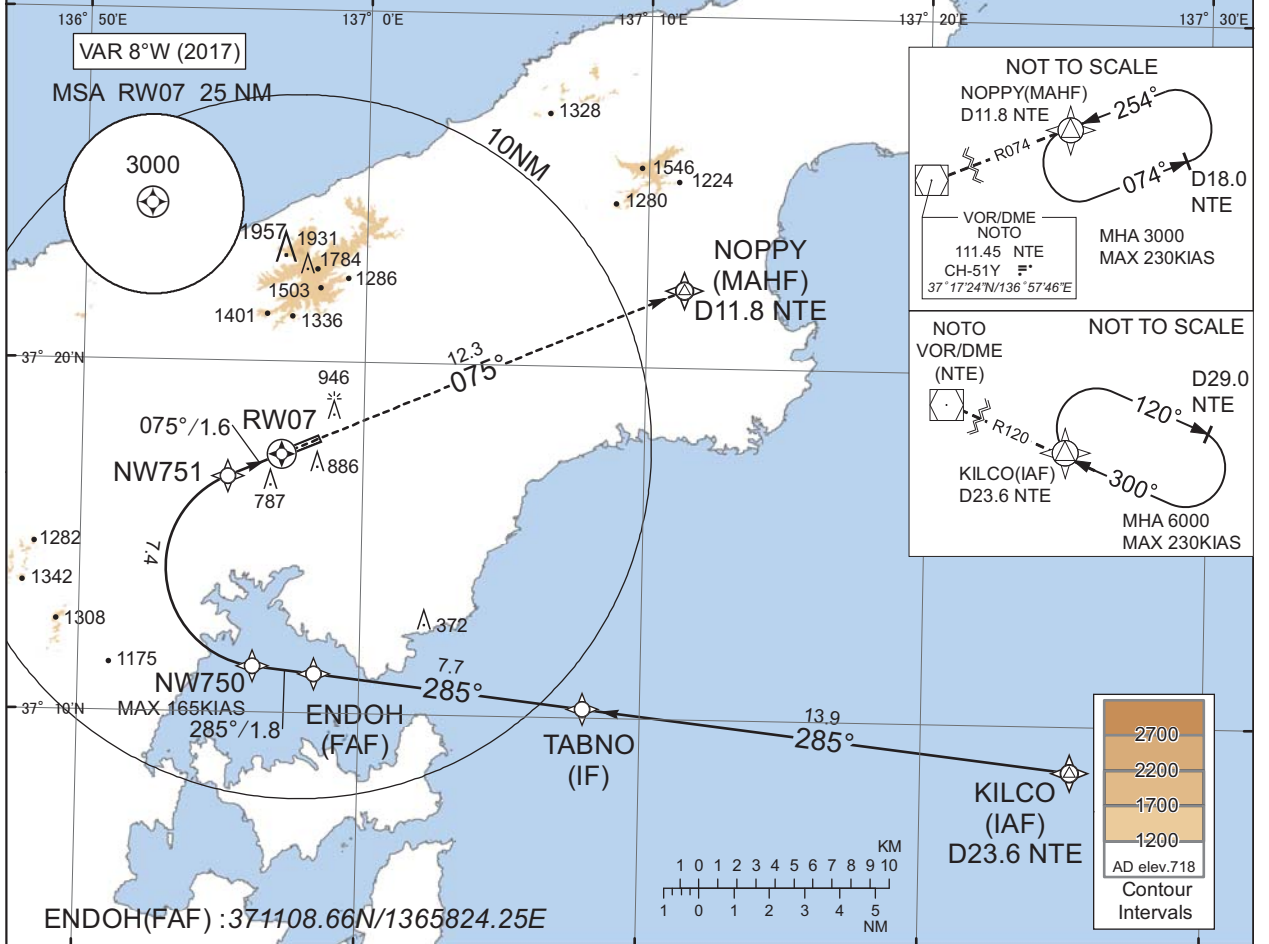

CHANGE : ATC call sign (TOKYO CONTROL → KOBE CONTROL).

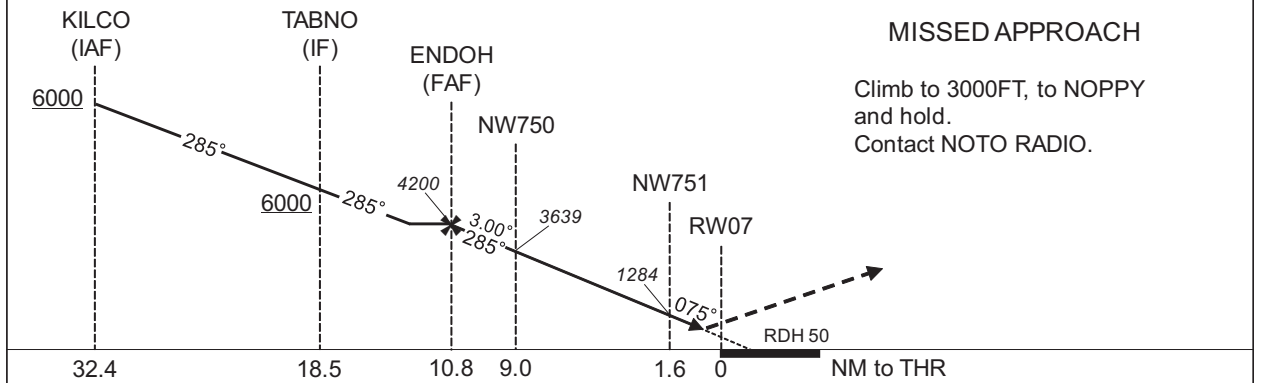

Missed APCH climb gradient MNM 3.2%

	MINIMA	THR elev. 710	AD elev. 718
CAT	RNP 0.30		
	DA(H)		
A	-		
B	-		
C	1010(300)	1400	
D	1010(300)	1600	

Authorization Required

MINIMA with Missed APCH climb gradient of 2.5% are not established.

INSTRUMENT APPROACH CHART

RJNW / NOTO

RNP Z RWY07(AR)

Coding Table

Serial Number	Path Descriptor	Waypoint Identifier	Fly Over	Course °M(°T)	Magnetic Variation	Distance (NM)	Turn Direction	Altitude (FT)	Speed (KIAS)	VPA/RDH (°/FT)	RNP Value
001	IF	KILCO	-	-	-8.3	-	-	+6000	-	-	-
002	TF	TABNO	-	285 (276.6)	-8.3	13.9	-	+6000	-	-	1.0
003	TF	ENDOH	-	285 (276.4)	-8.3	7.7	-	4200	-	-	1.0
004	TF	NW750	-	285 (276.3)	-8.3	1.8	-	3639	-165	-3.00	0.3
005	RF Center: NWRF1 r=2.82NM	NW751	-	-	-8.3	7.4	R	1284	-	-3.00	0.3
006	TF	RW07	Y	075 (066.6)	-8.3	1.6	-	760	-	-3.00/50	0.3
007	TF	NOPPY	-	075 (066.7)	-8.3	12.3	-	3000	-	-	1.0

Waypoint Coordinates

Waypoint Identifier	Coordinates	RF Arc Center Identifier	Coordinates
KILCO	370843.05N / 1372519.77E	NWRF1	371408.38N / 1365636.03E
TABNO	371017.61N / 1370758.59E		
ENDOH	371108.66N / 1365824.25E		
NW750	371120.22N / 1365612.92E		
NW751	371643.80N / 1365512.45E		
RW07	371722.92N / 1365706.38E		
NOPPY	372214.69N / 1371120.01E		

CHANGE : PROC renamed.

INSTRUMENT APPROACH CHART

RJNW / NOTO RNP Y RWY07(AR)

KOBE CONTROL 132.45 - 125.6 304.4 - 317.1	RNP AR RF required.	NOTO RADIO 118.05 AFIS provided by Osaka Airport Office	NO RADAR
---	------------------------	--	----------

For uncompensated Baro-VNAV systems, procedure not authorized below -10°C / above 45°C

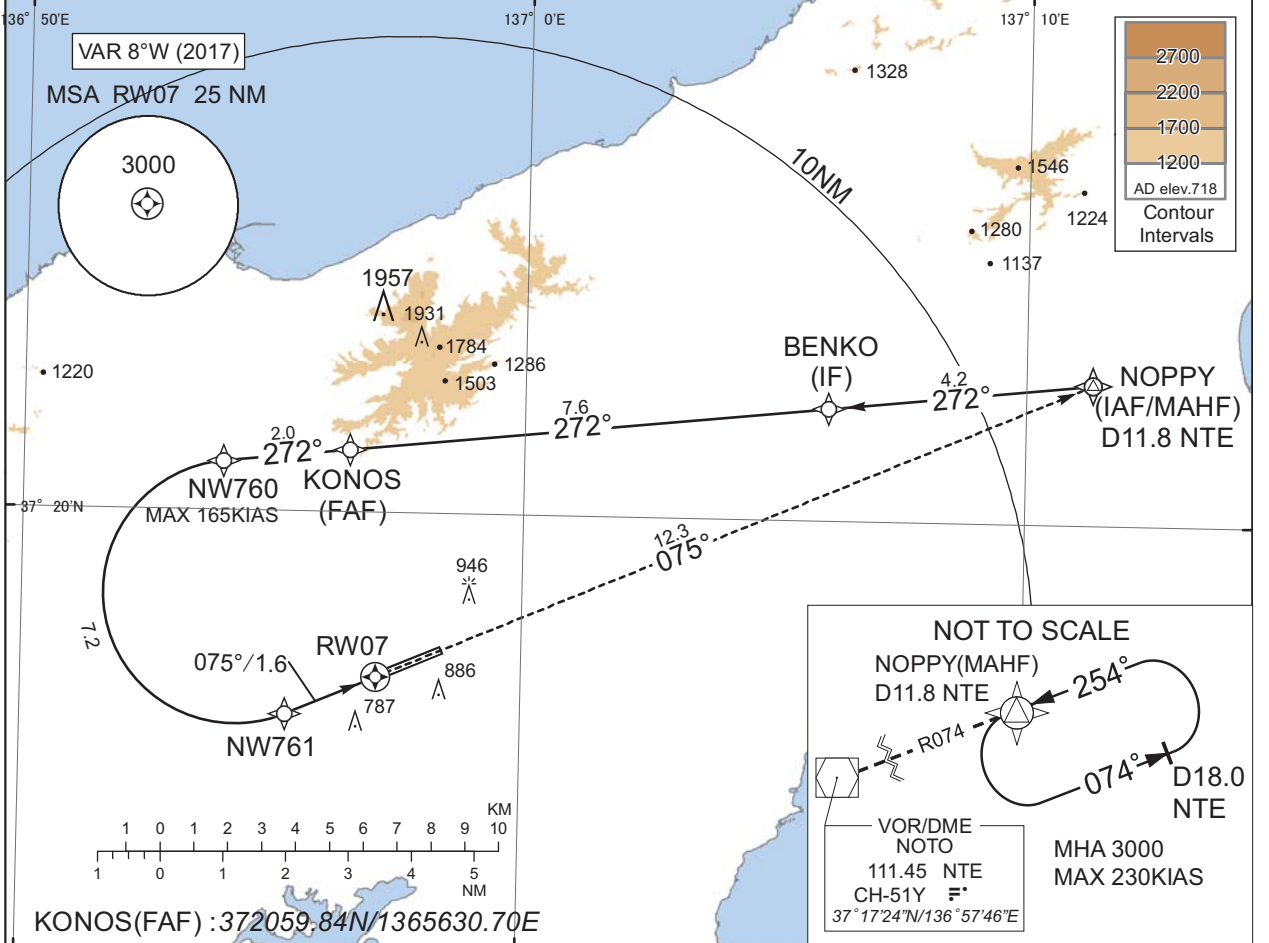

CHANGE : ATC call sign (TOKYO CONTROL → KOBE CONTROL).

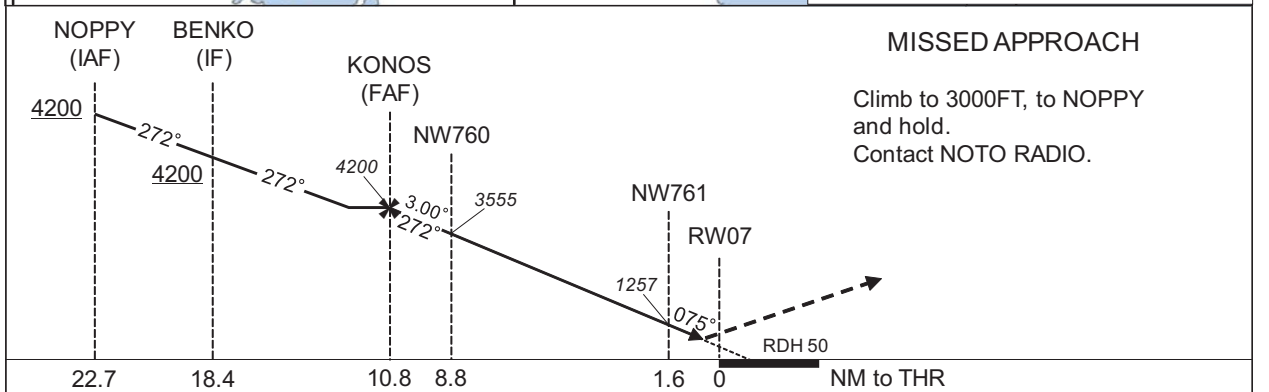

Misssed APCH climb gradient MNM 3.2%

MINIMA	THR elev. 710	AD elev. 718
CAT	RNP 0.30	
	DA(H)	CMV
A	-	-
B	-	-
C	1010(300)	1400
D	-	1600

Authorization Required

MINIMA with Missed APCH climb gradient of 2.5% are not established.

INSTRUMENT APPROACH CHART

RJNW / NOTO

RNP Y RWY07(AR)

Coding Table

Serial Number	Path Descriptor	Waypoint Identifier	Fly Over	Course °M(°T)	Magnetic Variation	Distance (NM)	Turn Direction	Altitude (FT)	Speed (KIAS)	VPA/RDH (°/FT)	RNP Value
001	IF	NOPPY	-	-	-8.3	-	-	+4200	-	-	-
002	TF	BENKO	-	272 (264.0)	-8.3	4.2	-	+4200	-	-	1.0
003	TF	KONOS	-	272 (264.0)	-8.3	7.6	-	4200	-	-	1.0
004	TF	NW760	-	272 (263.9)	-8.3	2.0	-	3555	-165	-3.00	0.3
005	RF Center: NWRF2 r=2.10NM	NW761	-	-	-8.3	7.2	L	1257	-	-3.00	0.3
006	TF	RW07	Y	075 (066.6)	-8.3	1.6	-	760	-	-3.00/50	0.3
007	TF	NOPPY	-	075 (066.7)	-8.3	12.3	-	3000	-	-	1.0

Waypoint Coordinates

Waypoint Identifier	Coordinates	RF Arc Center Identifier	Coordinates
NOPPY	372214.69N / 1371120.01E	NWRF2	371841.62N / 1365416.12E
BENKO	372148.26N / 1370603.41E		
KONOS	372059.84N / 1365630.70E		
NW760	372046.91N / 1365359.30E		
NW761	371645.85N / 1365518.43E		
RW07	371722.92N / 1365706.38E		
NOPPY	372214.69N / 1371120.01E		

CHANGE : PROC renamed.

RJNW / NOTO

Visual REP

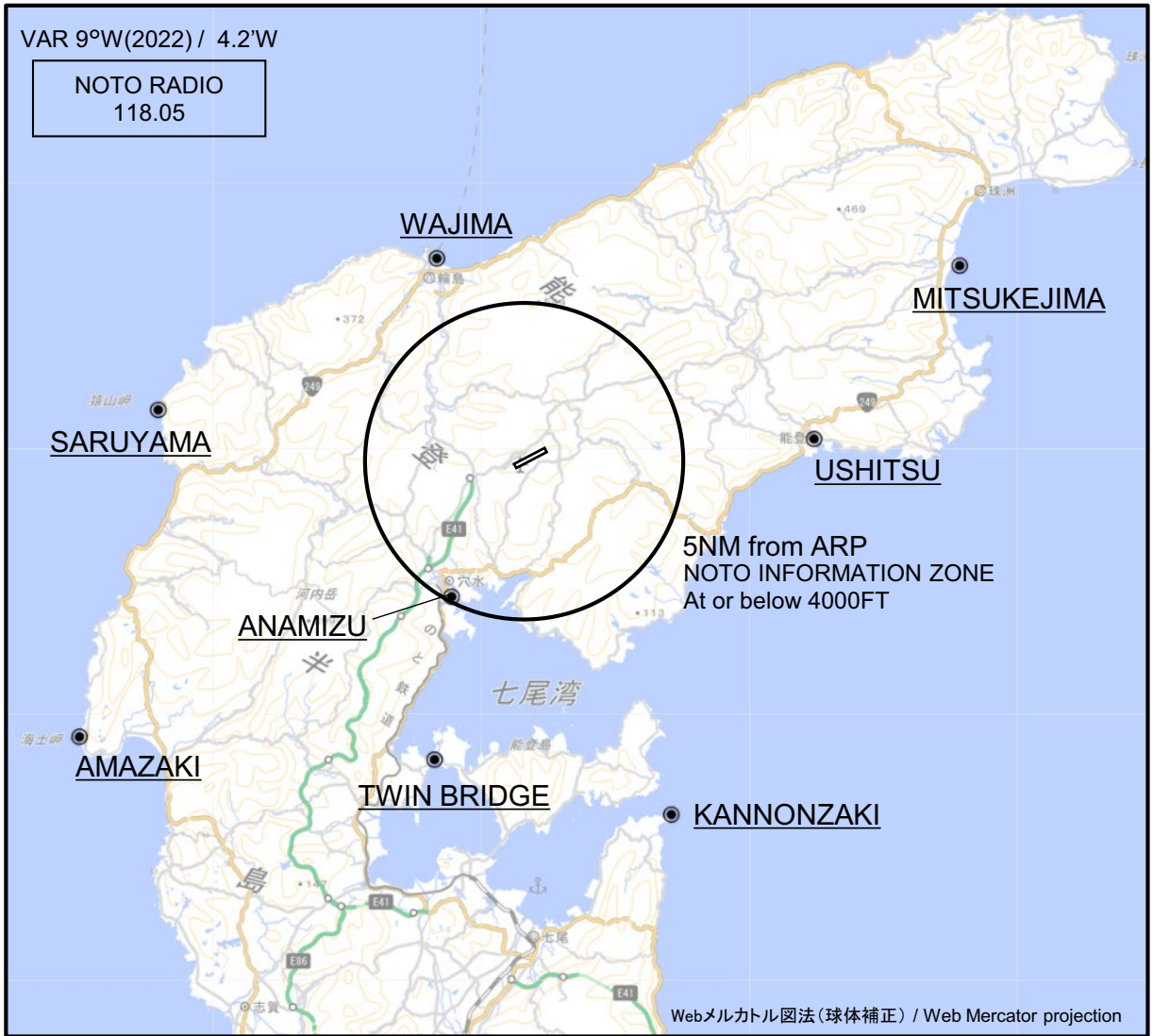

※図中に標高を示す数字がある場合、単位はメートル(m)である。The unit of measurement used to express elevation is meter(m).

CHANGE : VAR.

Call sign	BRG / DIST from ARP	Remarks
見附島 Mitsukejima	066°T / 14.9NM	島 Island
宇出津 Ushitsu	085°T / 9.1NM	港 Harbor
観音崎 Kannonzaki	158°T / 12.0NM	岬 Cape
ツインブリッジ TwinBridge	197°T / 9.8NM	橋 Bridge
穴水 Anamizu	210°T / 4.6NM	港 Harbor
海士崎 Amazaki	238°T / 16.5NM	岬 Cape
猿山 Saruyama	278°T / 11.7NM	岬 Cape
輪島 Wajima	335°T / 7.0NM	港 Harbor

RJNW / NOTO

Minimum Vectoring Altitude CHART

