

AD 2 AERODROMES

RJOR AD 2.1 AERODROME LOCATION INDICATOR AND NAME

RJOR - TOTTORI

RJOR AD 2.2 AERODROME GEOGRAPHICAL AND ADMINISTRATIVE DATA

1	ARP coordinates and site at AD	353148N 1340954E 1.06km FM RWY 10 THR
2	Direction and distance from (city)	5km NW from Tottori City
3	Elevation/ Reference temperature	48ft / 30°C(2003-2008)
4	Geoid undulation at AD ELEV PSN	117ft
5	MAG VAR/ Annual change	8°W(2014) / 1°W
6	AD Administration, address, telephone, telefax, telex, AFS, e-mail and/or Web-site addresses	Tottori Airport Building Co., Ltd 4-110-5 koyama-cho Tottori-shi 680-0947 Japan Tel 0857-28-1150 Fax 0857-28-4244 e-mail : kukokanribu@tj-ap-bld.co.jp
7	Types of traffic permitted(IFR/VFR)	IFR/VFR
8	Remarks	Nil

RJOR AD 2.3 OPERATIONAL HOURS

1	AD Administration	2200 - 1230
2	Customs and immigration	On request Customs: 0859-42-2228 Immigration: 0859-47-3600
3	Health and sanitation	On request Quarantine(human): 0859-42-3517 Quarantine(animal): 0859-45-3800 Quarantine(plant): 0859-42-2513
4	AIS Briefing Office	Nil
5	ATS Reporting Office(ARO)	Nil
6	MET Briefing Office	H24 (KANSAI)
7	ATS	2200 - 1230 Remarks : AFIS provided by Osaka Airport Office.
8	Fuelling	2100 - 1000
9	Handling	2100 - 1230
10	Security	2100 - 0930
11	De-icing	2100 - 1230
12	Remarks	Nil

RJOR AD 2.4 HANDLING SERVICES AND FACILITIES

1	Cargo-handling facilities	Container LD3 , LD4 , LD3`45
2	Fuel/ oil types	JET A-1
3	Fuelling facilities/ capacity	Fuel Truck X 2 / 1200L X 2
4	De-icing facilities	Nil
5	Hangar space for visiting aircraft	Nil
6	Repair facilities for visiting aircraft	Nil
7	Remarks	Nil

RJOR AD 2.5 PASSENGER FACILITIES

1	Hotels	In Tottori city
2	Restaurants	At airport
3	Transportation	Bus and taxi
4	Medical facilities	Hospital in Tottori city 1km
5	Bank and Post Office	Nil(Cash dispenser at airport)
6	Tourist Office	Nil
7	Remarks	Information counter in airport

RJOR AD 2.6 RESCUE AND FIRE FIGHTING SERVICES

1	AD category for fire fighting	CAT 8
2	Rescue equipment	Chemical fire fighting truck x 3 , Emergency medical equipments conveyance truck
3	Capability for removal of disabled aircraft	Ask AD Administration
4	Remarks	Nil

RJOR AD 2.7 SEASONAL AVAILABILITY-CLEARING

1	Types of clearing equipment	Snow removal equipments : motor graders x 16
2	Clearance priorities	1.RWY , West TWY , West APRON 2.East TWY , East APRON Small APRON
3	Remarks	Seasonal availability: All seasons Snow removal will be commenced,if the RWY and TWY are covered with snow. TWY/APN to measure the coefficient of friction: Nil

RJOR AD 2.8 APRONS, TAXIWAYS AND CHECK LOCATIONS DATA

1	Apron surface and strength	West APRON Surface :Concrete, Strength : PCN53/R/C/X/T Small APRON Surface : Asphalt, Strength : AUW5700kg / 0.28MPa East APRON Surface : Concrete and Asphalt, Strength : AUW5700kg/0.28MPa
2	Taxiway width, surface and strength	WEST TWY Width : 30m, Surface : Asphalt, Strength : PCN48/F/B/X/T EAST TWY Width : 8m, Surface : Concrete and Asphalt, Strength : AUW 5700kg/0.28Mpa
3	ACL and elevation	Not available
4	VOR checkpoints	Not Available
5	INS checkpoints	Spot Nr 1 353137.44N 1341001.55E 2 353137.29N 1341003.89E 3 353137.17N 1341006.26E
6	Remarks	Nil

RJOR AD 2.9 SURFACE MOVEMENT GUIDANCE AND CONTROL SYSTEM AND MARKINGS

1	Use of aircraft stand ID signs, TWY guide lines and Visual docking/ parking guidance system of aircraft stands	Nil
2	RWY and TWY markings and LGT	RWY:10/28 (Marking) RWY designation, RWY CL, RWY THR, Aiming point, TDZ, RWY side stripe ,RWY turn pad edge, RWY turn pad CL, RWY middle point (LGT) RCLL, REDL, RTHL, RTZL(RWY10), WBAR(RWY10), Turning point indicator LGT, RWY DIST marker LGT ALL TWY: (Marking) TWY CL, RWY HLDG PSN, TWY side stripe (LGT) TWY edge LGT West TWY: (Marking) Mandatory instruction (LGT) TWY CL LGT
3	Stop bars	Nil
4	Remarks	(Marking) Overrun area (LGT) Apron flood LGT

180Turn on RWY

B-767型機用の滑走路180° 旋回用標識及び実施要領

1. 滑走路中心線からターニングパッド中心線標識に従って進行する。
2. 転回灯1が一直線に見えるように進行し、転回灯2が一直線に見えた時転回を開始する。転回時はMAX STEERING ANGLEを使用する。

Markings for 180° turn on RWY of B-767 aircraft and Procedure using the Marking

1. Proceed along the RWY Turn Pad Center Line Marking.
2. Proceed along the RWY Turn Pad Center Line Marking to see the Turning Point Indicator Light 1 on a straight line, then commence turn at the spot where you (pilot) can see the Turning Point Indicator Light 2 on a straight line at an angle of 9 o'clock. When turning, take MAX STEERING ANGLE.

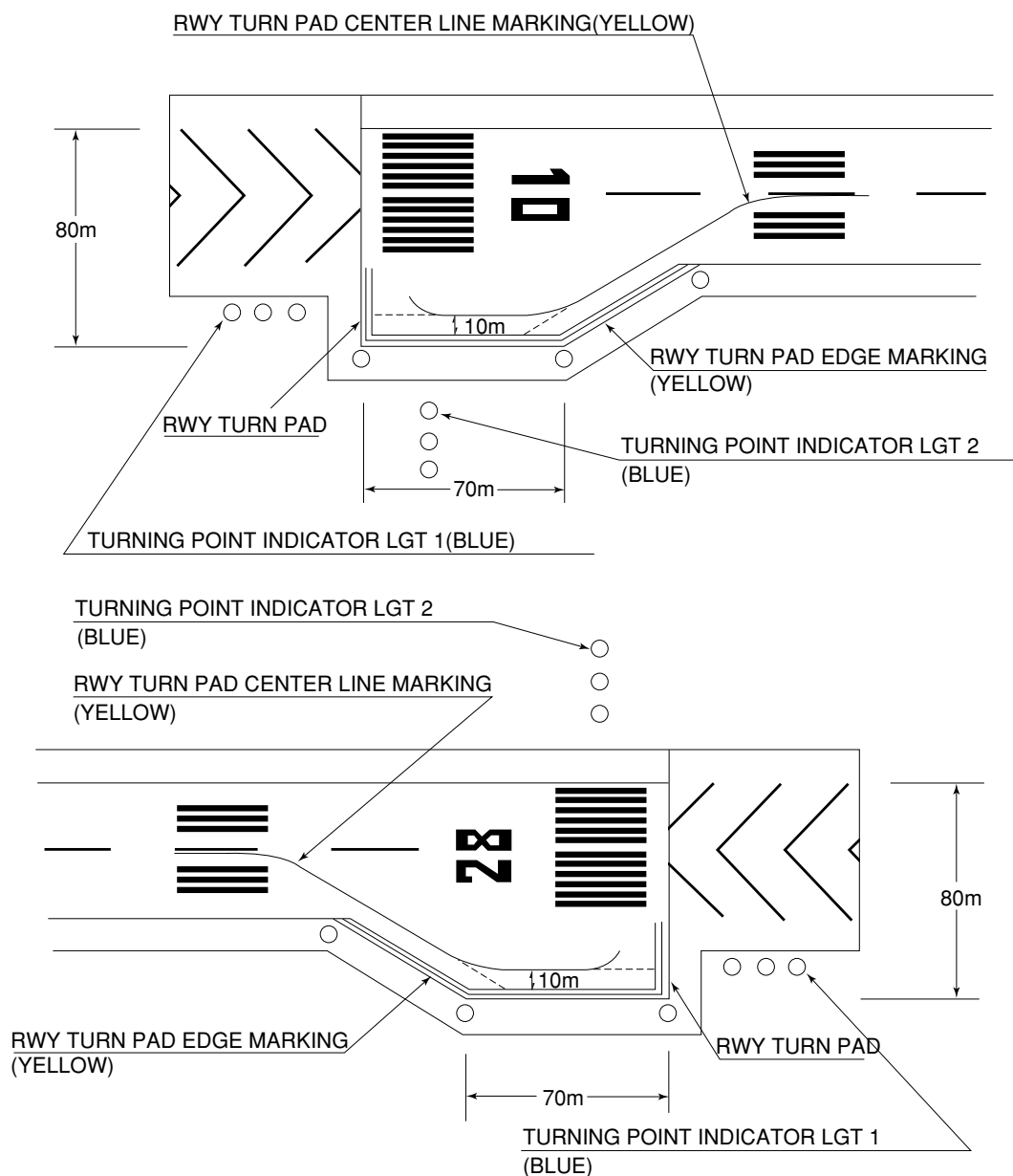

RJOR AD 2.10 AERODROME OBSTACLES

In Area2 See Obstacle data

In Area3 To be developed

RJOR AD 2.11 METEOROLOGICAL INFORMATION PROVIDED

1	Associated MET Office	KANSAI
2	Hours of service MET Office outside hours	H24 (KANSAI)
3	Office responsible for TAF preparation Periods of validity	Nil
4	Trend forecast Interval of issuance	Nil
5	Briefing/ consultation provided	Briefing is available upon inquiry at KANSAI
6	Flight documentation Language(s) used	C, En
7	Charts and other information available for briefing or consultation	S ₆ , U ₈₅ , U ₇ , U ₅ , U ₃ , U ₂₅ , U ₂ /T _r , P _S , P ₅ , P ₃ , P ₂₅ , P _{SWE} , P _{SWF} , P _{SWG} , P _{SWI} , P _{SWM} , P _{SW} (domestic), E, C, W _E , W _F , W _G , W _I , W, N
8	Supplementary equipment available for providing information	Nil
9	ATS units provided with information	RADIO
10	Additional information (limitation of service, etc.)	Nil

RJOR AD 2.12 RUNWAY PHYSICAL CHARACTERISTICS

Designations RWY NR	TRUE BRG	Dimensions of RWY(M)	Strength(PCN) and surface of RWY	THR coordinates THR geoid undulation	THR elevation and highest elevation of TDZ of precision APP RWY
1	2	3	4	5	6
10	093.78°	2000x45	PCN 48/F/B/X/T Asphalt-Concrete	353150.32N 1340914.57E 117.1ft	THR ELEV: 28.9ft TDZ ELEV: 46.6ft
28	273.78°	2000x45	PCN 48/F/B/X/T Asphalt-Concrete	353146.03N 1341033.79E 117.3ft	THR ELEV: 64.6ft
Slope of RWY	Strip Dimensions(M)	RESA(Overrun) Dimensions(M)	Remarks		
7	10	11	14		
See AD2.24 AD chart	2120x300	175x(MNM:146 MAX:298)*	41x(MNM:291 MAX:300)* *For detail, ask airport administrator	RWY Grooving: 2000x30m	

RJOR AD 2.13 DECLARED DISTANCES

RWY Designator	TORA (m)	TODA (m)	ASDA (m)	LDA (m)	Remarks
1	2	3	4	5	6
10	2000	2000	2000	2000	Nil
28	2000	2000	2000	2000	Nil

RJOR AD 2.14 APPROACH AND RUNWAY LIGHTING

RWY Designator	APCH LGT type LEN INTST	RTHL Color WBAR	PAPI (VASIS) Angle DIST FM THR MEHT	RTZL LEN	RCLL LEN Spacing Color INTST	REDL LEN Spacing Color INTST	RENL Color WBAR	STWL LEN Color
1	2	3	4	5	6	7	8	9
10	PALS (CAT I) 899m LIH	Green Green	PAPI 3.0°/Left 336.2m 61ft	900m	2000m 30m Coded color (White/Red) LIH	2000m 60m Coded color (White/Yellow) LIH	Red	Nil (*3)
28	SALS (*1) 418m LIH	Green -	PAPI(*2) 3.0°/Left 416.0m 61ft	-	2000m 30m Coded color (White/Red) LIH	2000m 60m Coded color (White/Yellow) LIH	Red	Nil (*3)
Remarks								
10								
SALS with APCH LGT beacon (593m and 888m FM RWY THR) (*1) Usable area : Within 3.1NM FM RWY 28 THR(*2)(See attached) Overrun area edge LGT(LEN60m color:Red) (*3) CGL for RWY28								

滑走路28末端側進入角指示灯の使用制限は、障害物（山）のため滑走路28末端から約3.1NM以内とする。下図のとおり。

Usable area of PAPI for runway 28 is within approx. 3.1NM from runway 28 threshold due to obstruction (mountain).

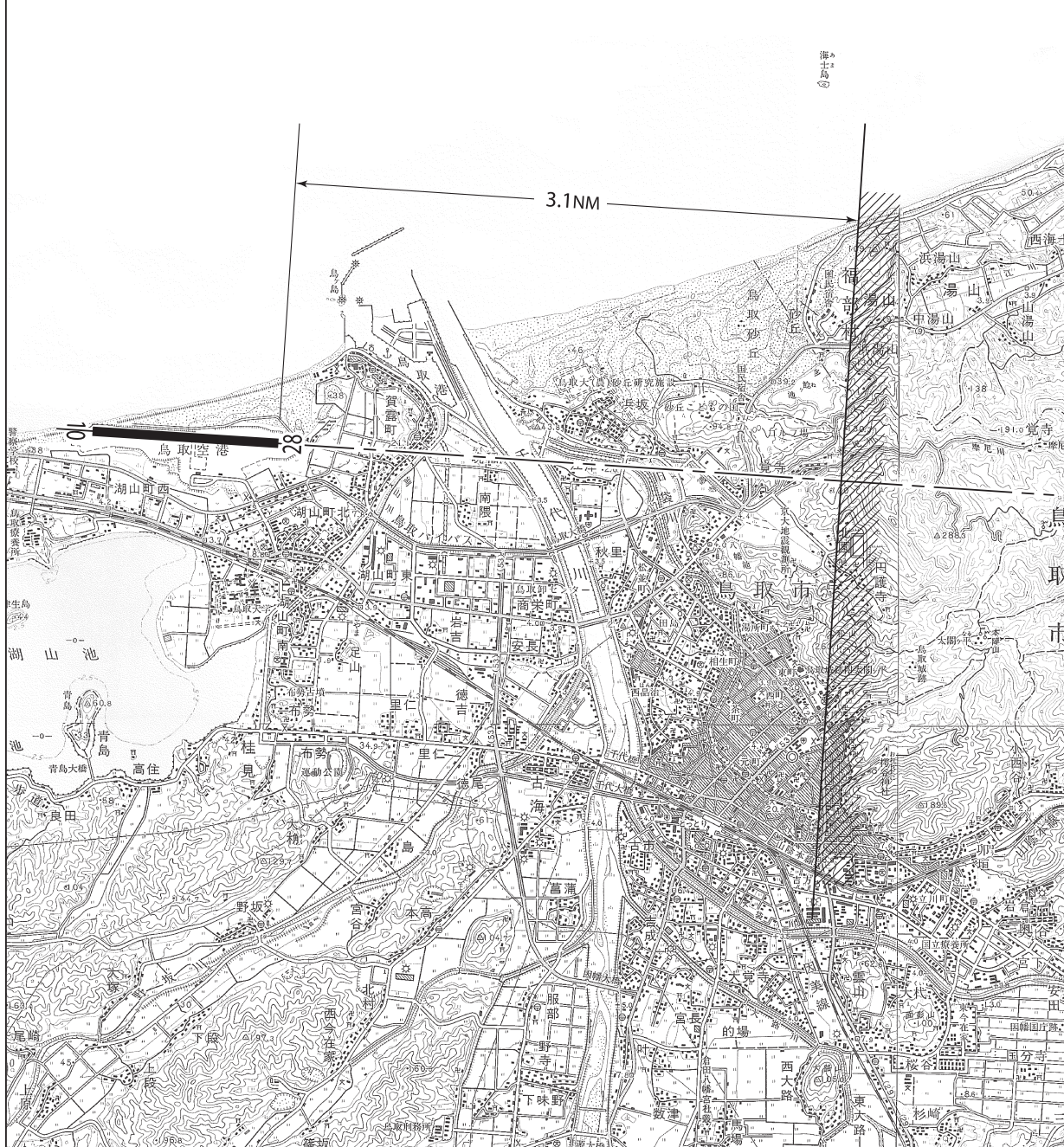

RJOR AD 2.15 OTHER LIGHTING, SECONDARY POWER SUPPLY

1	ABN/IBN location, characteristics and hours of operation	ABN: 353131N/1341002E, White/Green EV4.3sec, HO
2	LDI location and LGT Anemometer location and LGT	LDI:Nil Anemometer: 300m FM RWY10/28 THR, LGTD
3	TWY edge and centerline lighting	TWY edge and center line lights installed, see AD2.9
4	Secondary power supply/ switch-over time	Within 1sec : REDL, RTHL, RENL, WBAR, RCLL, Overrun area edge LGT, Turning point indicator LGT Within 15sec : Other LGT
5	Remarks	WDI LGT

RJOR AD 2.16 HELICOPTER LANDING AREA

Nil

RJOR AD 2.17 ATS AIRSPACE

Designation and lateral limits		Vertical limits (ft)	Airspace classification	ATS unit call sign Language	Remarks
1		2	3	4	6
Tottori Information Zone	Area within a radius of 5nm(9km) of Tottori ARP	3,000 or below	E	Tottori Radio En	

RJOR AD 2.18 ATS COMMUNICATION FACILITIES

Service designation	Call sign	Frequency	Hours of operation	Remarks
1	2	3	4	5
AFIS	Tottori Radio	118.15MHz	2200 - 1230	Operated by Osaka Airport Office

RJOR AD 2.19 RADIO NAVIGATION AND LANDING AIDS

Type of aid (VOR declination)	ID	Frequency	Hours of operation	Position of transmitting antenna coordinates	Elevation of DME transmitting antenna	Remarks
1	2	3	4	5	6	7
VOR (8°W/2013)	TRE	110.2MHz	H24	353138.28N 1340953.59E		VOR Unusable: 080°-100° beyond 35NM BLW 5000ft. 110°-120° beyond 30NM BLW 7000ft. 120°-150° beyond 35NM BLW 7000ft. 150°-160° beyond 30NM BLW 7000ft. 180°-200° beyond 35NM BLW 7000ft. 200°-210° beyond 30NM BLW 7000ft. 210°-230° beyond 25NM BLW 7000ft. 230°-240° beyond 30NM BLW 7000ft.
DME	TRE	1000MHz (CH-39X)	H24	353138.28N 1340953.59E	115ft	DME Unusable: 120°-130° beyond 35NM BLW 7000ft. 190°-220° beyond 35NM BLW 7000ft. 220°-230° beyond 30NM BLW 7000ft. 230°-240° beyond 35NM BLW 7000ft.
ILS-LOC 10	ITR	111.5MHz	2200 - 1230	353145.52N 1341043.09E		LOC:235m(771ft)away FM RWY 28 THR, BRG(MAG) 101°
ILS-DME 10	ITR	1013MHz (CH-52X)	2200 - 1230	353145.52N 1340925.24E	51ft	DME:278m(912ft)inside FM RWY 10 THR, 130m (426ft) S of RCL.
ILS-GP 10	-	332.9MHz	2200 - 1230	353145.62N 1340925.22E		GP:278m(912ft)inside FM RWY 10 THR, 126.5m(415ft) S of RCL. GP angle3.0°. ILS Ref datum 16.5m (54ft).

TOTTORI AIRPORT

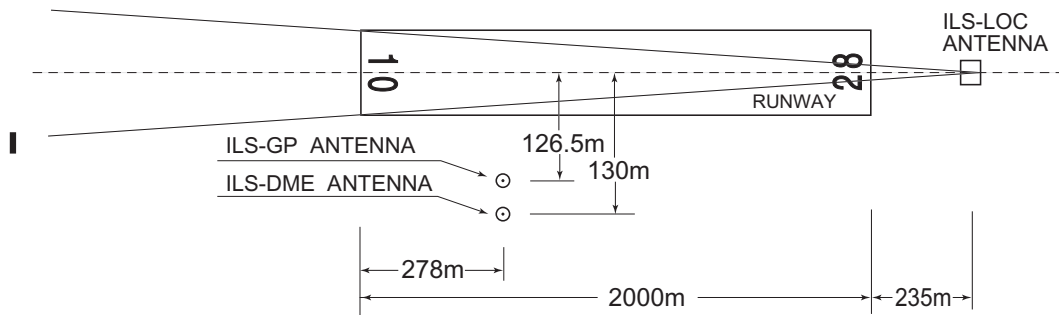

- REMARKS :
- 1. LOC beam BRG(MAG) 101°
 - 2. HGT of ILS REF datum 16.5m(54ft)
 - 3. GP Angle 3.0°
 - 4. ELEV of ILS-DME 15.4m(51ft)

RJOR AD 2.20 LOCAL TRAFFIC REGULATIONS

1. Airport regulations

Nil

2. Taxiing to and from stands

Nil

3. Parking area for small aircraft(General aviation)

AD administration restricted to taxi into and out of small apron after sunset due to no lighting facility.

4. Parking area for helicopters

AD administration restricted to taxi into and out of small apron after sunset due to no lighting facility.

5. Apron - taxiing during winter conditions

Nil

6. Taxiing - limitations

Nil

7. School and training flights - technical test flights - use of runways

Nil

8. Helicopter traffic - limitation

Nil

9. Removal of disabled aircraft from runways

Nil

RJOR AD 2.21 NOISE ABATEMENT PROCEDURES

Nil

RJOR AD 2.22 FLIGHT PROCEDURES

TAKE OFF MINIMA

	RWY	ACFT CAT	REDL & RCLL		REDL or RCLL or RCL Marking		NIL (DAYTIME ONLY)	
			RVR	VIS	RVR	VIS	RVR	VIS
Multi-Engine ACFT with TKOF ALTN AP Filed	10	A,B,C,D	400m	400m	400m	400m	-	500m
	28	A,B,C,D	-	400m	-	400m	-	500m
OTHER	10	A,B,C,D	AVBL LDG MINIMA					
	28							

RJOR AD 2.23 ADDITIONAL INFORMATION

Nil

RJOR AD 2.24 CHARTS RELATED TO AN AERODROME

<ul style="list-style-type: none"> Aerodrome/Heliport Chart Standard Departure Chart-Instrument (AYABE, TOTTORI REVERSAL) Standard Departure Chart-Instrument (MIYAZU RNAV) Instrument Approach Chart (ILS or LOC RWY10) Instrument Approach Chart (VOR RWY10) Instrument Approach Chart (RNP RWY28(AR)) Other Chart (Visual REP) Other Chart (LDG CHART) Other Chart (MVA CHART)
--

INTENTIONALLY LEFT BLANK

RJOR / TOTTORI

AD CHART

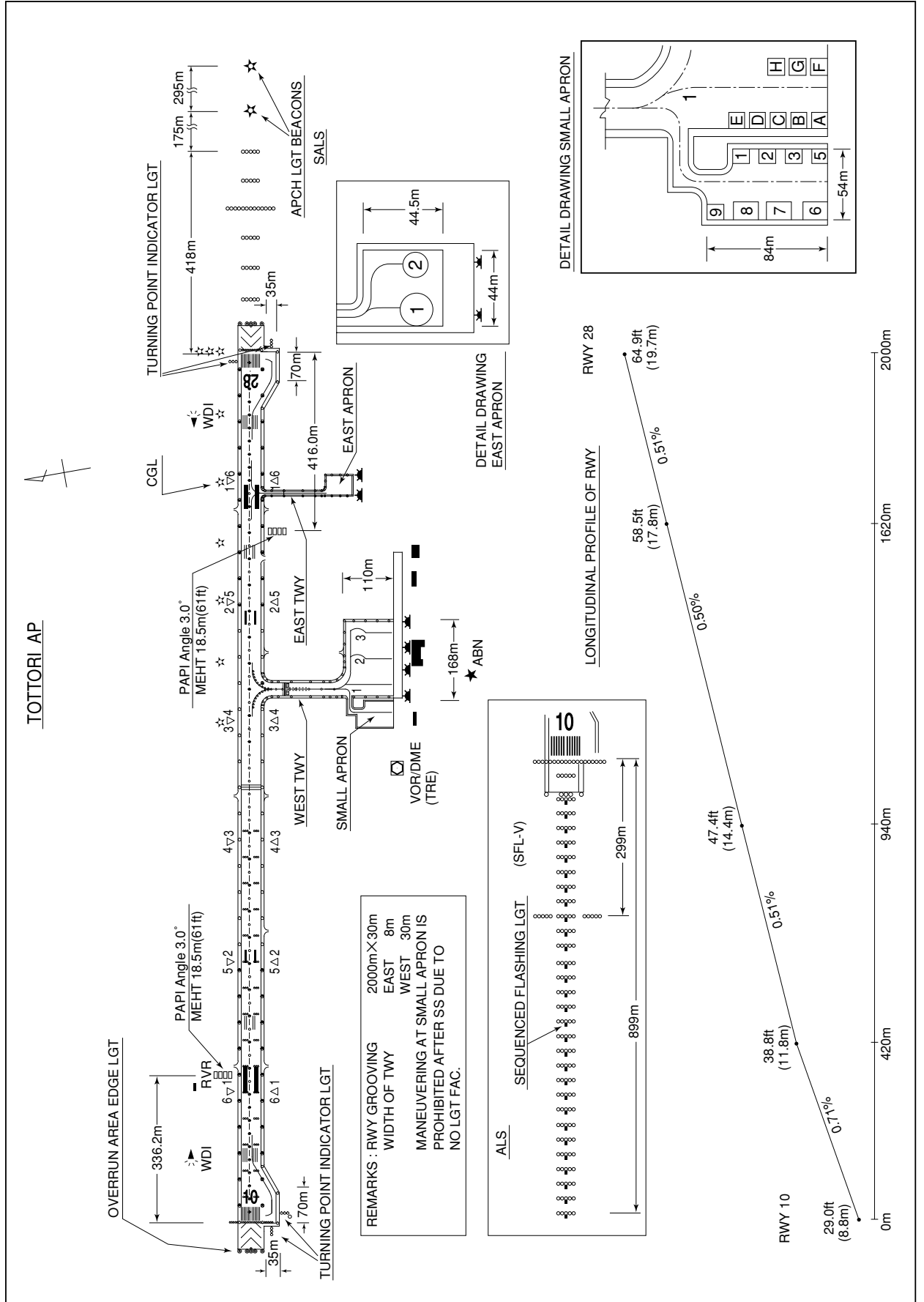

INTENTIONALLY LEFT BLANK

STANDARD DEPARTURE CHART - INSTRUMENT

RJOR / TOTTORI

SID

AYABE THREE DEPARTURE

RWY 10 : Climb RWY HDG to 500FT, turn left HDG345° ...

RWY 28 : Climb RWY HDG to 500FT, turn right HDG075° ...

...to intercept and proceed via TRE R030 to 13.0DME, turn right, via YME R300 to YME VOR/DME.

Note RWY10 : 5.5% climb gradient required up to 1300FT.

OBST ALT 1247FT located at 3.73NM 105° FM end of RWY10.

RWY28 : 4.0% climb gradient required up to 700FT.

OBST ALT 374FT located at 2.62NM 271° FM end of RWY28.

TOTTORI REVERSAL THREE DEPARTURE

RWY 10 : Climb RWY HDG to 500FT, turn left HDG345° ...

RWY 28 : Climb RWY HDG to 500FT, turn right HDG075° ...

...to intercept and proceed via TRE R030 to 13.0DME, turn left, direct to TRE VOR/DME.

Note RWY10 : 5.5% climb gradient required up to 1300FT.

OBST ALT 1247FT located at 3.73NM 105° FM end of RWY10.

RWY28 : 4.0% climb gradient required up to 700FT.

OBST ALT 374FT located at 2.62NM 271° FM end of RWY28.

TOTTORI REVERSAL THREE DEPARTURE

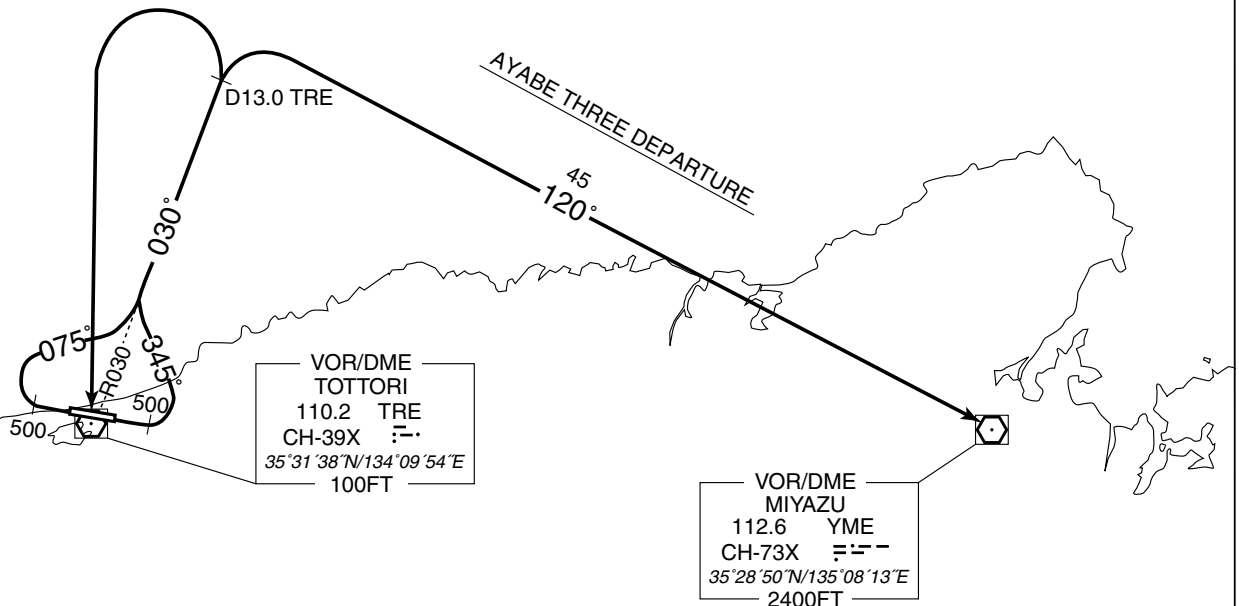

STANDARD DEPARTURE CHART -INSTRUMENT

RJOR / TOTTORI

RNAV SID

MIYAZU ONE DEPARTURE

RNP1

Note GNSS required.

VAR 8°W (2013)

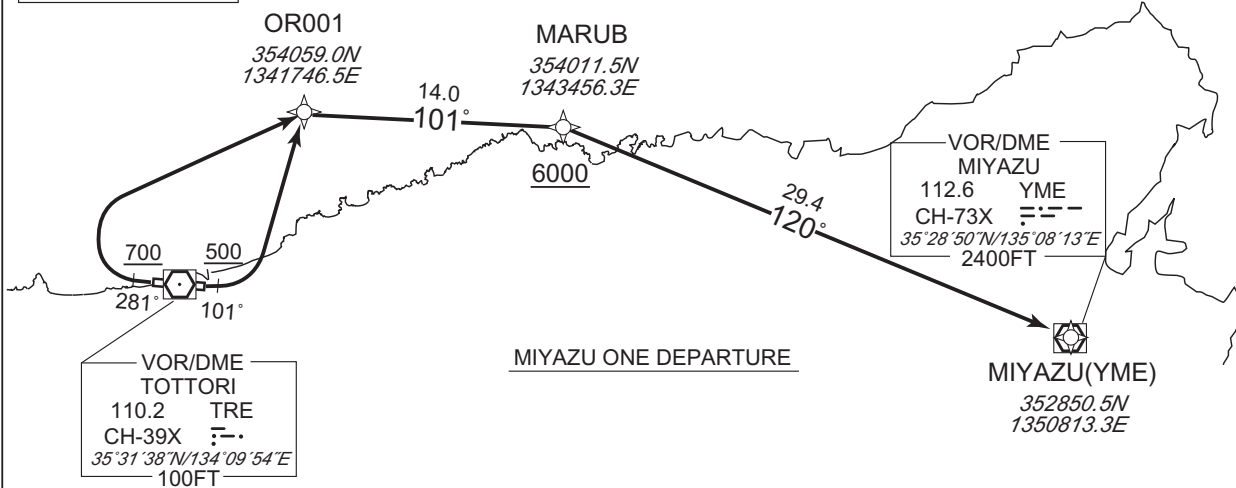

MIYAZU ONE DEPARTURE

RWY10: Climb on HDG 101° at or above 500FT, turn left direct to OR001, to MARUB at or above 6000FT, to YME.

RWY28: Climb on HDG 281° at or above 700FT, turn right direct to OR001, to MARUB at or above 6000FT, to YME.

NOTE RWY10: 5.3% climb gradient required up to 1100FT.
OBST ALT 853FT located at 3.6NM 102° FM end of RWY10.

RWY28: 3.6% climb gradient required up to 700FT.
OBST ALT 394FT located at 2.2NM 264° FM end of RWY28.

RWY10

Serial Number	Path Descriptor	Waypoint Identifier	Fly Over	Course °M(°T)	Magnetic Variation	Distance (NM)	Turn Direction	Altitude (FT)	Speed (KIAS)	Vertical Angle	Navigation Specification
001	VA	—	—	101 (093.8)	-7.6	—	—	+500	—	—	RNP1
002	DF	OR001	—	—	-7.6	—	L	—	—	—	RNP1
003	TF	MARUB	—	101 (093.2)	-7.6	14.0	—	+6000	—	—	RNP1
004	TF	YME	—	120 (112.6)	-7.6	29.4	—	—	—	—	RNP1

RWY28

Serial Number	Path Descriptor	Waypoint Identifier	Fly Over	Course °M(°T)	Magnetic Variation	Distance (NM)	Turn Direction	Altitude (FT)	Speed (KIAS)	Vertical Angle	Navigation Specification
001	VA	—	—	281 (273.8)	-7.6	—	—	+700	—	—	RNP1
002	DF	OR001	—	—	-7.6	—	R	—	—	—	RNP1
003	TF	MARUB	—	101 (093.2)	-7.6	14.0	—	+6000	—	—	RNP1
004	TF	YME	—	120 (112.6)	-7.6	29.4	—	—	—	—	RNP1

CHANGE : Navigation Specification(Basic RNP1 → RNP1).

INSTRUMENT APPROACH CHART

RJOR / TOTTORI ILS or LOC RWY10

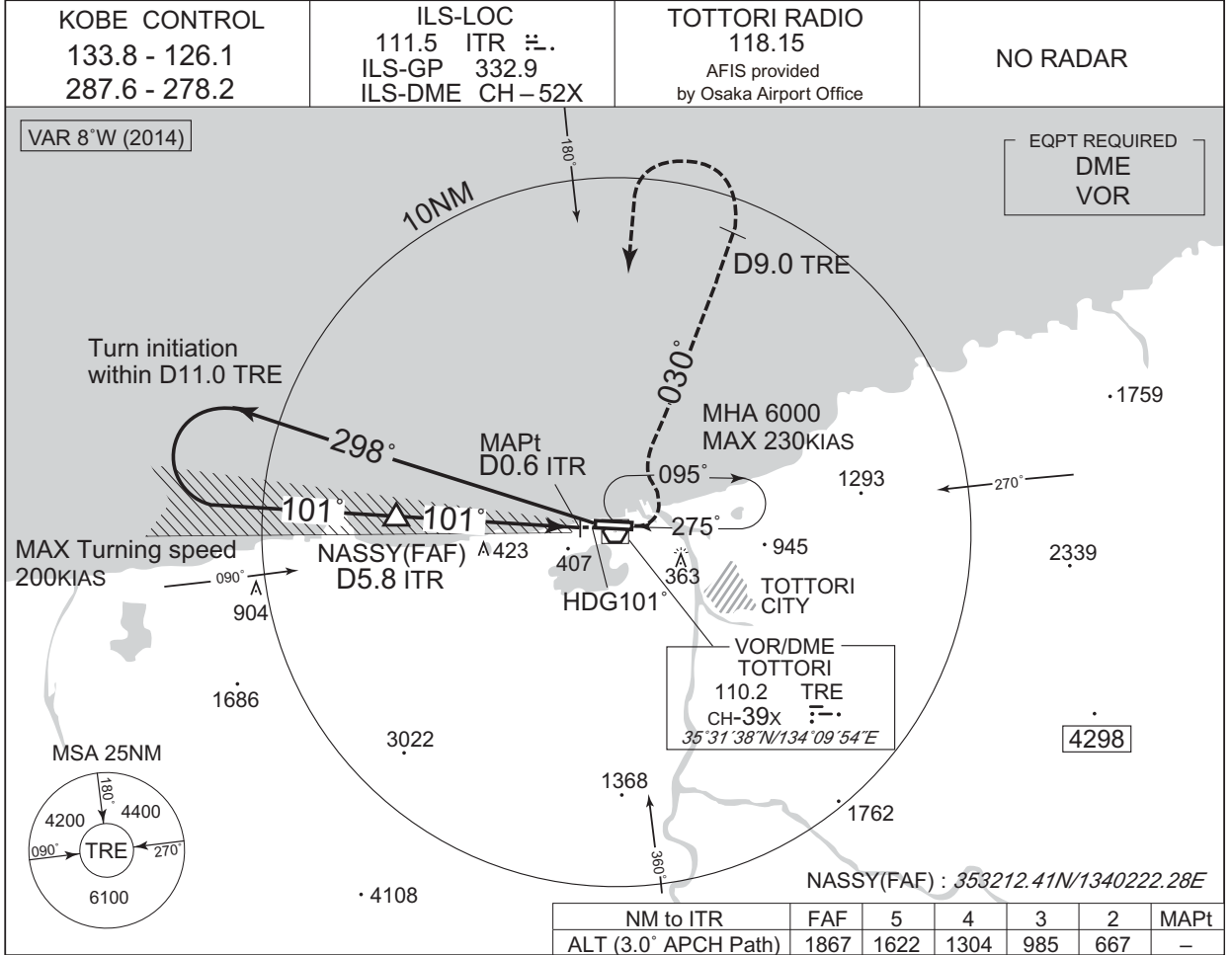

CHANGE : FREQ for KOBE CONTROL.

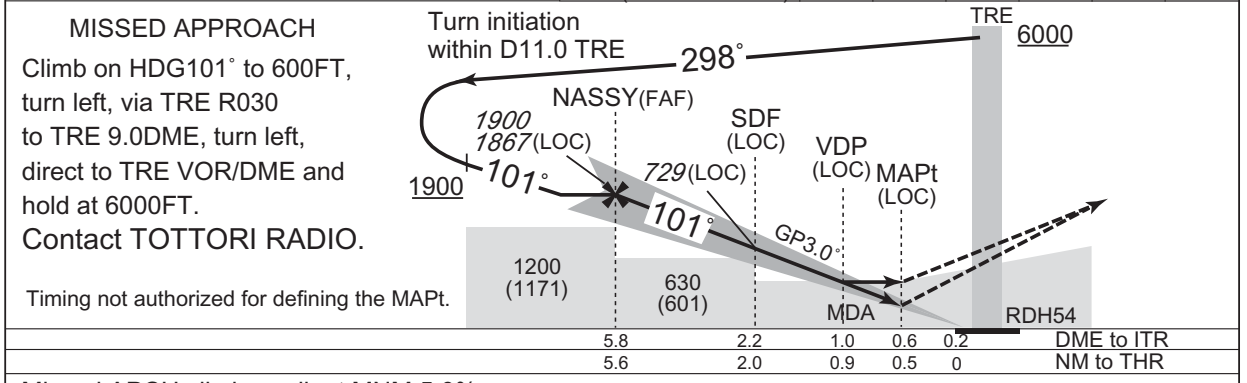

Missed APCH climb gradient MNM 5.0%

MINIMA		THR elev. 29		AD elev. 48			
CAT	CAT I		LOC		CIRCLING		
	DA(H)	RVR/CMV	MDA(H)	RVR/CMV	MDA(H)	VIS	
A	229 (200)	550	350 (321)	900	790 (742)	590 (542)	1600
B				1000			
C				1400	840 (792)	760 (712)	3200
D							

MINIMA with Missed APCH climb gradient of 2.5% are not established.

INSTRUMENT APPROACH CHART

RJOR / TOTTORI

VOR RWY10

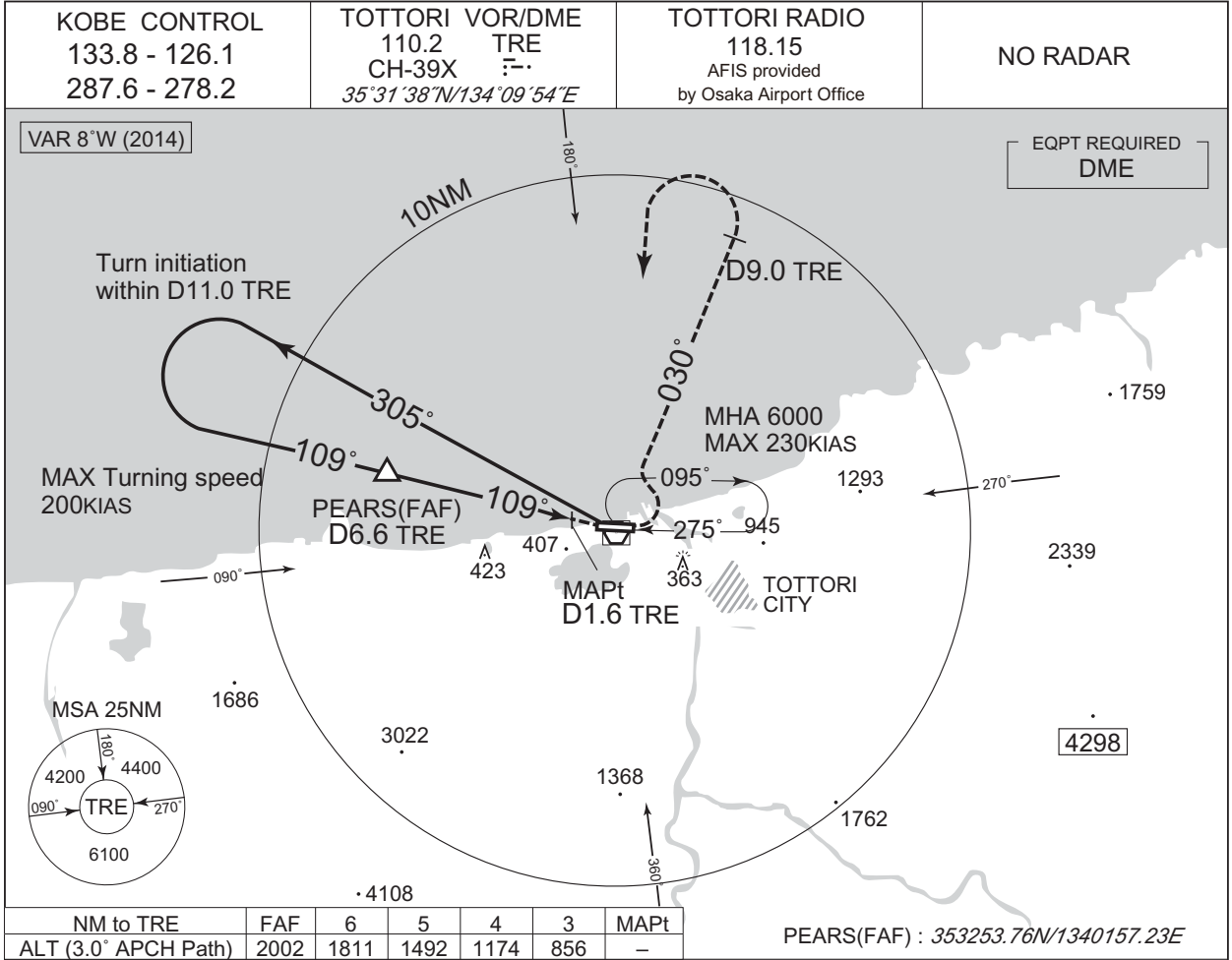

CHANGE : FREQ for KOBE CONTROL.

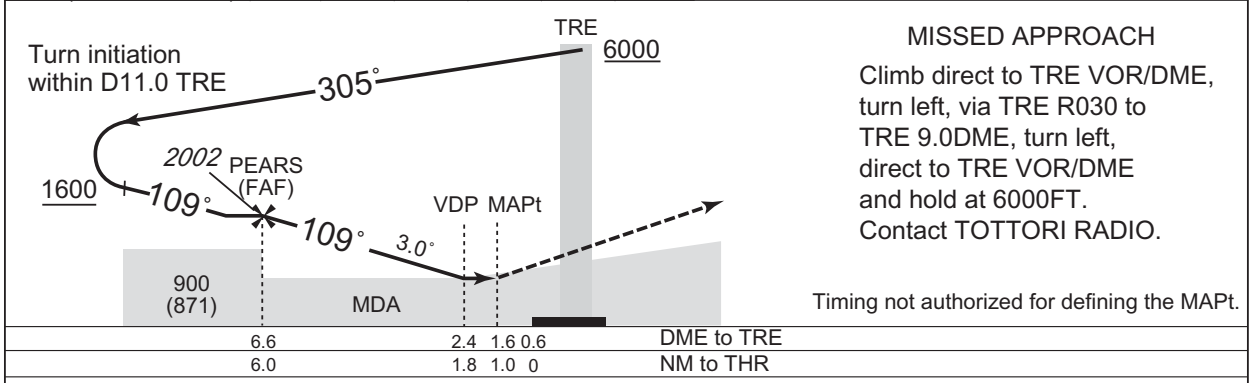

MINIMA		THR elev. 29	AD elev. 48	
CAT	MDA(H)	RVR/ CMV	CIRCLING	
			TOTAL AREA	NORTH of RWY
A	630 (601)	1000	790 (742)	630 (582)
B	640 (611)	1200		640 (592)
C	640 (611)	1600	840 (792)	760 (712)
D	650 (621)			3200

INSTRUMENT APPROACH CHART

RJOR / TOTTORI

RNP RWY28(AR)

KOBE CONTROL 133.8 - 126.1 287.6 - 278.2	RNP AR RF required.	TOTTORI RADIO 118.15 AFIS provided by Osaka Airport Office	NO RADAR
--	------------------------	---	----------

For uncompensated Baro-VNAV systems, procedure not authorized below -5°C / above 45°C

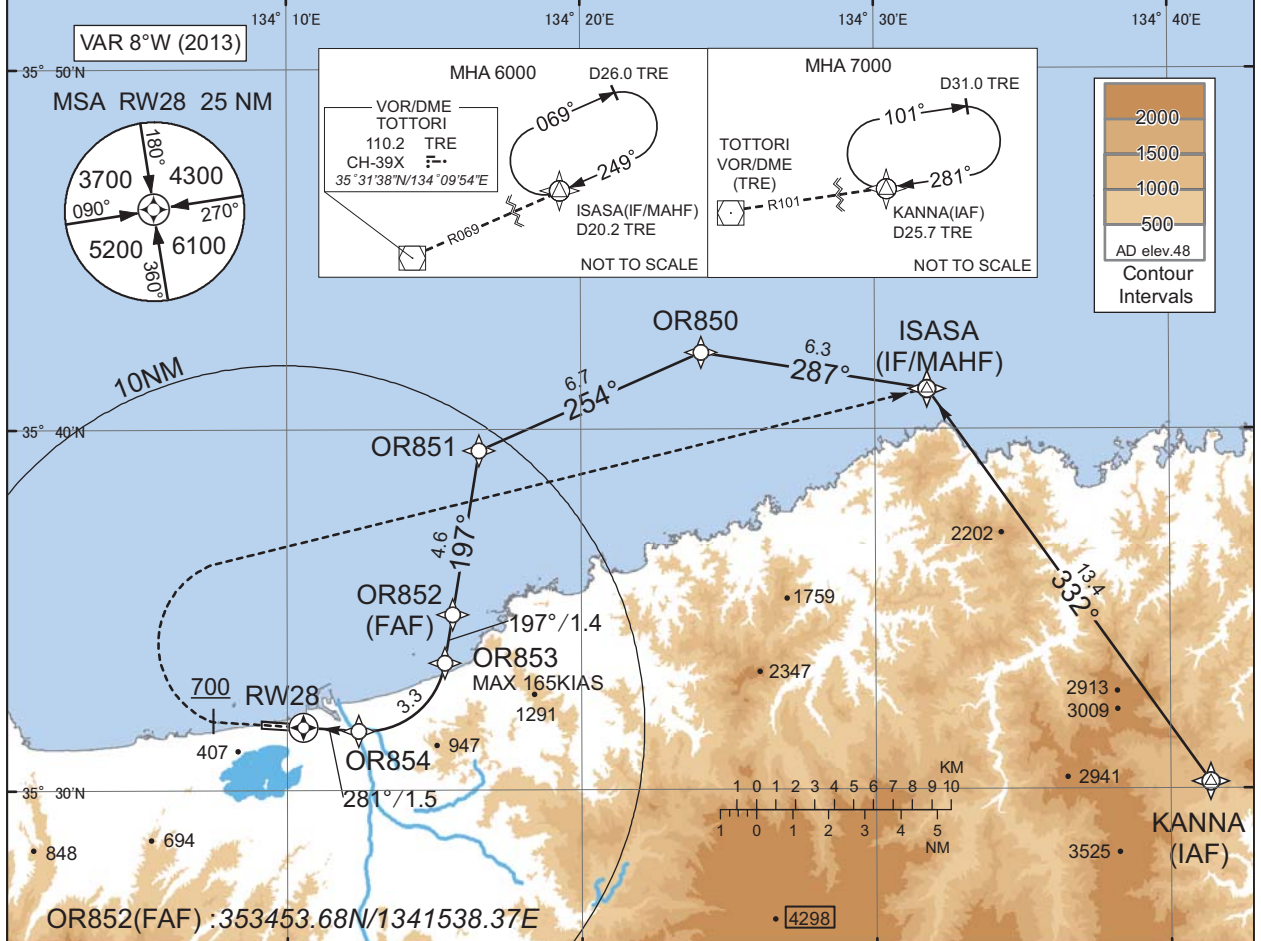

MISSED APPROACH

From RW28 on track 281°, at or above 700FT turn right, direct to ISASA and hold at 6000FT. Contact TOTTORI RADIO.

CHANGE : FREQ for KOBE CONTROL.

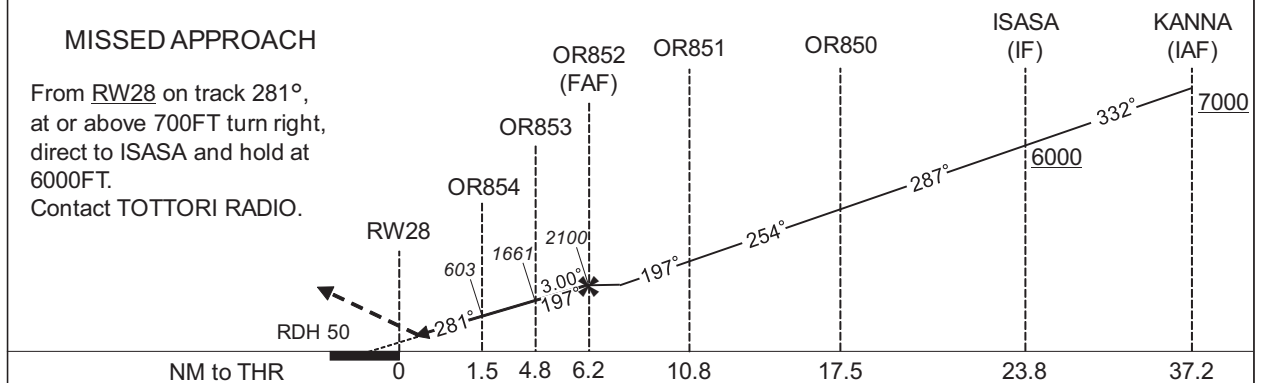

MINIMA	THR elev. 65	AD elev. 48
CAT	RNP 0.30	
	DA(H)	CMV
A	-	-
B	-	-
C	365(300)	1600
D	-	1800

Authorization Required

Missed APCH climb gradient MNM 3.4%

INSTRUMENT APPROACH CHART

RJOR / TOTTORI

RNP RWY28(AR)

Coding Table

Serial Number	Path Descriptor	Waypoint Identifier	Fly Over	Course °M(°T)	Magnetic Variation	Distance (NM)	Turn Direction	Altitude (FT)	Speed (KIAS)	VPA/RDH (°/FT)	RNP Value
001	IF	KANNA	-	-	-7.6	-	-	+7000	-	-	-
002	TF	ISASA	-	332 (324.6)	-7.6	13.4	-	+6000	-	-	1.0
003	TF	OR850	-	287 (279.4)	-7.6	6.3	-	-	-	-	1.0
004	TF	OR851	-	254 (246.2)	-7.6	6.7	-	-	-	-	1.0
005	TF	OR852	-	197 (189.2)	-7.6	4.6	-	2100	-	-	1.0
006	TF	OR853	-	197 (189.2)	-7.6	1.4	-	1661	-165	-3.00	0.3
007	RF Center: ORRF1 r=2.25NM	OR854	-	-	-7.6	3.3	R	603	-	-3.00	0.3
008	TF	RW28	Y	281 (273.8)	-7.6	1.5	-	115	-	-3.00/50	0.3
009	FA	-	-	281 (273.8)	-7.6	-	-	+700	-	-	1.0
010	DF	ISASA	-	-	-7.6	-	R	6000	-	-	1.0

Waypoint Coordinates

Waypoint Identifier	Coordinates	RF Arc Center Identifier	Coordinates
KANNA	353011.27N / 1344121.95E	ORRF1	353354.77N / 1341238.96E
ISASA	354107.52N / 1343147.31E		
OR850	354209.38N / 1342406.43E		
OR851	353926.62N / 1341632.67E		
OR852	353453.68N / 1341538.37E		
OR853	353333.13N / 1341522.36E		
OR854	353139.90N / 1341226.53E		
RW28	353146.03N / 1341033.79E		

CHANGE : PROC renamed.

RJOR / TOTTORI

Visual REP

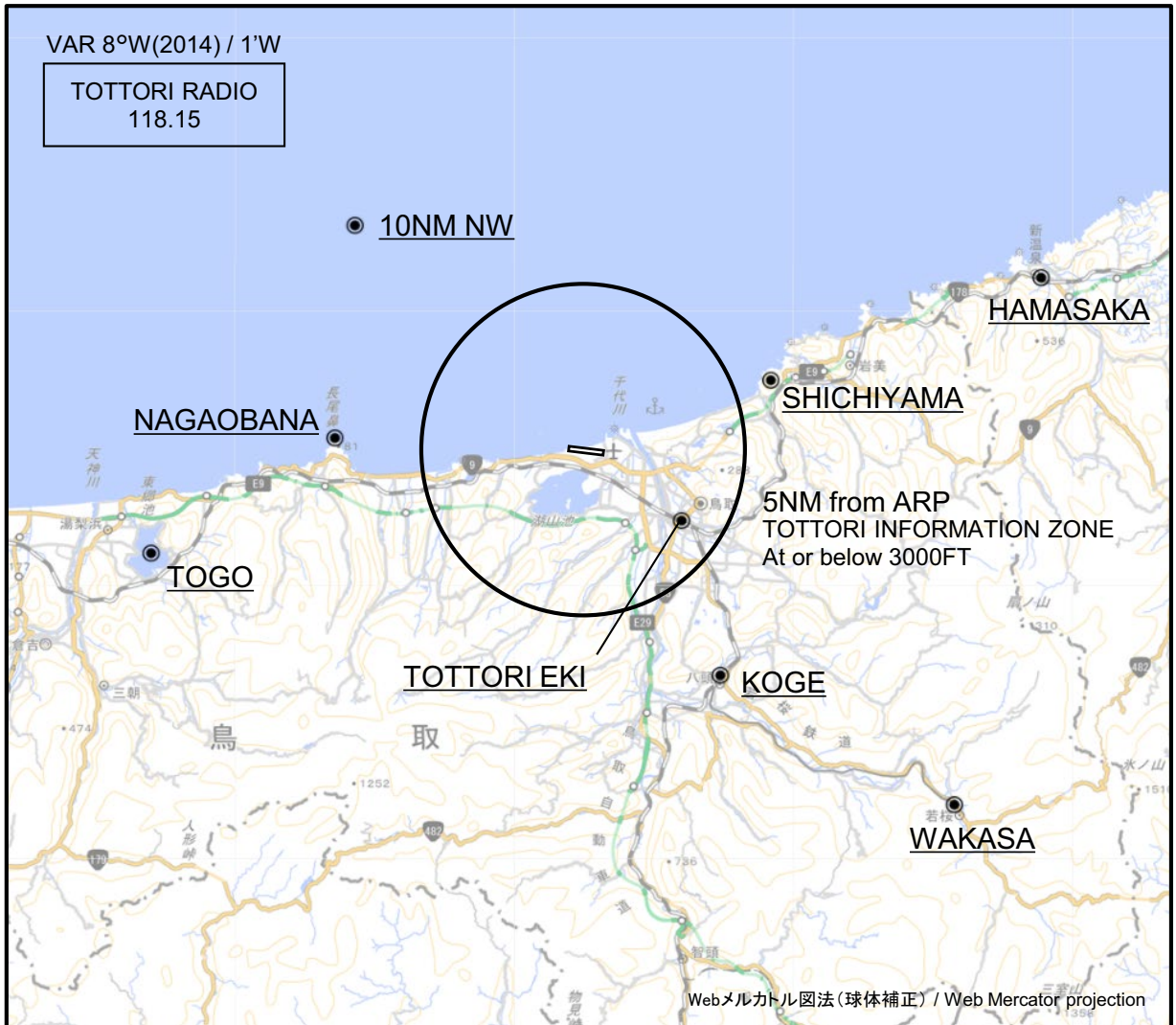

※図中に標高を示す数字がある場合、単位はメートル(m)である。The unit of measurement used to express elevation is meter(m).

CHANGE : Secondary FREQ abolished.

Call sign	BRG / DIST from ARP	Remarks
10NM NW	315°T / 10.0NM	海上 Over the sea
浜坂 Hamasaka	069°T / 15.1NM	駅 Station
駟馳山 Shichiyama	069°T / 6.2NM	山 Mountain
長尾鼻 Nagaobana	273°T / 7.7NM	岬 Cape
鳥取駅 Tottori eki	126°T / 3.7NM	駅 Station
東郷 Togo	257°T / 13.7NM	池 Pond
郡家 Koge	149°T / 8.2NM	駅 Station
若桜 Wakasa	134°T / 15.9NM	駅 Station

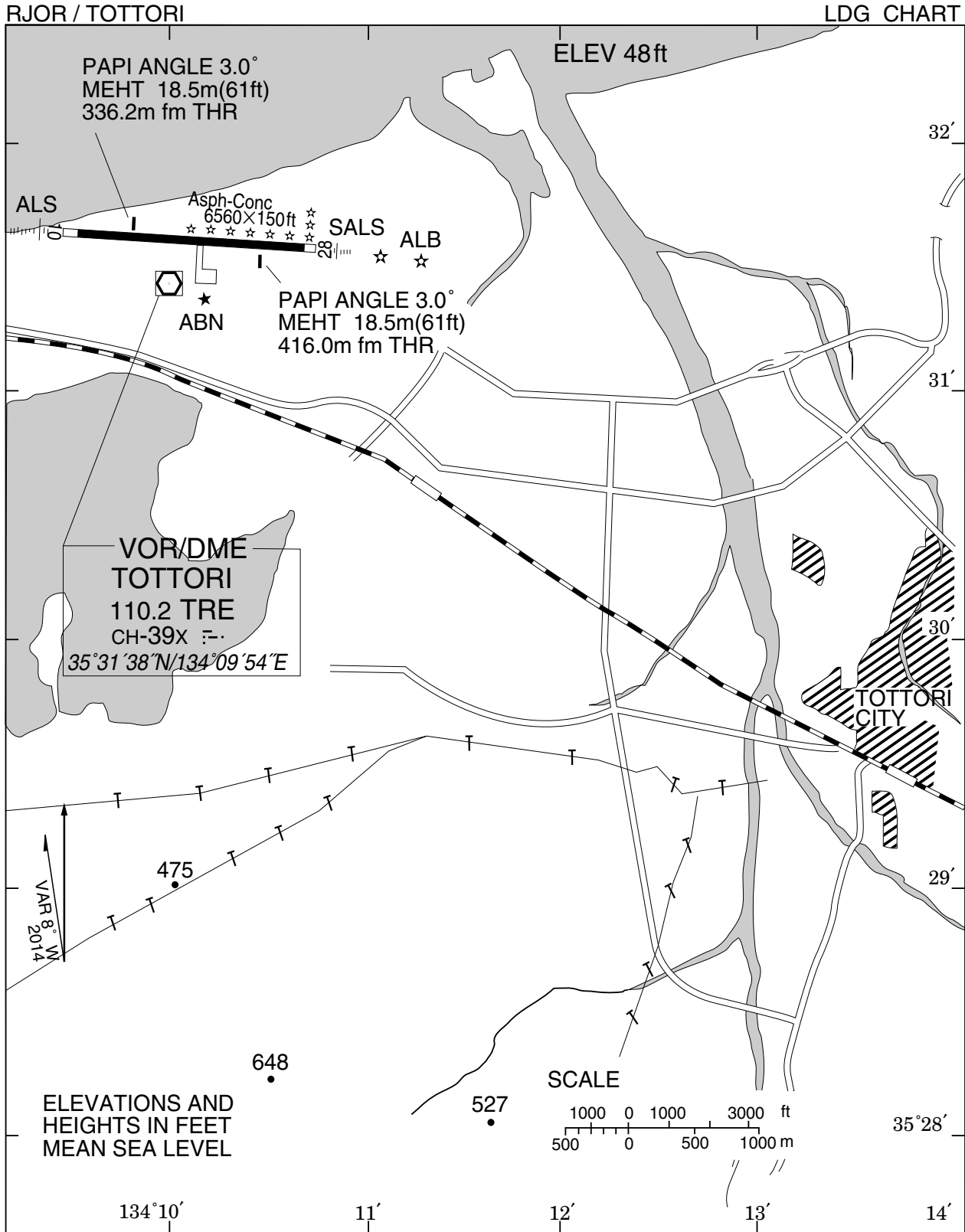

RJOR / TOTTORI

Minimum Vectoring Altitude CHART

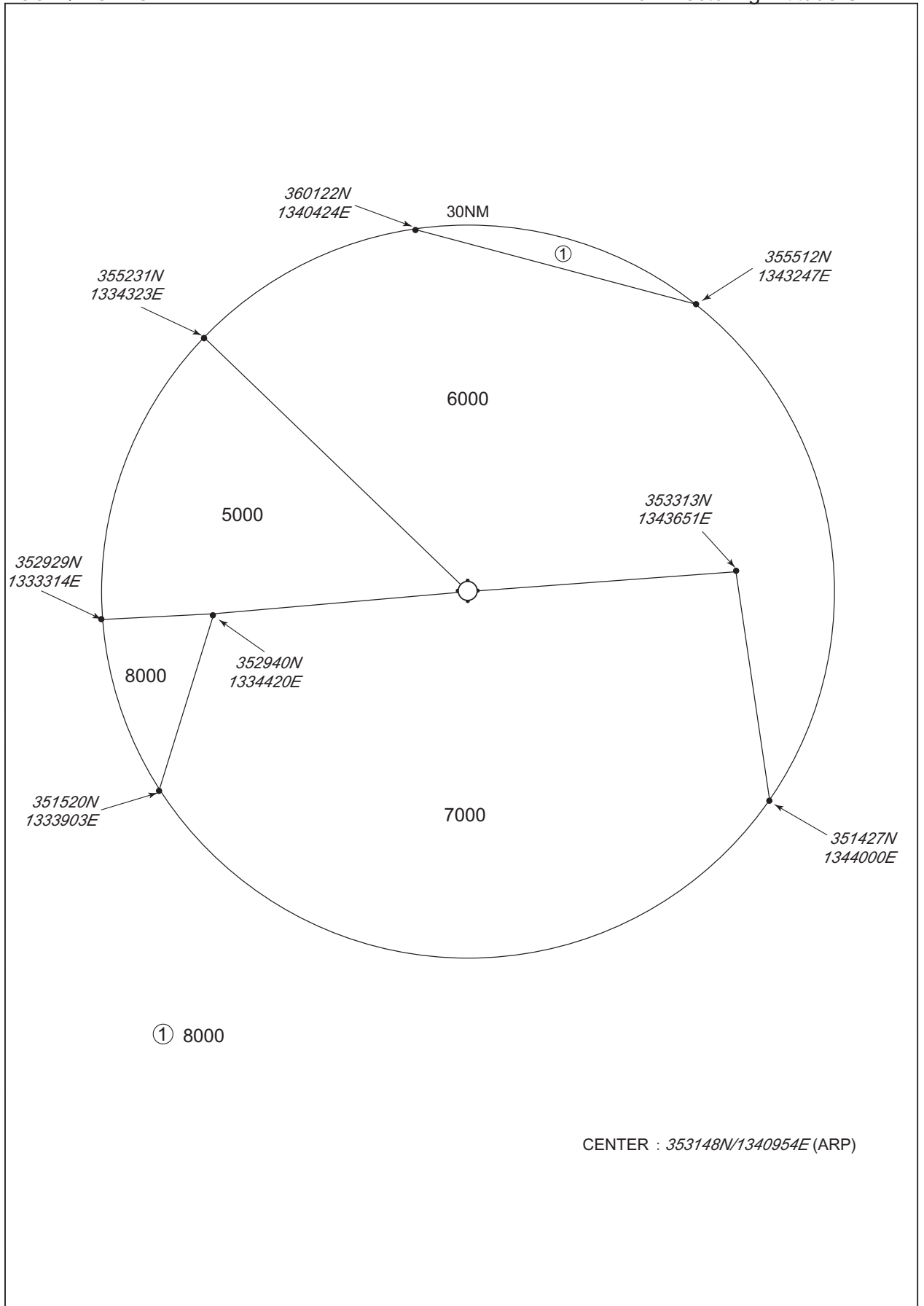

INTENTIONALLY LEFT BLANK