

AD 2 AERODROMES

RJSA AD 2.1 AERODROME LOCATION INDICATOR AND NAME

RJSA -AOMORI

RJSA AD 2.2 AERODROME GEOGRAPHICAL AND ADMINISTRATIVE DATA

1	ARP coordinates and site at AD	404400N/1404119E 052° / 1.5km from RWY 06 THR
2	Direction and distance from (city)	11.2Km(6NM) SSW from Aomori Railway station
3	Elevation/ Reference temperature	650ft / 26°C (2000-2005)
4	Geoid undulation at AD ELEV PSN	Nil
5	MAG VAR/ Annual change	9° W(2005) / -
6	AD Administration, address, telephone, telefax, telex, AFS, e-mail and/or Web-site addresses	Aomori Airport Administration Office 1-5, Kotani, Ootani, Aomori City, Aomori, 030-0155, Japan Tel: 017-739-2121, Fax: 017-739-2780 E-mail: airport@pref.aomori.lg.jp
7	Types of traffic permitted(IFR/VFR)	IFR/VFR
8	Remarks	Aomori Airport Branch (Civil Aviation Bureau) 1-303, Kotani, Ootani, Aomori-City, Aomori, 030-0155, Japan Tel: 017-739-2240, Fax: 017-739-2273

RJSA AD 2.3 OPERATIONAL HOURS

1	AD Administration	2230-1300
2	Customs and immigration	INTL SKED FLT hours only
3	Health and sanitation	INTL SKED FLT hours only
4	AIS Briefing Office	Nil
5	ATS Reporting Office(ARO)	Nil
6	MET Briefing Office	H24 (TOKYO)
7	ATS	2230-1300
8	Fuelling	Airline : 2200-1230 (Tel: 017-739-6280) General Aviation: 2300-SS and On request(Tel : 017-739-3741)
9	Handling	Nil
10	Security	2230-1300
11	De-icing	Nil
12	Remarks	Nil

RJSA AD 2.4 HANDLING SERVICES AND FACILITIES

1	Cargo-handling facilities	Nil
2	Fuel/ oil types	Airline : JET A1 General Aviation : JET A1, AVGAS 100/ Aviation oil
3	Fuelling facilities/ capacity	Airline : Fuel truck refueling/ JET A1 200kl x 2tank The prior permission of Oil company is required for refueling. (Except schedule Flight) General Aviation : Fuel truck refueling / JET A1 28kl, AVGAS 5.6kl
4	De-icing facilities	Nil
5	Hangar space for visiting aircraft	Nil
6	Repair facilities for visiting aircraft	Nil
7	Remarks	Nil

RJSA AD 2.5 PASSENGER FACILITIES

1	Hotels	Hotels in Aomori city
2	Restaurants	At Airport
3	Transportation	Buses and Taxi
4	Medical facilities	First aid treatment, Hospital in Aomori city 10km
5	Bank and Post Office	Bank and Post Office in Aomori city
6	Tourist Office	Tourist Office in Aomori city
7	Remarks	Nil

RJSA AD 2.6 RESCUE AND FIRE FIGHTING SERVICES

1	AD category for fire fighting	CAT 9
2	Rescue equipment	Chemical fire fighting truck x 3 Emergency medical equipment conveyance truck
3	Capability for removal of disabled aircraft	Nil
4	Remarks	Nil

RJSA AD 2.7 SEASONAL AVAILABILITY-CLEARING

1	Types of clearing equipment	<p>Snow remove equipments:</p> <p>Snow sweeper × 4</p> <p>Snow plow × 10</p> <p>Rotary plow × 4</p> <p>Anti-freezing sprayer × 3</p> <p>Continuous friction measuring equipment × 2</p> <p>Dump trucks, dozers, supervisory vehicles, etc.</p>
2	Clearance priorities	RWY06/24, all TWY, and Apron
3	Remarks	Snow removal will be commenced, if the RWY are covered with a depth of 3cm snow or more.

RJSA AD 2.8 APRONS, TAXIWAYS AND CHECK LOCATIONS DATA

1	Apron surface and strength	<p>Spot NR 1 - 6</p> <p>Surface : cement-concrete, Strength: PCN 62/R/B/X/T</p> <p>N-Apron</p> <p>Spot NR N1 - N2</p> <p>Surface : asphalt-concrete, Strength: AUW 11.0t</p> <p>Spot NR N3 - N11</p> <p>Surface : asphalt-concrete, Strength: AUW 5.7t</p>
2	Taxiway width, surface and strength	<p>TWY T0 - T5, P1 - P4</p> <p>Width : 30m, Surface: asphalt-concrete, Strength: PCN 86/F/C/X/T</p> <p>TWY N</p> <p>Width : 10.5m, Surface: asphalt-concrete, Strength: AUW 11.0t</p>
3	ACL and elevation	Not available
4	VOR checkpoints	Not available
5	INS checkpoints	<p>Spot Nr</p> <p>1 404413.68N1404118.37E</p> <p>2 404414.96N1404120.20E</p> <p>3 404416.50N1404122.54E</p> <p>4 404417.75N1404124.77E</p> <p>5 404419.15N1404126.98E</p> <p>6 404420.45N1404128.90E</p>
6	Remarks	Nil

RJSA AD 2.9 SURFACE MOVEMENT GUIDANCE AND CONTROL SYSTEM AND MARKINGS

1	Use of aircraft stand ID signs, TWY guide lines and Visual docking/ parking guidance system of aircraft stands	Nil
2	RWY and TWY markings and LGT	<p>RWY : RWY06/24 (Marking) : RWY designation, RWY CL, RWY THR, Aiming point, TDZ, RWY side stripe (LGT) : RCLL, REDL, RTHL, RENL, RTZL(RWY 24), WBAR(RWY 24), RWY DIST markar LGT</p> <p>TWY: TWY T0 THRU T5 (Marking) : TWY CL, TWY side stripe, RWY HLDG PSN (LGT) : TWY edge LGT, TWY CL LGT, RWY guard LGT, Taxiing guidance sign</p> <p>TWY: TWY P1 THRU P4 (Marking) : TWY CL, TWY side stripe (LGT) : TWY edge LGT, TWY CL LGT, Taxiing guidance sign</p> <p>TWY: TWY N (Marking) : TWY CL, TWY side stripe (LGT) : TWY edge LGT</p>
3	Stop bars	<p>Stop bar lights: TWY T0 THRU T5 Stop bar lights operations are as follows;</p> <ol style="list-style-type: none"> 1) Stop bar lights installed at each taxi-holding position with RWY06/24 2) Stop bar lights will be operated when the visibility or the lowest RVR of RWY06/24 is at or less than 600m 3) Stop bar lights on TWY T0 and T5 are controlled individually by ATC 4) Stop bar lights on TWY T1 through T4 are not controlled individually by ATC 5) During the period stop bar lights are operated, TWY T1 through T4 are not available for the departing aircraft
4	Remarks	<p>(Marking) : Overrun area, ACFT PRKG PSN, Apron TWY CL (LGT) : Apron flood LGT</p>

RJSA AD 2.10 AERODROME OBSTACLES

In Area2 See Obstacle data

Other obstacles

OBST ID/ designation	Obstacle type	Coordinates	Elevation	Markings/LGT	Remarks
RJSA1	MT	404256.9N/1403948.5E	730ft	- / LIM	Under approach SFC
RJSA2	BLDG	404440.2N/1404219.8E	678ft	- / LIM	Under approach SFC
RJSA3	Snow fence	404433.5N/1404224.7E	677ft	- / LIM	Under approach SFC
RJSA4	Snow fence	404432.3N/1404227.0E	679ft	- / LIM	Under approach SFC
RJSA5	Hill	404326.4N/1404039.7E	691ft	- / LIM	Under transitional SFC
RJSA6	Hill	404356.8N/1404130.7E	692ft	- / LIM	Under transitional SFC
RJSA7	MT	404239.0N/1404001.1E	795ft	- / LIM	Under horizontal SFC
RJSA8	Tower	404435.7N/1404132.2E	717ft	- / LIM	Under horizontal SFC

In Area3 To be developed

RJSA AD 2.11 METEOROLOGICAL INFORMATION PROVIDED

1	Associated MET Office	TOKYO
2	Hours of service MET Office outside hours	H24 (TOKYO)
3	Office responsible for TAF preparation Periods of validity	TOKYO 30 Hours
4	Trend forecast Interval of issuance	Nil.
5	Briefing/ consultation provided	Briefing is available upon inquiry at TOKYO
6	Flight documentation Language(s) used	C En
7	Charts and other information available for briefing or consultation	S ₆ , U ₈₅ , U ₇ , U ₅ , U ₃ , U ₂₅ , U ₂ /T _r , P _s , P ₅ , P ₃ , P ₂₅ , P _{SWE} , P _{SWF} , P _{SWG} , P _{SWI} , P _{SWM} , P _{SW} , (domestic), E, C, W _E , W _F , W _G , W _I , W, N
8	Supplementary equipment available for providing information	Nil
9	ATS units provided with information	TWR
10	Additional information(limitation of service, etc.)	Nil

RJSA AD 2.12 RUNWAY PHYSICAL CHARACTERISTICS

Designations RWY NR	TRUE BRG	Dimensions of RWY(M)	Strength(PCN) and surface of RWY	THR coordinates THR geoid undulation	THR elevation and highest elevation of TDZ of precision APP RWY
1	2	3	4	5	6
06	051.91°	3000 x 60	PCN 86/F/C/X/T Asphalt Concrete	404329.77N 1404028.61E 122.6ft	THR ELEV : 647ft
24	231.91°	3000 x 60	PCN 86/F/C/X/T Asphalt Concrete	404429.79N 1404209.27E 122.6ft	THR ELEV : 664ft TDZ ELEV : 661ft

Slope of RWY	Strip dimensions(M)	RESA (Overrun) Dimensions(M)	Remarks
7	10	11	14
See below figure	3120x 300 3120x 300	40 x 300 190 x (MNM:160 MAX:300)* *For detail, ask airport administrator	RWY grooving : 3000m x 60m

The diagram shows the elevation profile of the runways. RWY 06 starts at 647ft at 0m. It has a 0.5% slope to 653ft at 380m, then a 0.1% slope to 650ft at 1520m. RWY 24 starts at 653ft at 500m and has a 0.3% slope to 664ft at 3000m.

RJSA AD 2.13 DECLARED DISTANCES

RWY Designator	TORA (m)	TODA (m)	ASDA (m)	LDA (m)	Remarks
1	2	3	4	5	6
06	3000	3000	3000	3000	Nil
24	3000	3000	3000	3000	Nil

RJSA AD 2.14 APPROACH AND RUNWAY LIGHTING

RWY Designator	APCH LGT type LEN INTST	RTHL Color WBAR	PAPI (VASIS) Angle DIST FM THR MEHT	RTZL LEN	RCLL LEN Spacing Color INTST	REDL LEN Spacing Color INTST	RENL Color WBAR	STWL LEN Color
1	2	3	4	5	6	7	8	9
06	SALS 420m LIH	Green -	PAPI 3.0°/Left 423m 74ft	-	3000m 15m Coded color (White/Red) LIH	3000m 60m Coded color (White/Yellow) LIH	Red	Nil (*1)
24	PALS (CATIII) 900m LIH	Green Green	PAPI 3.0°/Left 440m 66ft	900m	3000m 15m Coded color (White/Red) LIH	3000m 60m Coded color (White/Yellow) LIH	Red	Nil (*1)
Remarks								
10								
Overrun area edge LGT(LEN : 60m, color : Red) (*1) CGL for RWY 06								

RJSA AD 2.15 OTHER LIGHTING, SECONDARY POWER SUPPLY

1	ABN/IBN location, characteristics and hours of operation	ABN : 404420N/1404111E, White/Green EV4.3sec, HO
2	LDI location and LGT Anemometer location and LGT	LDI : Nil Anemometer : RWY06 : 377m from RWY06 THR, LGTD RWY24 : 306m from RWY24 THR, LGTD
3	TWY edge and center line lighting	TWY edge and center line lights installed, see AD2.9
4	Secondary power supply/ switch-over time	Within 1sec : PALS, SALS, REDL, RTHL, WBAR, RENL, RCLL, RTZL, Overrun area edge LGT, Stop bar LGT, RWY guard LGT and TWY CL LGT at TWY T0, T5, P1-P4 Within 15sec : Other lights
5	Remarks	WDI LGT

RJSA AD 2.16 HELICOPTER LANDING AREA

To Be Developed

RJSA AD 2.17 ATS AIRSPACE

Designation and lateral limits		Vertical limits (ft)	Airspace classification	ATS unit call sign Language	Remarks
1		2	3	4	6
AOMORI CTR	Area within a radius of 5NM of Aomori ARP(4044N/14041E)	----- 4000	D	Aomori TWR En	
Shirakami ACA	See RJSK attached chart		E	Shirakami APP En	

RJSA AD 2.18 ATS COMMUNICATION FACILITIES

Service designation	Call sign	Frequency	Hours of operation	Remarks
1	2	3	4	5
APP	Shirakami Approach	119.25MHz 315.3MHz 120.65MHz 243.0MHz(E)	2200-1300	
TWR	Aomori Tower	118.3MHz(1) 126.2MHz 243.0MHz(E)	2230-1300	(1)Primary

RJSA AD 2.19 RADIO NAVIGATION AND LANDING AIDS

Type of aid (VOR declination)	ID	Frequency	Hours of operation	Position of transmitting antenna coordinates	Elevation of DME transmitting antenna	Remarks
1	2	3	4	5	6	7
VOR (9°W/2022)	MRE	114.1MHz	H24	404419.65N 1404219.20E		VOR unusable: 120°-150° beyond 15nm BLW 8000ft. 150°-160° beyond 15nm BLW 7000ft. 160°-190° beyond 25nm BLW 7000ft. 190°-200° beyond 25nm BLW 6000ft.
DME	MRE	1175MHz (CH-88X)	H24	404420.20N 1404217.77E	756ft	DME unusable: 100°-110° beyond 35nm BLW 8000ft. 110°-120° beyond 30nm BLW 8000ft. 120°-130° beyond 15nm BLW 8000ft. 130°-150° beyond 20nm BLW 8000ft. 150°-190° beyond 20nm BLW 7000ft. 190°-200° beyond 20nm BLW 6000ft. 200°-220° beyond 35nm BLW 6000ft.
ILS-LOC 24	IMR	111.9MHz	2230-1300	404325.19N 1404020.96E		LOC : 230m(755ft) away FM RWY 06 THR, BRG(MAG) 240.93°
ILS-GP 24	-	331.1MHz	2230-1300	404419.64N 1404201.60E		GP : 334m(1096ft) inside FM RWY24 THR, 135m(443ft) S of RCL. HGT of ILS REF datum 16.5m(54ft). GP angle 3.0°
ILS-DME 24	IMR	1017MHz (CH-56X)	2230-1300	404419.38N 1404201.87E	672ft	DME : 334m(1096ft) inside FM RWY 24 THR, 145m(476ft) S of RCL
IM 24	-	75MHz	2230-1300	404435.33N 1404218.46E		IM : 276m(0.15nm) away FM RWY 24 THR
MSAS		1575.42MHz	H24			Transmitting antennas are satellite based.

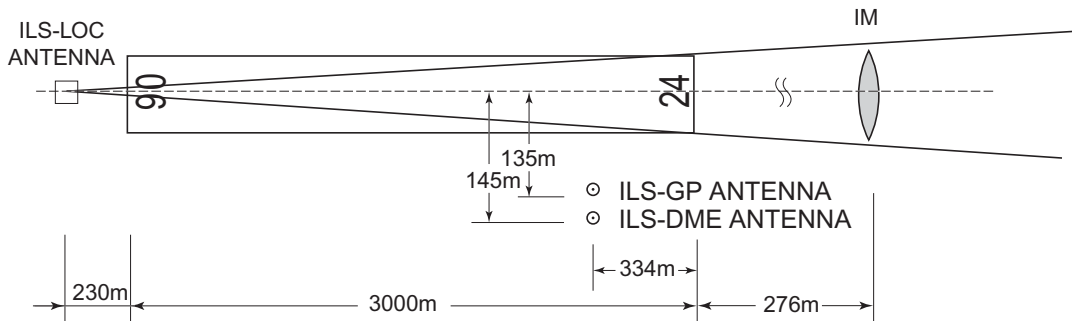

REMARKS : 1.LOC Beam BRG(MAG) 240.93°
 2.HGT of ILS REF datum 54ft
 3.GP Angle 3.0°
 4.ELEV of ILS-DME 204.6m(672ft)

RJSA AD 2.20 LOCAL TRAFFIC REGULATIONS

1. Airport regulations

定期便または緊急事態以外の航空機の取扱い 青森空港の使用について、航空機の運航者はあらかじめ空港管理事務所の許可を得ること。	Aircraft operations other than scheduled flights or in an emergency On use of AOMORI airport, aircraft operator is required to obtain the permission of the airport authority.
---	--

2. Taxiing to and from stands

Nil

3. Parking area for small aircraft(General aviation)

Nil

4. Parking area for helicopters

Nil

5. Apron - taxiing during winter conditions

Nil

6. Taxiing - limitations

Wing tip clearance at the TWY intersection (REF AD1.1.6.8)

Wing tip clearance at the TWY intersection between the aircraft holding at the stop marking on the TWY and the other aircraft taxiing behind it are as follows.

(1)When A306 holding at the stop marking on TWY T2, T3 or T4

Wing Span (WS) of aircraft taxiing on TWY P1-P4	WS ≤ 22.2m	22.2m < WS ≤ 39.2m	WS > 39.2m
Wing tip clearance	*A	*B	*E

(2)When A306 holding at the stop marking on TWY T1

Wing Span (WS) of aircraft taxiing on TWY T0-P1	WS ≤ 5.4m	5.4m < WS ≤ 14.4m	WS > 14.4m
Wing tip clearance	*A	*C	*D

Legend:

*A : wing tip clearance ≥ 15m

*B : 6.5m ≤ wing tip clearance < 15m

*C : 10.5m ≤ wing tip clearance < 15m

*D : wing tip clearance < 10.5m

*E : wing tip clearance < 6.5m

7. School and training flights - technical test flights - use of runways

Nil

8. Helicopter traffic - limitation

Nil

9. Removal of disabled aircraft from runways

Nil

RJSA AD 2.21 NOISE ABATEMENT PROCEDURES

Nil

RJSA AD 2.22 FLIGHT PROCEDURES

1.TAKE OFF MINIMA

	RWY	ACFT CAT	REDL & RCLL		REDL or RCLL or RCL Marking		NIL (DAYTIME ONLY)	
			RVR	VIS	RVR	VIS	RVR	VIS
Multi-Engine ACFT with TKOF ALTN AP FILED	06 24	A,B,C	400m *200m **150m	400m *200m	400m *250m	400m *250m	-	500m
		D	400m *250m **200m	400m *250m	400m *300m	400m *300m	-	500m
OTHER	06 24	A,B,C,D	AVBL LDG MINIMA					

*APPLICABLE WHEN LVP/LVPD IN FORCE.

**APPLICABLE WHEN LVP/LVPD IN FORCE and MULTIPLE RVRs AVAILABLE.

2. Lost communication procedures for arrival aircraft under radar navigational guidance

If radio communications with Shirakami Approach are lost for 1 minute, squawk Mode A/3 Code 7600 and;

(I) 1. Contact Aomori Tower.

2. If unable, proceed in accordance with visual flight rules.

3. If unable, proceed to AOMORI VOR/DME at last assigned altitude or 6,000 feet whichever is higher, and execute instrument approach.

(II) Procedures other than above will be issued when situation requires.

3. Category II / III Operations at Aomori Airport

3.1. Facilities

The following facilities are available:

Runway 24
<ul style="list-style-type: none"> • ILS Runway 24-CAT III • Lighting system Runway 24-CAT III • RVR by forward-scatter meters (the touchdown zone, the mid-point and stop-end of the runway)

3.2. Conditions

A. The following systems must be operative:

For ILS RWY 24 approach (CAT II)	For ILS RWY 24 approach (CAT III)
(1) ILS comprising; <ul style="list-style-type: none"> • ILS-LOC 24 with standby transmitter • ILS-GP 24 with standby transmitter (When any standby transmitters unserviceable, downgrade ILS-CAT I.) • IM24 (When IM unserviceable, RA could be used as an alternate method) • ILS-DME 24 	(1) ILS comprising; <ul style="list-style-type: none"> • ILS-LOC 24 with standby transmitter(including far field monitor) • ILS-GP 24 with standby transmitter (When any standby transmitters or far field monitor unserviceable, downgrade ILS-CAT I.) • ILS-DME 24
(2) Lighting systems comprising; <ul style="list-style-type: none"> • PALS 24 (including side row barrettes) • High INTST REDL • High INTST RTHL • RCLL and RTZL 	(2) Lighting system comprising; <ul style="list-style-type: none"> • PALS 24 (including side row barrettes) • High INTST REDL • High INTST RTHL • RCLL and RTZL
(3) Secondary power supply	(3) Secondary power supply
(4) RVR by forward-scatter meters at the touchdown zone and either (the mid-point or stop-end of the runway).	(4) RVR by forward-scatter meters at the touchdown zone, mid-point and stop-end of the runway.

B. The following information must be currently available:

- 1) Surface wind speed and direction
- 2) RVR

C. ITEM A and/or B are not met, the relevant information will be notified to the pilots as soon as practicable.

3.3. Precision Approach Terrain Chart

See RJSA AD2.24

3.4. Operating Minimum

Approach minima stated in AD2.24(Instrument Approach Chart) are observed.

3.5. LVP

LVP will be available when the following conditions are met:

- a) Ceiling is at or less than 200ft and/or RVR is at or less than 600m.
- b) Facilities listed 1. above are operational.
- c) ILS Critical Area is protected.

In order to protect ILS Critical Area for the succeeding arrival aircraft, an arrival aircraft may be given following instruction by ATC.

"REPORT OUT OF ILS CRITICAL AREA"

The exit taxiway centerline lights are fixed alternate green and yellow inside the ILS Critical Area. If an aircraft is given the above instruction, she is expected to advise the ATC when the taxiway centerline lights change from alternate green and yellow to steady green.

3.6. Approval for CAT II / III Operations

Operators must obtain operational approval from the State of Registry or the State of Operator, as appropriate, to conduct CAT II / III Operations. (See GEN1.5)

3.7. Taxiway available for CAT II / III operations

Exit taxiway: T0 , T5 and the parallel taxiway.

4. LVTO at Aomori Airport

4.1. Facilities

The following facilities are available:

RWY 06	RWY 24
<ul style="list-style-type: none"> • Lighting system RWY 06 for LVTO • RVR by forward-scatter meters (the touchdown zone, the mid-point and stop-end of the runway) 	<ul style="list-style-type: none"> • Lighting system RWY 24 for LVTO • RVR by forward-scatter meters (the touchdown zone, the mid-point and stop-end of the runway)

4.2. Conditions

A. The following systems must be operative:

For LVTO
(1) Lighting system comprising; <ul style="list-style-type: none"> • High INTST REDL • High INTST RENL • RCLL
(2) Secondary power supply

B. The following information must be currently available:

- a) Surface wind speed and direction
- b) RVR or VIS

C. ITEM A and/or B are not met, the relevant information will be notified to the pilots as soon as practicable.

4.3. Operating Minima

Take-off minima stated in AD2.22(TAKE-OFF MINIMA) are observed.

4.4. LVP/LVPD

(1)LVP/LVPD will be available when the following conditions are met:

- a)RVR is at or less than 600m.
- b)Facilities listed 4.1 above are operational.

(2)Taxiway available for LVTO

Entering taxiway: T0 and T5

RJSA AD 2.23 ADDITIONAL INFORMATION

Nil

RJSA AD 2.24 CHARTS RELATED TO AN AERODROME

Aerodrome/Heliport Chart Precision Approach Terrain Chart Standard Departure Chart - Instrument (IWAKI, AOMORI REVERSAL) Standard Departure Chart - Instrument (OHMAR-RNAV) Standard Departure Chart - Instrument (SHIRAKAMI-RNAV) Standard Arrival Chart - Instrument (MELOS) Instrument Approach Chart (ILS Z or LOC Z RWY24 (CAT II and III)) Instrument Approach Chart (ILS Y or LOC Y RWY24 (CAT II and III)) Instrument Approach Chart (VOR RWY24) Instrument Approach Chart (VOR Z RWY06) Instrument Approach Chart (VOR Y RWY06) Instrument Approach Chart (RNP Z RWY24 (AR)) Instrument Approach Chart (RNP Y RWY24 (AR)) Instrument Approach Chart (RNP Z RWY06 (AR)) Instrument Approach Chart (RNP Y RWY06 (AR)) Other Chart (Visual REP) Other Chart (LDG CHART) Other Chart (MVA CHART)
--

RJSA / AOMORI

AD CHART

CHANGE : Strength of TWY N, N-APRON.

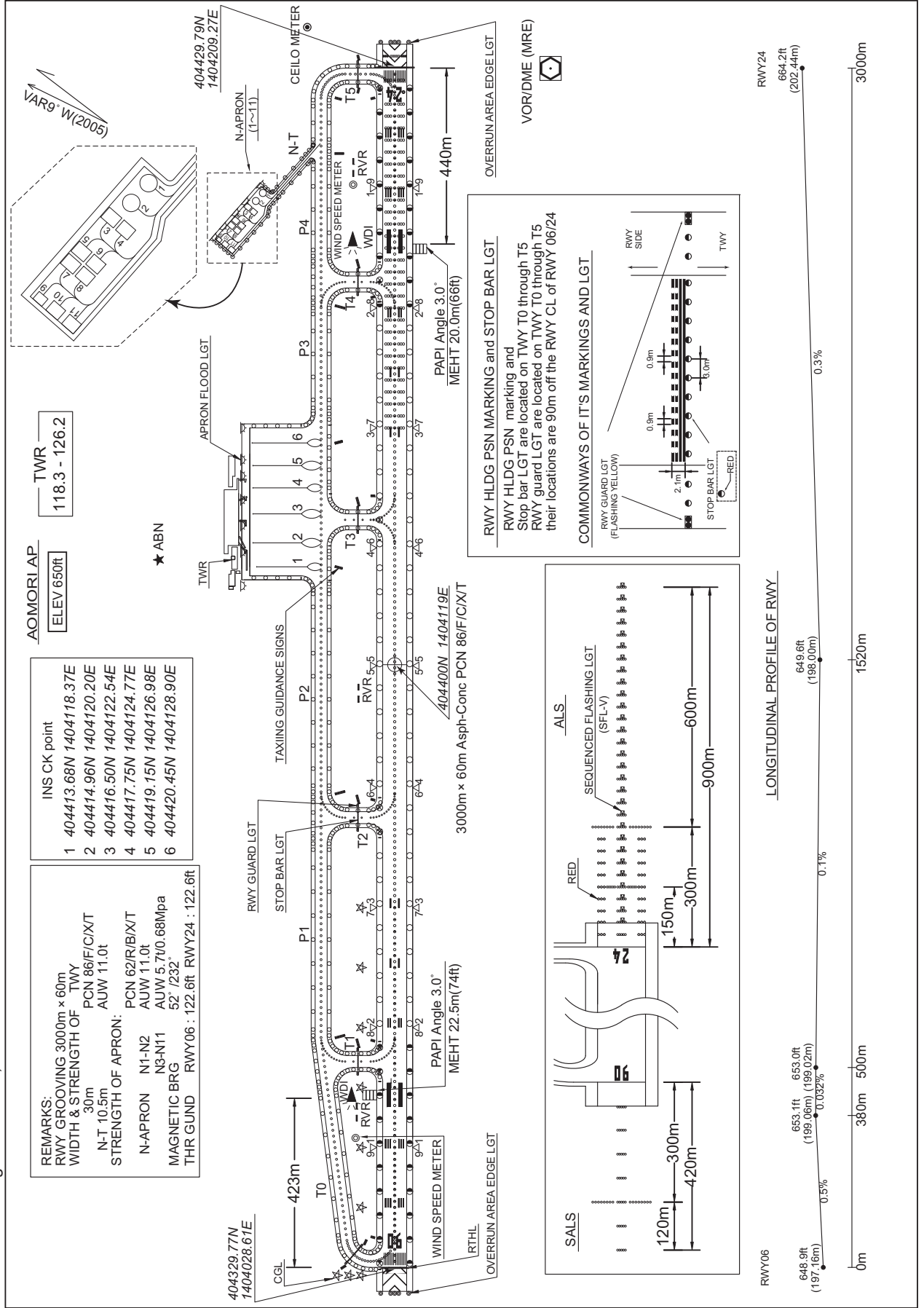

INTENTIONALLY LEFT BLANK

PRECISION APPROACH TERRAIN CHART

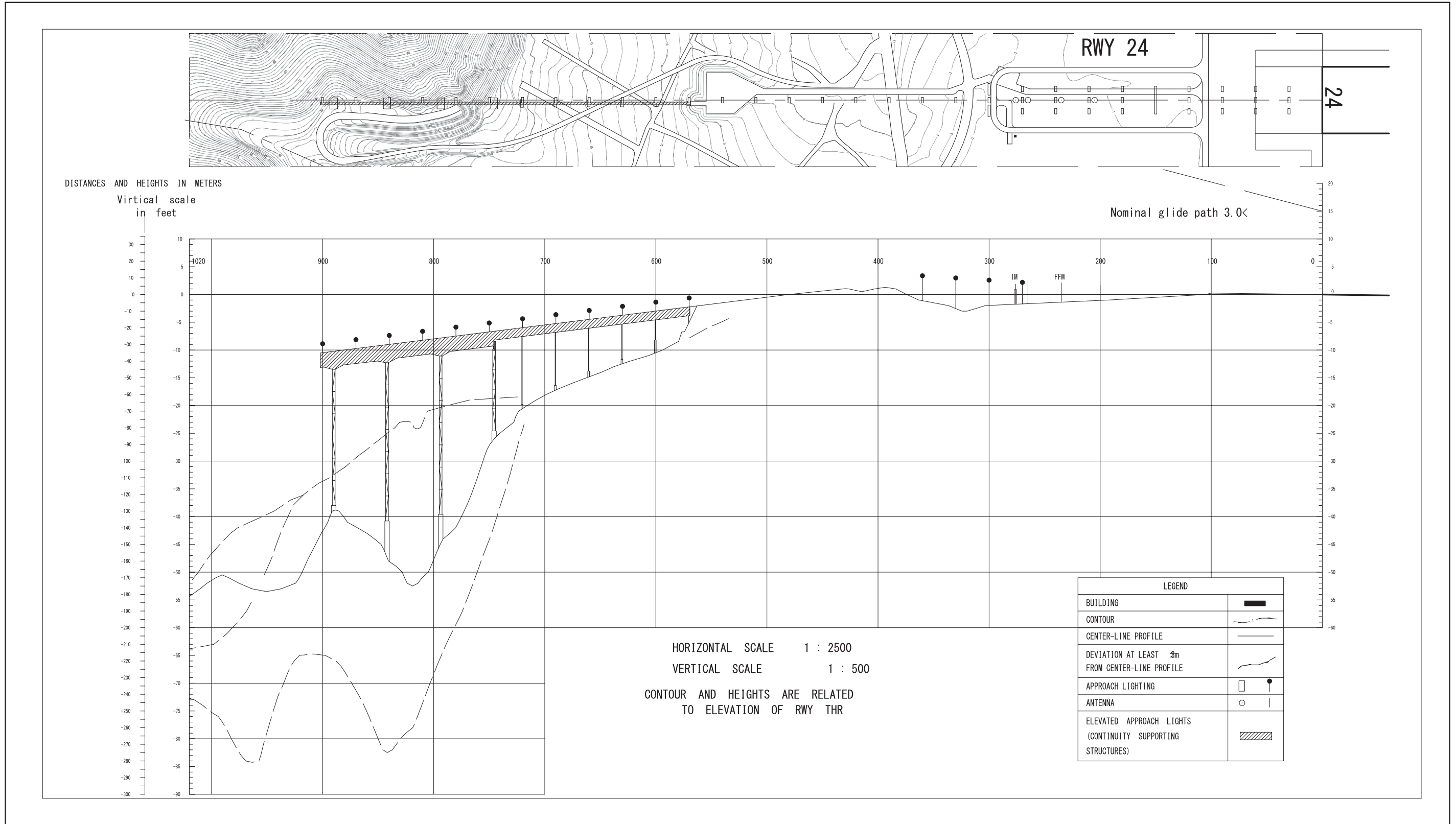

STANDARD DEPARTURE CHART-INSTRUMENT

RJSA / AOMORI

SID and TRANSITION

IWAKI SEVEN DEPARTURE

RWY06 : Climb RWY HDG to 1100FT, turn left HDG 292° to intercept and proceed via MRE R331 to 12.0DME, turn left, via HWE R208 to GONOU.
Cross MRE R331/8.0DME at or above 3600FT, cross HWE R208/63.0DME at or above 7000FT, cross GONOU at or above 9000FT.

RWY24 : Climb RWY HDG to 1200FT, via MRE R239 to GONOU.
Cross GONOU at or above 9000FT.

Note RWY24 : No turn before DER.
5.0% climb gradient required up to 1200FT.
OBST ALT 782FT located at 0.8NM 223° FM end of RWY24.

YUWA TRANSITION

From over GONOU, via UWE R010 to UWE VOR/DME.

NYUDO TRANSITION

From over GONOU, via MRE R239 to NYUDO.
Cross NYUDO at or above FL210.

CHANGE : PROC renamed(IWAKI SEVEN DEPARTURE). PROC course.

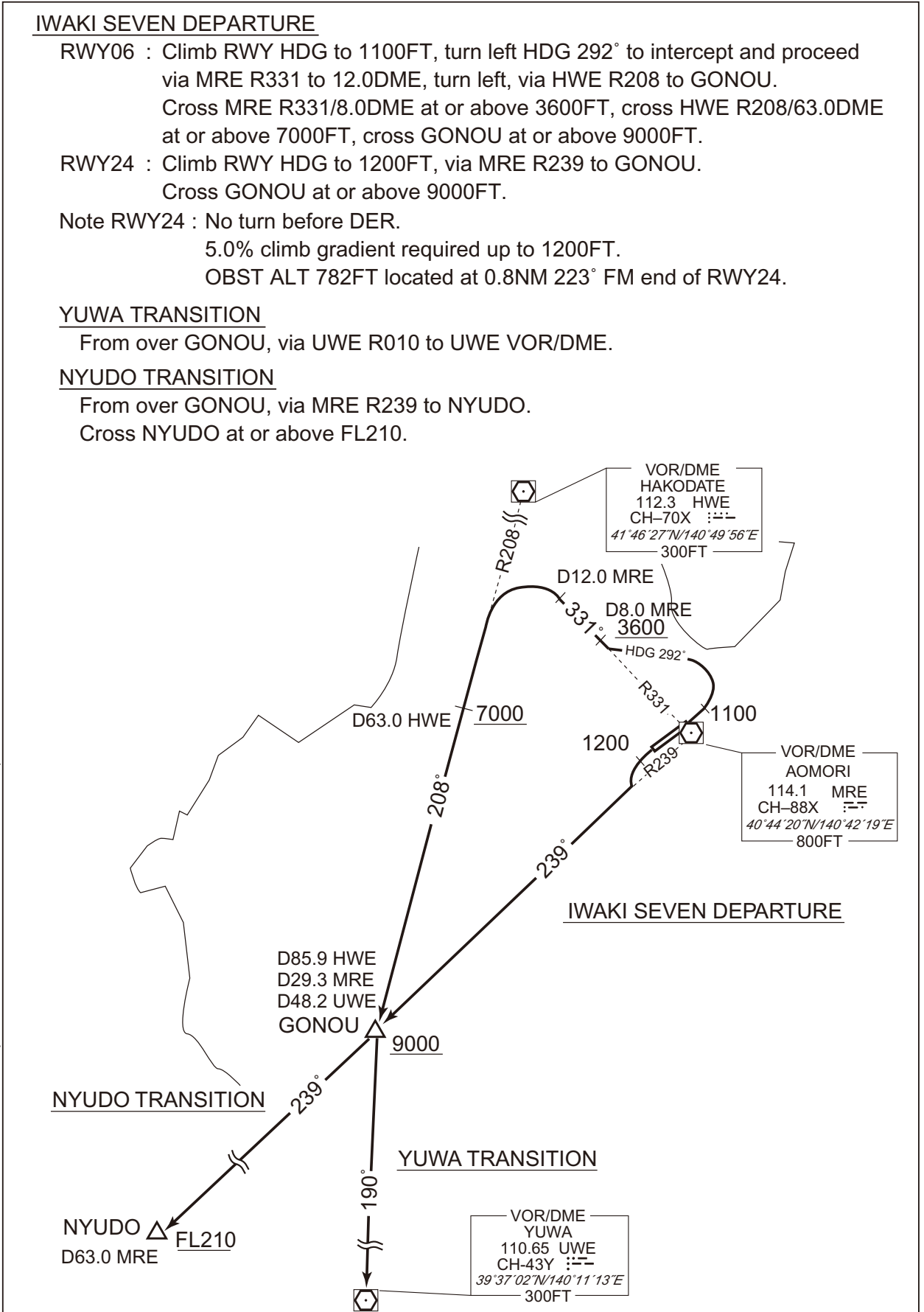

STANDARD DEPARTURE CHART-INSTRUMENT

RJSA / AOMORI

SID

AOMORI REVERSAL THREE DEPARTURE

RWY06 : Climb RWY HDG to 1100FT, turn left HDG 286°...

RWY24 : Climb RWY HDG to 1200FT, turn right HDG 016°...

...to intercept and proceed via MRE R331 to 10.0DME, turn left,
direct to MRE VOR/DME.

Cross MRE R331/8.0DME at or above 3600FT, cross MRE VOR/DME
at or above 6500FT.

Note RWY24 : 5.0% climb gradient required up to 1200FT.

OBST ALT 782FT located at 0.8NM 223° FM end of RWY24.

CHANGE : PROC renamed. PROC course.

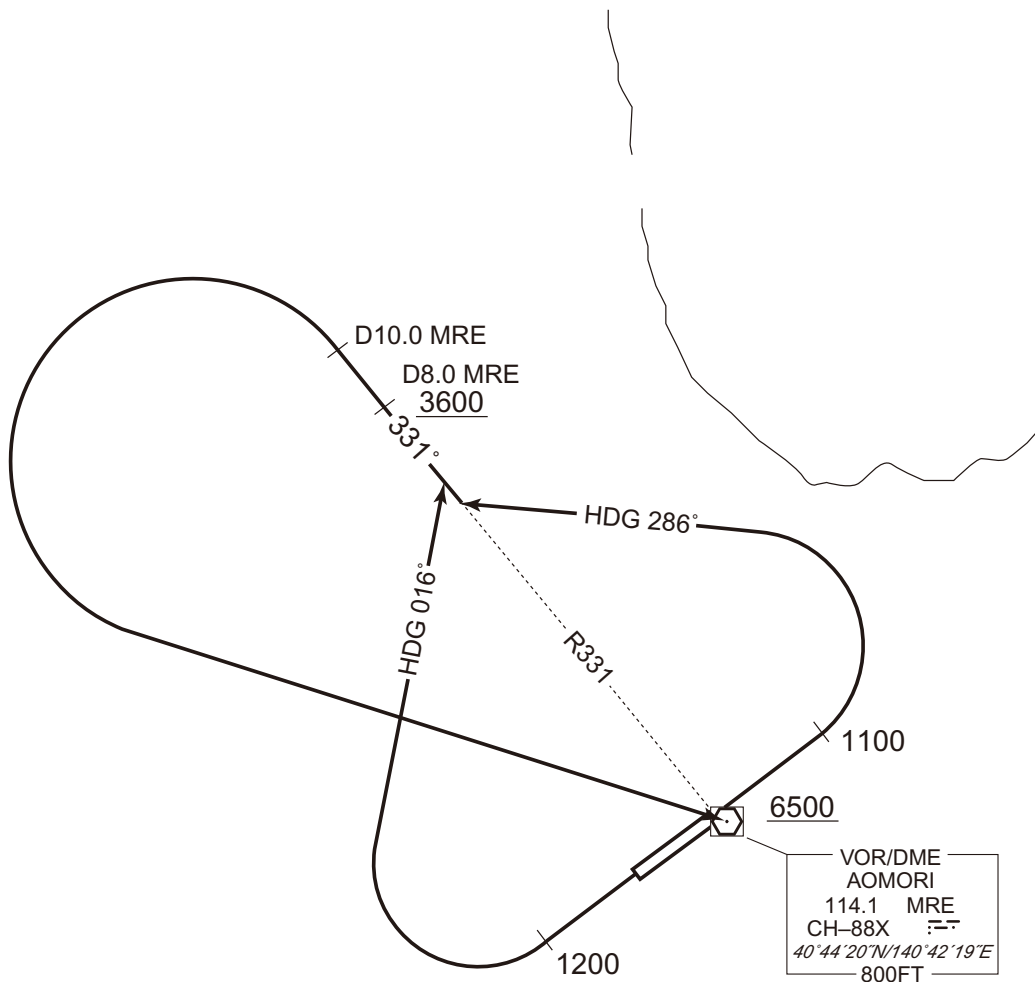

STANDARD DEPARTURE CHART-INSTRUMENT

RJSA / AOMORI

RNAV SID

OHMAR TWO DEPARTURE

RNP1

Note GNSS required.

VAR 9°W

CHANGE : Navigation Specification(Basic RNP1 → RNP1).

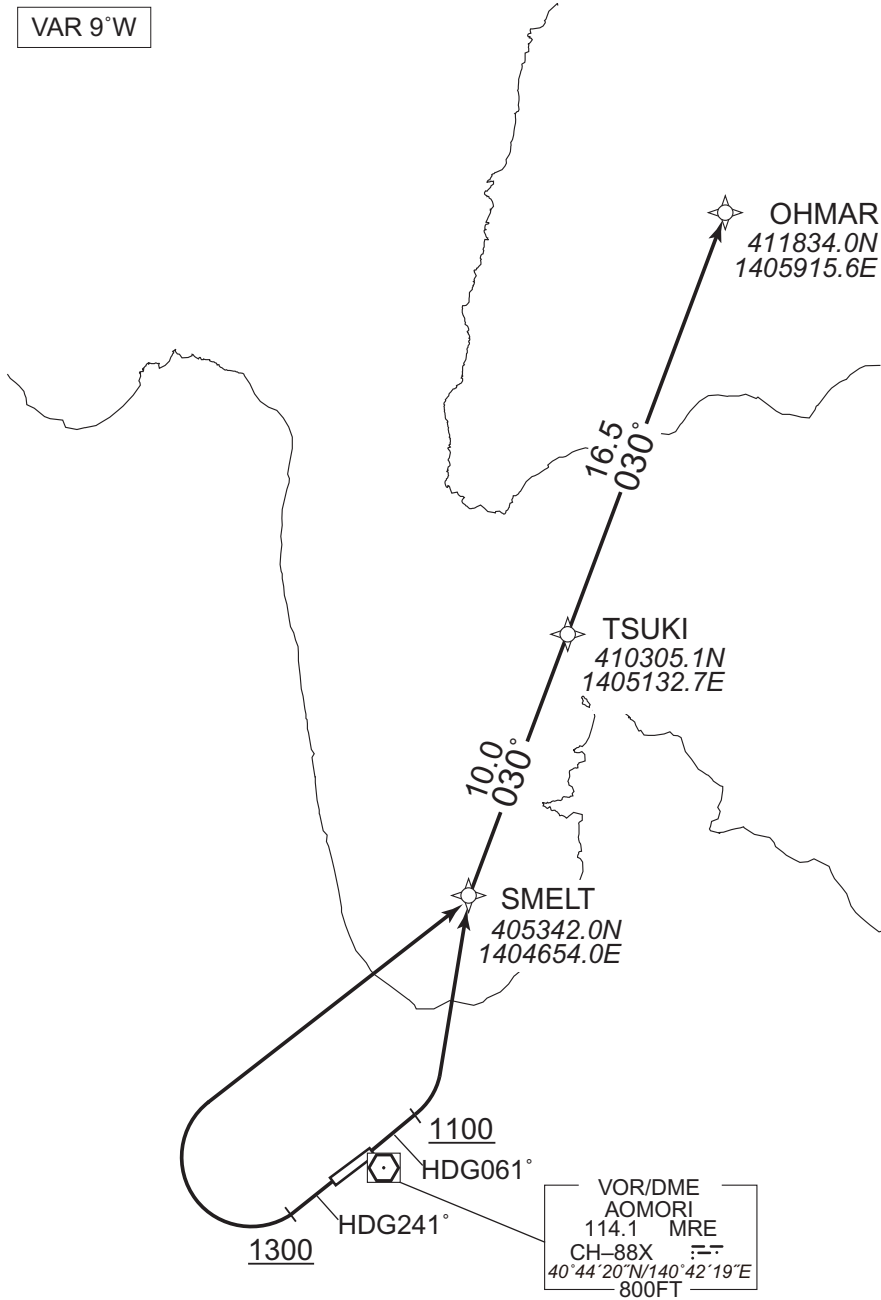

RWY06 : Climb on HDG061° at or above 1100FT, turn left direct to SMELT, to TSUKI, to OHMAR.

RWY24 : Climb on HDG241° at or above 1300FT, turn right direct to SMELT, to TSUKI, to OHMAR.

NOTE RWY24 : 5.0% climb gradient required up to 1300FT.
OBST ALT 782FT located at 0.8NM 223° FM end of RWY24.

STANDARD DEPARTURE CHART-INSTRUMENT

RJSA / AOMORI

RNAV SID

OHMAR TWO DEPARTURE

RWY06

Serial Number	Path Descriptor	Waypoint Identifier	Fly Over	Course °M(°T)	Magnetic Variation	Distance (NM)	Turn Direction	Altitude (FT)	Speed (KIAS)	Vertical Angle	Navigation Specification
001	VA	-	-	061 (051.8)	-9.3	-	-	+1100	-	-	RNP1
002	DF	SMELT	-	-	-9.3	-	L	-	-	-	RNP1
003	TF	TSUKI	-	030 (020.5)	-9.3	10.0	-	-	-	-	RNP1
004	TF	OHMAR	-	030 (020.5)	-9.3	16.5	-	-	-	-	RNP1

RWY24

Serial Number	Path Descriptor	Waypoint Identifier	Fly Over	Course °M(°T)	Magnetic Variation	Distance (NM)	Turn Direction	Altitude (FT)	Speed (KIAS)	Vertical Angle	Navigation Specification
001	VA	-	-	241 (231.8)	-9.3	-	-	+1300	-	-	RNP1
002	DF	SMELT	-	-	-9.3	-	R	-	-	-	RNP1
003	TF	TSUKI	-	030 (020.5)	-9.3	10.0	-	-	-	-	RNP1
004	TF	OHMAR	-	030 (020.5)	-9.3	16.5	-	-	-	-	RNP1

CHANGE : Navigation Specification(Basic RNP1 → RNP1).

STANDARD DEPARTURE CHART-INSTRUMENT

RJSA / AOMORI

RNAV SID

SHIRAKAMI TWO DEPARTURE

RNP1

Note GNSS required.

VAR 9°W

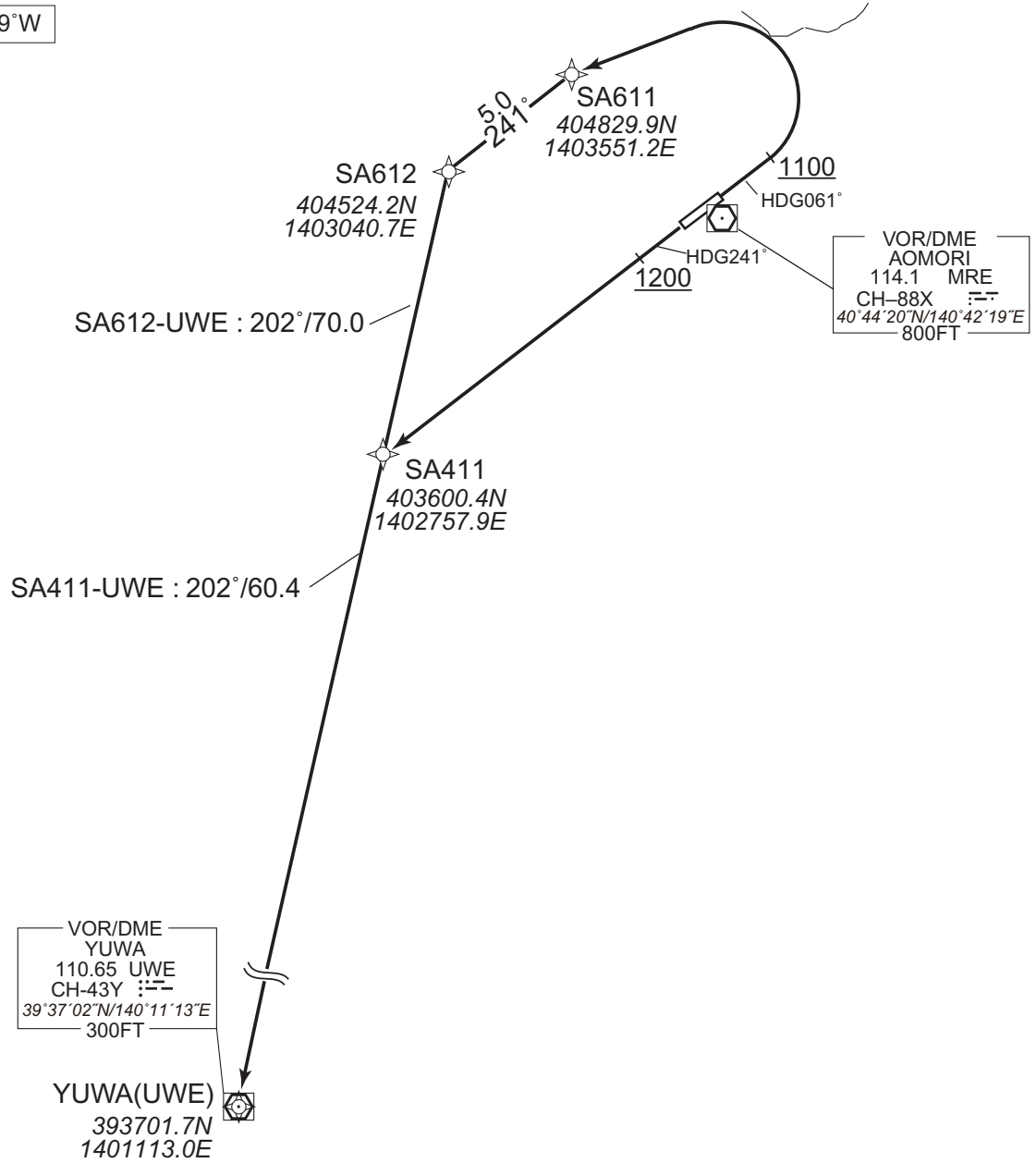

CHANGE : Navigation Specification(Basic RNP1 → RNP1).

- RWY06 : Climb on HDG061° at or above 1100FT, turn left direct to SA611, to SA612, to UWE.
- RWY24 : Climb on HDG241° at or above 1200FT, direct to SA411, to UWE.
- NOTE RWY24 : 5.0% climb gradient required up to 1200FT.
OBST ALT 782FT located at 0.8NM 223° FM end of RWY24.

STANDARD DEPARTURE CHART-INSTRUMENT

RJSA / AOMORI

RNAV SID

SHIRAKAMI TWO DEPARTURE

RWY06

Serial Number	Path Descriptor	Waypoint Identifier	Fly Over	Course °M(°T)	Magnetic Variation	Distance (NM)	Turn Direction	Altitude (FT)	Speed (KIAS)	Vertical Angle	Navigation Specification
001	VA	-	-	061 (051.8)	-9.3	-	-	+1100	-	-	RNP1
002	DF	SA611	-	-	-9.3	-	L	-	-	-	RNP1
003	TF	SA612	-	241 (231.7)	-9.3	5.0	-	-	-	-	RNP1
004	TF	UWE	-	202 (192.4)	-9.3	70.0	-	-	-	-	RNP1

RWY24

Serial Number	Path Descriptor	Waypoint Identifier	Fly Over	Course °M(°T)	Magnetic Variation	Distance (NM)	Turn Direction	Altitude (FT)	Speed (KIAS)	Vertical Angle	Navigation Specification
001	VA	-	-	241 (231.8)	-9.3	-	-	+1200	-	-	RNP1
002	DF	SA411	-	-	-9.3	-	-	-	-	-	RNP1
003	TF	UWE	-	202 (192.3)	-9.3	60.4	-	-	-	-	RNP1

CHANGE : Navigation Specification(Basic RNP1 → RNP1).

STANDARD ARRIVAL CHART-INSTRUMENT

RJSA / AOMORI

STAR

MELOS NORTH ARRIVAL

From over BYOBU, proceed via MRE 12.0DME counterclockwise ARC to MELOS via GOLUS.
Cross GOLUS at or above 5100FT, cross MELOS at or above 3300FT.

MELOS SOUTH ARRIVAL

From over YACHI, proceed via MRE 12.0DME clockwise ARC to MELOS.
Cross MRE R216 at or above 4200FT.
Cross MELOS at or above 3300FT.

CHANGE : PROC course(MELOS NORTH ARRIVAL). GOLUS established.

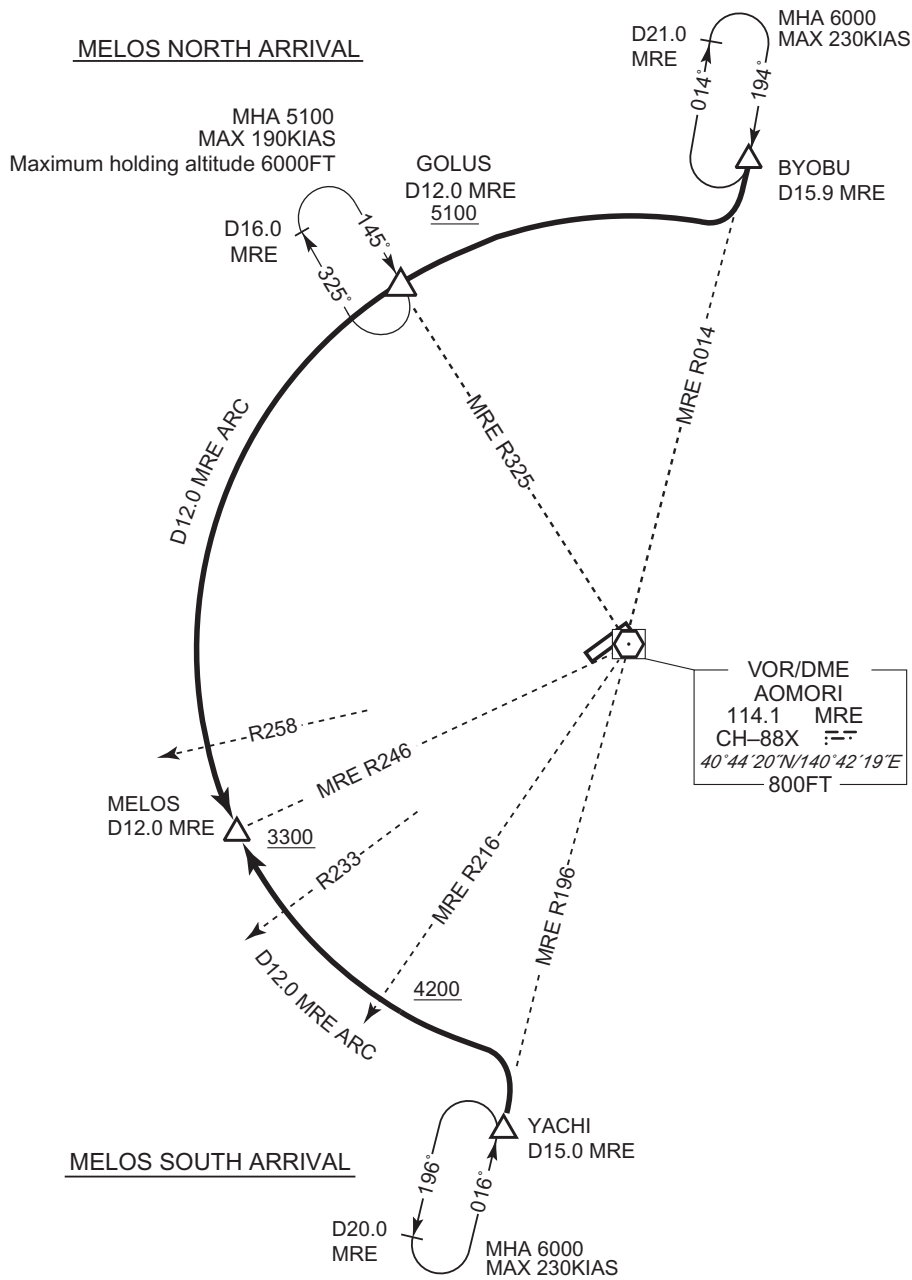

INTENTIONALLY LEFT BLANK

INSTRUMENT APPROACH CHART

RJSA / AOMORI

ILS Z or LOC Z RWY24 (CAT II & III)

SHIRAKAMI APP 119.25 - 315.3 - 120.65	ILS-LOC 111.9 IMR ILS-GP 331.1 ILS-DME CH-56X	AOMORI TOWER 118.3 - 126.2	RADAR AVBL
--	--	-------------------------------	------------

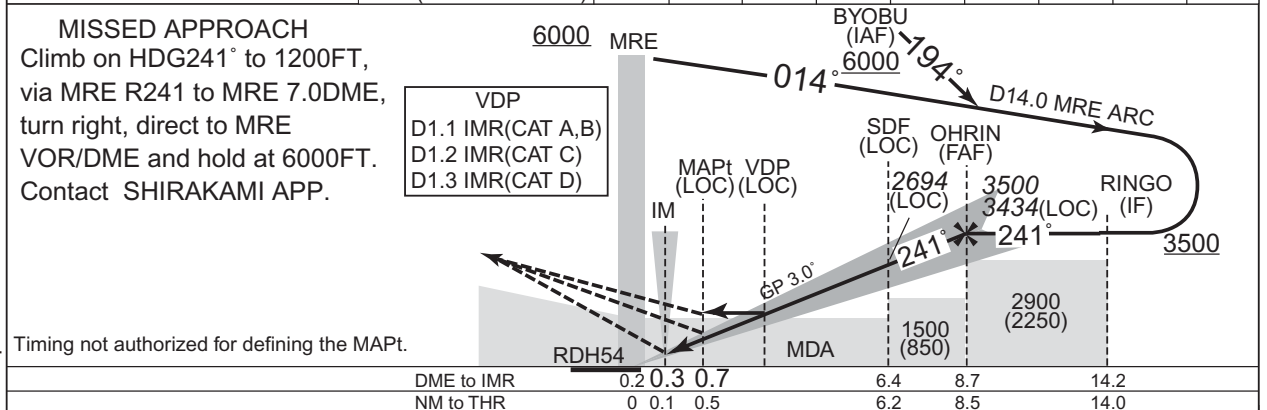
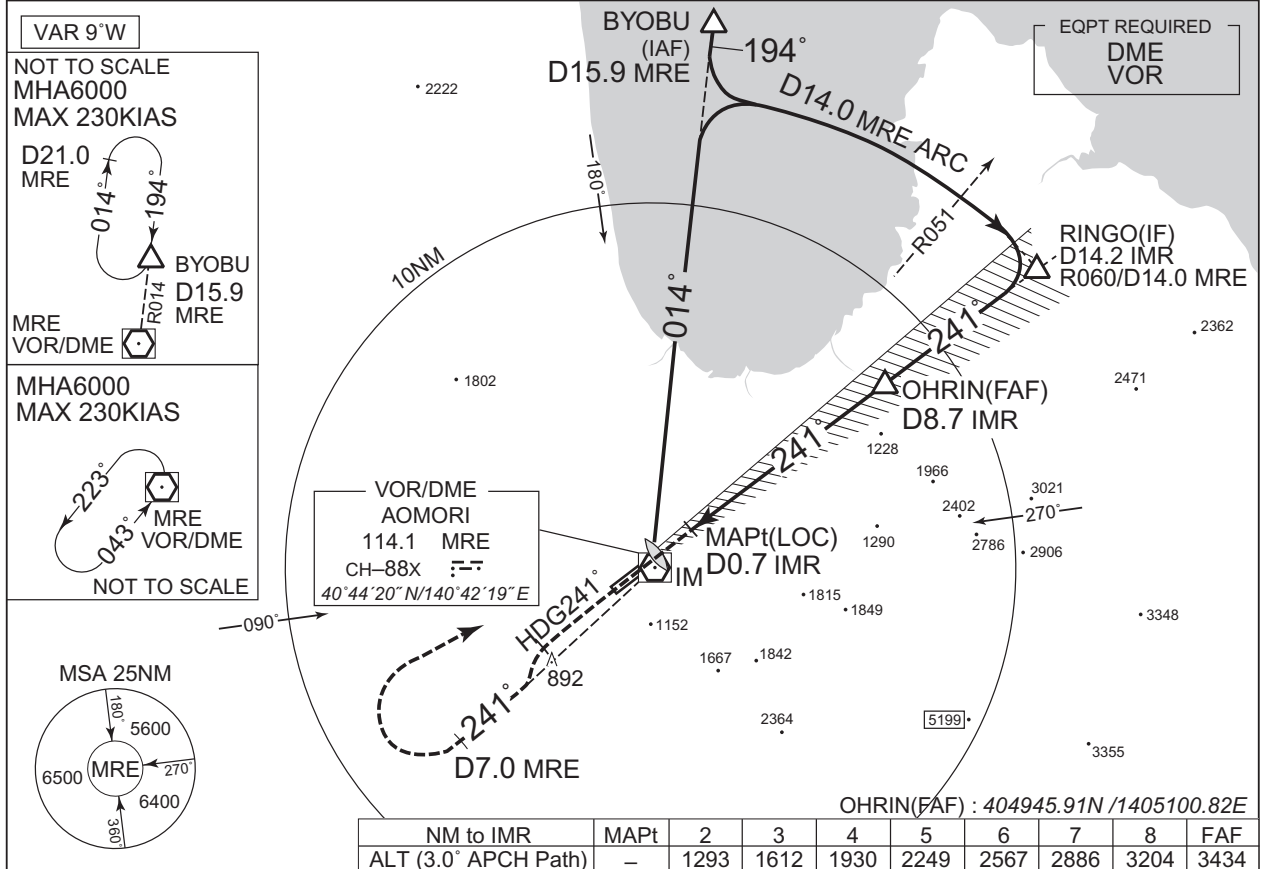

Missed APCH climb gradient MNM 4.0%

MINIMA THR elev. 664 AD elev. 650

CAT	CAT III			CAT II		CAT I		LOC		CIRCLING	
	RVR	DA(DH)	RA	RVR	DA(H)	RVR/CMV	MDA(H)	RVR/CMV	MDA(H)	VIS	
A							990 (340)	900	1220 (570)	1600	
B	100	764 (100)	92	300	864 (200)	550	1010 (360)	1000			
C							1030 (380)				
D							1050 (400)				

MINIMA with Missed APCH climb gradient of 2.5% are not established.
Circling to NORTH side of RWY only.

CHANGE : ATC call sign and FREQ. Description of RADAR Service. Missed APCH PROC.

INSTRUMENT APPROACH CHART

RJSA / AOMORI

ILS Y or LOC Y RWY24 (CAT II & III)

SHIRAKAMI APP 119.25 - 315.3 - 120.65	ILS-LOC 111.9 IMR ILS-GP 331.1 ILS-DME CH-56X	AOMORI TOWER 118.3 - 126.2	RADAR AVBL
--	--	-------------------------------	------------

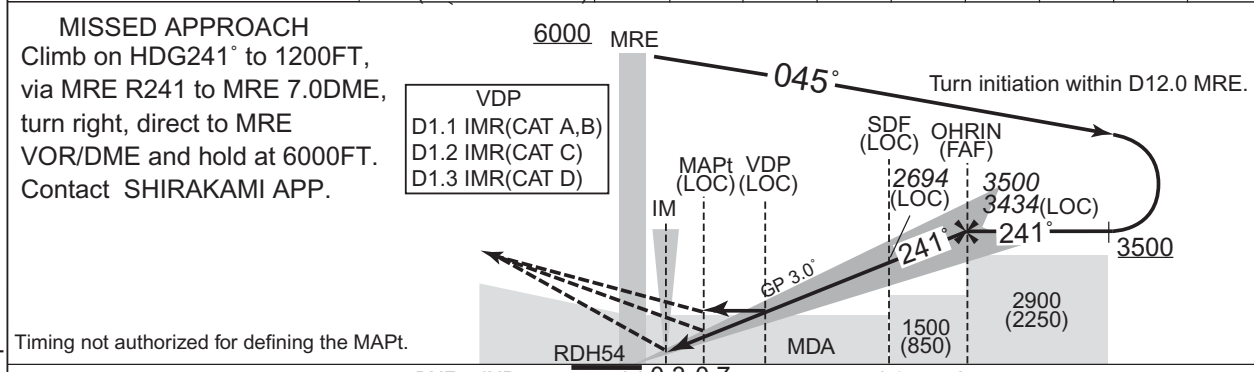
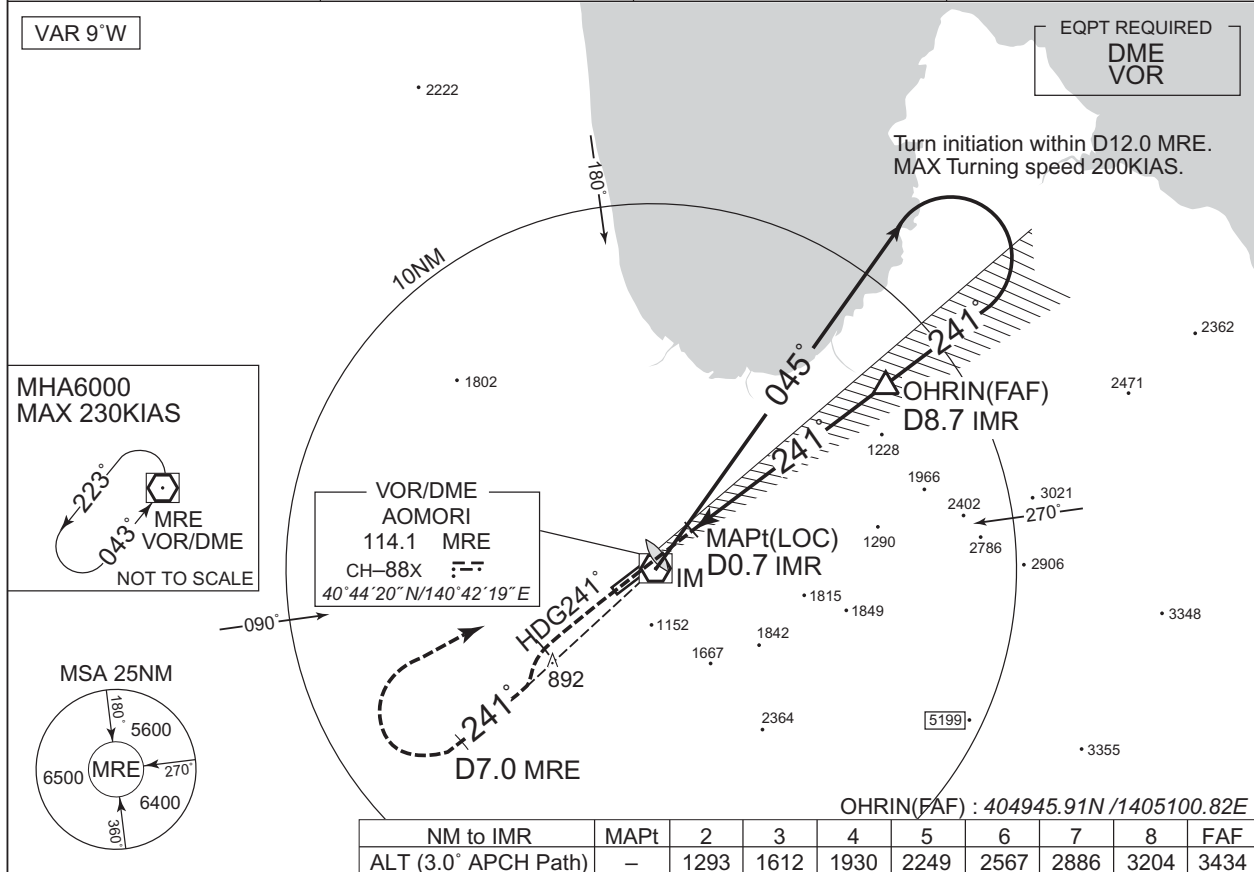

DME to IMR	0.2 0.3 0.7	6.4	8.7
NM to THR	0 0.1 0.5	6.2	8.5

Missed APCH climb gradient MNM 4.0%

MINIMA		THR elev. 664			AD elev. 650					
CAT	CAT III	CAT II		CAT I		LOC		CIRCLING		
	RVR	DA(DH)	RA	RVR	DA(H)	RVR/CMV	MDA(H)	RVR/CMV	MDA(H)	VIS
A							990 (340)	900		
B	100	764 (100)	92	300	864 (200)	550	1010 (360)	1000	1220 (570)	1600
C							1030 (380)			
D							1050 (400)	1400		

MINIMA with Missed APCH climb gradient of 2.5% are not established.
Circling to NORTH side of RWY only.

CHANGE : ATC call sign and FREQ. Description of RADAR Service. Missed APCH PROC.

INSTRUMENT APPROACH CHART

RJSA / AOMORI VOR RWY24

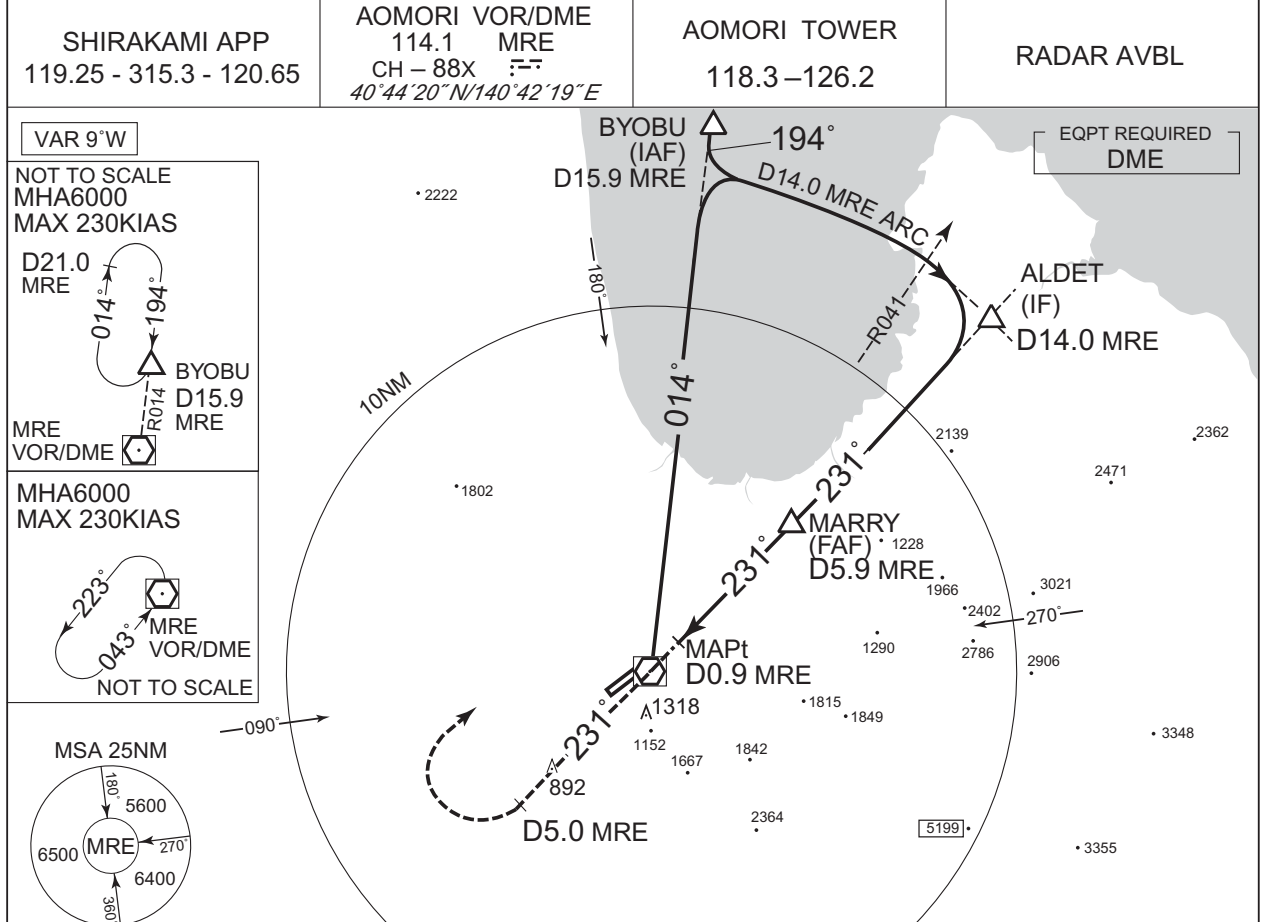

CHANGE : ATC call sign and FREQ. Description of RADAR Service. Missed APCH PROC.

MARRY(FAF) : 404842.24N /1404733.47E

MISSED APPROACH

Climb to 6000FT via MRE
R231 to MRE 5.0DME, turn right, direct to MRE VOR/DME and hold.
Contact SHIRAKAMI APP.

DME to MRE	0	0.9	5.9	9.2	14.0
NM to THR	0	0.9	5.9	9.2	14.0

Missed APCH climb gradient MNM 5.0%				
MINIMA		THR elev. 664	AD elev. 650	
CAT	MDA(H)		CIRCLING	
	MDA(H)	RVR/CMV	MDA(H)	VIS
A	990 (340)	900	1220 (570)	1600
B	1030 (380)	1000		2400
C	1070 (420)	1600		3200
D	1110 (460)	1600		

MINIMA with Missed APCH climb gradient of 2.5% are not established.
Circling to NORTH side of RWY only.

INSTRUMENT APPROACH CHART

RJSA / AOMORI

VOR Z RWY06

SHIRAKAMI APP 119.25 - 315.3 - 120.65	AOMORI VOR/DME 114.1 MRE CH - 88X 40°44'20"N/140°42'19"E	AOMORI TOWER 118.3 - 126.2	RADAR AVBL
--	---	-------------------------------	------------

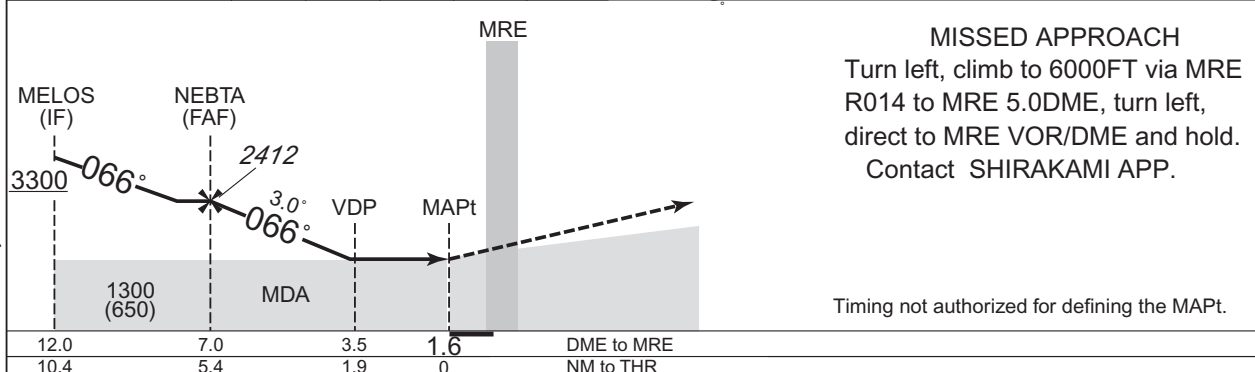
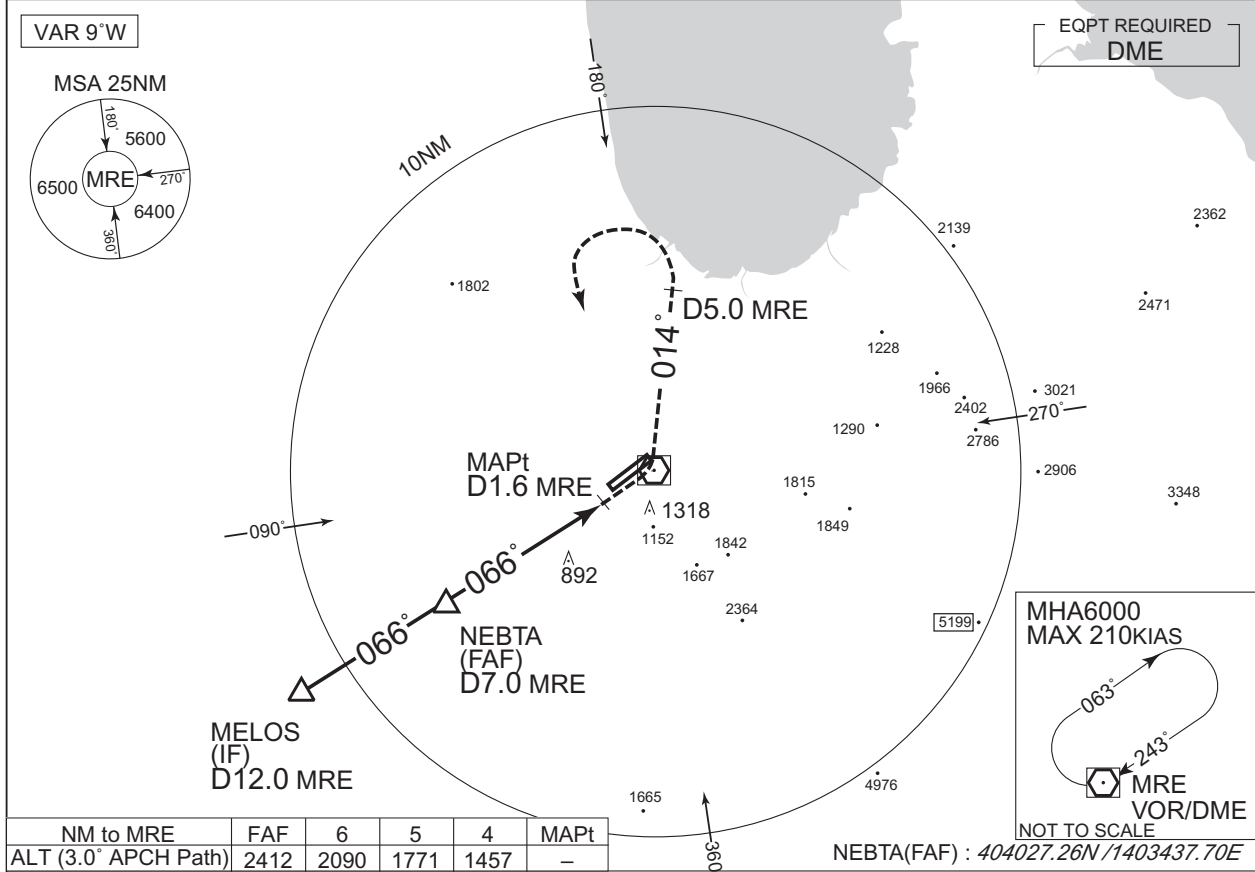

MINIMA		THR elev. 647	AD elev. 650
CAT	MDA(H)		CIRCLING
	RVR/CMV	MDA(H)	VIS
A	1300 (650)	1500	1600
B			
C		1800	2400
D			

Circling to NORTH side of RWY only.

CHANGE : ATC call sign and FREQ. Description of RADAR Service. Missed APCH PROC.

INSTRUMENT APPROACH CHART

RJSA / AOMORI

VOR Y RWY06

SHIRAKAMI APP 119.25 - 315.3 - 120.65	AOMORI VOR/DME 114.1 MRE CH - 88X 40°44'20"N/140°42'19"E	AOMORI TOWER 118.3 - 126.2	RADAR AVBL
--	---	-------------------------------	------------

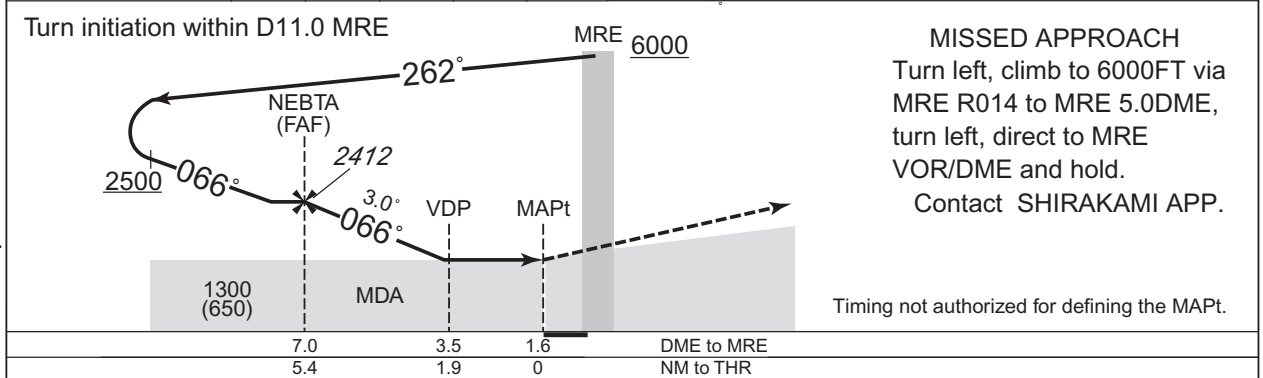
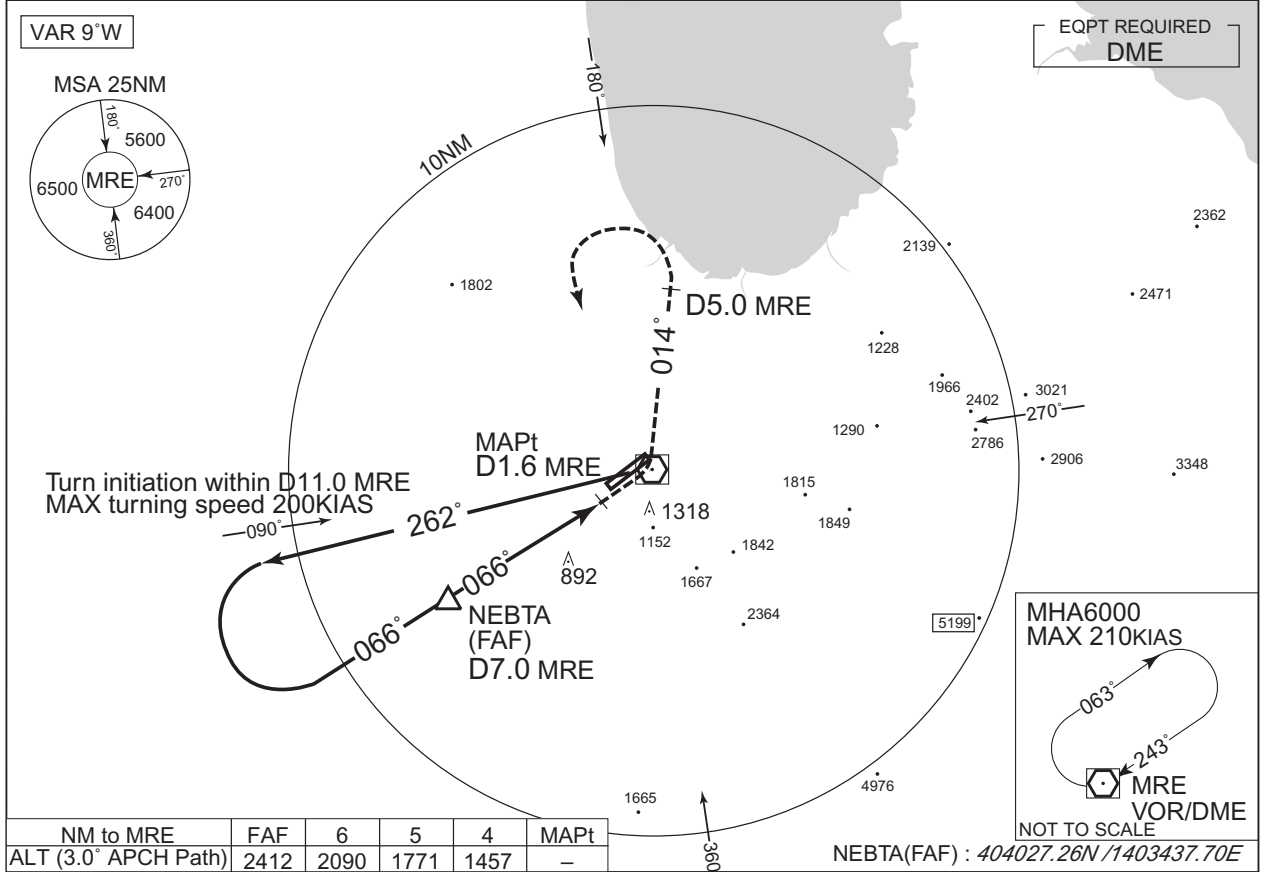

MINIMA		THR elev. 647	AD elev. 650	
CAT	CIRCLING			
	MDA(H)	RVR/CMV	MDA(H)	VIS
A	1300 (650)	1500	1300 (650)	1600
B				2400
C				2400
D				3200

Circling to NORTH side of RWY only.

CHANGE : ATC call sign and FREQ. Description of RADAR Service. Missed APCH PROC.

INSTRUMENT APPROACH CHART

RJSA / AOMORI

RNP Z RWY24(AR)

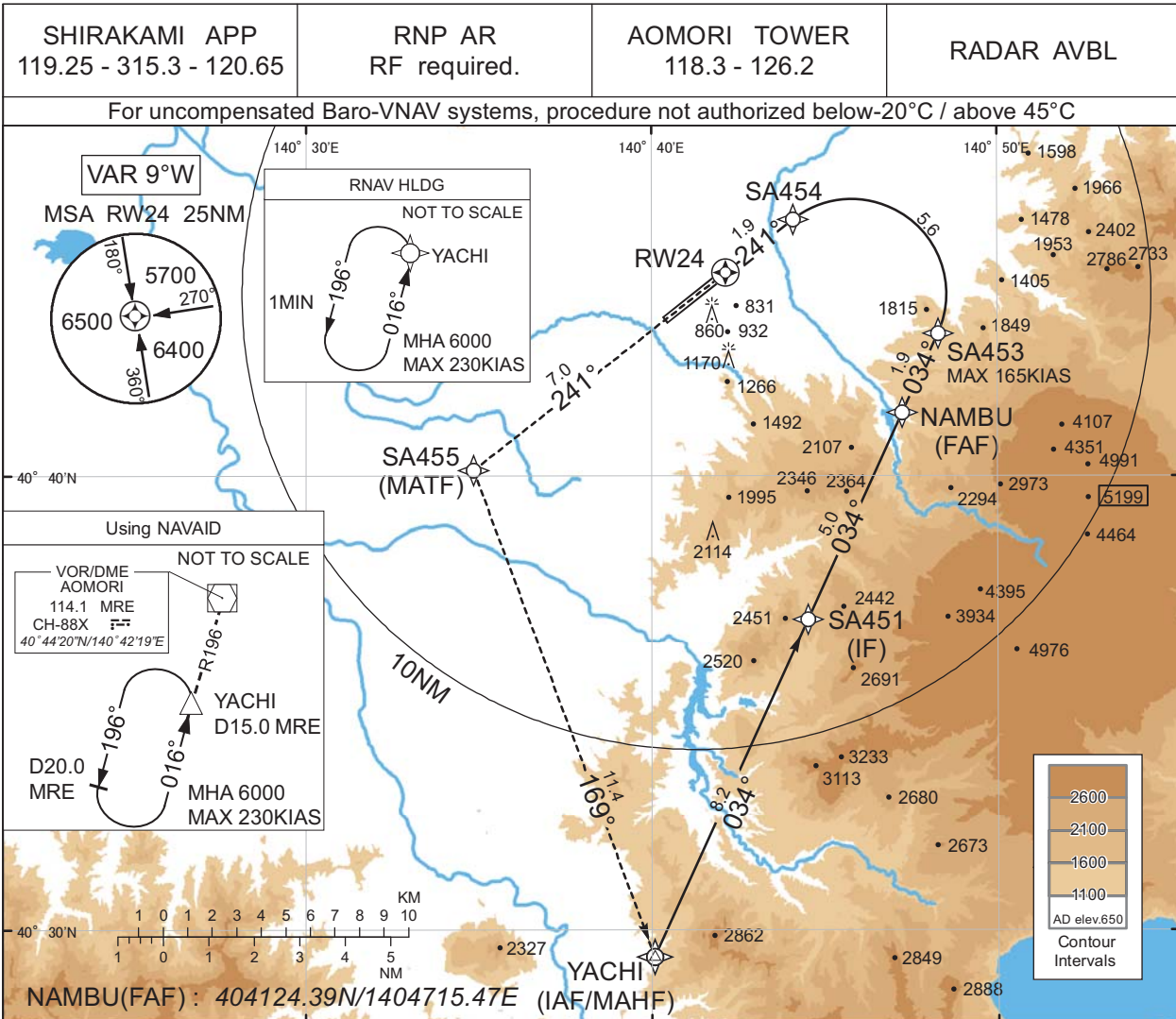

MISSED APPROACH

Climb to 6000FT, to SA455, to YACHI and hold.
Contact SHIRAKAMI APP.

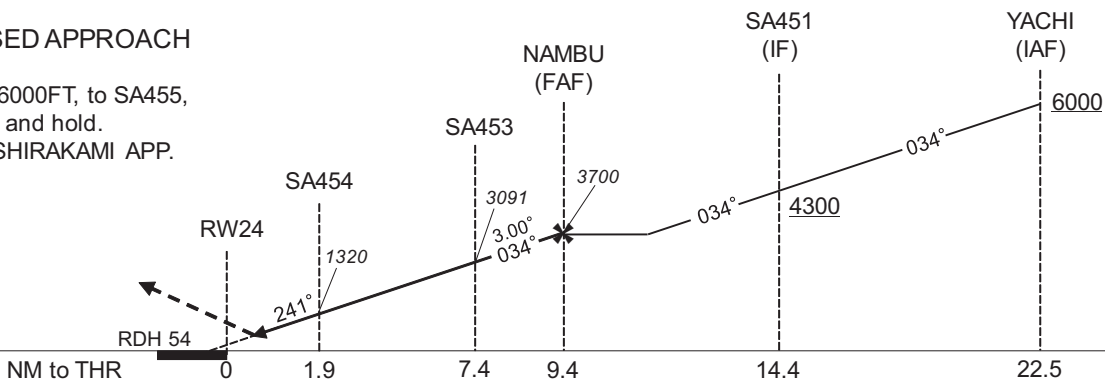

Missed APCH climb gradient MNM 5.0%

CAT	THR elev. 664		AD elev. 650	
	RNP 0.10		RNP 0.30	
	DA(H)	RVR/CMV	DA(H)	RVR/CMV
A	-	-	-	-
B	-	-	-	-
C	984(320)	1000	1063(399)	1000
D	994(330)	1400	1073(409)	1400

MINIMA with Missed APCH climb gradient of 2.5% are not established.

Authorization Required

CHANGE : ATC call sign and FREQ. Description of RADAR Service. Missed APCH PROC.

INSTRUMENT APPROACH CHART

RJSA / AOMORI

RNP Z RWY24(AR)

Coding Table

Serial Number	Path Descriptor	Waypoint Identifier	Fly Over	Course °M(°T)	Magnetic Variation	Distance (NM)	Turn Direction	Altitude (FT)	Speed (KIAS)	VPA/ RDH (°/FT)	RNP Value
001	IF	YACHI	-	-	-9.3	-	-	+6000	-	-	-
002	TF	SA451	-	034 (024.4)	-9.3	8.2	-	+4300	-	-	1.0
003	TF	NAMBU	-	034 (024.5)	-9.3	5.0	-	3700	-	-	1.0
004	TF	SA453	-	034 (024.5)	-9.3	1.9	-	3091	-165	-3.00	0.10 0.30
005	RF Center: SARF1 r=2.09NM	SA454	-	-	-9.3	5.6	L	1320	-	-3.00	0.10 0.30
006	TF	RW24	Y	241 (231.8)	-9.3	1.9	-	718	-	-3.00/54	0.10 0.30
007	TF	SA455	-	241 (231.8)	-9.3	7.0	-	-	-	-	1.0
008	TF	YACHI	-	169 (159.7)	-9.3	11.4	-	6000	-	-	1.0

Path	Waypoint Identifier	Inbound Course °M(°T)	Magnetic Variation	Outbound Time (MIN)	Turn Direction	Minimum Altitude (FT)	Maximum Altitude (FT)	Speed (KIAS)	RNP Value
Hold	YACHI	016 (006.5)	-9.3	1.0 (-14000)	L	6000	FL140	-230 (-14000)	1.0

Waypoint Coordinates

Waypoint Identifier	Coordinates	RF Arc Center Identifier	Coordinates
YACHI	402925.44N / 1404004.97E	SARF1	404400.99N / 1404548.34E
SA451	403651.24N / 1404431.58E		
NAMBU	404124.39N / 1404715.47E		
SA453	404308.85N / 1404818.25E		
SA454	404539.74N / 1404406.71E		
RW24	404429.79N / 1404209.27E		
SA455	404008.45N / 1403451.64E		

CHANGE : PROC course. VAR. RNAV HLDG established(YACHI).

INSTRUMENT APPROACH CHART

RJSA / AOMORI

RNP Y RWY24(AR)

SHIRAKAMI APP 119.25 - 315.3 - 120.65	RNP AR RF required.	AOMORI TOWER 118.3 - 126.2	RADAR AVBL
--	------------------------	-------------------------------	------------

For uncompensated Baro-VNAV systems, procedure not authorized below -20°C / above 45°C

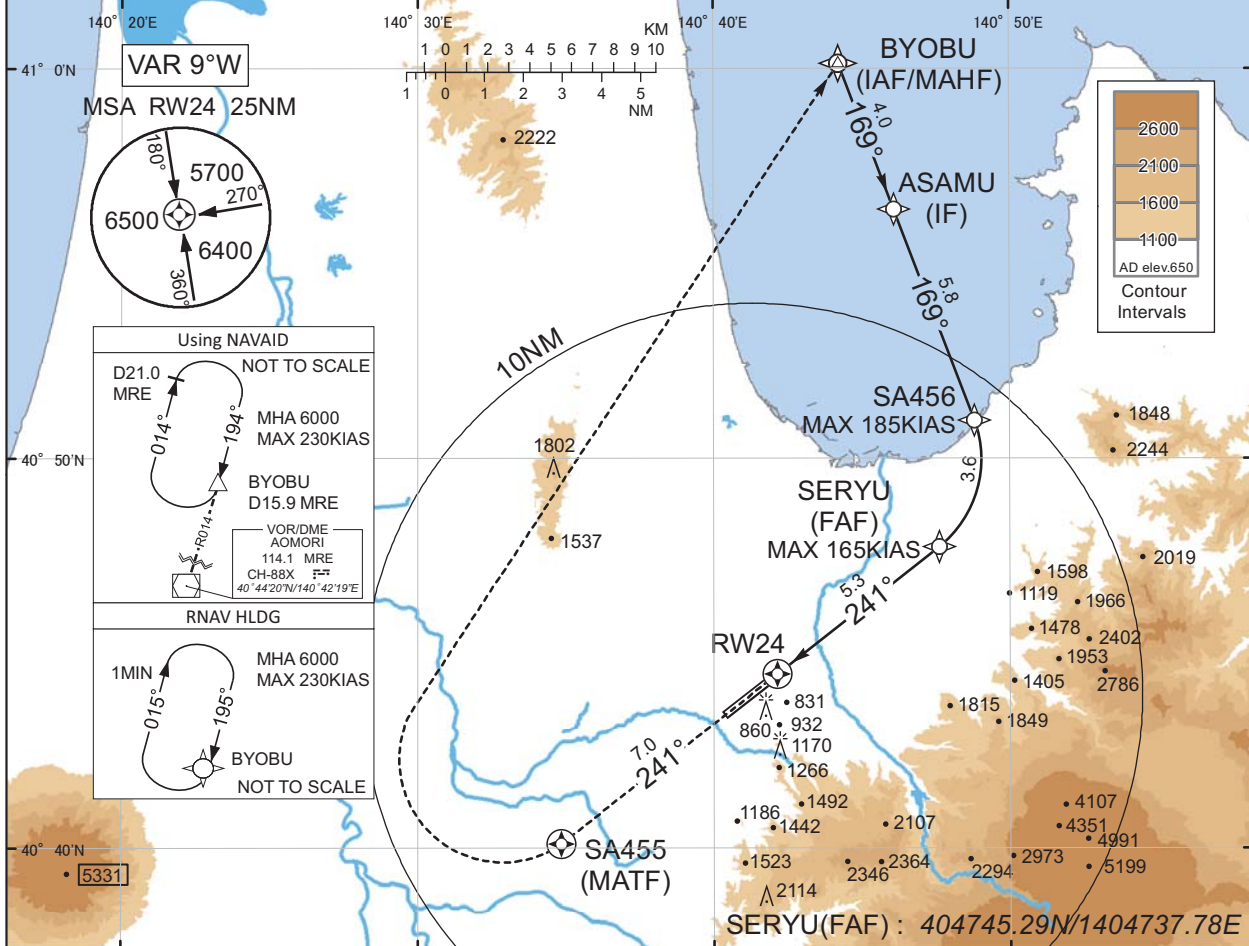

MISSED APPROACH

To SA455 on track 241°, turn right direct to BYOBU and hold at 6000FT. Contact SHIRAKAMI APP.

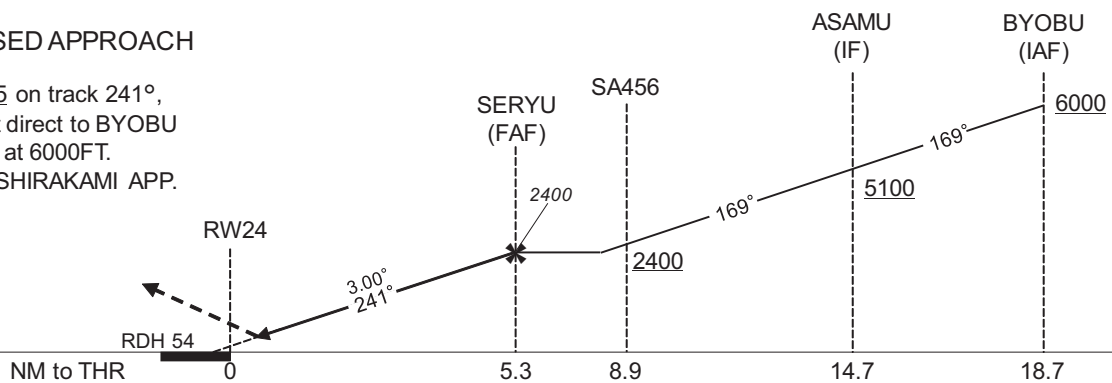

Missed APCH climb gradient MNM 5.0%

MINIMA	THR elev. 664		AD elev. 650	
CAT	RNP 0.10		RNP 0.30	
	DA(H)	RVR/CMV	DA(H)	RVR/CMV
A	-	-	-	-
B	-	-	-	-
C	984(320)	1000	1063(399)	1000
D	994(330)	1400	1073(409)	1400

MINIMA with Missed APCH climb gradient of 2.5% are not established.

Authorization Required

CHANGE : ATC call sign and FREQ. Description of RADAR Service. Missed APCH PROC.

INSTRUMENT APPROACH CHART

RJSA / AOMORI

RNP Y RWY24(AR)

Coding Table

Serial Number	Path Descriptor	Waypoint Identifier	Fly Over	Course °M(°T)	Magnetic Variation	Distance (NM)	Turn Direction	Altitude (FT)	Speed (KIAS)	VPA/ RDH (°/FT)	RNP Value
001	IF	BYOBU	-	-	-9.3	-	-	+6000	-	-	-
002	TF	ASAMU	-	169 (159.3)	-9.3	4.0	-	+5100	-	-	1.0
003	TF	SA456	-	169 (159.3)	-9.3	5.8	-	+2400	-185	-	0.3
004	RF Center: SARF3 r=2.83NM	SERYU	-	-	-9.3	3.6	R	2400	-165	-	0.3
005	TF	RW24	Y	241 (231.9)	-9.3	5.3	-	718	-	-3.00/54	0.10 0.30
006	CF	SA455	Y	241 (231.8)	-9.3	7.0	-	-	-	-	1.0
007	DF	BYOBU	-	-	-9.3	-	R	6000	-	-	1.0

Path	Waypoint Identifier	Inbound Course °M(°T)	Magnetic Variation	Outbound Time (MIN)	Turn Direction	Minimum Altitude (FT)	Maximum Altitude (FT)	Speed (KIAS)	RNP Value
Hold	BYOBU	195 (185.2)	-9.3	1.0 (-14000)	R	6000	FL140	-230 (-14000)	1.0

Waypoint Coordinates

Waypoint Identifier	Coordinates	RF Arc Center Identifier	Coordinates
BYOBU	410009.54N / 1404414.25E	SARF3	404959.39N / 1404519.70E
ASAMU	405624.95N / 1404606.79E		
SA456	405059.78N / 1404849.32E		
SERYU	404745.29N / 1404737.78E		
RW24	404429.79N / 1404209.27E		
SA455	404008.45N / 1403451.64E		

CHANGE : PROC course. VAR. RNAV HLDG established(BYOBU).

INSTRUMENT APPROACH CHART

RJSA / AOMORI

RNP Z RWY06(AR)

SHIRAKAMI APP 119.25 - 315.3 - 120.65	RNP AR RF required.	AOMORI TOWER 118.3 - 126.2	RADAR AVBL
--	------------------------	-------------------------------	------------

For uncompensated Baro-VNAV systems, procedure not authorized below -20°C / above 45°C

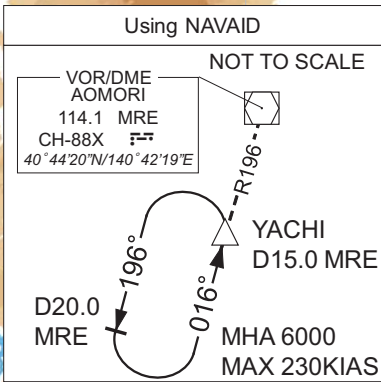
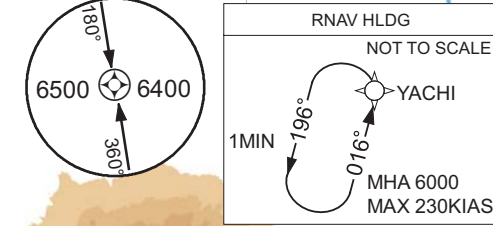
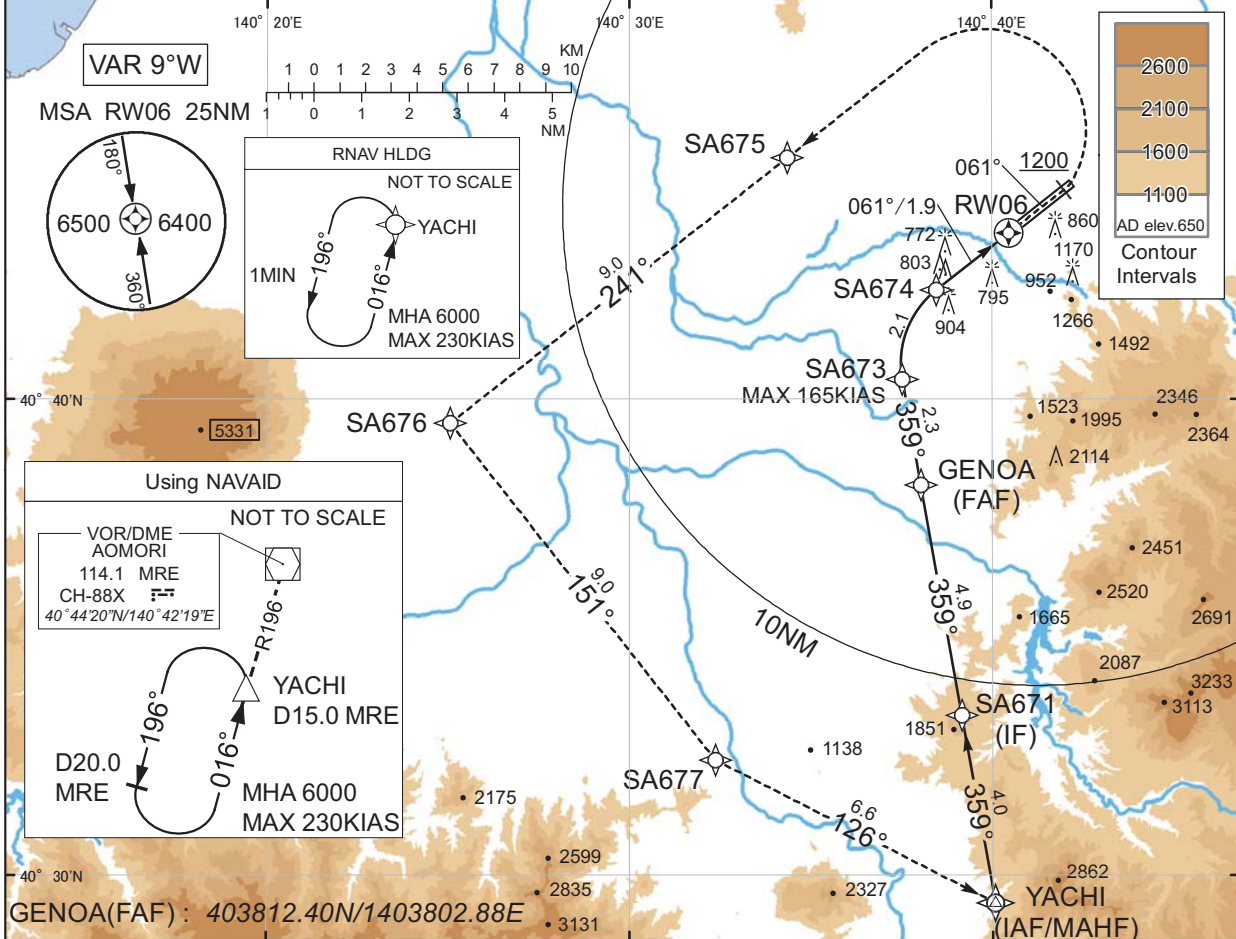

GENOA (FAF) : 403812.40N/1403802.88E

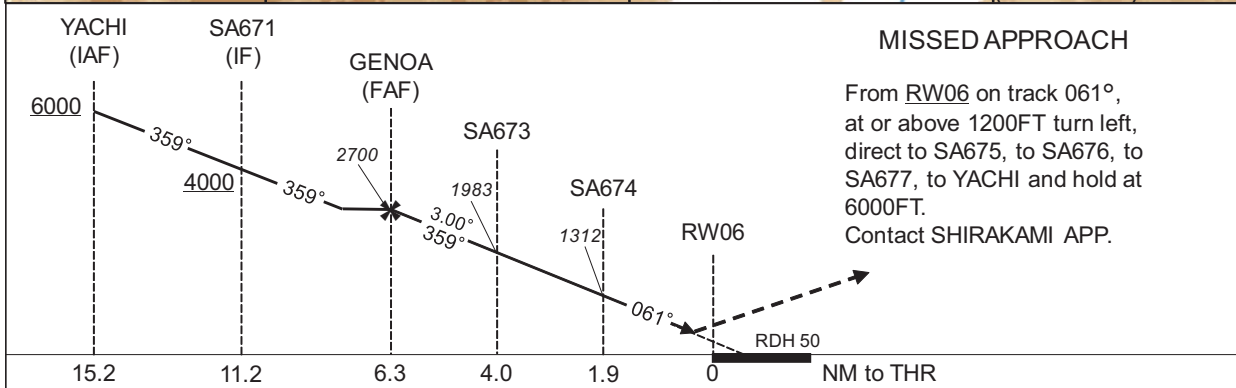

MISSED APPROACH

From RW06 on track 061°, at or above 1200FT turn left, direct to SA675, to SA676, to SA677, to YACHI and hold at 6000FT. Contact SHIRAKAMI APP.

Missed APCH climb gradient MNM 5.0%

CAT	RNP 0.10		RNP 0.30	
	DA(H)	RVR/CMV	DA(H)	RVR/CMV
A	-	-	-	-
B	-	-	-	-
C	1004(357)	1400	1039(392)	1400
D	1014(367)	1600	1049(402)	1600

MINIMA with Missed APCH climb gradient of 2.5% are not established.

Authorization Required

CHANGE : ATC call sign and FREQ. Description of RADAR Service. Missed APCH PROC.

INSTRUMENT APPROACH CHART

RJSA / AOMORI

RNP Z RWY06(AR)

Coding Table

Serial Number	Path Descriptor	Waypoint Identifier	Fly Over	Course °M(°T)	Magnetic Variation	Distance (NM)	Turn Direction	Altitude (FT)	Speed (KIAS)	VPA/RDH (°/FT)	RNP Value
001	IF	YACHI	-	-	-9.3	-	-	+6000	-	-	-
002	TF	SA671	-	359 (350.0)	-9.3	4.0	-	+4000	-	-	1.0
003	TF	GENOA	-	359 (350.0)	-9.3	4.9	-	2700	-	-	1.0
004	TF	SA673	-	359 (350.0)	-9.3	2.3	-	1983	-165	-3.00	0.10 0.30
005	RF Center: SARF2 r=1.95NM	SA674	-	-	-9.3	2.1	R	1312	-	-3.00	0.10 0.30
006	TF	RW06	Y	061 (051.8)	-9.3	1.9	-	697	-	-3.00/50	0.10 0.30
007	FA	-	-	061 (051.8)	-9.3	-	-	+1200	-	-	1.0
008	DF	SA675	-	-	-9.3	-	L	-	-	-	1.0
009	TF	SA676	-	241 (231.7)	-9.3	9.0	-	-	-	-	1.0
010	TF	SA677	-	151 (141.8)	-9.3	9.0	-	-	-	-	1.0
011	TF	YACHI	-	126 (117.1)	-9.3	6.6	-	6000	-	-	1.0

Path	Waypoint Identifier	Inbound Course °M(°T)	Magnetic Variation	Outbound Time (MIN)	Turn Direction	Minimum Altitude (FT)	Maximum Altitude (FT)	Speed (KIAS)	RNP Value
Hold	YACHI	016 (006.5)	-9.3	1.0 (-14000)	L	6000	FL140	-230 (-14000)	1.0

Waypoint Coordinates

Waypoint Identifier	Coordinates	RF Arc Center Identifier	Coordinates
YACHI	402925.44N / 1404004.97E	SARF2	404045.88N / 1404003.56E
SA671	403322.04N / 1403910.22E		
GENOA	403812.40N / 1403802.88E		
SA673	404025.48N / 1403731.96E		
SA674	404218.09N / 1403828.52E		
RW06	404329.77N / 1404028.61E		
SA675	404504.89N / 1403421.94E		
SA676	403930.44N / 1402503.91E		
SA677	403225.82N / 1403222.79E		

CHANGE : VAR. RNAV HLDG established(YACHI).

INSTRUMENT APPROACH CHART

RJSA / AOMORI

RNP Y RWY06(AR)

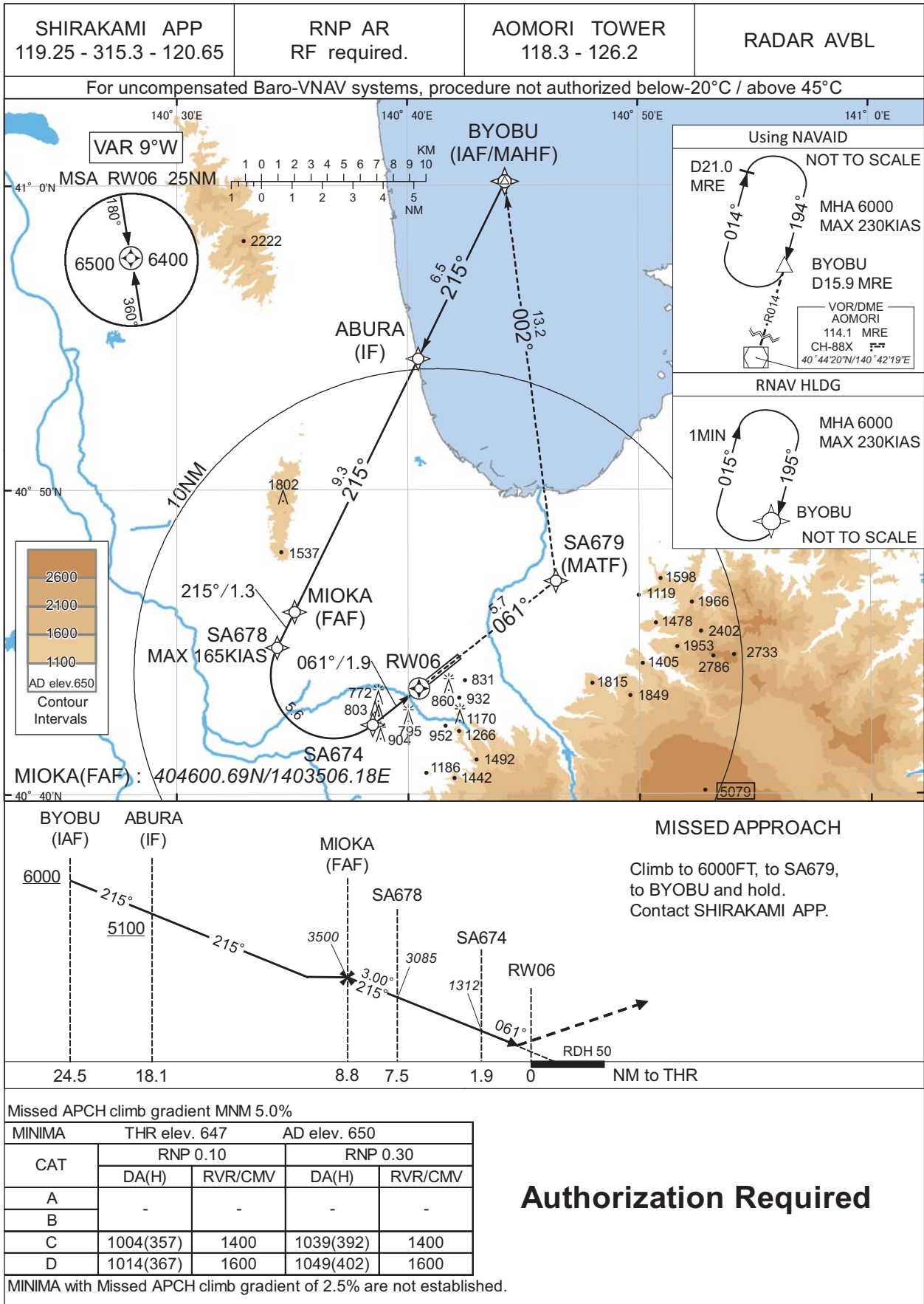

CHANGE : ATC call sign and FREQ. Description of RADAR Service. Missed APCH PROC.

Authorization Required

INSTRUMENT APPROACH CHART

RJSA / AOMORI

RNP Y RWY06(AR)

Coding Table

Serial Number	Path Descriptor	Waypoint Identifier	Fly Over	Course °M(°T)	Magnetic Variation	Distance (NM)	Turn Direction	Altitude (FT)	Speed (KIAS)	VPA/ RDH (°/FT)	RNP Value
001	IF	BYOBU	-	-	-9.3	-	-	+6000	-	-	-
002	TF	ABURA	-	215 (206.1)	-9.3	6.5	-	+5100	-	-	1.0
003	TF	MIOKA	-	215 (206.0)	-9.3	9.3	-	3500	-	-	1.0
004	TF	SA678	-	215 (206.0)	-9.3	1.3	-	3085	-165	-3.00	0.10 0.30
005	RF Center: SARF4 r=2.07NM	SA674	-	-	-9.3	5.6	L	1312	-	-3.00	0.10 0.30
006	TF	RW06	Y	061 (051.8)	-9.3	1.9	-	697	-	-3.00/50	0.10 0.30
007	TF	SA679	-	061 (051.8)	-9.3	5.7	-	-	-	-	1.0
008	TF	BYOBU	-	002 (352.9)	-9.3	13.2	-	6000	-	-	1.0

Path	Waypoint Identifier	Inbound Course °M(°T)	Magnetic Variation	Outbound Time (MIN)	Turn Direction	Minimum Altitude (FT)	Maximum Altitude (FT)	Speed (KIAS)	RNP Value
Hold	BYOBU	195 (185.2)	-9.3	1.0 (-14000)	R	6000	FL140	-230 (-14000)	1.0

Waypoint Coordinates

Waypoint Identifier	Coordinates	RF Arc Center Identifier	Coordinates
BYOBU	410009.54N / 1404414.25E	SARF4	404355.81N / 1403647.71E
ABURA	405419.99N / 1404028.03E		
MIOKA	404600.69N / 1403506.18E		
SA678	404450.39N / 1403420.99E		
SA674	404218.09N / 1403828.52E		
RW06	404329.77N / 1404028.61E		
SA679	404701.68N / 1404624.34E		

CHANGE : VAR. RNAV HLDG established(BYOBU).

RJSA / AOMORI

Visual REP

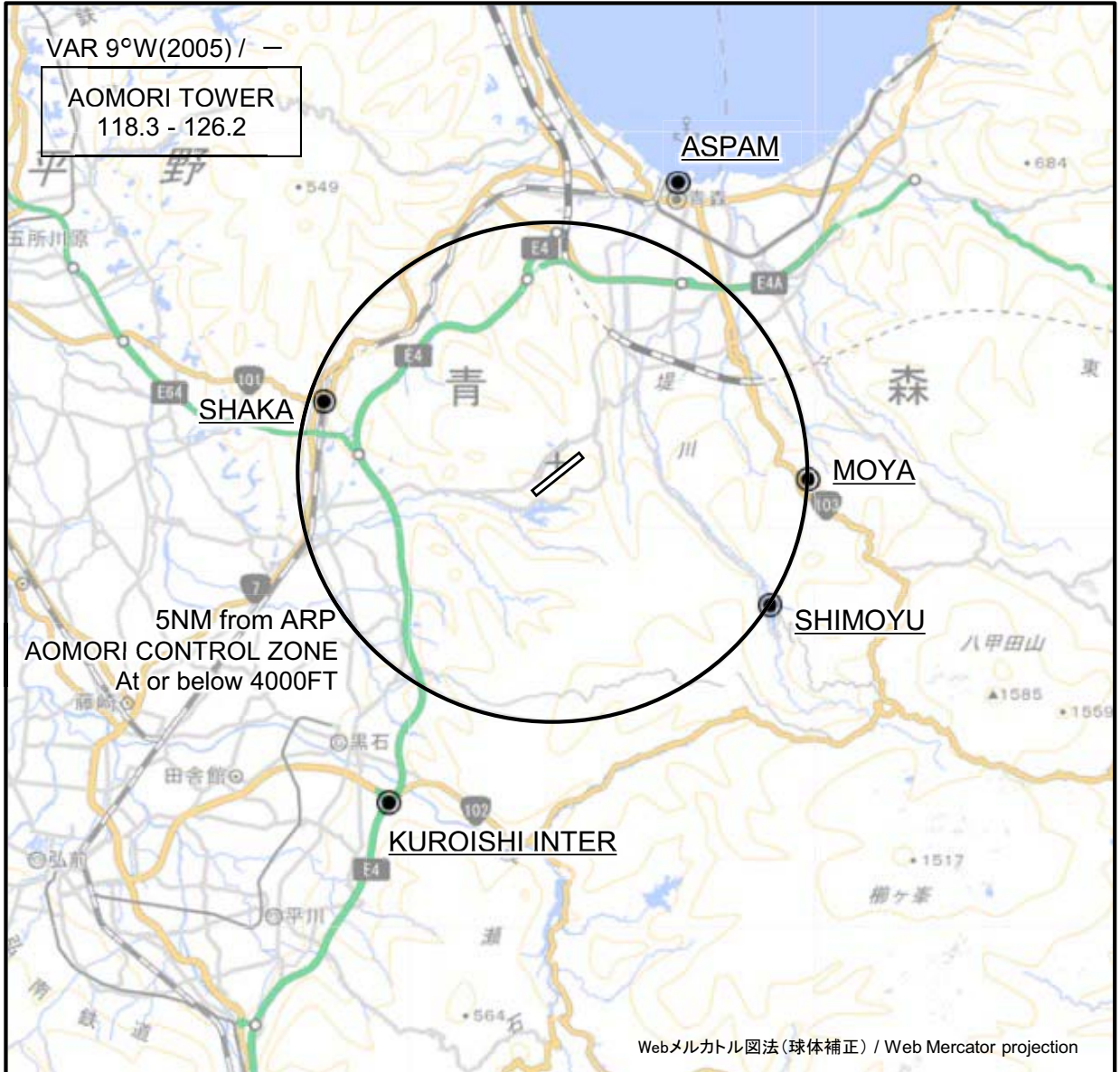

CHANGE : Map updated. BRG/DIST from ARP.

※図中に標高を示す数字がある場合、単位はメートル(m)である。The unit of measurement used to express elevation is meter(m).

Call sign	BRG / DIST from ARP	Remarks
アスパム Aspam	022°T / 6.3NM	アスパム, 三角形のビル ASPAM, Triangular
釈迦 Shaka	287°T / 4.8NM	JR大釈迦駅 JR Station
雲谷 Moya	092°T / 5.0NM	雲谷スキー場 Moya Slope
下湯 Shimoyu	123°T / 5.0NM	下湯平成湖 Lake
黒石インター Kuroishi Inter	206°T / 7.4NM	東北自動車道黒石インター Intersection

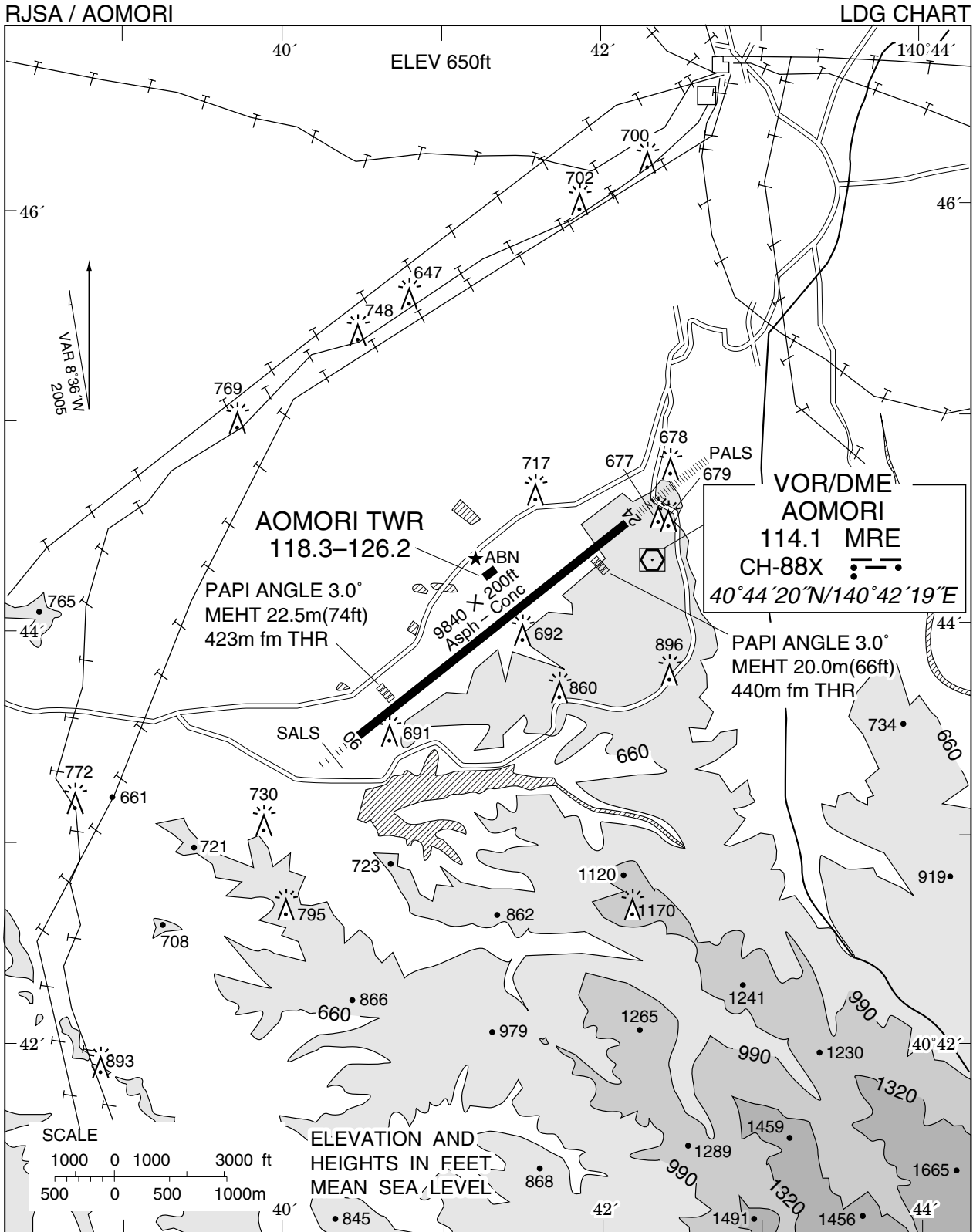

RJSA / AOMORI

Minimum Vectoring Altitude CHART

