

AD 2 AERODROMES

RJSH AD 2.1 AERODROME LOCATION INDICATOR AND NAME

RJSH - HACHINOHE

RJSH AD 2.2 AERODROME GEOGRAPHICAL AND ADMINISTRATIVE DATA

1	ARP coordinates and site at AD	403307N 1412802E
2	Direction and distance from (city)	3.0nm NW
3	Elevation/ Reference temperature	152ft / -
4	Geoid undulation at AD ELEV PSN	Nil
5	MAG VAR/ Annual change	Nil
6	AD Administration, address, telephone, telefax, telex, AFS, e-mail and/or Web-site addresses	JSDF-M
7	Types of traffic permitted(IFR/VFR)	IFR/VFR
8	Remarks	Nil

RJSH AD 2.3 OPERATIONAL HOURS

1	AD Administration	H24
2	Customs and immigration	Nil
3	Health and sanitation	Nil
4	AIS Briefing Office	H24
5	ATS Reporting Office(ARO)	Nil
6	MET Briefing Office	H24
7	ATS	H24
8	Fuelling	Nil
9	Handling	Nil
10	Security	Nil
11	De-icing	Nil
12	Remarks	Nil

RJSB AD 2.4 HANDLING SERVICES AND FACILITIES

1	Cargo-handling facilities	Nil
2	Fuel/ oil types	JET A-1 PLUS
3	Fuelling facilities/ capacity	To be issued later
4	De-icing facilities	Nil
5	Hangar space for visiting aircraft	Nil
6	Repair facilities for visiting aircraft	Nil
7	Remarks	Nil

RJSB AD 2.5 PASSENGER FACILITIES

1	Hotels	Nil
2	Restaurants	Nil
3	Transportation	Nil
4	Medical facilities	Nil
5	Bank and Post Office	Nil
6	Tourist Office	Nil
7	Remarks	Nil

RJSB AD 2.6 RESCUE AND FIRE FIGHTING SERVICES

1	AD category for fire fighting	Nil
2	Rescue equipment	Nil
3	Capability for removal of disabled aircraft	Nil
4	Remarks	Nil

RJSB AD 2.7 SEASONAL AVAILABILITY-CLEARING

1	Types of clearing equipment	Nil
2	Clearance priorities	Nil
3	Remarks	Nil

RJSH AD 2.8 APRONS, TAXIWAYS AND CHECK LOCATIONS DATA

1	Apron surface and strength	To be issued later
2	Taxiway width, surface and strength	To be issued later
3	ACL and elevation	Not available
4	VOR checkpoints	Nil
5	INS checkpoints	Nil
6	Remarks	Nil

RJSH AD 2.9 SURFACE MOVEMENT GUIDANCE AND CONTROL SYSTEM AND MARKINGS

1	Use of aircraft stand ID signs, TWY guide lines and Visual docking/ parking guidance system of aircraft stands	Nil
2	RWY and TWY markings and LGT	RWY: 07/25 (LGT) RTHL, TKOF aiming LGT TWY: (LGT) TWY edge LGT
3	Stop bars	Nil
4	Remarks	Nil

RJSH AD 2.10 AERODROME OBSTACLES

RWY/Area affected	Obstacle type	Coordinates	Elevation	Markings/ LGT	Remarks
Nil					

RJSB AD 2.11 METEOROLOGICAL INFORMATION PROVIDED

1	Associated MET Office	HACHINOHE
2	Hours of service MET Office outside hours	H24
3	Office responsible for TAF preparation Periods of validity	Nil
4	Trend forecast Interval of issuance	Nil
5	Briefing/ consultation provided	Nil
6	Flight documentation Language(s) used	Ja,En
7	Charts and other information available for briefing or consultation	S,U
8	Supplementary equipment available for providing information	Nil
9	ATS units provided with information	Nil
10	Additional information(limitation of service, etc.)	Nil

RJSB AD 2.12 RUNWAY PHYSICAL CHARACTERISTICS

Designations RWY NR	TRUE BRG	Dimensions of RWY(M)	Strength(PCN) and surface of RWY	THR coordinates THR geoid undulation	THR elevation and highest elevation of TDZ of precision APP RWY
1	2	3	4	5	6
07	063.57°	2250x45	SW36500kg(80500lbs) DW56000kg(123500lbs) DTW117000kg(258000lbs) Concrete	403251.01N 1412718.94E	THR ELEV : 152ft
25	243.57°	2250x45	SW36500kg(80500lbs) DW56000kg(123500lbs) DTW117000kg(258000lbs) Concrete	403323.51N 1412844.64E	THR ELEV : 96.9ft TDZ ELEV : 118.8ft
Slope of RWY		Strip Dimensions(M)	Remarks		
7		10	12		
See below figure		2370x300 2370x300	Nil		

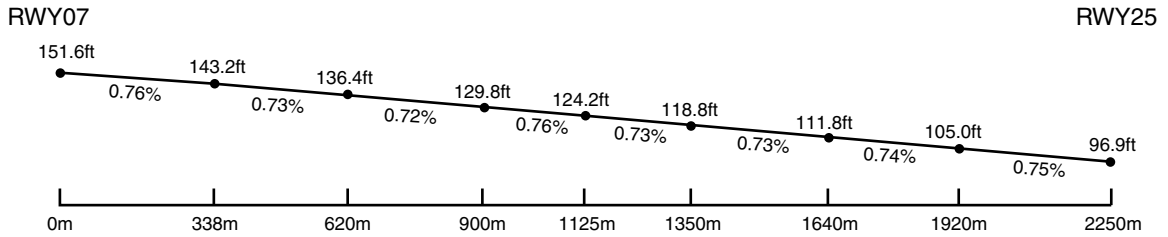

RJSH AD 2.13 DECLARED DISTANCES

RWY Designator	TORA (m)	TODA (m)	ASDA (m)	LDA (m)	Remarks
1	2	3	4	5	6

RJSH AD 2.14 APPROACH AND RUNWAY LIGHTING

RWY Designator	APCH LGT type LEN INTST	RTHL Color WBAR	PAPI (VASIS) Angle DIST FM THR MEHT	RTZL LEN	RCLL LEN Spacing Color INTST	REDL LEN Spacing Color INTST	RENL Color WBAR	STWL LEN Color
1	2	3	4	5	6	7	8	9
07			PAPI 3.0°/Left 334m 45ft					
25	AVBL		PAPI 2.5°/Left 395m 59ft					
Remarks								
10								
RWY THR ID LGT for RWY07 THR (Color:White)								

RJSH AD 2.15 OTHER LIGHTING, SECONDARY POWER SUPPLY

1	ABN/IBN location, characteristics and hours of operation	ABN: 403249N/1412816E, White/Green EV10sec, HO
2	LDI location and LGT Anemometer location and LGT	LDI:LGTD
3	TWY edge and centerline lighting	TWY edge LGT:AVBL
4	Secondary power supply/ switch-over time	Nil
5	Remarks	WDI LGT, OBST LGT

RJSH AD 2.16 HELICOPTER LANDING AREA

To be issued later

RJSH AD 2.17 ATS AIRSPACE

Designation and lateral limits		Vertical limits (ft)	Airspace classification	ATS unit call sign Language	Remarks
1		2	3	4	6
HACHINOHE CTR	Area within a radius of 5 nm of HACHINOHE ARP(40°33'N 141°28'E)	6000 or below	D	HACHINOHE TOWER En	

RJSH AD 2.18 ATS COMMUNICATION FACILITIES

Service designation	Call sign	Frequency	Hours of operation	Remarks
1	2	3	4	5
TWR	Hachinohe Tower	228.2MHz 126.2MHz(4) 325.4MHz 138.3MHz 236.8MHz(2)(3) 123.1MHz(1) 121.5MHz(E) 243.0MHz(E) 141.2MHz	H24	APP provided by Misawa APP. (1)For rescue only. (2)Required specification on flight plan. (3)AVBL on request (4)Secondary
GND	Hachinohe Ground	325.4MHz	H24	
GCA-ASR -PAR	Hachinohe GCA	335.6MHz 270.8MHz 134.1MHz 125.3MHz 335.8MHz 289.4MHz 258.6MHz 139.55MHz 123.1MHz(1) 258.2MHz 243.0MHz(E) 121.5MHz(E)	2300 - 0800 EXC FRI0801 - SUN2259 and HOL Other time 1HR PN	ASR RWY 07/25 PAR RWY 25 Glide path 2.5° Maintenance period: 2300 - 0800 1st SAT in VMC
ATIS	Hachinohe Airport	245.8MHz	2200 - 1300 EXC FRI1301 - SUN2159 and HOL Other time 1HR PN	

RJSH AD 2.19 RADIO NAVIGATION AND LANDING AIDS

Type of aid	ID	Frequency	Hours of operation	Position of transmitting antenna coordinates	Elevation of DME transmitting antenna	Remarks
1	2	3	4	5	6	7
TACAN	HVT	984MHz (CH-23X)	H24	403321N 1412812E	45.1m (147.9ft)	TACAN Unusable: R040-050 beyond 35NM BLW 2000ft. R060-070 beyond 36NM BLW 2000ft. R140-150 beyond 35NM BLW 5000ft. R150-170 beyond 32NM BLW 7000ft. R320-330 beyond 35NM BLW 5000ft. R330-340 beyond 25NM BLW 5000ft. R340-350 beyond 30NM BLW 4000ft. R350-360 beyond 35NM BLW 4000ft.
ILS-LOC 25	IHE	111.3MHz	H24	403247N 1412709E		LOC : 274m(899ft) away FM RWY 07 THR,BRG(MAG)251°
ILS-GP 25		332.3MHz	H24	403322N 1412830E		GP:330m(1083ft) inside FM RWY 25 THR,125m(410ft) N of RCL. HGT of ILS Ref datum 16.8m(55ft) Angle 2.5°
ILS-DME 25	IHE	1011MHz (CH-50X)	H24	403322N 1412829E	35.9m (117.9ft)	DME:333m(1093ft) inside FM RWY 25 THR, 131m(430ft) N of RCL.

ILS for RWY25

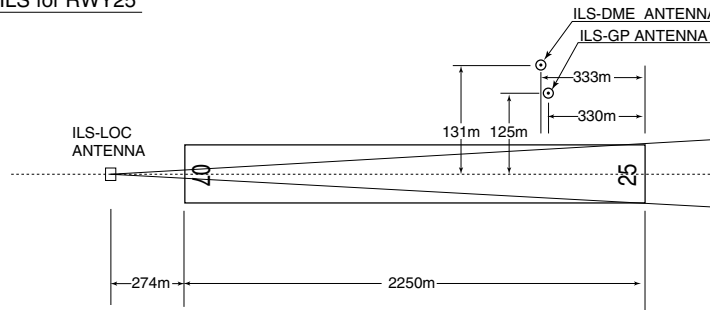

- REMARKS : 1. LOC beam BRG(MAG) 251°
 2. HGT of ILS REF datum 16.8m (55ft)
 3. GP Angle 2.5°
 4. ELEV of ILS-DME 35.9m(117.9ft)

RJSH AD 2.20 LOCAL TRAFFIC REGULATIONS

1. Airport regulations

Nil

2. Taxiing to and from stands

Nil

3. Parking area for small aircraft(General aviation)

Nil

4. Parking area for helicopters

Nil

5. Apron - taxiing during winter conditions

Nil

6. Taxiing - limitations

Nil

7. School and training flights - technical test flights - use of runways

Nil

8. Helicopter traffic - limitation

Nil

9. Removal of disabled aircraft from runways

Nil

RJSH AD 2.21 NOISE ABATEMENT PROCEDURES

Nil

RJSH AD 2.22 FLIGHT PROCEDURES

1.TAKE OFF MINIMA

	RWY	ACFT CAT	REDL & RCLL		REDL or RCLL or RCL Marking		NIL (DAYTIME ONLY)	
			RVR	VIS	RVR	VIS	RVR	VIS
Multi-Engine ACFT with TKOF ALTN AP FILED	07	A,B,C,D	-	-	-	400m	-	500m
	25		-	-	400m	400m	-	500m
OTHER	07	A,B,C,D	AVBL LDG MINIMA					
	25							

2.WX MINIMA CONCERNING PAR/ASR APCH PROCEDURE

ASR RWY 25

MINIMA		THR elev. 97	AD elev. 152
CAT			CIRCLING
	MDA(H)	RVR/CMV	MDA(H) VIS
A	580 (483)	1400	640 (488) 1600
B		1500	
C		1600	720 (568) 2400
D		1800	

ASR RWY 07

MINIMA		THR elev. 152	AD elev. 152
CAT			CIRCLING
	MDA(H)	CMV	MDA(H) VIS
A	660 (508)	1500	660 (508) 1600
B			
C		2000	720 (568) 2400
D			

PAR RWY 25

MINIMA		THR elev. 97	AD elev. 152
CAT			CIRCLING
	DA(H)	RVR/CMV	MDA(H) VIS
A	320 (223)	750	640 (488) 1600
B			
C			720 (568) 2400
D			

3. Lost communication procedures for arrival aircraft under radar navigational guidance

If radio communications with Hachinohe GCA are lost for 1 minute(PAR,ASR RWY 25)/30 seconds(ASR RWY 07)in the pattern or 5 seconds (PAR)/15 seconds (ASR) on final approach, squawk Mode A/3 Code 7600 and;

- (I)
 - 1. Contact Misawa Radar.
 - 2. If unable, proceed in accordance with visual flight rules.
 - 3. If unable, proceed to ENBRY at last assigned altitude or 3,000 feet whichever is higher, and execute instrument approach.
- (II) Procedures other than above will be issued when situation required.

RJSH AD 2.23 ADDITIONAL INFORMATION

Nil

RJSH AD 2.24 CHARTS RELATED TO AN AERODROME

Standard Departure Chart - Instrument
Instrument Approach Chart (ILS Z RWY25)
Instrument Approach Chart (ILS Y RWY25)
Instrument Approach Chart (LOC Z RWY25)
Instrument Approach Chart (LOC Y RWY25)
Instrument Approach Chart (TACAN RWY25)
Other Chart (LDG CHART)

STANDARD DEPARTURE CHART -INSTRUMENT

RJSH / HACHINOHE

SID

HACHINOHE FOUR DEPARTURE

RWY07 : Climb RWY HDG to 800FT, turn right, ...

RWY25 : Climb RWY HDG to 1000FT, turn left, ...

... direct to HVT TACAN.

Cross HVT TACAN at or above 3000FT.

NOTE RWY25 : 4.0% climb gradient required up to 1000FT.

OBST ALT 317FT located at 0.9NM 266° FM end of RWY25.

CHANGE : PROC(HACHINOHE FOUR DEPARTURE) renamed. PROC(HACHINOHE REVERSAL TWO DEPARTURE) abolished. PROC Course.

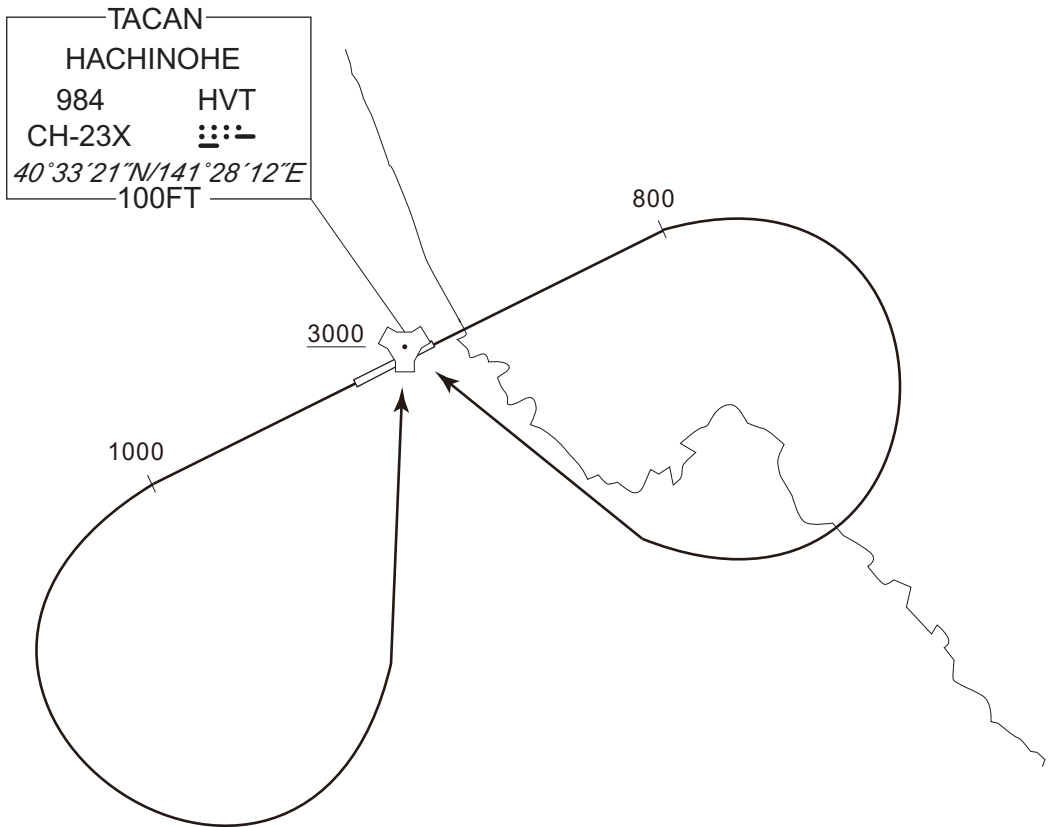

INTENTIONALLY LEFT BLANK

INSTRUMENT APPROACH CHART

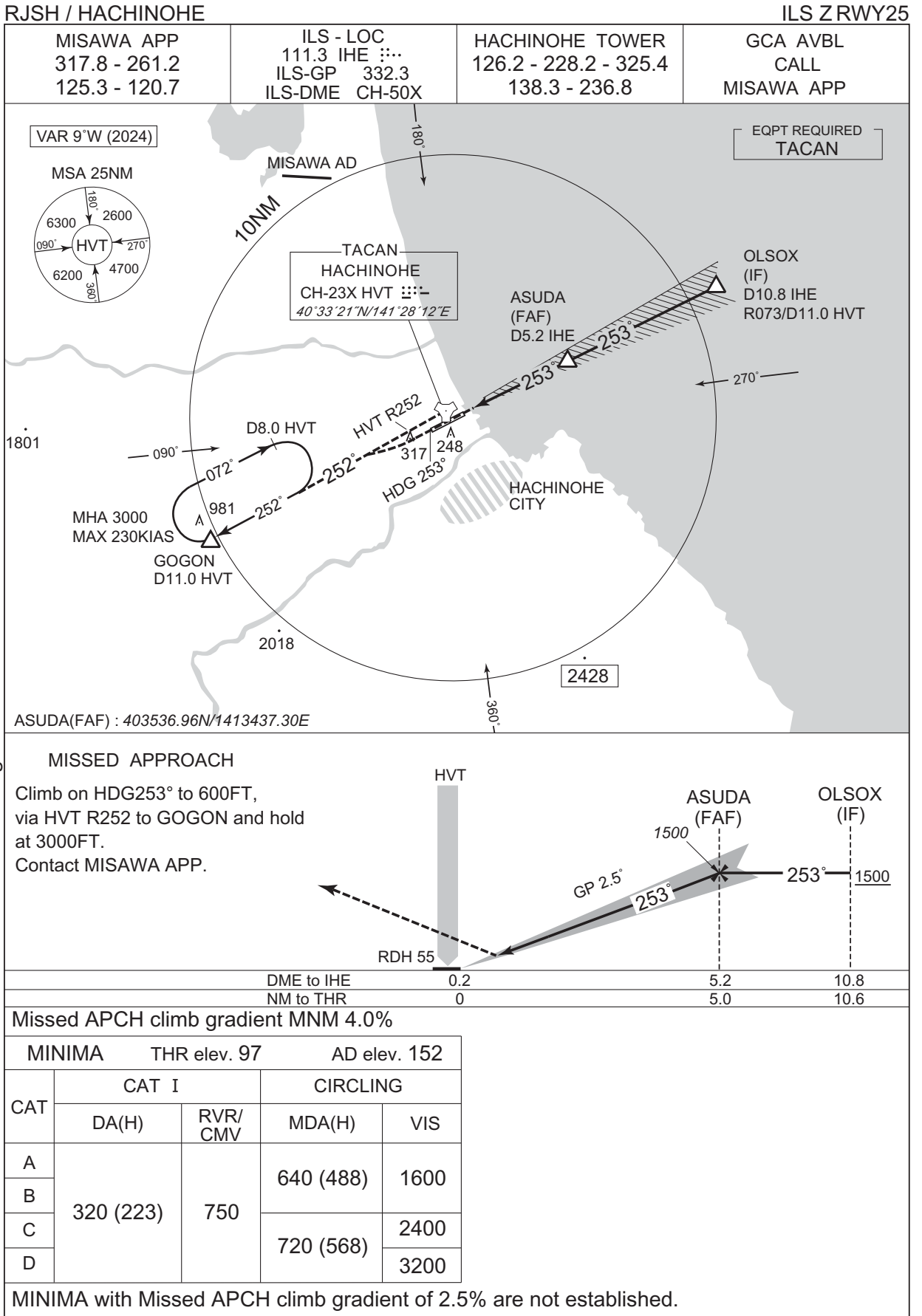

CHANGE : PROC renamed. VAR. MSA. PROC Course. Missed APCH Course. OBST. ASUDA, OLSOX, GOGON established. DME to IHE. NM to THR. Missed APCH climb gradient MNM added. MINIMA.

INSTRUMENT APPROACH CHART

RJSH / HACHINOHE

ILS Y RWY25

MISAWA APP 317.8 - 261.2 125.3 - 120.7	ILS-LOC 111.3 IHE ILS-GP 332.3 ILS-DME CH-50X	HACHINOHE TOWER 126.2 - 228.2 - 325.4 138.3 - 236.8	GCA AVBL CALL MISAWA APP
--	--	---	--------------------------------

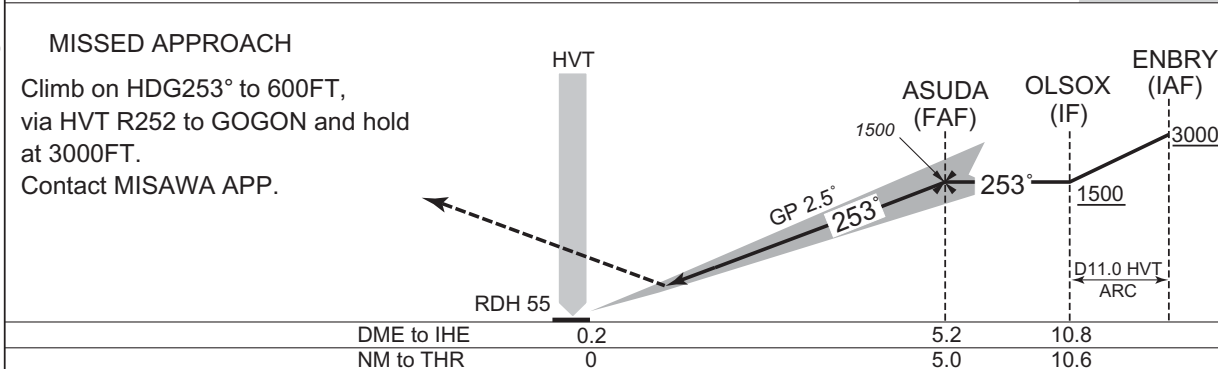
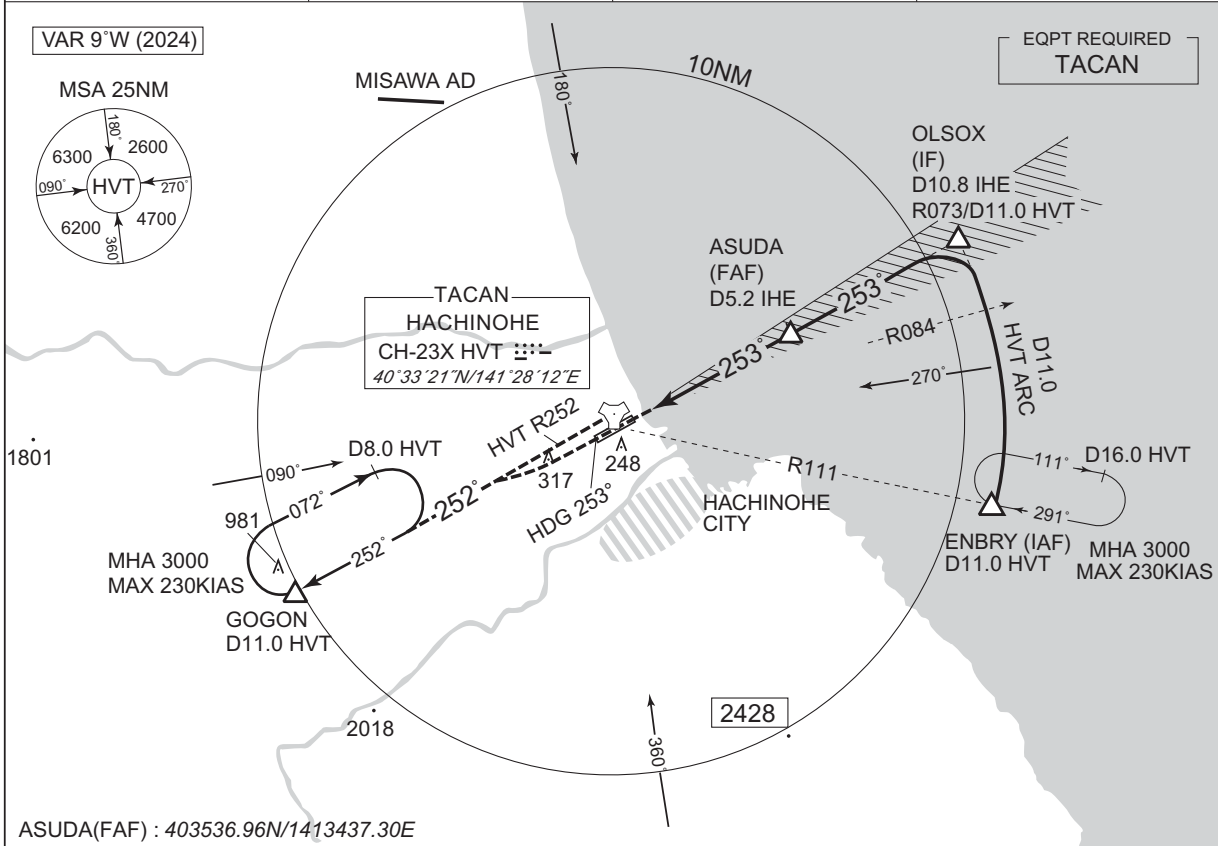

Missed APCH climb gradient MNM 4.0%

CAT	CAT I		CIRCLING	
	DA(H)	RVR/CMV	MDA(H)	VIS
A	320 (223)	750	640 (488)	1600
B				2400
C			720 (568)	3200
D				

MINIMA with Missed APCH climb gradient of 2.5% are not established.

CHANGE : PROC renamed. VAR. MSA. PROC Course. Missed APCH Course. OBST. ASUDA, OLSOX, GOGON established. DME to IHE. NM to THR. Missed APCH climb gradient MNM added. MINIMA.

INSTRUMENT APPROACH CHART

CHANGE : PROC renamed. VAR. MSA: PROC Course. Missed APCH Course. OBST. OCA(H). ASUDA, OLSOX, GOGON established. NM to IHE, ALT(3.0° APCH Path) added. DME to IHE. NM to THR. Missed APCH climb gradient MNM added. MINIMA.

RJSH / HACHINOHE LOC Z RWY25

MISAWA APP 317.8 - 261.2 125.3 - 120.7	ILS - LOC 111.3 IHE ⋯ ILS-GP 332.3 ILS-DME CH-50X	HACHINOHE TOWER 126.2 - 228.2 - 325.4 138.3 - 236.8	GCA AVBL CALL MISAWA APP
--	---	---	--------------------------------

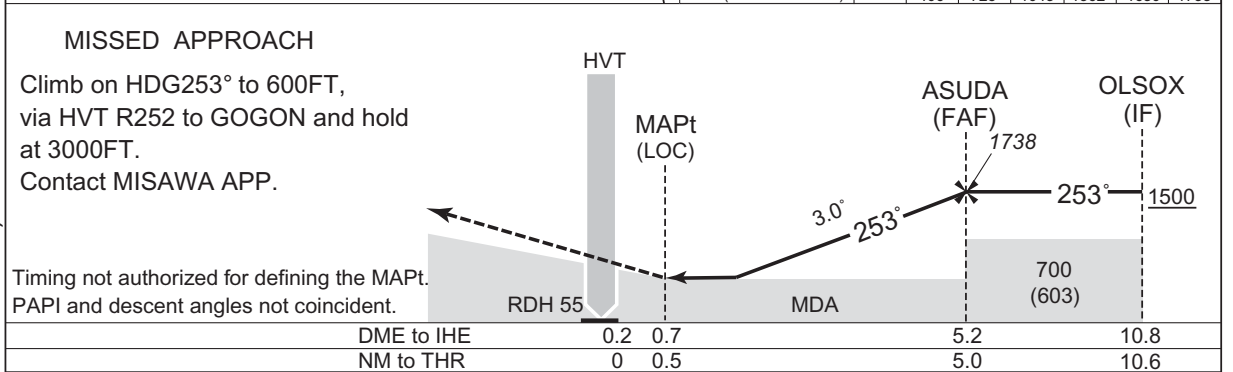
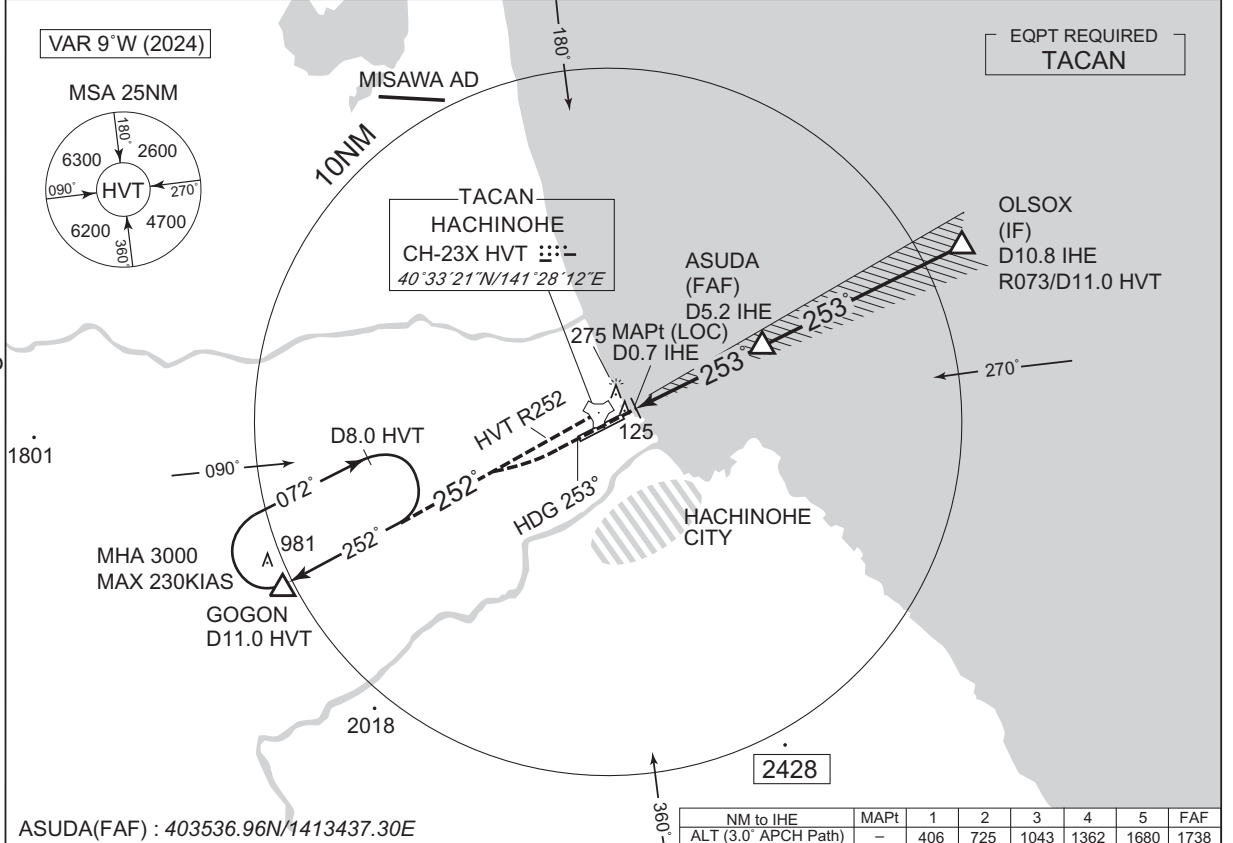

Missed APCH climb gradient MNM 4.0%

MINIMA	THR elev. 97	AD elev. 152		
CAT	LOC		CIRCLING	
	MDA(H)	RVR/CMV	MDA(H)	VIS
A	380 (283)	1000	640 (488)	1600
B		1100		
C		1200	720 (568)	2400
D		1400		3200

MINIMA with Missed APCH climb gradient of 2.5% are not established.

INSTRUMENT APPROACH CHART

RJSH / HACHINOHE LOC Y RWY25

MISAWA APP 317.8 - 261.2 125.3 - 120.7	ILS-LOC 111.3 IHE \cdots ILS-GP 332.3 ILS-DME CH-50X	HACHINOHE TOWER 126.2 - 228.2 - 325.4 138.3 - 236.8	GCA AVBL CALL MISAWA APP
--	---	---	--------------------------------

CHANGE : PROC renamed. VAR. MSA. PROC Course. Missed APCH PROC. OBST. OCA(H). ASUDA. OLSOX. GOGON established. NM to IHE, ALT(3.0° APCH Path) added. DME to IHE. NM to THR. Missed APCH climb gradient MNM added. MINIMA.

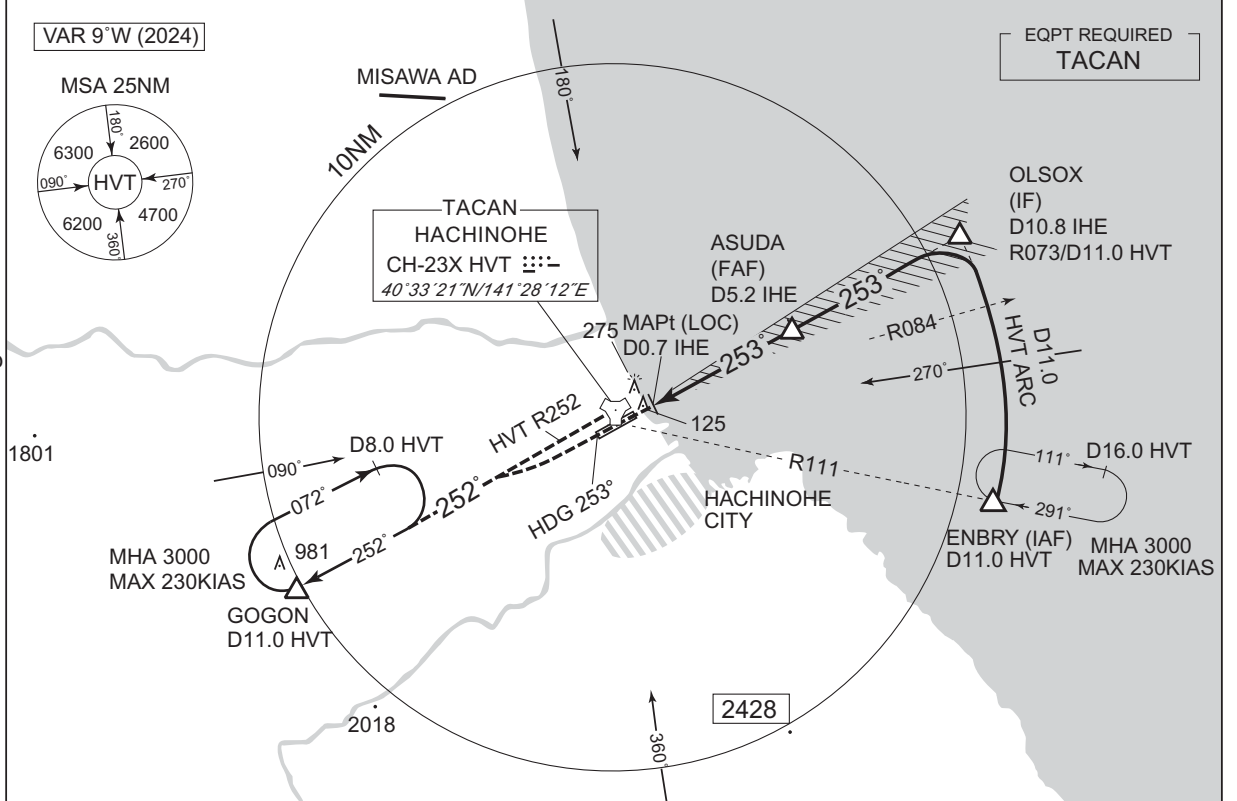

NM to IHE	MAPt	1	2	3	4	5	FAF
ALT (3.0° APCH Path)	-	406	725	1043	1362	1680	1738

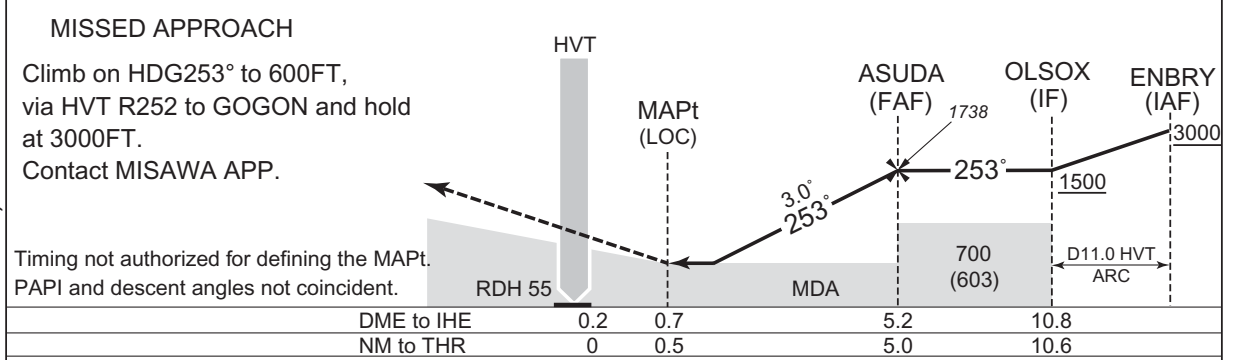

Missed APCH climb gradient MNM 4.0%

MINIMA	THR elev. 97	AD elev. 152		
CAT	LOC		CIRCLING	
	MDA(H)	RVR/CMV	MDA(H)	VIS
A	380 (283)	1000	640 (488)	1600
B		1100		
C		1200	720 (568)	2400
D		1400		

MINIMA with Missed APCH climb gradient of 2.5% are not established.

INSTRUMENT APPROACH CHART

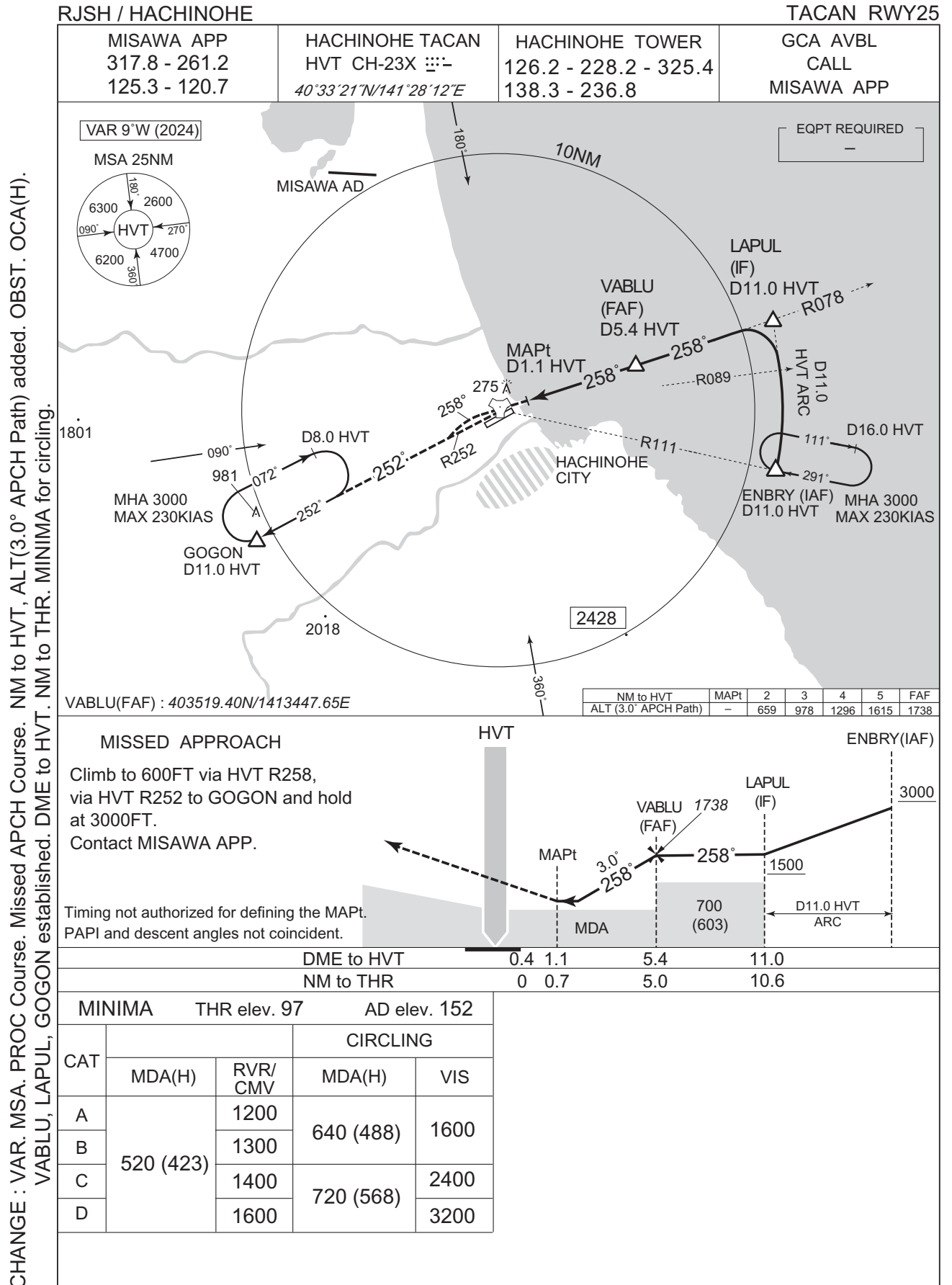

INTENTIONALLY LEFT BLANK

RJSH / HACHINOHE

LDG CHART

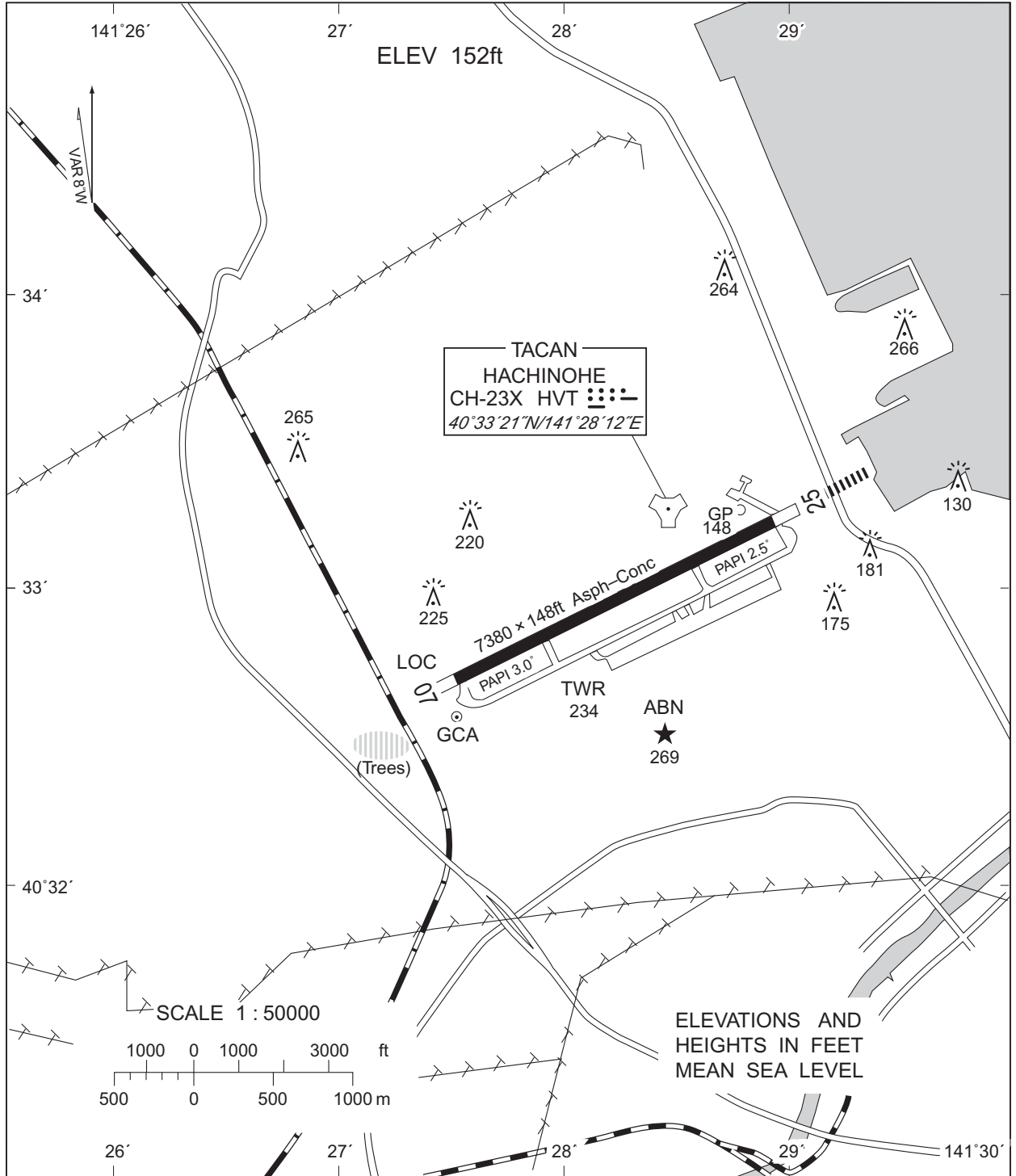

CHANGE : NDB(JC) abolished.

AERODROME LIGHTING

Aerodrome beacon : Alternating flash
white / green

Runway lighting : white

Threshold lighting : green

Others lighting : Lighted wind direction
indicator, Obstruction
light, Landing direction
indicator, Take off
aiming light.

APCH LGT : RWY 25—423m
TWY edge LGT
RWYTIL (for RWY 07 only)
PAPI (RWY 07/25)

INTENTIONALLY LEFT BLANK