

**AD 2 AERODROMES**

**RJSN AD 2.1 AERODROME LOCATION INDICATOR AND NAME**

**RJSN - NIIGATA**

**RJSN AD 2.2 AERODROME GEOGRAPHICAL AND ADMINISTRATIVE DATA**

1	ARP coordinates and site at AD	375721N 1390642E 270° / 1.1km FM RWY 28 THR
2	Direction and distance from (city)	6.7km NE of Niigata Railway Station
3	Elevation/ Reference temperature	4.6ft / 31°C (2004-2008)
4	Geoid undulation at AD ELEV PSN	Nil
5	MAG VAR/ Annual change	8°W (2008) / 0.3' W
6	AD Administration, address, telephone, telefax, telex, AFS, e-mail and/or Web-site addresses	Niigata Airport Office (Civil Aviation Bureau) 2350-4, Matsuhama-cho, Higashi-ku, Niigata-shi, Niigata Pref, Japan. AFS : RJSNYFYX Tel : 025(273)4567, 025(271)9711 (OPS)
7	Types of traffic permitted(IFR/ VFR)	IFR/VFR
8	Remarks	Nil

**RJSN AD 2.3 OPERATIONAL HOURS**

1	AD Administration	2230 - 1230
2	Customs and immigration	2330-0815
3	Health and sanitation	Quarantine(human): 2330-0815 Quarantine(animal): 2330-0800 Quarantine(plant): INTL SKED FLT hours only
4	AIS Briefing Office	2230 - 1230
5	ATS Reporting Office(ARO)	Nil
6	MET Briefing Office	H24 (TOKYO)
7	ATS	2230 - 1230
8	Fuelling	2230 - 1230
9	Handling	2230 - 1230
10	Security	2230 - 1230
11	De-icing	Nil
12	Remarks	Nil

**RJSN AD 2.4 HANDLING SERVICES AND FACILITIES**

1	Cargo-handling facilities	All the modern institutions that deal with the weight thing to Airbus 330
2	Fuel/ oil types	Fuel Grades : JET A-1, AVGAS 100LL Oil grades : 20W50, 15W50, W100
3	Fuelling facilities/ capacity	Fuel truck / Not limited
4	De-icing facilities	Nil
5	Hangar space for visiting aircraft	Nil
6	Repair facilities for visiting aircraft	Nil
7	Remarks	The prior permission of Oil company is required to foreign aircraft for refueling. (Except schedule Flight)

**RJSN AD 2.5 PASSENGER FACILITIES**

1	Hotels	Hotels in Niigata city
2	Restaurants	Available (2200 - 1000)
3	Transportation	Busses and Taxis
4	Medical facilities	Hospitals in Niigata city (4km from Airport)
5	Bank and Post Office	Bank :At Airport Post Office :1km S of Airport
6	Tourist Office	Nil
7	Remarks	Nil

**RJSN AD 2.6 RESCUE AND FIRE FIGHTING SERVICES**

1	AD category for fire fighting	CAT 9
2	Rescue equipment	Chemical fire fighting truck x 3 Water-supply truck x 1, Lighting power supply truck x 1, Emergency medical equipments conveyance truck x 1
3	Capability for removal of disabled aircraft	Nil
4	Remarks	Nil

**RJSN AD 2.7 SEASONAL AVAILABILITY-CLEARING**

1	Types of clearing equipment	Snow Removal Equipments : Rotary x 2, Snow plows x 6, Snow sweeper x 4, Road sweeper X 1
2	Clearance priorities	1.RWY 10/28 , TWY C1-C6,B1,B5 SPOT NR4-8 2.TWY P3,B2-B4 SPOT NR1-3,NR9,NR10 S-Apron, S-TWY , RWY 04/22(FM S-TWY TO C-TWY)
3	Remarks	Seasonal availability : All seasons In the case of deposits(snow, slush and ice) on the movement areas, report will be issued as NOTAM(domestic distribution only) at least once a day.

**RJSN AD 2.8 APRONS, TAXIWAYS AND CHECK LOCATIONS DATA**

1	Apron surface and strength	Surface : Asphalt Concrete and Concrete, semi-flexible pavement Strength : SPOT 1-10: PCN 74/R/C/X/T S Apron : AUW 11t
2	Taxiway width, surface and strength	Surface : Asphalt concrete and concrete Strength : A1, A3 and P4 : PCN 14/F/C/Y/T B1- B5,C1, C2 , C4 - C6 and P3 : PCN 91/F/C/X/T C3 : PCN 74/R/C/X/T S : AUW 11t Width : B1 : 29m B5 : 28.5m B2 - B4 and P3 : 30m A1, A3, C1-C6 and P4 : 23m S : 18m
3	ACL and elevation	Location : Not available Elevation : Not available
4	VOR checkpoints	Not available
5	INS checkpoints	Spot NR 1: 375711.53N 1390636.75E 2: 375711.93N 1390638.19E 3: 375710.93N 1390640.71E 4: 375710.86N 1390642.55E 5: 375710.82N 1390644.71E 6: 375710.78N 1390647.37E 7: 375710.68N 1390650.23E 8: 375710.51N 1390652.89E 9: 375710.48N 1390655.65E 10: 375710.27N 1390658.41E
6	Remarks	Nil

## RJSN AD 2.9 SURFACE MOVEMENT GUIDANCE AND CONTROL SYSTEM AND MARKINGS

1	Use of aircraft stand ID signs, TWY guide lines and Visual docking/ parking guidance system of aircraft stands	Aircraft stand identification signs:Spot NR 5-8 Aircraft stand taxi lane:C1, C2, B1-B5, P3 Visual docking guidance system: Nil
2	RWY and TWY markings and LGT	<p>RWY:10/28 (Marking) RWY designation, RWY CL, RWY THR, Aiming point, TDZ, RWY side stripe (LGT) RCLL, REDL, RTHL, RENL, RTZL(RWY28), WBAR(RWY28)</p> <p>RWY:04/22 (Marking) RWY designation, RWY CL, RWY middle point, Aiming point(RWY04), TDZ (LGT) REDL, RTHL, RENL</p> <p>TWY: B1-B5 and P3 (Marking) TWY CL, RWY HLDG PSN, TWY side stripe, Mandatory instruction (LGT) TWY edge LGT, TWY CL LGT, RWY guard LGT, Taxiing guidance sign</p> <p>TWY: C1, C2 (Marking) TWY CL, RWY HLDG PSN, TWY side stripe, Mandatory instruction (LGT) TWY edge LGT, TWY CL LGT, RWY guard LGT, Taxiing guidance sign</p> <p>TWY: C3-C6 (Marking)TWY CL, RWY HLDG PSN, TWY side stripe, Mandatory instruction (LGT) TWY edge LGT, TWY CL LGT</p> <p>TWY: S (Marking) TWY CL, RWY HLDG PSN, TWY side stripe, Mandatory instruction (LGT) TWY edge LGT</p> <p>TWY:A1, A3, P4 (Marking) TWY CL, RWY HLDG PSN, Mandatory instruction (LGT) Nil</p>
3	Stop bars	Nil
4	Remarks	(Marking) Overrun area (LGT) Apron flood LGT

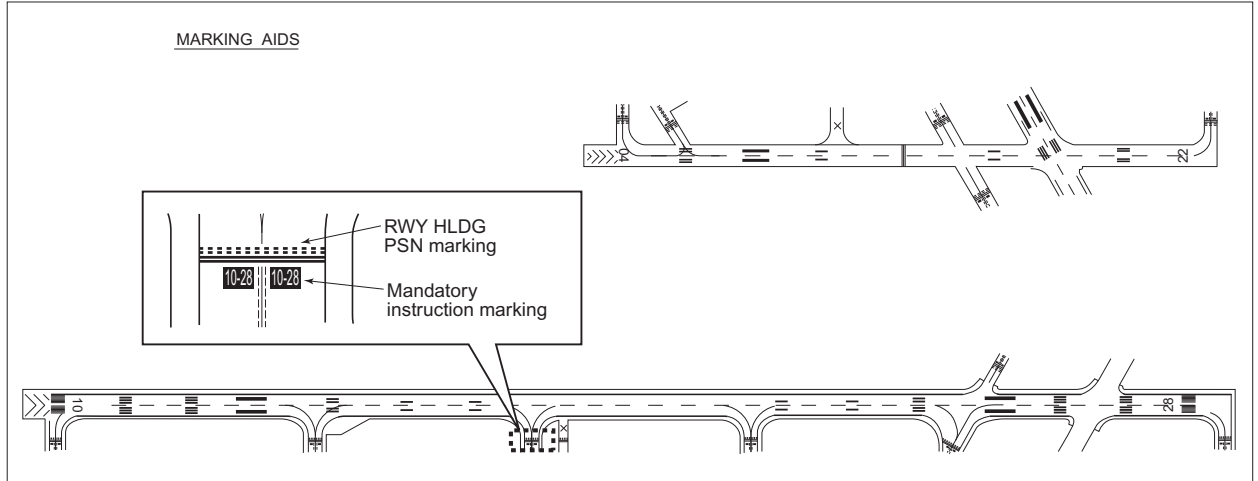

**RJSN AD 2.10 AERODROME OBSTACLES**

In approach / TKOF Areas

RWY/Area affected	Obstacle type	Coordinates	Elevation	Markings/ LGT	Remarks
See Obstacle Chart					

In circling area and at AD

Obstacle type	Coordinates	Elevation	Markings/ LGT	Remarks
See Obstacle Chart				

## RJSN AD 2.11 METEOROLOGICAL INFORMATION PROVIDED

1	Associated MET Office	TOKYO
2	Hours of service MET Office outside hours	H24 (TOKYO)
3	Office responsible for TAF preparation Periods of validity	TOKYO 30 Hours
4	Trend forecast Interval of issuance	Nil
5	Briefing/ consultation provided	Briefing is available upon inquiry at TOKYO
6	Flight documentation Language(s) used	C En
7	Charts and other information available for briefing or consultation	S <sub>6</sub> , U <sub>85</sub> , U <sub>7</sub> , U <sub>5</sub> , U <sub>3</sub> , U <sub>25</sub> , U <sub>2</sub> /T <sub>1</sub> , P <sub>s</sub> , P <sub>5</sub> , P <sub>3</sub> , P <sub>25</sub> , P <sub>SWE</sub> , P <sub>SWF</sub> , P <sub>SWG</sub> , P <sub>SWI</sub> , P <sub>SWM</sub> , P <sub>SW</sub> (domestic), E, C, W <sub>E</sub> , W <sub>F</sub> , W <sub>G</sub> , W <sub>I</sub> , W, N
8	Supplementary equipment available for providing information	Nil
9	ATS units provided with information	TWR, APP, ATIS
10	Additional information(limitation of service, etc.)	Nil

**RJSN AD 2.12 RUNWAY PHYSICAL CHARACTERISTICS**

Designations RWY NR	TRUE BRG	Dimensions of RWY(M)	Strength(PCN) and surface of RWY	THR coordinates THR geoid undulation	THR elevation and highest elevation of TDZ of precision APP RWY
1	2	3	4	5	6
04	031.91°	1314x45	PCN 14/F/C/Y/T Asphalt Concrete	375653.73N 1390652.82E	THR ELEV:22.7ft
22	211.91°	1314x45	PCN 14/F/C/Y/T Asphalt Concrete	375729.96N 1390721.31E	THR ELEV: 5.9ft
10	092.69°	2500x45	PCN 91/F/C/X/T Asphalt Concrete	375724.71N 1390541.78E	THR ELEV: 27.1ft
28	272.69°	2500x45	PCN 91/F/C/X/T Asphalt Concrete	375720.91N 1390724.09E	THR ELEV: 10.1ft TDZ ELEV: 8.0ft
Slope of RWY	Strip Dimensions(M)	RESA (Overrun) Dimensions (M)	Remarks		
7	10	11	14		
SEE ATTACHED CHART	1434x150 1434x150	84x(MNM:120 MAX:150)* 1x(MNM:120 MAX:121)*	Nil		
SEE ATTACHED CHART	2620x300 2620x300	30x(MNM:195 MAX:277)* 141x(MNM:116 MAX:299)*	RWY grooving: 2500mx45m		
*For detail, ask airport administrator					

**RWY 10**

**RWY 28**

**RWY 22**

**RWY 04**

## RJSN AD 2.13 DECLARED DISTANCES

RWY Designator	TORA (m)	TODA (m)	ASDA (m)	LDA (m)	Remarks
1	2	3	4	5	6
04	1314	1314	1314	1314	Nil
22	1314	1314	1314	1314	Nil
10	2500	2500	2500	2500	Nil
28	2500	2500	2500	2500	Nil

## RJSN AD 2.14 APPROACH AND RUNWAY LIGHTING

RWY Designator	APCH LGT type LEN INTST	RTHL Color WBAR	PAPI (VASIS) Angle DIST FM THR MEHT	RTZL LEN	RCLL LEN Spacing Color INTST	REDL LEN Spacing Color INTST	RENL Color WBAR	STWL LEN Color
1	2	3	4	5	6	7	8	9
04	-	Green Nil	-	-	-	1314m 60m White LIL	Red	Nil (*1)
22	-	Green Nil	PAPI 3.0°/Left 361m 61ft	-	-	1314m 60m White LIL	Red	Nil (*1)
10	SALS 420m LIH	Green Nil	PAPI 3.0°/Left 535m 75ft	-	2500m 30m Coded color (White/Red) LIH	2500m 60m Coded color (White/Yellow) LIH	Red	Nil (*1)
28	PALS (CAT I) 660m LIH	Green Green	PAPI 3.0°/Left 455m 65ft	900m	2500m 30m Coded color (White/Red) LIH	2500m 60m Coded color (White/Yellow) LIH	Red	Nil (*1)
Remarks								
10								
Overrun area edge LGT(LEN60m color:Red) (*1) RWY THR ID LGT for RWY04/22 THR(Color:White)								



**RJSN AD 2.15 OTHER LIGHTING, SECONDARY POWER SUPPLY**

1	ABN/IBN location, characteristics and hours of operation	ABN: 375701N/1390640E, White/Green EV4.3sec, HO
2	LDI location and LGT Anemometer location and LGT	LDI:Nil Anemometer: RWY28: 477.7m from RWY28 THR, LGTD RWY10: 318.5m from RWY10 THR, LGTD
3	TWY edge and center line lighting	TWY edge and center line lights installed, see AD2.9
4	Secondary power supply/ switch-over time	Within 1sec : REDL(RWY 10/28), RENL(RWY 10/28), RTHL(RWY 10/28), WBAR, RCLL and Overrun area edge LGT(RWY 10/28) Within 15sec: Other lights
5	Remarks	WDI LGT

**RJSN AD 2.16 HELICOPTER LANDING AREA**

Nil
-----

**RJSN AD 2.17 ATS AIRSPACE**

Designation and lateral limits		Vertical limits (ft)	Airspace classification	ATS unit call sign Language	Remarks
1		2	3	4	6
NIIGATA CTR	Area within a radius of 5NM of NIIGATA ARP (37 °57'N 139 °07'E).	3,000 or below	D	NIIGATA TWR En	Nil
NIIGATA ACA	SEE ATTACHED CHART		E	NIIGATA APP NIIGATA DEP NIIGATA Radar En	Nil

新潟進入管制区  
Niigata Approach Control Area

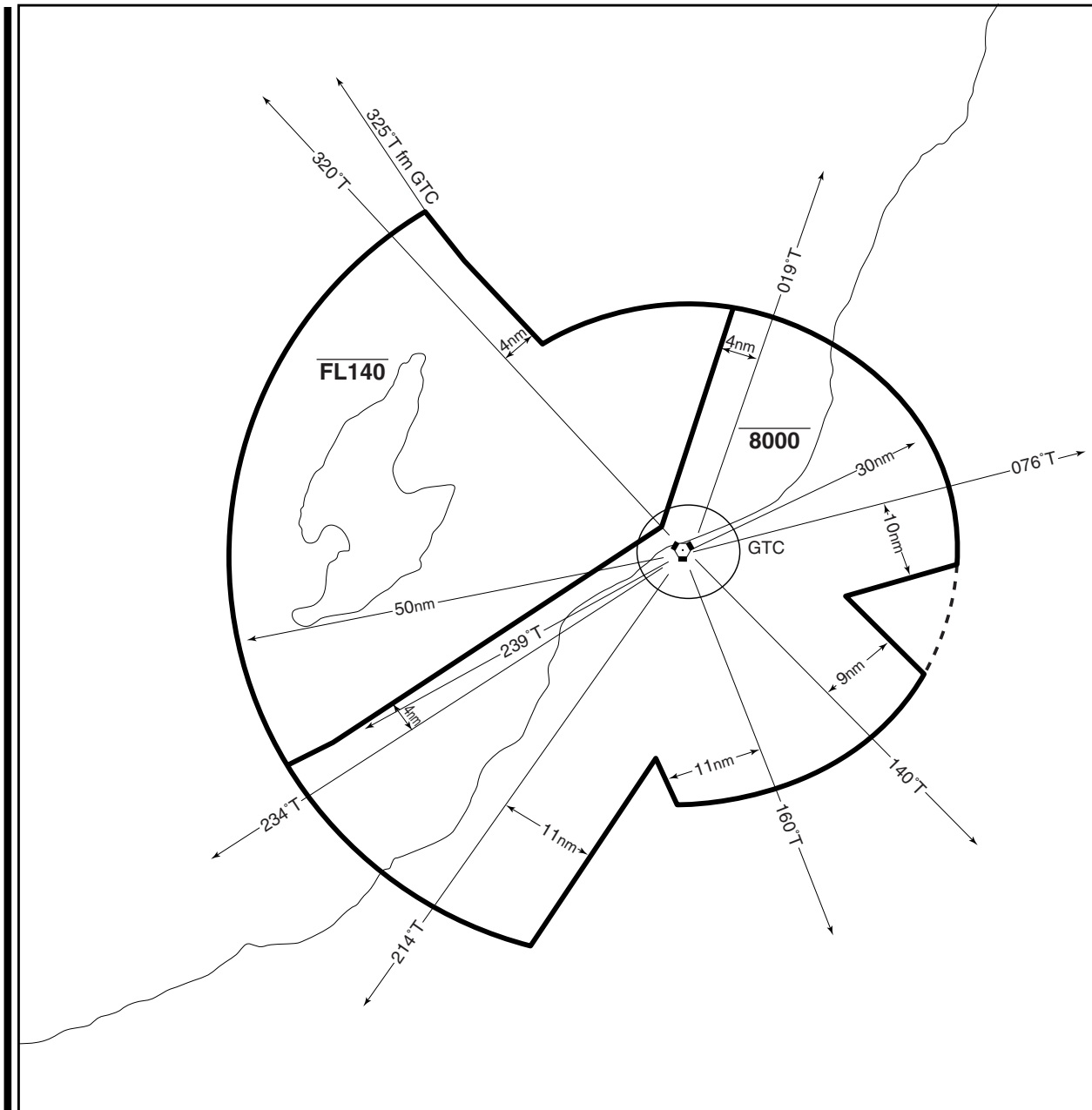

**RJSN AD 2.18 ATS COMMUNICATION FACILITIES**

Service designation	Call sign	Frequency	Hours of operation	Remarks
1	2	3	4	5
APP/ASR	Niigata Approach / Radar	121.4MHz 121.5MHz(E) 243.0MHz(E)	2230 - 1230	(1) Primary
DEP	Niigata Departure	119.05MHz 121.5MHz(E) 243.0MHz(E)	2230 - 1230	
TWR	Niigata Tower	118.0MHz(1) 126.2MHz 121.5MHz(E) 243.0MHz(E)	2230 - 1230	
ATIS	Niigata Airport	128.45MHz	2230 - 1230	

**RJSN AD 2.19 RADIO NAVIGATION AND LANDING AIDS**

Type of aid (VOR declination)	ID	Frequency	Hours of operation	Position of transmitting antenna coordinates	Elevation of DME transmitting antenna	Remarks
1	2	3	4	5	6	7
VOR (8°W/2022)	GTC	115.5MHz	H24	375729.86N 1390653.59E		
TACAN	GTC	1189MHz (CH-102X)	H24	375729.71N 1390656.04E	39ft	TACAN DME Unusable: 100°-110° beyond 35nm BLW 9,000ft.  TACAN AZM Unusable: 100°-120° beyond 35nm BLW 9,000ft. 320°-330° beyond 20nm BLW 3,000ft.
ILS-LOC 28	INC	109.3MHz	2230 - 1230	375724.99N 1390534.61E		LOC unusable: beyond 14nm FM antenna. LOC: 175m away FM RWY10 THR. BRG (MAG) 281.26°
ILS-GP 28	-	332.0MHz	2230 - 1230	375725.35N 1390710.02E		GP: 349m(1145ft) inside FM RWY28 THR, 120m(394ft) N of RCL. GP angle 3.0°. HGT of ILS Ref datum 16.5m(54ft).
ILS-DME 28	INC	991.0MHz (CH-30X)	2230 - 1230	375725.51N 1390709.72E	18ft	DME: 357m(1171ft) inside FM RWY28 THR, 125m(410ft) N of RCL.
MSAS		1575.42MHz	H24			Transmitting antennas are satellite based

RJSN / NIIGATA

ILS

ILS

NIIGATA AP

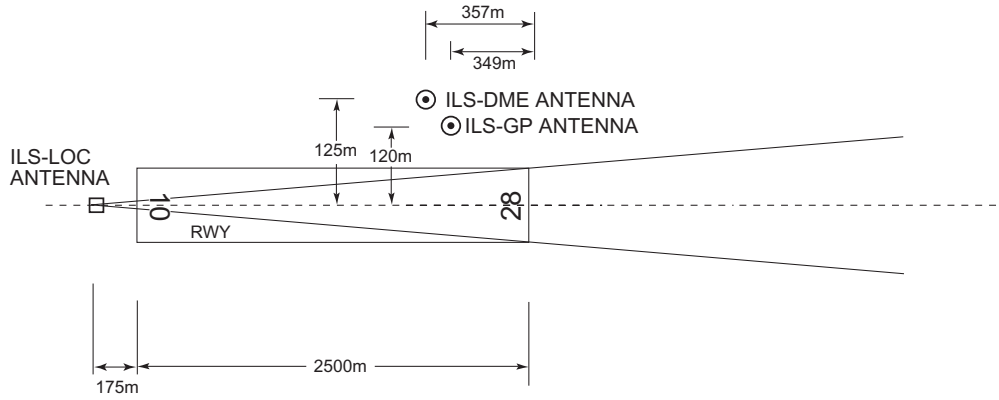

- REMARKS :
- |                         |              |
|-------------------------|--------------|
| 1. LOC beam BRG (MAG)   | 281.26°      |
| 2. HGT of ILS REF datum | 16.5m (54ft) |
| 3. GP Angle             | 3.0°         |
| 4. ELEV of ILS-DME      | 5.5m (18ft)  |

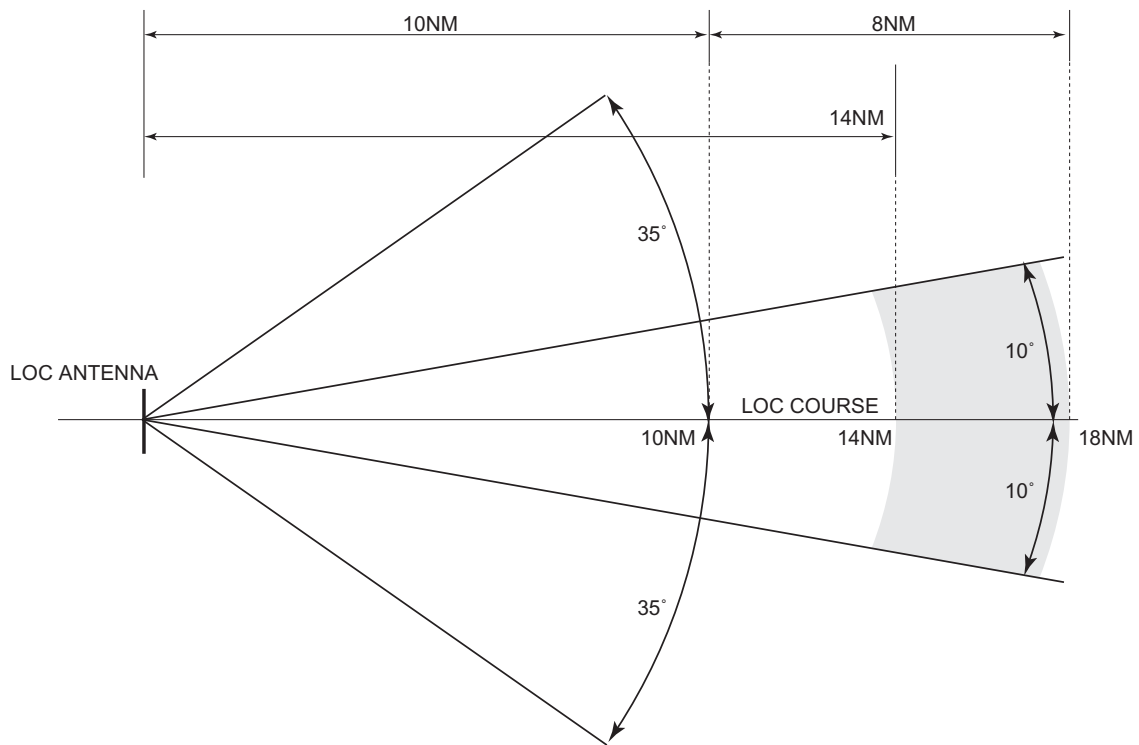

LOC Unusable beyond 14NM from antenna.

RJSN AD 2.20 LOCAL TRAFFIC REGULATIONS

1. Airport regulations

1.1 Transient ACFT operator is required to obtain the prior permission of the airport administrator.	
1.2 Special notice to Boeing 747-8 operators	
<p>1) 滑走路 滑走路 10/28 は幅 45m であり、両側に 10m の舗装ショルダーを設置している。 滑走路と平行誘導路の間隔は 184m である。</p> <p>滑走路 10/28 の停止位置標識は滑走路中心より 75m の位置にある。 滑走路 10/28 に着陸する B748 は、正確な進路を維持するため、デジタル・アビオニクスを備えかつ作動させること。</p>	<p>1) Runway The width of RWY10/28 is 45m and paved 10m shoulders are installed on each side of the runway. Separation distance between RWY10/28 center line and parallel taxiway center line is 184m. Runway-holding position markings for RWY10/28 are located at 75m from the runway center line. B748 which land on RWY10/28 should equip and activate Digital Avionics to maintain the precise path during approach.</p>
<p>2) 誘導路 誘導路 C1-C6 は 23m 幅であるので、走行に注意を要する。  誘導路 B2、B3、B4、P3 の走行においてオーバーステアリングが要求される。</p>	<p>2) Taxiways The width of taxiway C1-C6 is 23m. Pilots are requested to pay attention when taxiing at those taxiways. Pilots are requested to oversteer when turning into/out of taxiway B2,B3,B4 and P3.</p>
<p>3) 駐機場 駐機可能なスポットは、NR 9 である。</p>	<p>3) Parking stand Available Parking stand for B748 is NR9.</p>

2. Taxiing to and from stands

Nil
-----

3. Parking area for small aircraft(General aviation)

Nil
-----

4. Parking area for helicopters

Nil
-----

5. Apron - taxiing during winter conditions

Nil
-----

6. Taxiing - limitations

<b>Wing tip clearance at the TWY intersection (REF AD1.1.6.8)</b>				
Wing tip clearance at the TWY intersection between the aircraft holding at the stop marking on the TWY and the other aircraft taxiing behind it are as follows.				
When A306 holding at the stop marking on TWY B4				
wing span (WS) of acft taxiing on TWY C5-C6	WS ≤52.2m	52.2m <WS ≤69.2m	WS >69.2m	Legend *A : wing tip clearance ≥ 15m *B : 6.5m ≤ wing tip clearance < 15m *C : wing tip clearance < 6.5m
wing tip clearance	*A	*B	*C	

## 7. School and training flights - technical test flights - use of runways

Nil

## 8. Helicopter traffic - limitation

Nil

## 9. Removal of disabled aircraft from runways

Nil

**RJSN AD 2.21 NOISE ABATEMENT PROCEDURES****1. 騒音軽減運航方式**

すべてのジェット機に対して、空港周辺における航空機騒音軽減のため、運航の安全に支障のない範囲で、以下の方式が適用される。ただし、これらの方式によることができない航空機は実効的にこれらと同等と認められる代替方式を実施するものとする。

- 1) 離陸について（滑走路 10）  
急上昇方式
- 2) 着陸について（滑走路 28）  
デイレイド・フラップ進入方式 及び  
低フラップ角着陸方式
- 3) リバース・スラストについて  
なし

**2. 優先滑走路方式**

なし

**3. 優先飛行経路**

最大離陸重量7,000kg(15,500lbs)を超えるすべての固定翼機に対して、航行の安全確保及び飛行の目的に支障がない範囲において適用される。  
滑走路 10 から離陸する場合、新潟 VORTAC から 2 海里の地点を通過するまで直線飛行する。

**1. Noise Abatement Operating Procedures**

For all jet aircraft , In order to reduce aircraft noise in the vicinity of airport, the following procedures shall be applied unless compliance of the procedures adversely affects the safety of aircraft operations. In case that the aircraft is unable to take these procedures, pilots should execute alternative procedures which are considered to be practically equivalent.

- 1) For take-off from RWY 10  
Steepest Climb Procedure
- 2) For landing to RWY 28  
Delayed Flap Approach Procedure and  
Reduced Flap Setting Procedure
- 3) Reverse Thrust  
Nil

**2. Preferential Runways Procedures**

Nil

**3. Noise Preferential Routes**

For all fixed wing aircraft over 7,000kg(15,500lbs) maximum take-off weight, the following noise preferential routes are adopted, as long as flight safety in not jeopardized or purpose of flight is not hindered.  
Take-off from RWY10, pilots are requested to strictly follow extended runway centerline until passing 2NM from Niigata VORTAC.

**RJSN AD 2.22 FLIGHT PROCEDURES**

**1. TAKE OFF MINIMA**

	RWY	ACFT CAT	REDL & RCLL		REDL or RCLL or RCL Marking		NIL (DAYTIME ONLY)	
			CEIL-RVR	CEIL-VIS	CEIL-RVR	CEIL-VIS	CEIL-RVR	CEIL-VIS
Multi-Engine ACFT with TKOF ALTN AP FILED	10	A,B,C,D	-	0'400m	-	0'400m	-	0'500m
	28	A,B,C,D	0'400m	0'400m	0'400m	0'400m	-	0'500m
	04	A,B,C	-	-	-	0'400m	-	0'500m
	22	A,B,C	-	-	-	200'2400m	-	200'2400m
OTHER	10 28	A,B,C,D	AVBL LDG MINIMA					
	04 22	A,B,C						

**2. Lost communication procedures for arrival aircraft under radar navigational guidance**

If radio communications with Niigata Approach/Radar are lost for 30 seconds, squawk Mode A/3 Code 7600 and;

- (I) 1. Contact Niigata Tower.
- 2. If unable, proceed in accordance with visual flight rules,
- 3. If unable, proceed to Niigata VORTAC at last assigned altitude or 4,000 feet whichever is higher, and execute instrument approach.
- (II) Procedures other than above will be issued when situation required.

**3. Trajectorized Airport Traffic Data Processing System (TAPS)**

Aircraft flying in Niigata approach control area under its control will be instructed to reply with discrete code on Mode A/3 and Mode C. If an aircraft has no capability of replying with discrete code, the pilot shall report ATC if so instructed.

新潟アプローチの指示のもとに、当該進入管制区を飛行する航空機は、モード A/3 の二次レーダー個別コード及びモード C による応答を指示される。

二次レーダー個別コードを搭載していない航空機が当該コードによる応答を指示された場合は、管制官に対しその旨通報すること。

**4. Flying restrictions:**

No flight shall be permitted below minimum safe altitude over the petroleum complex area.

RJSN AD 2.23 ADDITIONAL INFORMATION

1. A red-roofed house approx 10M AGL (15M MSL)  
located at position 290M outward on 218 deg. mag. from RWY 04 THR.
2. RWY10 進入区域の船舶の通過  
航空機の運航に影響がある高さの船舶が RWY10 進入区域を通過する場合、以下の対応が取られる。
  - (1) NOTAM RJSN 又は ATC により船舶の情報提供が行われる。
  - (2) 以下の場合において、船舶が A 点～B 点を通過する間、待機が指示されることがある。船舶高は水面上の高さとする。
    - a) RWY10 着陸時  
船舶高が 46m (150ft) 超の場合、RNP AR 進入を行う到着機  
船舶高が 53m (174ft) 超の場合、全ての到着機
    - b) RWY28 出発時及び着陸時  
船舶高が 57m (188ft) 超の場合、IFR 出発機  
船舶高が 93m (306ft) 超の場合、IFR 到着機
2. Passage of vessel across RWY10 approach area  
While vessel with height that affects ACFT operations is passing across RWY10 approach area, the following action will be taken.
  - (1) The information of vessel will be provided by NOTAM RJSN or ATC.
  - (2) While vessel is crossing between point A and point B, holding instruction may be issued in the following situations. Vessel height shall be the height above the water surface.
    - a) ACFT for landing RWY10  
When vessel height is above 46m (150ft): arrival ACFT to conduct RNP AR APCH  
When vessel height is above 53m (174ft): all arrival ACFT
    - b) ACFT for take-off/landing RWY28  
When vessel height is above 57m(188ft): IFR departure ACFT  
When vessel height is above 93m(306ft): IFR arrival ACFT

船舶経路

VESSEL COURSE

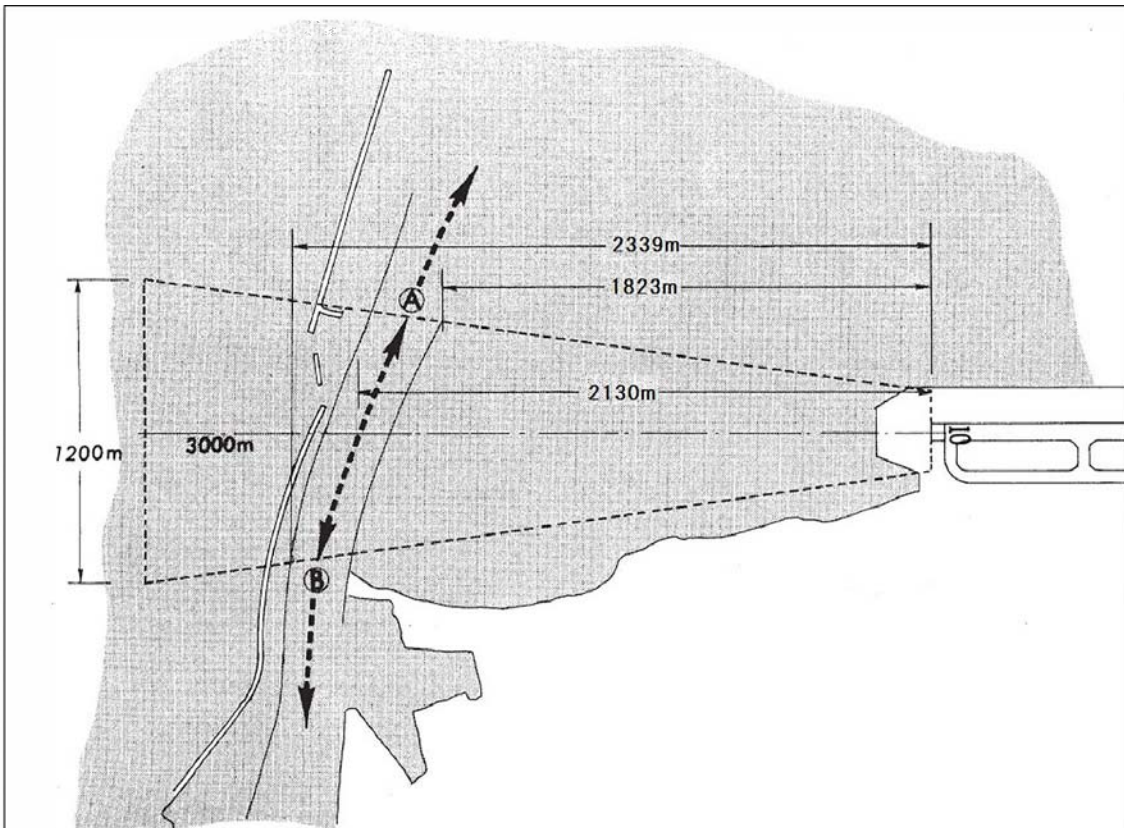



---

**RJSN AD 2.24 CHARTS RELATED TO AN AERODROME**

Aerodrome/Heliport Chart-1  
Aerodrome/Heliport Chart-2  
Aerodrome Obstacle Chart type A (RWY10/28)  
Aerodrome Obstacle Chart type B  
Standard Departure Chart - Instrument (OKESA)  
Standard Departure Chart - Instrument (NIIGATA)  
Standard Departure Chart - Instrument (SASAGA-RNAV)  
Standard Departure Chart - Instrument (MOKBA-RNAV)  
Standard Departure Chart - Instrument (SUKOB-RNAV)  
Standard Arrival Chart - Instrument (INAHO, GOSEN, MAGNA, TERAD-RNAV)  
Standard Arrival Chart - Instrument (KAETSU-RNAV)  
Instrument Approach Chart (ILS Z or LOC Z RWY28)  
Instrument Approach Chart (ILS Y or LOC Y RWY28)  
Instrument Approach Chart (VOR RWY28)  
Instrument Approach Chart (RNP Z RWY10)  
Instrument Approach Chart (RNP Y RWY10(AR))  
Instrument Approach Chart (VOR RWY10)  
Other Chart (Visual REP)  
Other Chart (TFC PATTERN)  
Other Chart (LDG CHART)  
Other Chart (MVA CHART)

**INTENTIONALLY LEFT BLANK**

AERODROME CHART

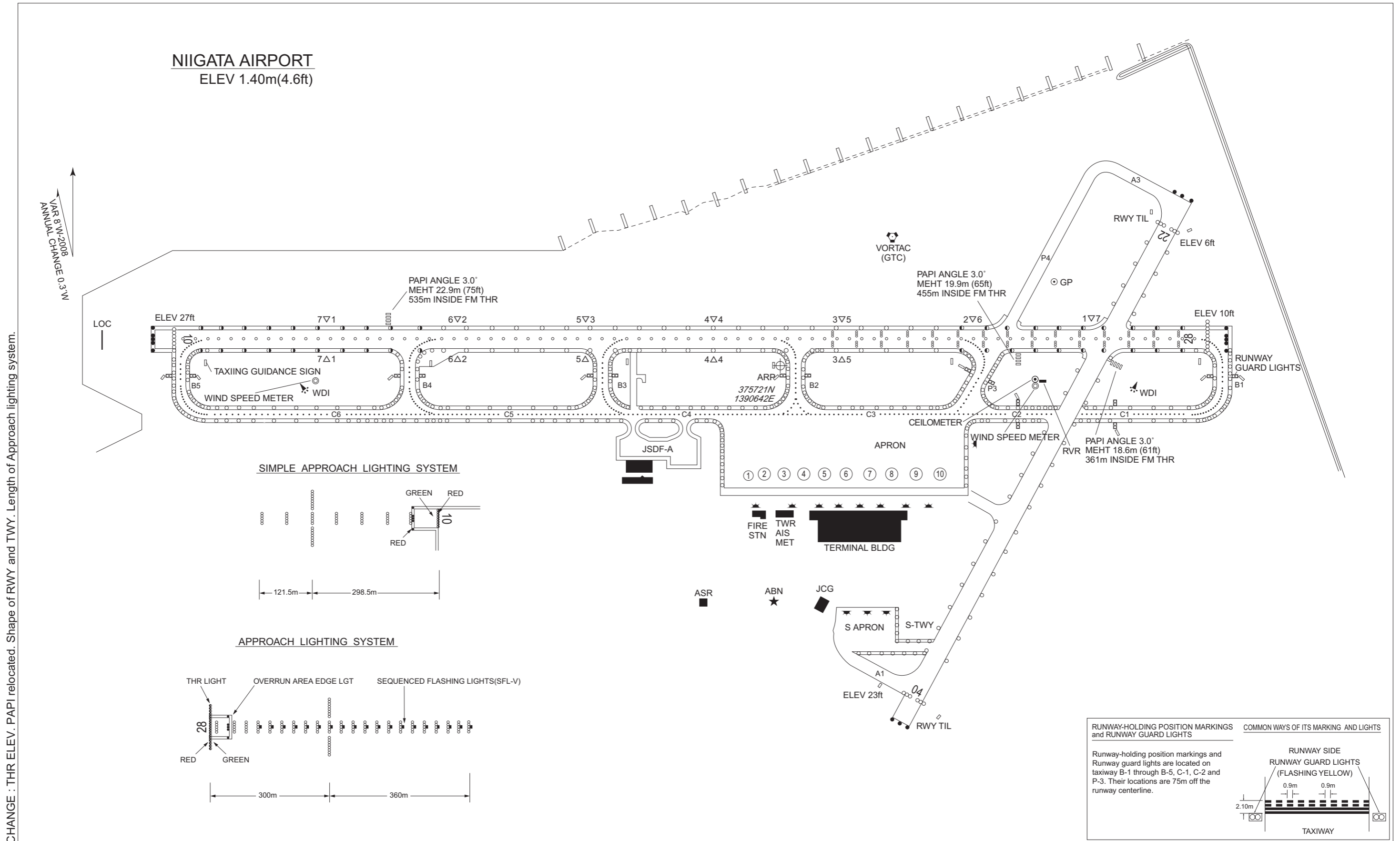

RJSN / NIIGATA

AD CHART

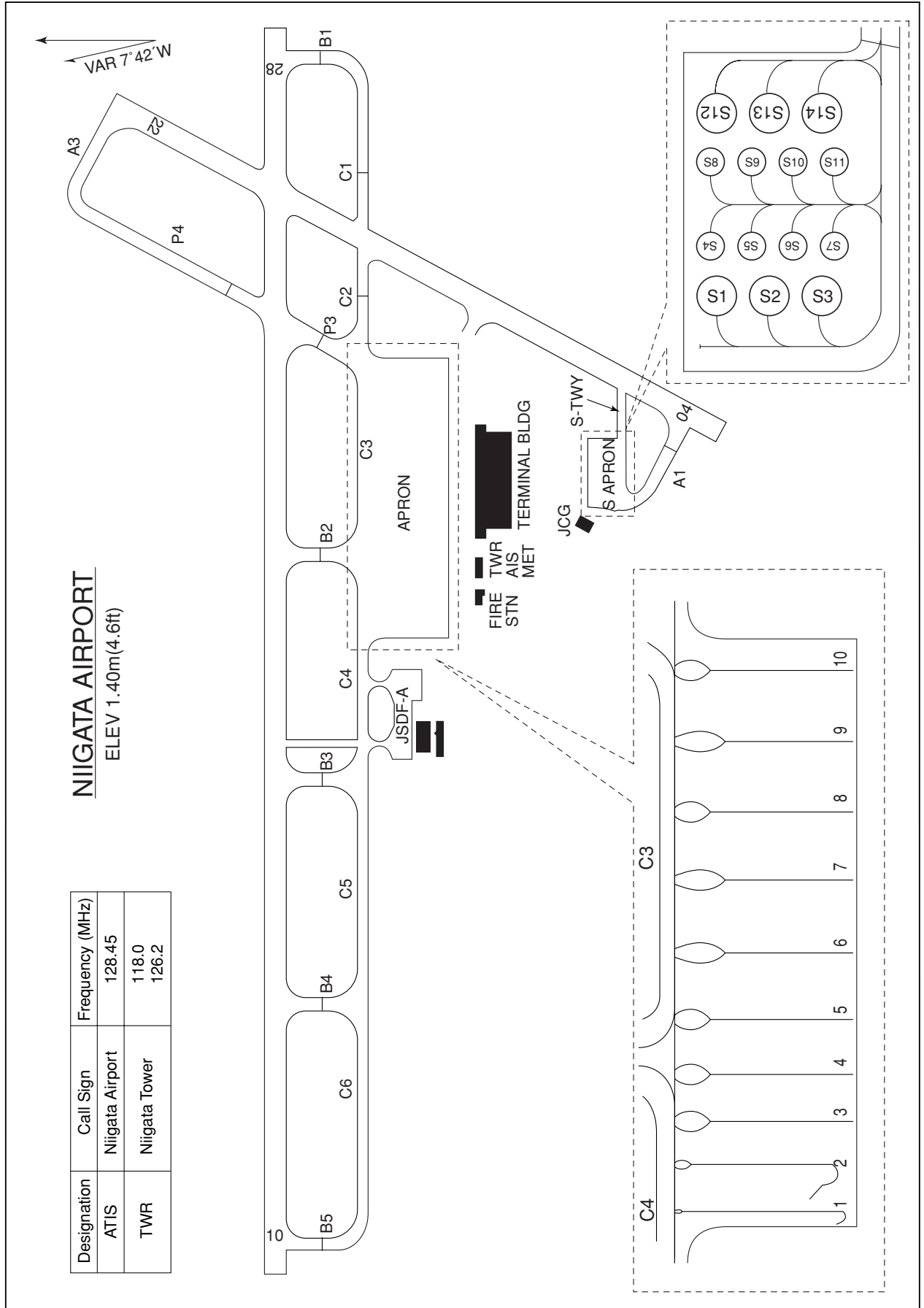

**NIIGATA AIRPORT**

ELEV 1.40m (4.6ft)

Designation	Call Sign	Frequency (MHz)
ATIS	Niigata Airport	128.45
TWR	Niigata Tower	118.0 126.2

DIMENSIONS AND ELEVATIONS IN FEET BEARINGS ARE MAGNETIC  
Transverse Mercator Projection

AERODROME OBSTACLE CHART-ICAO  
TYPE A (OPERATING LIMITATIONS)

MAGNETIC VARIATION 9°W - DEC 2022

NIIGATA AIRPORT  
RWY : 10/28

DECLARED DISTANCES		
RWY 10		RWY 28
2500	TAKE OFF RUN AVAILABLE	2500
2500	TAKE OFF DISTANCE AVAILABLE	2500
2500	ACCELERATE STOP DISTANCE AVAILABLE	2500
2500	LANDING DISTANCE AVAILABLE	2500

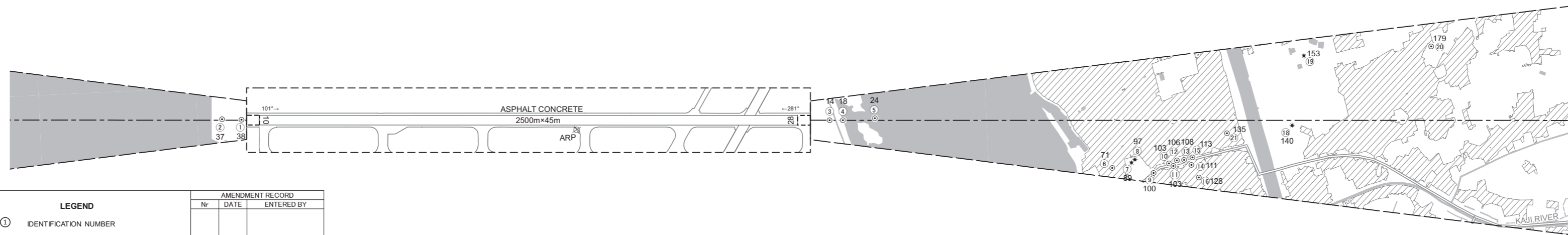
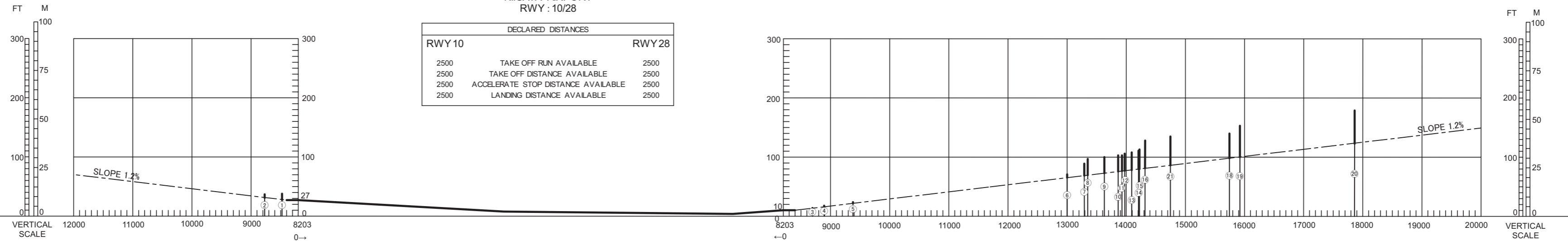

LEGEND		AMENDMENT RECORD		
		Nr	DATE	ENTERED BY
①	IDENTIFICATION NUMBER			
⊙	POLE, TOWER, SPIRE, ANTENNA, ETC			
*	TREE			
—+—+—	RAILROAD			
—~—~—	RIVER			
△	TRIANGULATION POINT			
★	AERONAUTICAL GROUND LIGHT			
■	BUILDING OR LARGE STRUCTURE			
⋯	CONTOURS(ft)			

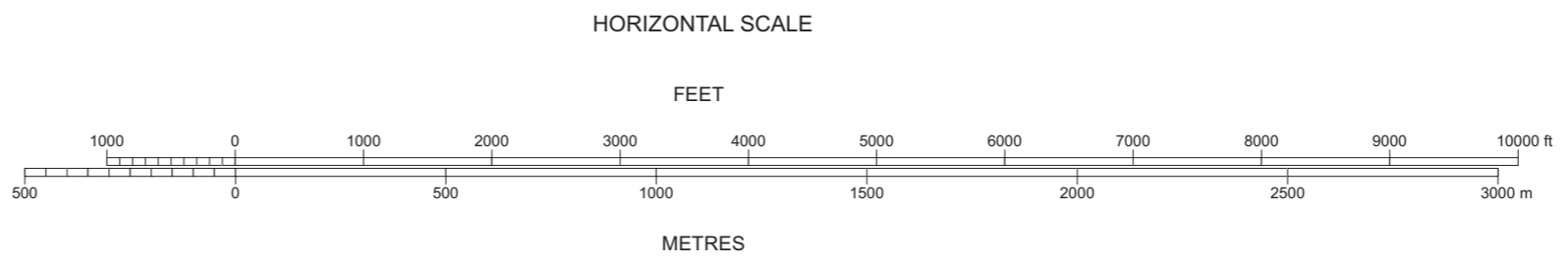

測量法に基づく国土地理院長承認(使用) R 4JHs 286 国土数値情報 (緊急輸送道路)

CHANGE: Update

DIMENSIONS AND ELEVATIONS IN FEET BEARINGS ARE MAGNETIC  
Transverse Mercator Projection

AERODROME OBSTACLE CHART-ICAO  
TYPE B



CHANGE:Update

STANDARD DEPARTURE CHART-INSTRUMENT

RJSN / NIIGATA

SID

OKESA SEVEN DEPARTURE

- RWY 04 : Turn left HDG 245°...
- RWY 10 : Climb RWY HDG to 500FT, turn left HDG 245°...
- RWY 22 : Climb RWY HDG to 800FT, turn left...
- RWY 28 : Climb RWY HDG to 500FT, turn right...  
 ...to intercept and proceed via GTC R290 to OKESA.

NAEBA TRANSITION

From over OKESA, turn left to intercept and proceed via GTC 32.0DME counterclockwise ARC, turn right to intercept and proceed via GTC R223 to NAEBA.

HAKBA TRANSITION

From over OKESA, turn left to intercept and proceed via GTC 32.0DME counterclockwise ARC, turn right to intercept and proceed via GTC R244 to HAKBA.

CHANGE : PROC renamed(OKESA SEVEN DEPARTURE). PROC course.

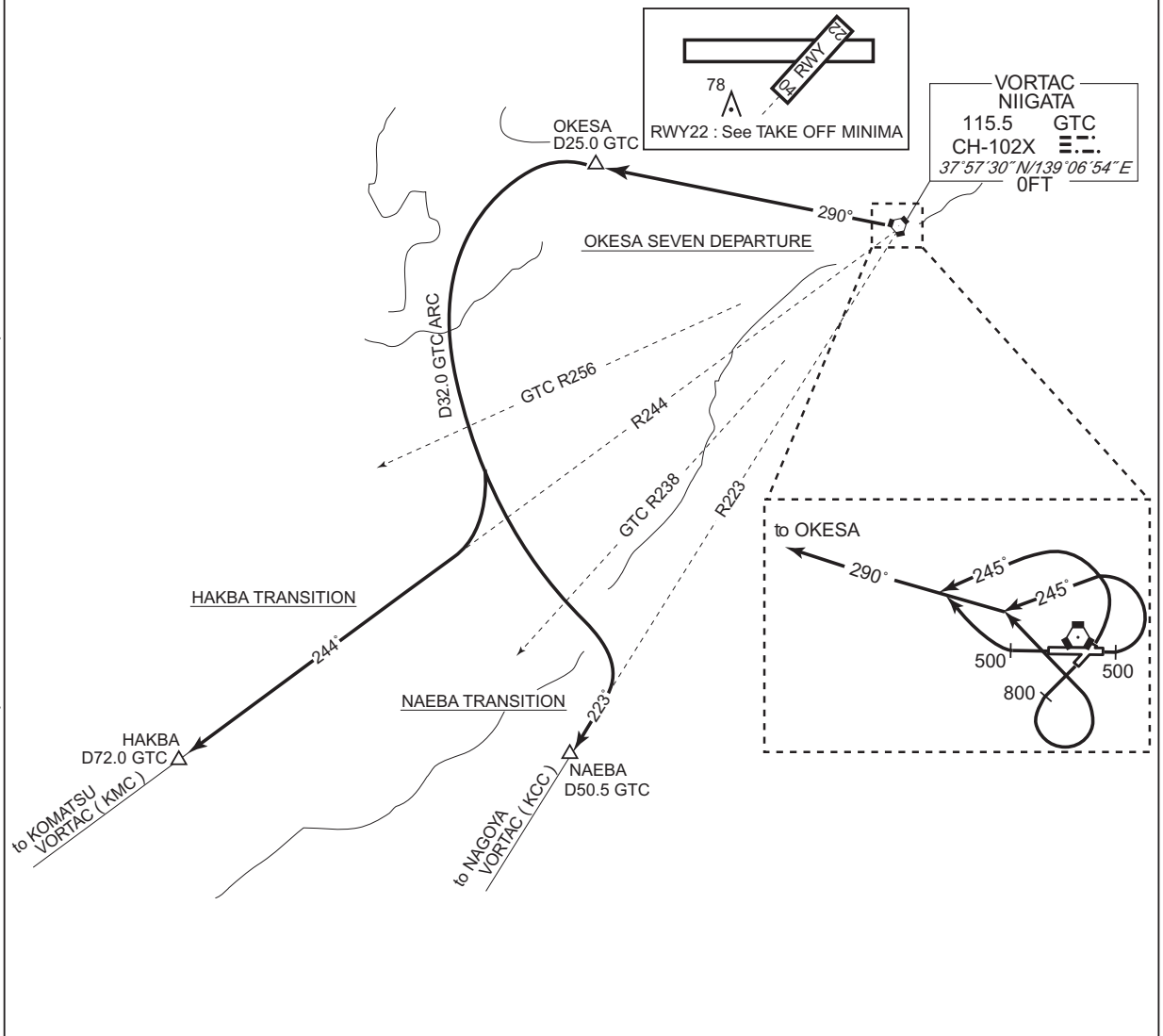

STANDARD DEPARTURE CHART-INSTRUMENT

RJSN / NIIGATA

SID

NIIGATA REVERSAL SEVEN DEPARTURE

- RWY 04 : Turn left...
- RWY 10 : Climb RWY HDG to 500FT, turn left...
- RWY 22 : Climb RWY HDG to 800FT, turn left...
- RWY 28 : Climb RWY HDG to 700FT, turn right...  
...direct to GTC VORTAC.  
Cross GTC VORTAC at or above 3000FT.

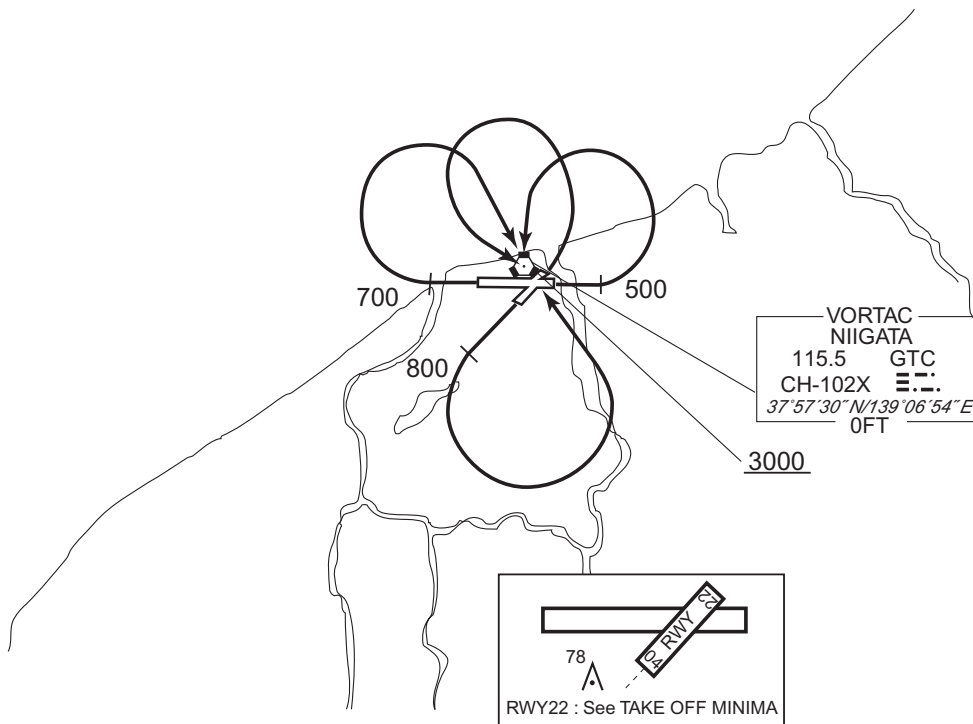

CHANGE : PROC renamed. ALT restriction.



STANDARD DEPARTURE CHART-INSTRUMENT

RJSN / NIIGATA

RNAV SID

SASAGA THREE DEPARTURE

RNP1

Note GNSS required.

VAR 9°W

CHANGE : Navigation Specification(Basic RNP1 → RNP1).

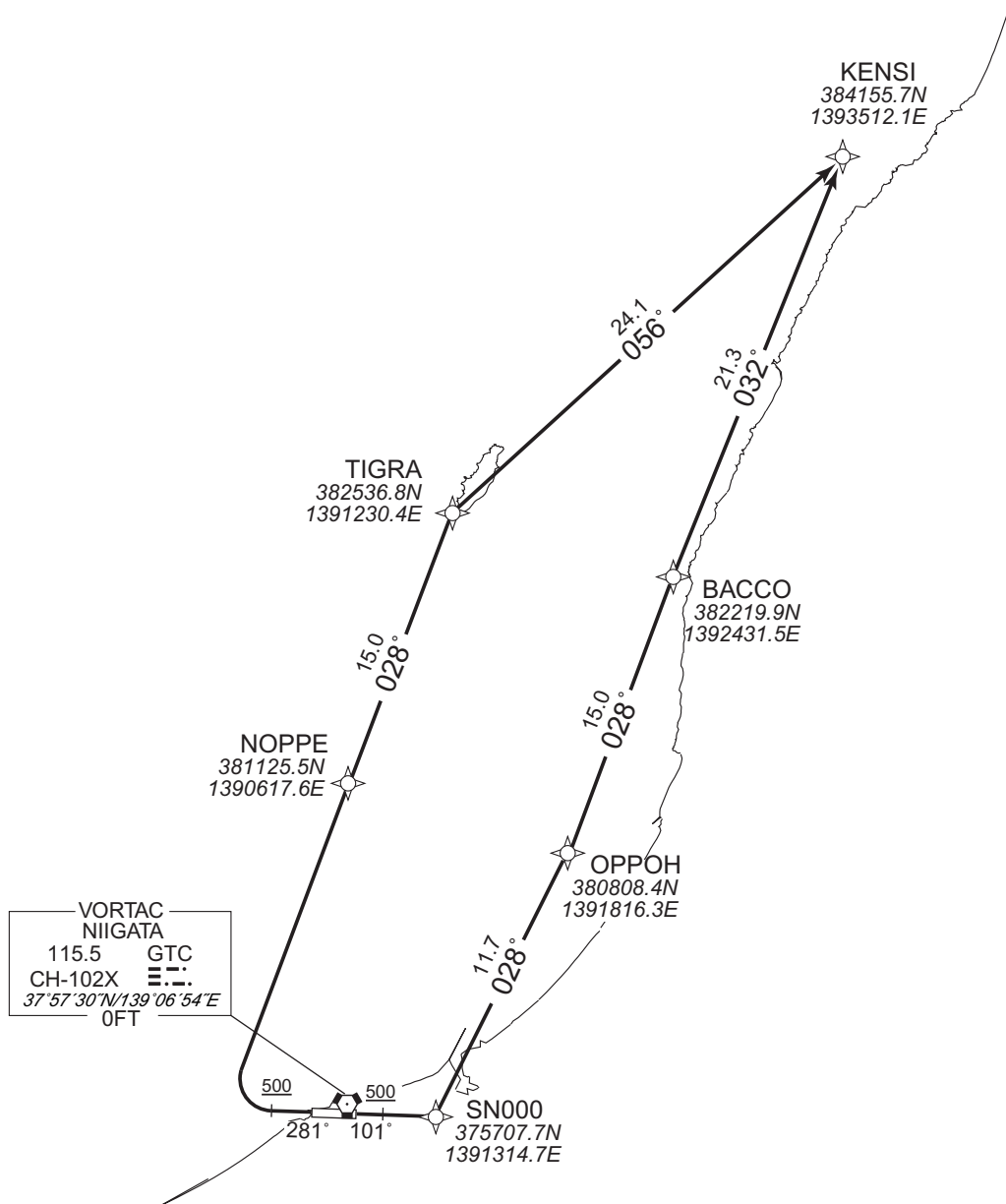

RWY10 : Climb on HDG101° at or above 500FT, direct to SN000, to OPPOH, to BACCO, to KENSI.  
RWY28 : Climb on HDG281° at or above 500FT, turn right direct to NOPEN, to TIGRA, to KENSI.

NOTE RWY10 : 5.0% climb gradient required up to 500FT.

## STANDARD DEPARTURE CHART-INSTRUMENT

RJSN / NIIGATA

RNAV SID

SASAGA THREE DEPARTURE

## RWY10

Serial Number	Path Descriptor	Waypoint Identifier	Fly Over	Course °M(°T)	Magnetic Variation	Distance (NM)	Turn Direction	Altitude (FT)	Speed (KIAS)	Vertical Angle	Navigation Specification
001	VA	-	-	101 (092.7)	-8.6	-	-	+500	-	-	RNP1
002	DF	SN000	-	-	-8.6	-	-	-	-	-	RNP1
003	TF	OPPOH	-	028 (019.7)	-8.6	11.7	-	-	-	-	RNP1
004	TF	BACCO	-	028 (019.1)	-8.6	15.0	-	-	-	-	RNP1
005	TF	KENSI	-	032 (023.0)	-8.6	21.3	-	-	-	-	RNP1

## RWY28

Serial Number	Path Descriptor	Waypoint Identifier	Fly Over	Course °M(°T)	Magnetic Variation	Distance (NM)	Turn Direction	Altitude (FT)	Speed (KIAS)	Vertical Angle	Navigation Specification
001	VA	-	-	281 (272.7)	-8.6	-	-	+500	-	-	RNP1
002	DF	NOPPE	-	-	-8.6	-	R	-	-	-	RNP1
003	TF	TIGRA	-	028 (018.9)	-8.6	15.0	-	-	-	-	RNP1
004	TF	KENSI	-	056 (047.3)	-8.6	24.1	-	-	-	-	RNP1

CHANGE : Navigation Specification(Basic RNP1 → RNP1).

STANDARD DEPARTURE CHART-INSTRUMENT

RJSN / NIIGATA

RNAV SID and TRANSITION

<b>MOKBA TWO DEPARTURE</b> KARIWA TRANSITION / TERAD TRANSITION / VIKET TRANSITION	<b>RNP1</b>
---	-------------

Note GNSS required.

VAR 9°W

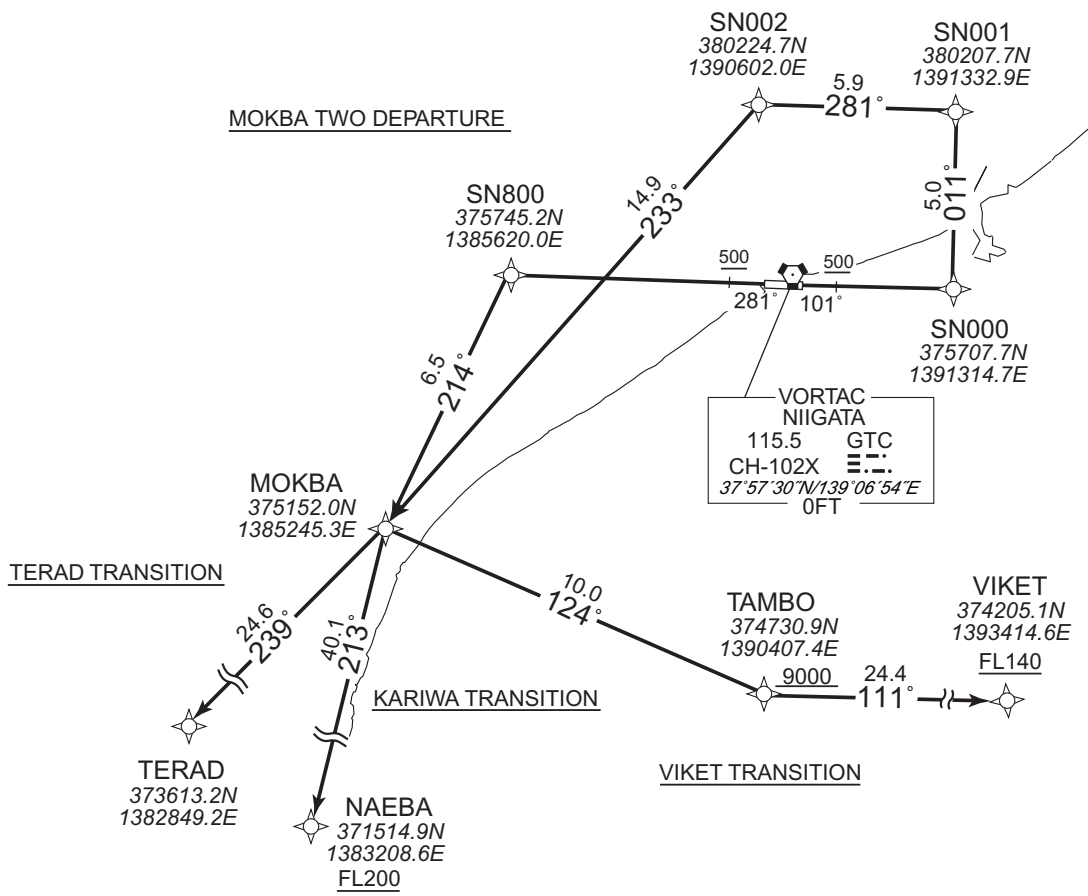

CHANGE : Navigation Specification(Basic RNP1 → RNP1).

**MOKBA TWO DEPARTURE**  
 RWY10 : Climb on HDG101° at or above 500FT, direct to SN000, to SN001, to SN002, to MOKBA.  
 RWY28 : Climb on HDG281° at or above 500FT, direct to SN800, to MOKBA.  
 NOTE RWY10 : 5.0% climb gradient required up to 500FT.

**KARIWA TRANSITION**  
 From MOKBA, to NAEBA at or above FL200.

**TERAD TRANSITION**  
 From MOKBA, to TERAD.

**VIKET TRANSITION**  
 From MOKBA, to TAMBO at or above 9000FT, to VIKET at or above FL140.

## STANDARD DEPARTURE CHART-INSTRUMENT

RJSN / NIIGATA

RNAV SID and TRANSITION

MOKBA TWO DEPARTURE

## RWY10

Serial Number	Path Descriptor	Waypoint Identifier	Fly Over	Course °M(°T)	Magnetic Variation	Distance (NM)	Turn Direction	Altitude (FT)	Speed (KIAS)	Vertical Angle	Navigation Specification
001	VA	-	-	101 (092.7)	-8.6	-	-	+500	-	-	RNP1
002	DF	SN000	-	-	-8.6	-	-	-	-	-	RNP1
003	TF	SN001	-	011 (002.7)	-8.6	5.0	-	-	-	-	RNP1
004	TF	SN002	-	281 (272.8)	-8.6	5.9	-	-	-	-	RNP1
005	TF	MOKBA	-	233 (224.9)	-8.6	14.9	-	-	-	-	RNP1

## RWY28

Serial Number	Path Descriptor	Waypoint Identifier	Fly Over	Course °M(°T)	Magnetic Variation	Distance (NM)	Turn Direction	Altitude (FT)	Speed (KIAS)	Vertical Angle	Navigation Specification
001	VA	-	-	281 (272.7)	-8.6	-	-	+500	-	-	RNP1
002	DF	SN800	-	-	-8.6	-	-	-	-	-	RNP1
003	TF	MOKBA	-	214 (205.6)	-8.6	6.5	-	-	-	-	RNP1

KARIWA TRANSITION

Serial Number	Path Descriptor	Waypoint Identifier	Fly Over	Course °M(°T)	Magnetic Variation	Distance (NM)	Turn Direction	Altitude (FT)	Speed (KIAS)	Vertical Angle	Navigation Specification
001	IF	MOKBA	-	-	-8.6	-	-	-	-	-	RNP1
002	TF	NAEBA	-	213 (204.2)	-8.6	40.1	-	+FL200	-	-	RNP1

TERAD TRANSITION

Serial Number	Path Descriptor	Waypoint Identifier	Fly Over	Course °M(°T)	Magnetic Variation	Distance (NM)	Turn Direction	Altitude (FT)	Speed (KIAS)	Vertical Angle	Navigation Specification
001	IF	MOKBA	-	-	-8.6	-	-	-	-	-	RNP1
002	TF	TERAD	-	239 (230.5)	-8.6	24.6	-	-	-	-	RNP1

VIKET TRANSITION

Serial Number	Path Descriptor	Waypoint Identifier	Fly Over	Course °M(°T)	Magnetic Variation	Distance (NM)	Turn Direction	Altitude (FT)	Speed (KIAS)	Vertical Angle	Navigation Specification
001	IF	MOKBA	-	-	-8.6	-	-	-	-	-	RNP1
002	TF	TAMBO	-	124 (115.8)	-8.6	10.0	-	+9000	-	-	RNP1
003	TF	VIKET	-	111 (102.7)	-8.6	24.4	-	+FL140	-	-	RNP1

CHANGE : Navigation Specification(Basic RNP1 → RNP1).

STANDARD DEPARTURE CHART-INSTRUMENT

RJSN / NIIGATA

RNAV SID

SUKOB ONE DEPARTURE

RNAV 1

NOTE 1 ) DME/DME/IRU or GNSS required. ※The aircraft equipped with only DME/DME/IRU must be able to update its position without delay at the starting point of take-off roll. 2 ) RADAR service required.	Critical DME	RWY10 : GTC : 10.0NM to SUKOB - SUKOB NTE : 10.0NM to SUKOB - SUKOB RWY28 : GTC : 15.0NM to SUKOB - SUKOB NTE : 15.0NM to SUKOB - SUKOB
	DME GAP	RWY10 : DER - 10.0NM to SUKOB RWY28 : DER - 15.0NM to SUKOB
	Inappropriate Nav aids	See AD1.1.6.10.3. Inappropriate NAVAIDS for RNAV1.

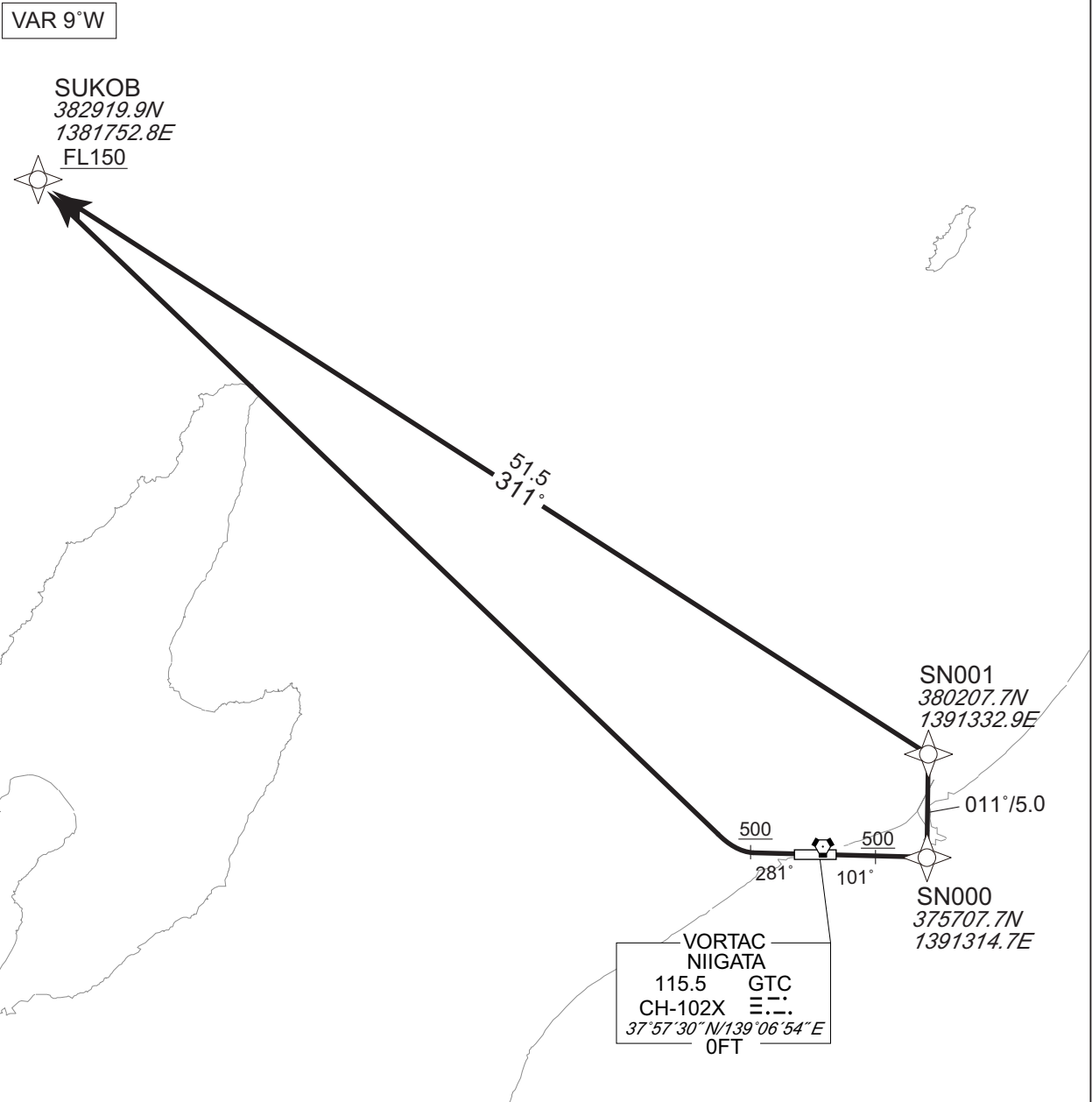

CHANGE : Description of VAR.

RWY10 : Climb on HDG101° at or above 500FT, direct to SN000, to SN001, to SUKOB at or above FL150.  
 RWY28 : Climb on HDG281° at or above 500FT, turn right direct to SUKOB at or above FL150.  
 Note RWY10 : 5.0% climb gradient required up to 500FT.

## STANDARD DEPARTURE CHART-INSTRUMENT

RJSN/ NIIGATA

RNAV SID

SUKOB ONE DEPARTURE

RWY10

Serial Number	Path Descriptor	Waypoint Identifier	Fly Over	Course °M(°T)	Magnetic Variation	Distance (NM)	Turn Direction	Altitude (FT)	Speed (KIAS)	Vertical Angle	Navigation Specification
001	VA	—	—	101 (092.7)	-8.6	—	—	+500	—	—	RNAV1
002	DF	SN000	—	—	-8.6	—	—	—	—	—	RNAV1
003	TF	SN001	—	011 (002.7)	-8.6	5.0	—	—	—	—	RNAV1
004	TF	SUKOB	—	311 (302.2)	-8.6	51.5	—	+FL150	—	—	RNAV1

RWY28

Serial Number	Path Descriptor	Waypoint Identifier	Fly Over	Course °M(°T)	Magnetic Variation	Distance (NM)	Turn Direction	Altitude (FT)	Speed (KIAS)	Vertical Angle	Navigation Specification
001	VA	—	—	281 (272.7)	-8.6	—	—	+500	—	—	RNAV1
002	DF	SUKOB	—	—	-8.6	—	R	+FL150	—	—	RNAV1

CHANGE : New PROC.

STANDARD ARRIVAL CHART-INSTRUMENT

RJSN / NIIGATA

RNAV STAR RWY28

INAHO EAST ARRIVAL GOSEN EAST ARRIVAL MAGNA EAST ARRIVAL TERAD EAST ARRIVAL	RNAV1
--	-------

Note 1 ) GNSS required.  
 2 ) RADAR service required.

VAR 9°W

CHANGE : Description of VAR.

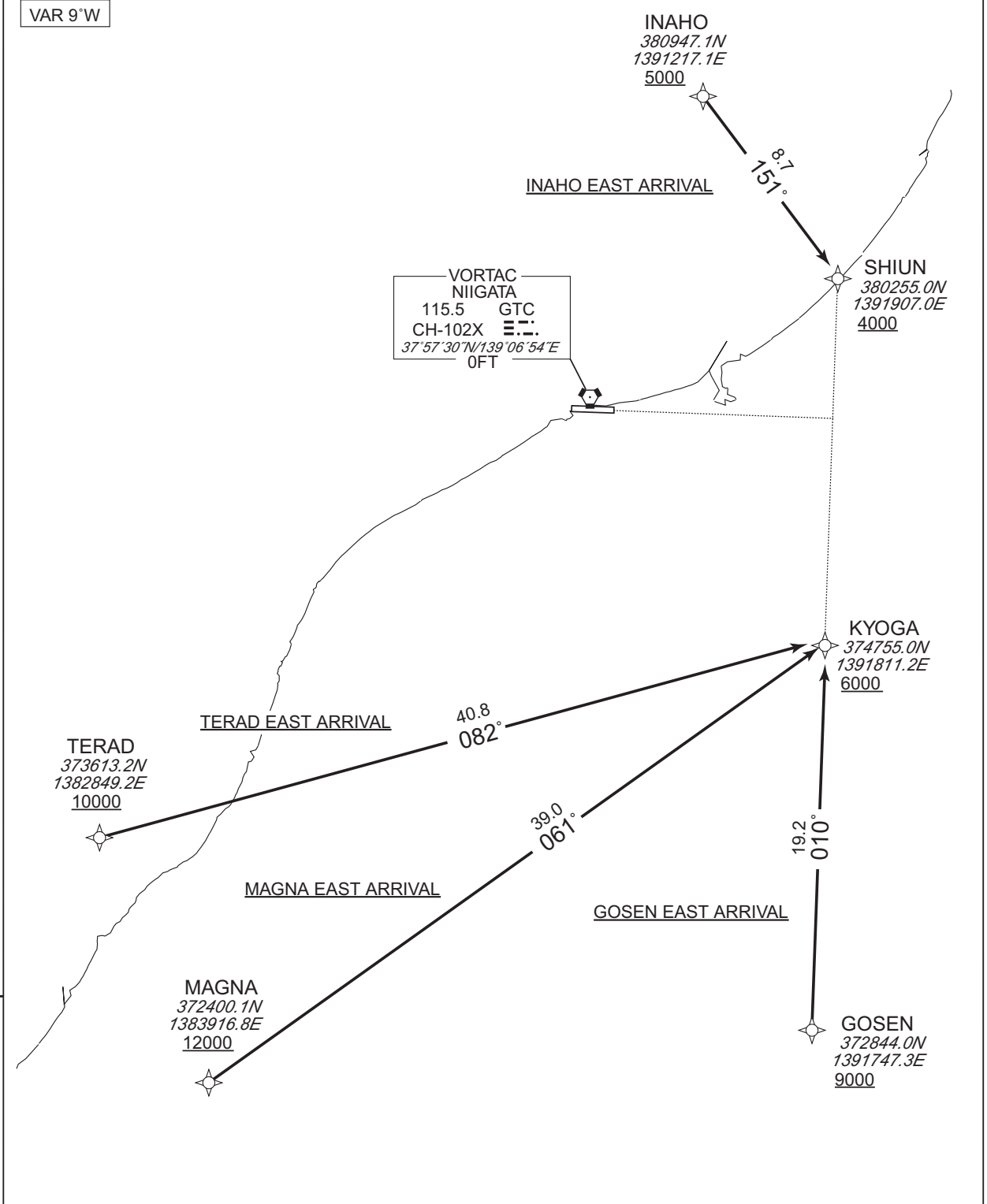

## STANDARD ARRIVAL CHART-INSTRUMENT

RJSN / NIIGATA

RNAV STAR RWY28

INAHO EAST ARRIVAL

From INAHO at or above 5000FT, to SHIUN at or above 4000FT.

Critical DME	-
DME GAP	INAHO - SHIUN
Inappropriate Nav aids	See AD1.1.6.10.3. Inappropriate NAVAIDs for RNAV1

Serial Number	Path Descriptor	Waypoint Identifier	Fly Over	Course °M(°T)	Magnetic Variation	Distance (NM)	Turn Direction	Altitude (FT)	Speed (KIAS)	Vertical Angle	Navigation Specification
001	IF	INAHO	-	-	-8.6	-	-	+5000	-	-	RNAV1
002	TF	SHIUN	-	151 (141.9)	-8.6	8.7	-	+4000	-	-	RNAV1

GOSEN EAST ARRIVAL

From GOSEN at or above 9000FT, to KYOGA at or above 6000FT.

Critical DME	-
DME GAP	GOSEN - KYOGA
Inappropriate Nav aids	See AD1.1.6.10.3. Inappropriate NAVAIDs for RNAV1

Serial Number	Path Descriptor	Waypoint Identifier	Fly Over	Course °M(°T)	Magnetic Variation	Distance (NM)	Turn Direction	Altitude (FT)	Speed (KIAS)	Vertical Angle	Navigation Specification
001	IF	GOSEN	-	-	-8.6	-	-	+9000	-	-	RNAV1
002	TF	KYOGA	-	010 (000.9)	-8.6	19.2	-	+6000	-	-	RNAV1

MAGNA EAST ARRIVAL

From MAGNA at or above 12000FT, to KYOGA at or above 6000FT.

Critical DME	GTC:MAGNA - 10.0NM to KYOGA NTE:MAGNA - 10.0NM to KYOGA
DME GAP	10.0NM to KYOGA - KYOGA
Inappropriate Nav aids	See AD1.1.6.10.3. Inappropriate NAVAIDs for RNAV1

Serial Number	Path Descriptor	Waypoint Identifier	Fly Over	Course °M(°T)	Magnetic Variation	Distance (NM)	Turn Direction	Altitude (FT)	Speed (KIAS)	Vertical Angle	Navigation Specification
001	IF	MAGNA	-	-	-8.6	-	-	+12000	-	-	RNAV1
002	TF	KYOGA	-	061 (052.0)	-8.6	39.0	-	+6000	-	-	RNAV1

TERAD EAST ARRIVAL

From TERAD at or above 10000FT, to KYOGA at or above 6000FT.

Critical DME	-
DME GAP	TERAD - KYOGA
Inappropriate Nav aids	See AD1.1.6.10.3. Inappropriate NAVAIDs for RNAV1

Serial Number	Path Descriptor	Waypoint Identifier	Fly Over	Course °M(°T)	Magnetic Variation	Distance (NM)	Turn Direction	Altitude (FT)	Speed (KIAS)	Vertical Angle	Navigation Specification
001	IF	TERAD	-	-	-8.6	-	-	+10000	-	-	RNAV1
002	TF	KYOGA	-	082 (073.1)	-8.6	40.8	-	+6000	-	-	RNAV1

CHANGE : VAR. PROC course.



STANDARD ARRIVAL CHART-INSTRUMENT

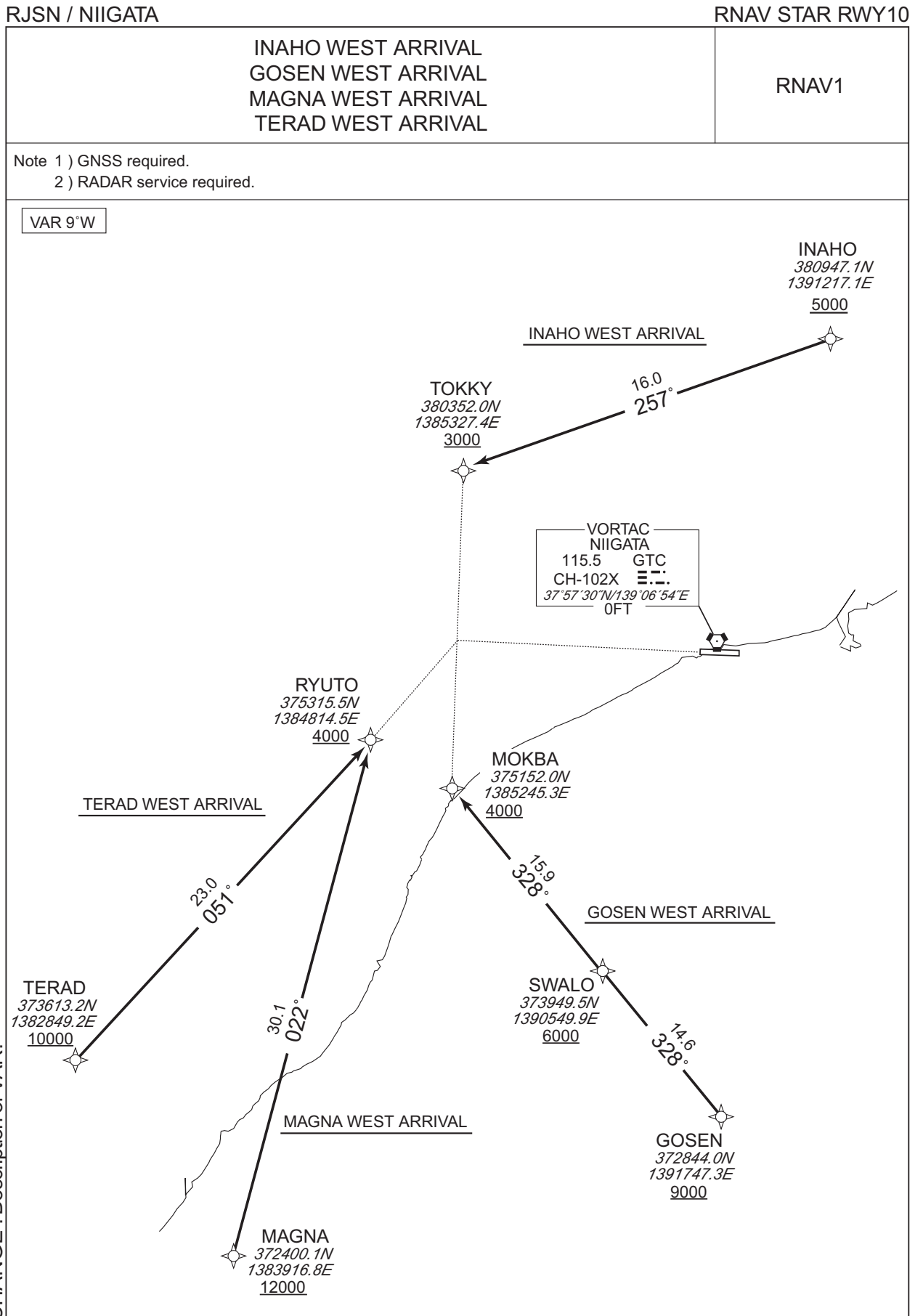

STANDARD ARRIVAL CHART-INSTRUMENT

RJSN / NIIGATA

RNAV STAR RWY10

INAHO WEST ARRIVAL

From INAHO at or above 5000FT, to TOKKY at or above 3000FT.

Critical DME	-
DME GAP	INAHO - TOKKY
Inappropriate Nav aids	See AD1.1.6.10.3. Inappropriate NAVAIDs for RNAV1

Serial Number	Path Descriptor	Waypoint Identifier	Fly Over	Course °M(°T)	Magnetic Variation	Distance (NM)	Turn Direction	Altitude (FT)	Speed (KIAS)	Vertical Angle	Navigation Specification
001	IF	INAHO	-	-	-8.6	-	-	+5000	-	-	RNAV1
002	TF	TOKKY	-	257 (248.3)	-8.6	16.0	-	+3000	-	-	RNAV1

GOSEN WEST ARRIVAL

From GOSEN at or above 9000FT, to SWALO at or above 6000FT, to MOKBA at or above 4000FT.

Critical DME	-
DME GAP	GOSEN - MOKBA
Inappropriate Nav aids	See AD1.1.6.10.3. Inappropriate NAVAIDs for RNAV1

Serial Number	Path Descriptor	Waypoint Identifier	Fly Over	Course °M(°T)	Magnetic Variation	Distance (NM)	Turn Direction	Altitude (FT)	Speed (KIAS)	Vertical Angle	Navigation Specification
001	IF	GOSEN	-	-	-8.6	-	-	+9000	-	-	RNAV1
002	TF	SWALO	-	328 (319.5)	-8.6	14.6	-	+6000	-	-	RNAV1
003	TF	MOKBA	-	328 (319.4)	-8.6	15.9	-	+4000	-	-	RNAV1

MAGNA WEST ARRIVAL

From MAGNA at or above 12000FT, to RYUTO at or above 4000FT.

Critical DME	GTC:MAGNA - 15.0NM to RYUTO NTE:MAGNA - 15.0NM to RYUTO
DME GAP	15.0NM to RYUTO - RYUTO
Inappropriate Nav aids	See AD1.1.6.10.3. Inappropriate NAVAIDs for RNAV1

Serial Number	Path Descriptor	Waypoint Identifier	Fly Over	Course °M(°T)	Magnetic Variation	Distance (NM)	Turn Direction	Altitude (FT)	Speed (KIAS)	Vertical Angle	Navigation Specification
001	IF	MAGNA	-	-	-8.6	-	-	+12000	-	-	RNAV1
002	TF	RYUTO	-	022 (013.6)	-8.6	30.1	-	+4000	-	-	RNAV1

TERAD WEST ARRIVAL

From TERAD at or above 10000FT, to RYUTO at or above 4000FT.

Critical DME	-
DME GAP	TERAD - RYUTO
Inappropriate Nav aids	See AD1.1.6.10.3. Inappropriate NAVAIDs for RNAV1

Serial Number	Path Descriptor	Waypoint Identifier	Fly Over	Course °M(°T)	Magnetic Variation	Distance (NM)	Turn Direction	Altitude (FT)	Speed (KIAS)	Vertical Angle	Navigation Specification
001	IF	TERAD	-	-	-8.6	-	-	+10000	-	-	RNAV1
002	TF	RYUTO	-	051 (041.9)	-8.6	23.0	-	+4000	-	-	RNAV1

CHANGE : VAR. PROC course FM TERAD to RYUTO.

STANDARD ARRIVAL CHART-INSTRUMENT

RJSN / NIIGATA RNAV STAR RWY10

KAETSU ARRIVAL

RNP1

Note GNSS required.

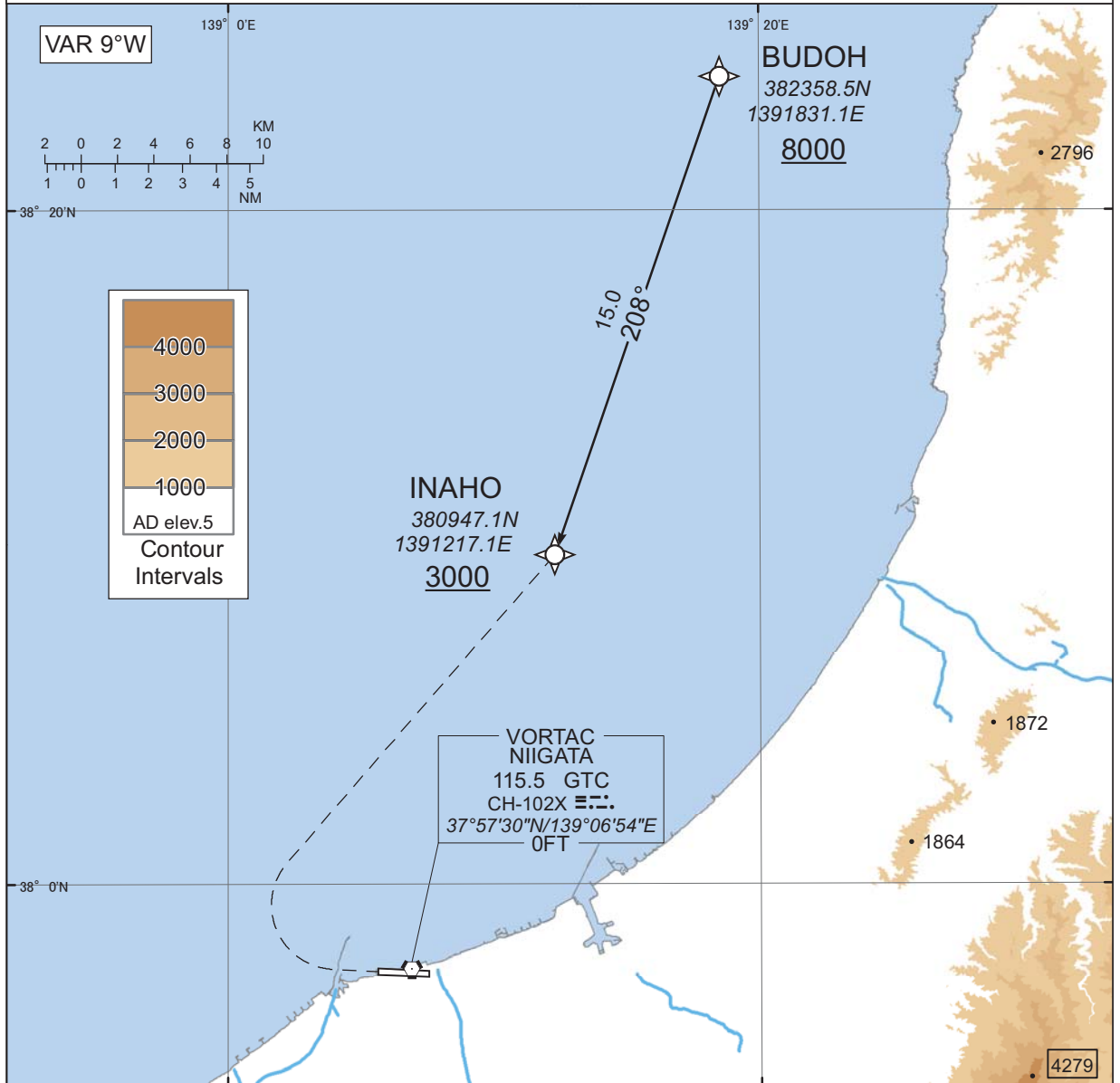

CHANGE : Navigation Specification(Basic RNP1 → RNP1).

From BUDOH at or above 8000FT, to INAHO at or above 3000FT.

Serial Number	Path Descriptor	Waypoint Identifier	Fly Over	Course °M(°T)	Magnetic Variation	Distance (NM)	Turn Direction	Altitude (FT)	Speed (KIAS)	Vertical Angle	Navigation Specification
001	IF	BUDOH	-	208 (199.1)	-8.6	-	-	+8000	-	-	RNP1
002	TF	INAHO	-	-	-8.6	15.0	-	+3000	-	-	RNP1

**INTENTIONALLY LEFT BLANK**

INSTRUMENT APPROACH CHART

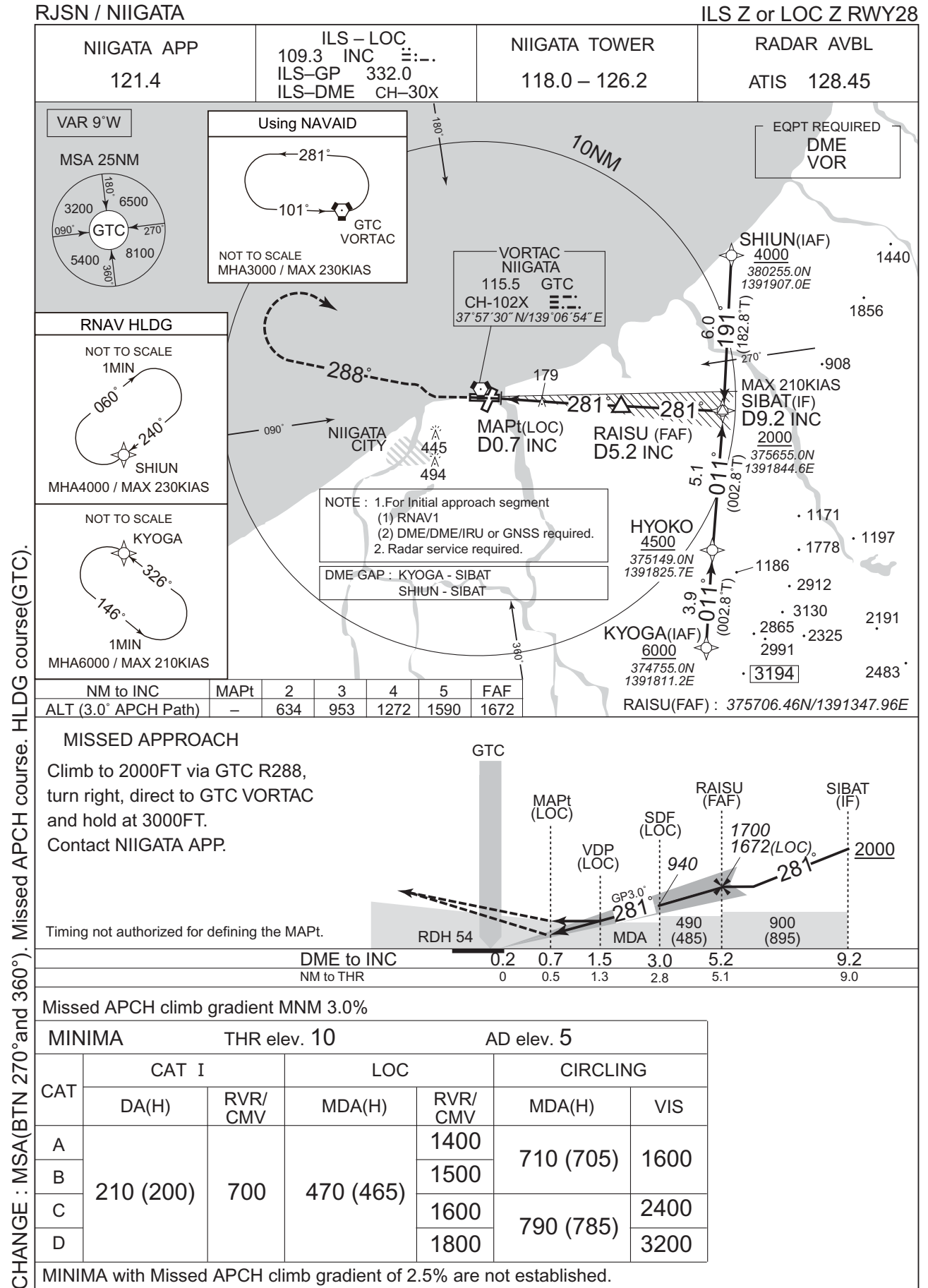

INSTRUMENT APPROACH CHART

RJSN / NIIGATA

ILS Y or LOC Y RWY28

NIIGATA APP 121.4	ILS - LOC 109.3 INC 3:-- ILS-GP 332.0 ILS-DME CH-30X	NIIGATA TOWER 118.0 - 126.2	RADAR AVBL ATIS 128.45
----------------------	---	--------------------------------	---------------------------

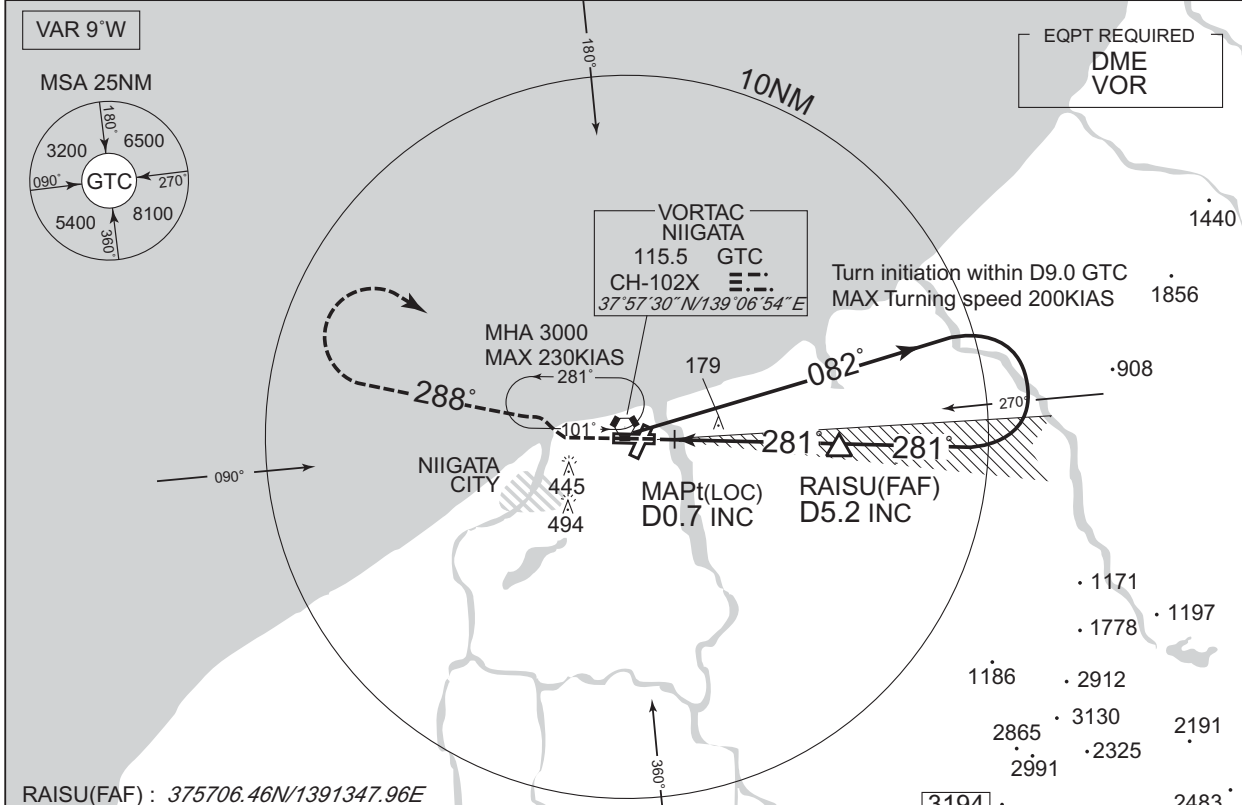

NM to INC	MAPt	2	3	4	5	FAF
ALT (3.0° APCH Path)	-	634	953	1272	1590	1672

MISSED APPROACH

Climb to 2000FT via GTC R288, turn right, direct to GTC VORTAC and hold at 3000FT. Contact NIIGATA APP.

Timing not authorized for defining the MAPt.

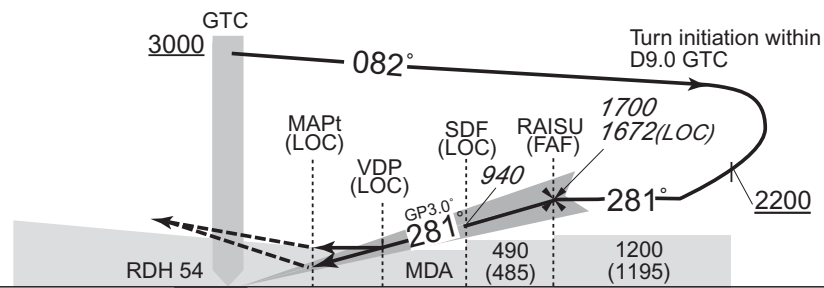

DME to INC	0.2	0.7	1.5	3.0	5.2
NM to THR	0	0.5	1.3	2.8	5.1

Missed APCH climb gradient MNM 3.0%

MINIMA		THR elev. 10		AD elev. 5		
CAT	CAT I	LOC		CIRCLING		
	DA(H)	RVR/CMV	MDA(H)	RVR/CMV	MDA(H) VIS	
A	210 (200)	700	470 (465)	1400	710 (705)	1600
B				1500		
C				1600	790 (785)	2400
D				1800		

MINIMA with Missed APCH climb gradient of 2.5% are not established.

CHANGE : MSA(BTN 270° and 360°). PROC course. Missed APCH course. HLDG course.

INSTRUMENT APPROACH CHART

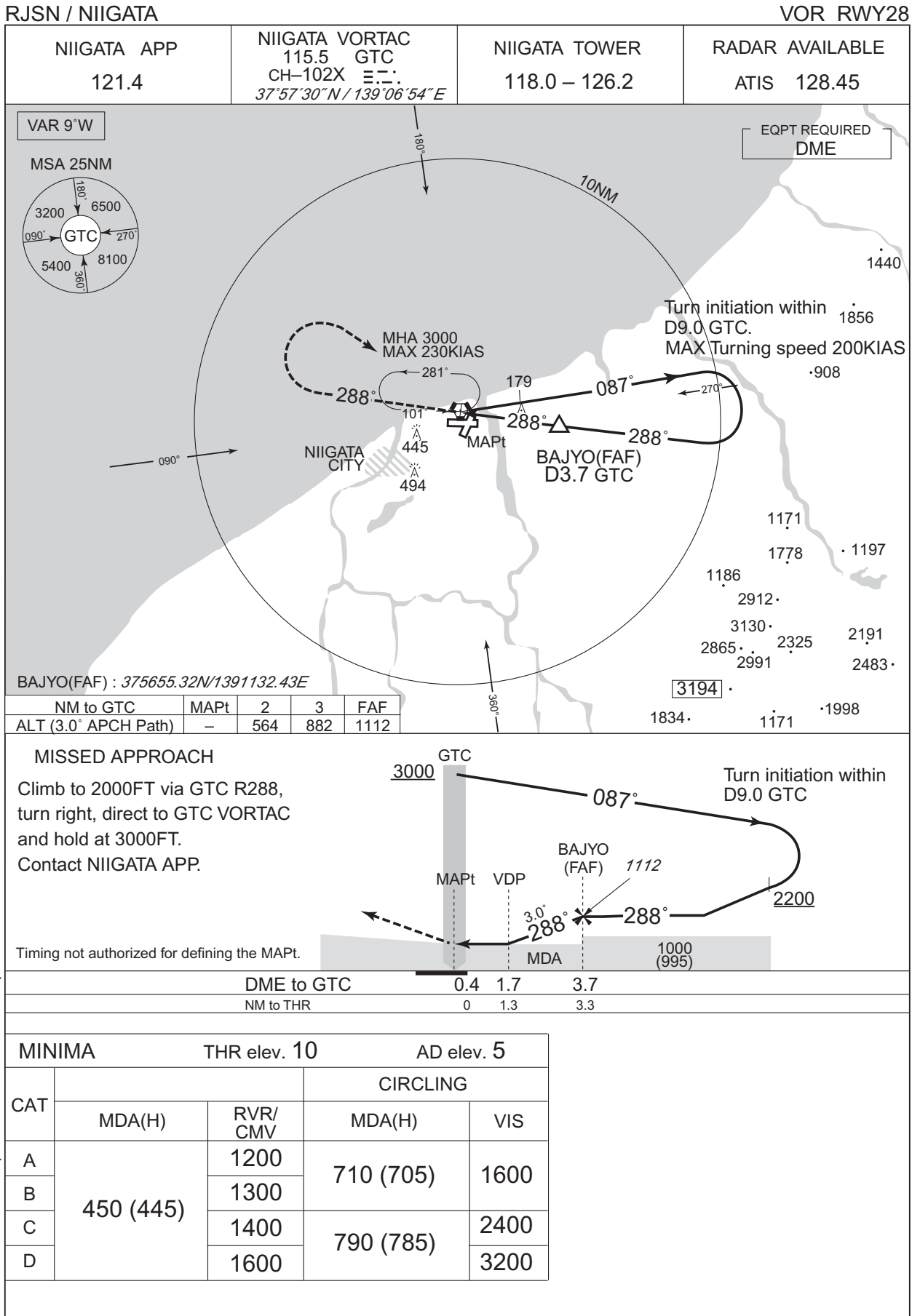

CHANGE : MSA(BTN 270° and 360°). PROC course. Missed APCH course. HLDG course.

INSTRUMENT APPROACH CHART

RJSN / NIIGATA

RNP Z RWY10

NIIGATA APP 121.4	RNP APCH	NIIGATA TOWER 118.0 – 126.2	RADAR AVBL ATIS 128.45
----------------------	----------	--------------------------------	---------------------------

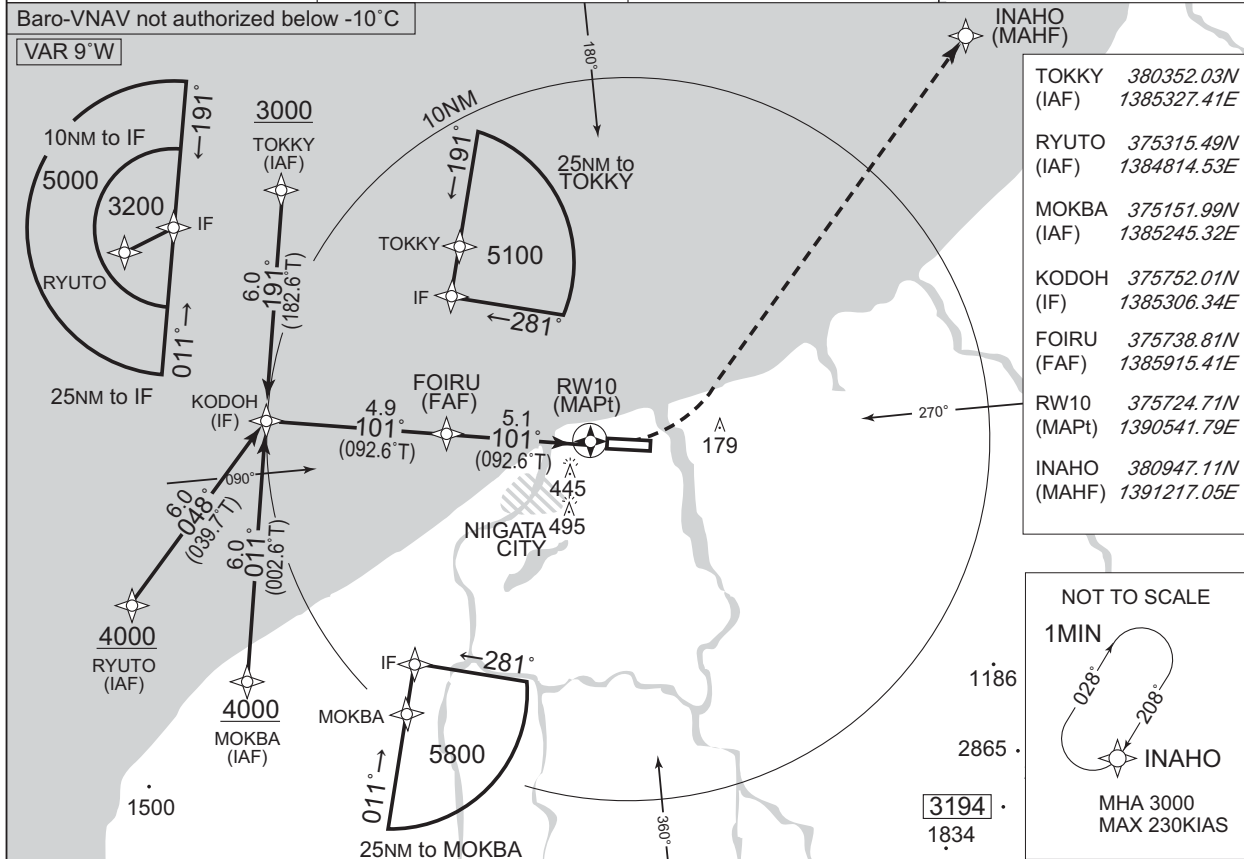

NM To Next Fix	FAF	5	4	3	2	MAPt
ALT (3.0° APCH Path)		1700	1669	1350	1032	713

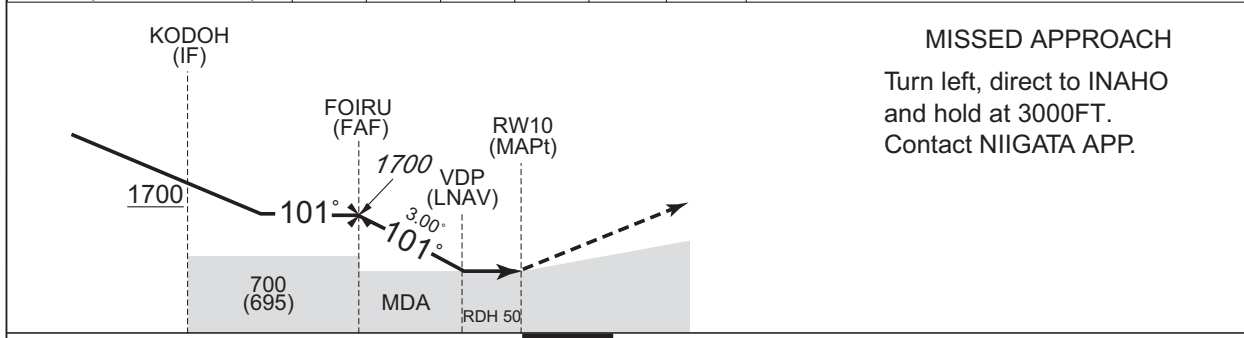

9.9 5.1 1.6 0 NM to THR

MINIMA		THR elev. 27		AD elev. 5		
CAT	LNAV/VNAV		LNAV		CIRCLING	
	DA(H)	CMV	MDA(H)	CMV	MDA(H)	VIS
A	580 (553)	1400	580 (575)	1400	710 (705)	1600
B		1500		1500		
C		1600		1600	790 (785)	2400
D		1800		1800		

CHANGE : PROC renamed.



INSTRUMENT APPROACH CHART

RJSN / NIIGATA RNP Y RWY10(AR)

NIIGATA APP 121.4	RNP AR RF required.	NIIGATA TOWER 118.0 – 126.2	RADAR AVBL ATIS 128.45
----------------------	------------------------	--------------------------------	---------------------------

For uncompensated Baro-VNAV systems, procedure not authorized below -10°C / above 45°C

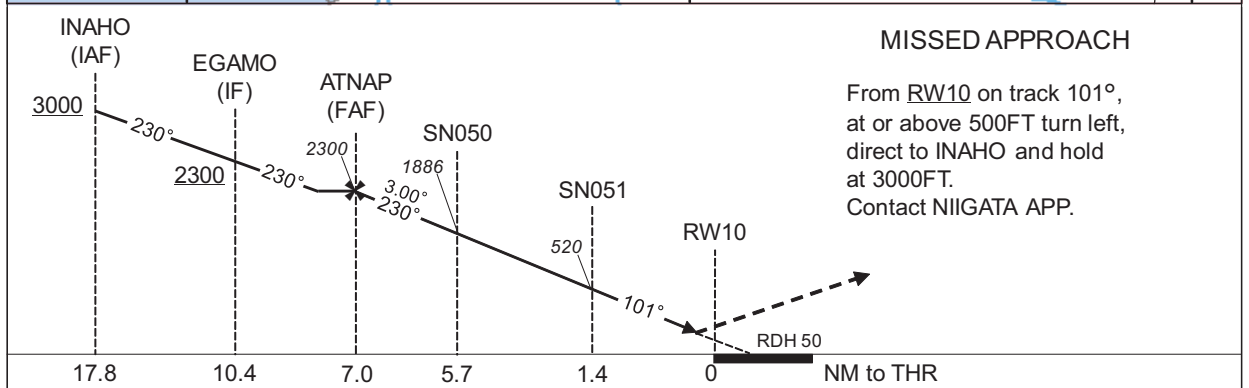
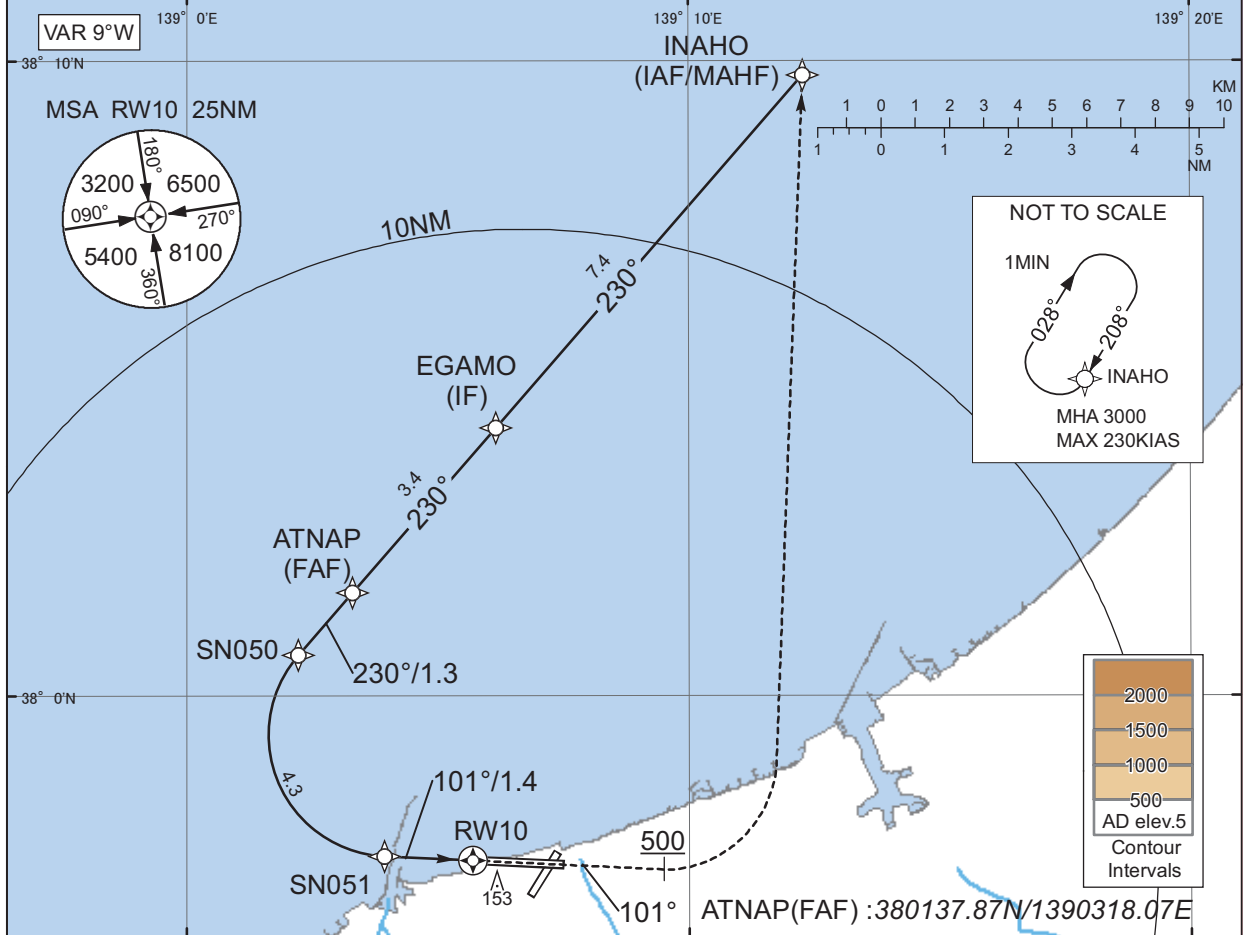

CHANGE : New PROC.

MINIMA	THR elev. 27	AD elev. 5	
	RNP 0.30		
CAT	DA(H)	CMV	
A	-	-	
B	-	-	
C	305(278)	1200	
D	315(288)	1400	

Authorization Required

INSTRUMENT APPROACH CHART

RJSN / NIIGATA

RNP Y RWY10(AR)

Coding Table

Serial Number	Path Descriptor	Waypoint Identifier	Fly Over	Course °M(°T)	Magnetic Variation	Distance (NM)	Turn Direction	Altitude (FT)	Speed (KIAS)	VPA/ RDH (°/FT)	RNP Value
001	IF	INAHO	-	-	-8.6	-	-	+3000	-	-	-
002	TF	EGAMO	-	230 (221.0)	-8.6	7.4	-	+2300	-	-	1.0
003	TF	ATNAP	-	230 (220.9)	-8.6	3.4	-	2300	-	-	1.0
004	TF	SN050	-	230 (220.9)	-8.6	1.3	-	1886	-	-3.00	0.3
005	RF Center: SNRF1 r=1.91NM	SN051	-	-	-8.6	4.3	L	520	-	-3.00	0.3
006	TF	RW10	Y	101 (092.7)	-8.6	1.4	-	77	-	-3.00/50	0.3
007	FA	-	-	101 (092.7)	-8.6	-	-	+500	-	-	1.0
008	DF	INAHO	-	-	-8.6	-	L	3000	-	-	1.0

Path	Waypoint Identifier	Inbound Course °M(°T)	Magnetic Variation	Outbound Time (MIN)	Turn Direction	Minimum Altitude (FT)	Maximum Altitude (FT)	Speed (KIAS)	RNP Value
Hold	INAHO	208 (199.1)	-8.6	1.0 (-14000)	R	3000	FL140	-230 (-14000)	1.0

Waypoint Coordinates

Waypoint Identifier	Coordinates	RF Arc Center Identifier	Coordinates
INAHO	380947.11N / 1391217.05E	SNRF1	375923.46N / 1390402.94E
EGAMO	380413.79N / 1390609.55E		
ATNAP	380137.87N / 1390318.07E		
SN050	380038.89N / 1390213.27E		
SN051	375728.60N / 1390356.21E		
RW10	375724.71N / 1390541.79E		

CHANGE : New PROC.

INSTRUMENT APPROACH CHART

RJSN / NIIGATA

VOR RWY10

NIIGATA APP 121.4	NIIGATA VORTAC 115.5 GTC CH-102X $\equiv \equiv \equiv$ 37°57'30"N / 139°06'54"E	NIIGATA TOWER 118.0 – 126.2	RADAR AVAILABLE ATIS 128.45
----------------------	---	--------------------------------	--------------------------------

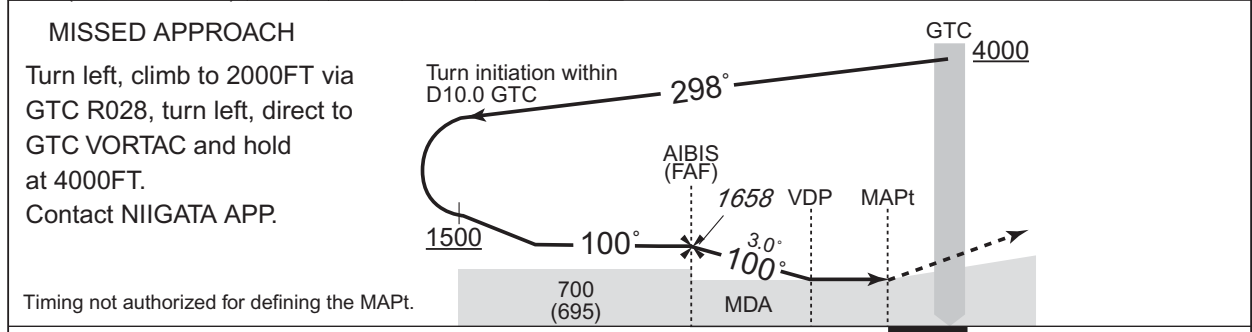
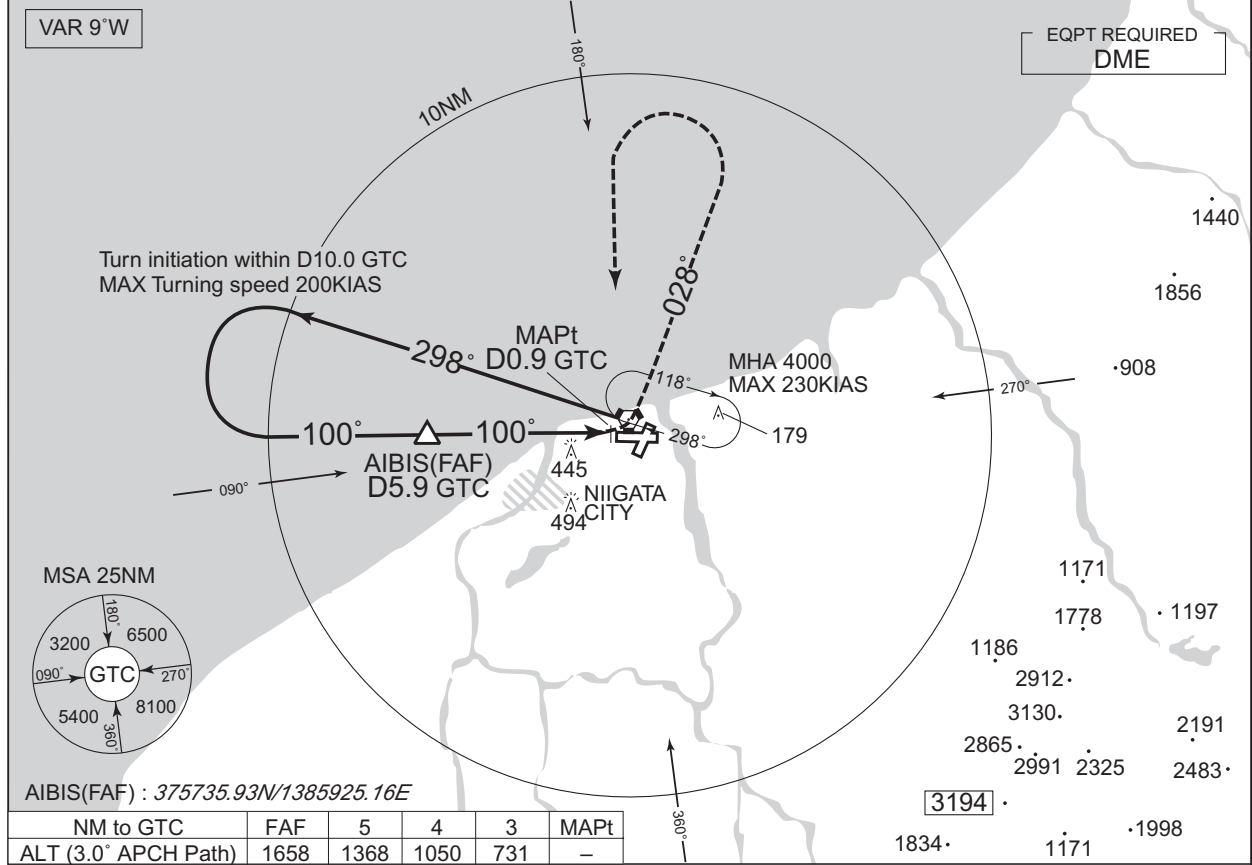

5.9	2.7	0.9	DME to GTC
5.0	1.8	0	NM to THR

MINIMA		THR elev. 27		AD elev. 5	
CAT	MDA(H)	CMV	CIRCLING		
			MDA(H)	VIS	
A	630 (625)	1400	710 (705)	1600	
B		1500			
C		1600	790 (785)	2400	
D		1800			

**INTENTIONALLY LEFT BLANK**

RJSN / NIIGATA

Visual REP

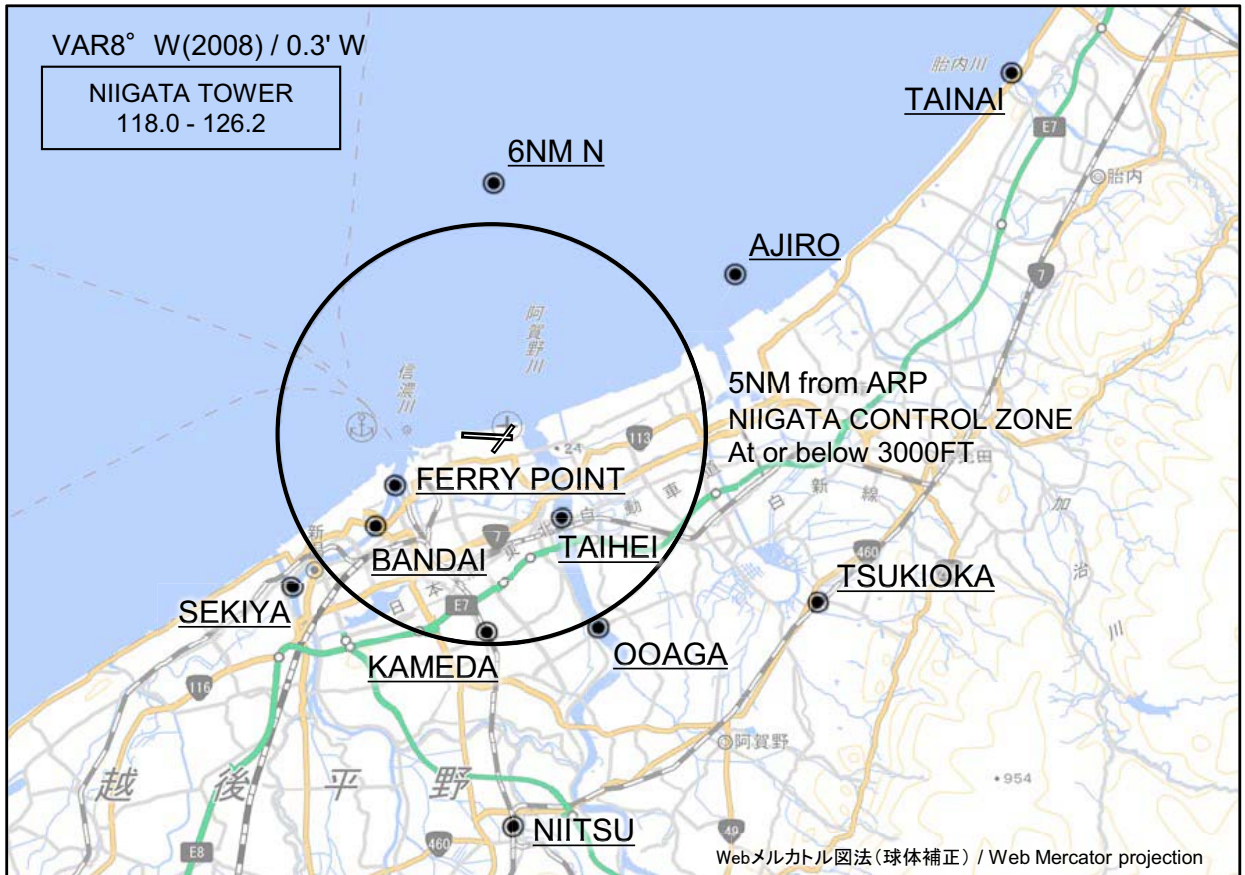

※図中に標高を示す数字がある場合、単位はメートル(m)である。The unit of measurement used to express elevation is meter(m).

CHANGE : Map updated. BRG/DIST from ARP.

Call sign	BRG / DIST from ARP	Remarks
胎内 Tainai	054°T / 14.9NM	胎内川河口 River-mouth
6NM N	360°T / 6.0NM	海上 Over the sea
網代 Ajiro	056°T / 6.9NM	防波堤突端の赤色灯台 Red lighthouse at the tip of breakwater
*フェリーポイント Ferry point	243°T / 2.6NM	万代橋より信濃川下流2kmの地点 (1,500FT以下で通過すること) The point 2km down the Shinano from the Bandai Bridge.(Fly with ALT at or below 1500FT)
*泰平 Taihei	141°T / 2.5NM	橋 Bridge
*万代 Bandai	232°T / 3.5NM	橋 Bridge
関屋 Sekiya	232°T / 6.0NM	分水路への分岐点 Diverging-point for Flood-control channel
月岡 Tsukioka	118°T / 8.6NM	JR駅 Station
大阿賀 Ooaga	152°T / 5.2NM	橋 Bridge
亀田 Kameda	182°T / 4.7NM	JR駅 Station
新津 Niitsu	177°T / 9.4NM	JR駅 Station

\*ヘリコプター Use for helicopter

RJSN / NIIGATA

TFC PATTERN

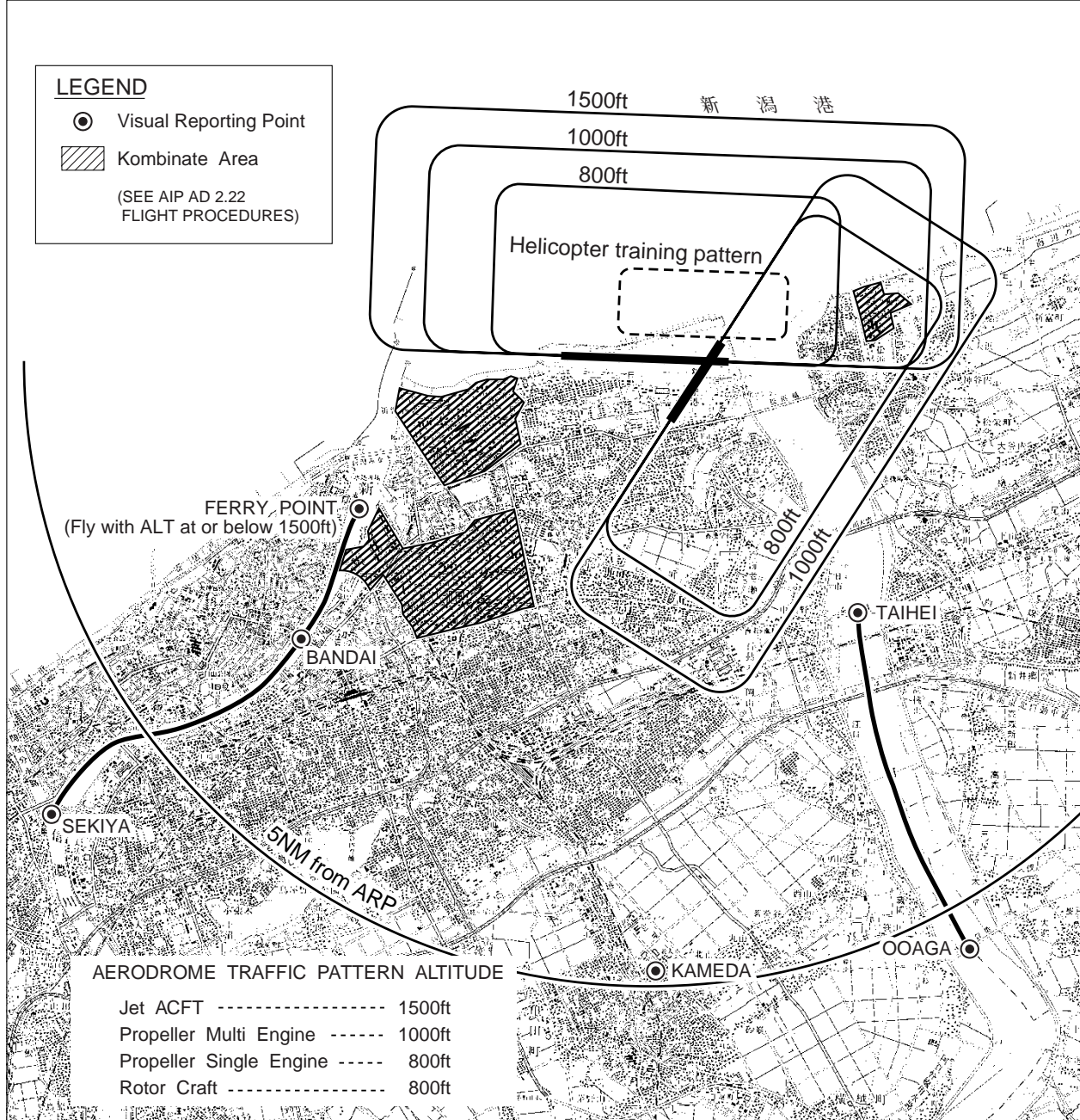

阿賀野ルート：大阿賀～泰平間の阿賀野川に沿う飛行経路（回転翼航空機用）

AGANO ROUTE : The route along Agano river between OOAGA and TAIHEI (Use for Rotor Craft)

信濃ルート：関屋～万代～フェリーポイント間の信濃川に沿う飛行経路（回転翼航空機用）

SHINANO ROUTE : The route along Shinano river between SEKIYA, BANDAI and FERRY POINT  
(Use for Rotor Craft)

※新潟タワーから上記ルートによる飛行の指示があった場合、VFR回転翼航空機は空港周辺における航空機騒音軽減のためVMCを維持できない場合を除き可能な限り当該ルートに沿って飛行することが望ましい。

※In order to reduce aircraft noise in the vicinity of airport, VFR Rotor Craft is expected to follow the above mentioned route when insructed by Niigata tower. (except the case of IMC)

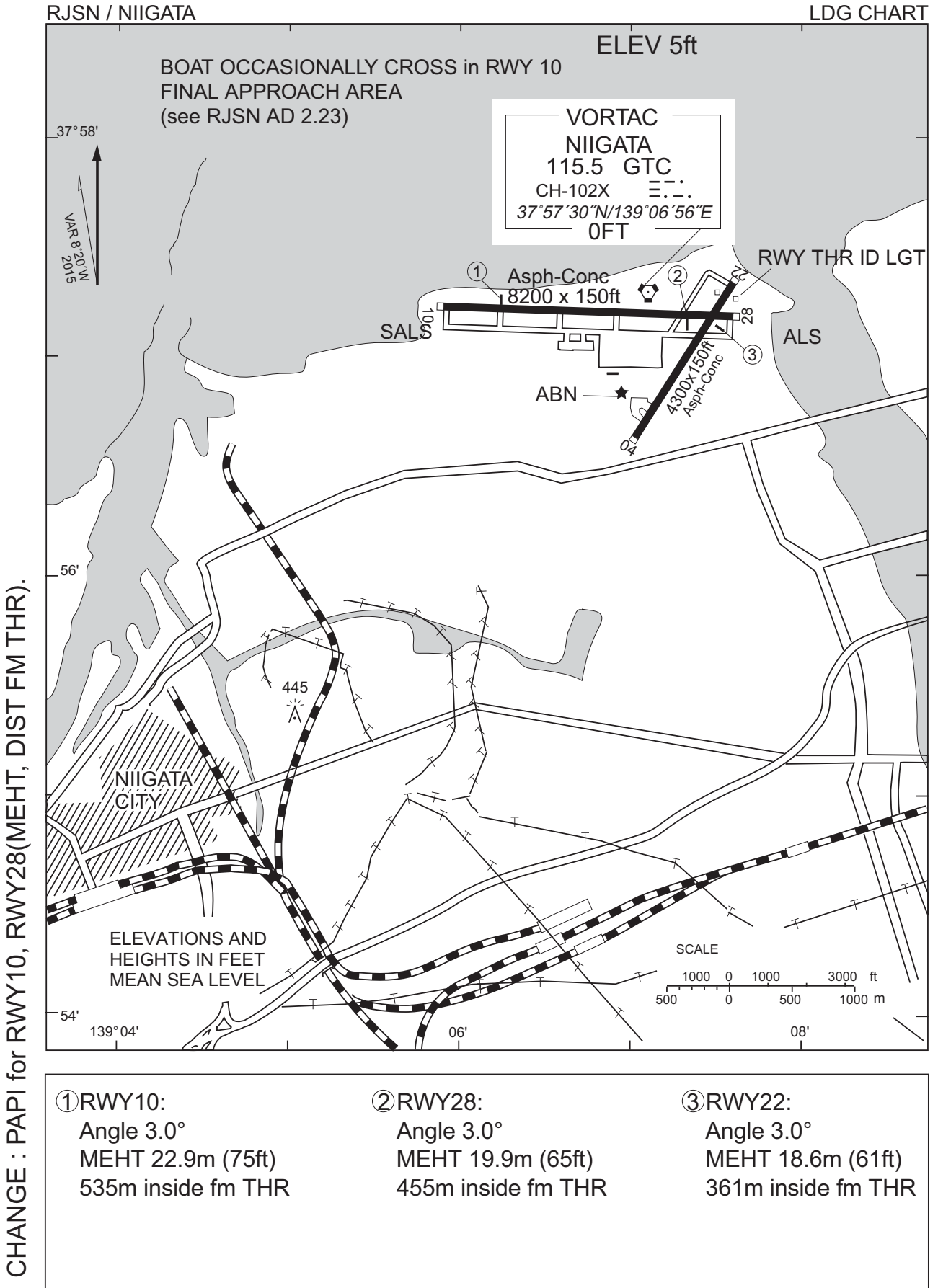

RJSN / NIIGATA

Minimum Vectoring Altitude CHART

