

AD 2 AERODROMES

RJTH AD 2.1 AERODROME LOCATION INDICATOR AND NAME

RJTH - HACHIOJIMA

RJTH AD 2.2 AERODROME GEOGRAPHICAL AND ADMINISTRATIVE DATA

1	ARP coordinates and site at AD	330654N/1394709E 1.0km from RWY08 THR
2	Direction and distance from (city)	1.0km NW from Hachijo town office
3	Elevation/ Reference temperature	301ft / 30°C(2004-2008)
4	Geoid undulation at AD ELEV PSN	144FT
5	MAG VAR/ Annual change	7°W(2024) / 4'W
6	AD Administration, address, telephone, telefax, telex, AFS, e-mail and/or Web-site addresses	Tokyo Municipal Govt. 2839-2, Ookago, Hachijo-machi, Hachijo-jima(Is.), Tokyo. TEL:04996-2-0163 FAX:04996-2-3173
7	Types of traffic permitted(IFR/VFR)	IFR/VFR
8	Remarks	Nil

RJTH AD 2.3 OPERATIONAL HOURS

1	AD Administration	2300 - 0900
2	Customs and immigration	On request Customs: 03-3599-6286 Immigration: 0570-034259 (Department Number 210)
3	Health and sanitation	Quarantine(human): On request(03-3599-1515) Quarantine(animal, plant): Nil
4	AIS Briefing Office	Nil
5	ATS Reporting Office(ARO)	Nil
6	MET Briefing Office	H24 (TOKYO)
7	ATS	2300 - 0900 Remarks: AFIS provided by New Chitose Airport Office.
8	Fuelling	2300 - 0900(On Request)
9	Handling	2300 - 0900
10	Security	2300 - 0900
11	De-icing	Nil
12	Remarks	Nil

RJTH AD 2.4 HANDLING SERVICES AND FACILITIES

1	Cargo-handling facilities	Nil
2	Fuel/ oil types	Fuel : JET A-1
3	Fuelling facilities/ capacity	Fuel truck
4	De-icing facilities	Nil
5	Hangar space for visiting aircraft	Nil
6	Repair facilities for visiting aircraft	Nil
7	Remarks	Nil

RJTH AD 2.5 PASSENGER FACILITIES

1	Hotels	Nil
2	Restaurants	Nil
3	Transportation	Nil
4	Medical facilities	Nil
5	Bank and Post Office	Nil
6	Tourist Office	Nil
7	Remarks	Nil

RJTH AD 2.6 RESCUE AND FIRE FIGHTING SERVICES

1	AD category for fire fighting	CAT 7
2	Rescue equipment	Chemical fire fighting truck x 2
3	Capability for removal of disabled aircraft	Nil
4	Remarks	Nil

RJTH AD 2.7 SEASONAL AVAILABILITY-CLEARING

1	Types of clearing equipment	Not Applicable
2	Clearance priorities	Nil
3	Remarks	Nil

RJTH AD 2.8 APRONS, TAXIWAYS AND CHECK LOCATIONS DATA

1	Apron surface and strength	Surface:Asphalt Concrete, Strength:PCN 41/R/B/X/T
2	Taxiway width, surface and strength	Width : 23m Surface : Asphalt Concrete, Strength:PCN 42/F/A/X/T
3	ACL and elevation	Not available
4	VOR checkpoints	Not available
5	INS checkpoints	Spot NR 1 330656.14N , 1394657.15E 2 330657.40N , 1394658.03E 3 330657.86N , 1394659.68E
6	Remarks	Nil

RJTH AD 2.9 SURFACE MOVEMENT GUIDANCE AND CONTROL SYSTEM AND MARKINGS

1	Use of aircraft stand ID signs, TWY guide lines and Visual docking/ parking guidance system of aircraft stands	Nil
2	RWY and TWY markings and LGT	RWY:08/26 (Marking):RWY designation, RWY CL, RWY THR, RWY middle point, Aiming point, TDZ, RWY side stripe (LGT): RCLL, REDL, RTHL, RENL TWY: (Marking):TWY CL, RWY HLDG PSN, TWY side stripe (LGT):TWY edge LGT, TWY CL LGT
3	Stop bars	Nil
4	Remarks	(Marking):Overrun area (LGT):Apron flood LGT

RJTH AD 2.10 AERODROME OBSTACLES

RWY/Area affected	Obstacle type	Coordinates	Elevation	Markings/ LGT	Remarks
Nil					

RJTH AD 2.11 METEOROLOGICAL INFORMATION PROVIDED

1	Associated MET Office	TOKYO
2	Hours of service MET Office outside hours	H24 (TOKYO)
3	Office responsible for TAF preparation Periods of validity	Nil
4	Trend forecast Interval of issuance	Nil
5	Briefing/ consultation provided	Briefing is available upon inquiry at TOKYO
6	Flight documentation Language(s) used	C En
7	Charts and other information available for briefing or consultation	S ₆ , U ₈₅ , U ₇ , U ₅ , U ₃ , U ₂₅ , U ₂ /T _r , P _S , P ₅ , P ₃ , P ₂₅ , P _{SWE} , P _{SWF} , P _{SWG} , P _{SWI} , P _{SWM} , P _{SW} (domestic), E, C, W _E , W _F , W _G , W _I , W, N
8	Supplementary equipment available for providing information	Nil
9	ATS units provided with information	RADIO
10	Additional information(limitation of service, etc.)	Nil

RJTH AD 2.12 RUNWAY PHYSICAL CHARACTERISTICS

Designations RWY NR	TRUE BRG	Dimensions of RWY(M)	Strength(PCN) and surface of RWY	THR coordinates THR geoid undulation	THR elevation and highest elevation of TDZ of precision APP RWY
1	2	3	4	5	6
08	069.56°	2000x45	PCN 42/F/A/X/T Asphalt Concrete	330643.03N 1394633.07E	THR ELEV : 282ft
26	249.56°	2000x45	PCN 42/F/A/X/T Asphalt Concrete	330705.72N 1394745.36E	THR ELEV : 284ft
Slope of RWY		Strip Dimensions(M)	RESA(Overrun) Dimensions(M)	Remarks	
7		10	11	14	
See Below Figure		2120x150 2120x150	40x150 40x150	RWY Grooving: 2000x30m	

Slope of RWY

Distance (m)	Elevation (ft)	Slope (%)
0	282	0.66%
70	284	0.76%
280	289	0.63%
680	297	0.34%
830	299	0.26%
1180	302	0.59%
1630	293	0.79%
1870	287	0.71%
2000	284	

RJTH AD 2.13 DECLARED DISTANCES

RWY Designator	TORA (m)	TODA (m)	ASDA (m)	LDA (m)	Remarks
1	2	3	4	5	6
08	2000	2000	2000	2000	Nil
26	2000	2000	2000	2000	Nil

RJTH AD 2.14 APPROACH AND RUNWAY LIGHTING

RWY Designator	APCH LGT type LEN INTST	RTHL Color WBAR	PAPI (VASIS) Angle DIST FM THR MEHT	RTZL LEN	RCLL LEN Spacing Color INTST	REDL LEN Spacing Color INTST	RENL Color WBAR	STWL LEN Color
1	2	3	4	5	6	7	8	9
08	Nil (*1)	Green Nil	PAPI 3.0°/LEFT 324.3m 61ft		2000m 30m Coded color (White/Red) LIH	2000m 60m Coded color (White/Yellow) LIH	Red	Nil(*3)
26	SALS 420m (*2) LIH	Green Nil	PAPI 3.0°/LEFT 322.6m 61ft		2000m 30m Coded color (White/Red) LIH	2000m 60m Coded color (White/Yellow) LIH	Red	Nil(*3)
Remarks								
10								
APCH Guidance LGT for RWY 08(LEN:2013m)(*1) SALS with APCH Guidance LGT for RWY 26(LEN:1579m)(*2) Overrun area edge LGT(LEN:30m Color:Red)(*3) RWY THR ID LGT for RWY08 THR(Color:White)								

RJTH AD 2.15 OTHER LIGHTING, SECONDARY POWER SUPPLY

1	ABN/IBN location, characteristics and hours of operation	ABN: 330703N/1394703E, White/Green EV4.3sec, HO
2	LDI location and LGT Anemometer location and LGT	LDI:Nil Anemometer: RWY08:250m FM RWY08 THR, LGTD Mid:300m FM ARP, LGTD RWY26:150m FM RWY26 THR, LGTD
3	TWY edge and center line lighting	TWY edge and center line lights installed, see AD2.9
4	Secondary power supply / switch-over time	Within 15 sec: SALS, RTHL, PAPI, RCLL, REDL, RENL, Overrun area edge LGT, RWY THR ID LGT for RWY08 THR, ABN, TWY edge LGT, TWY CL LGT, WDI LGT, Apron flood LGT
5	Remarks	WDI LGT

RJTH AD 2.16 HELICOPTER LANDING AREA

Nil

RJTH AD 2.17 ATS AIRSPACE

Designation and lateral limits		Vertical limits (ft)	Airspace classification	ATS unit call sign Language	Remarks
1		2	3	4	6
Hachijojima Information zone	Area within a radius of 5nm(9km) of HACHIJOJIMA ARP	3000 or below	E	Hachijo Radio En	

RJTH AD 2.18 ATS COMMUNICATION FACILITIES

Service designation	Call sign	Frequency	Hours of operation	Remarks
1	2	3	4	5
AFIS	Hachijo Radio	118.7MHz	2300 - 0900	Operated by New Chitose Airport Office

RJTH AD 2.19 RADIO NAVIGATION AND LANDING AIDS

Type of aid (VOR declination)	ID	Frequency	Hours of operation	Position of transmitting antenna coordinates	Elevation of DME transmitting antenna	Remarks
1	2	3	4	5	6	7
VOR (7°W/2022)	HCE	116.65MHz	H24	330651.66N/ 1394718.54E		VOR/DME Unusable: 090°-100° beyond 20NM below 5000ft. 100°-200° beyond 5NM below 5000ft. 280°-300° beyond 20NM below 5000ft. 300°-360° beyond 3NM below 5000ft.
DME	HCE	1074MHz (CH-113Y)	H24	330651.66N/ 1394718.54E	339ft	
LOC 26	IHC	110.1MHz	2300 - 0900	330647.86N/ 1394700.58E		LOC: 720m (2362ft) inside FM RWY 08 THR, 110m (361ft) S of RCL. OFFSET 3.0°, BRG (MAG) 253.51° Unusable: beyond 30° North side and 20° South side of LOC course.
LOC-DME 26	IHC	999MHz	2300 - 0900	330647.19N/ 1394700.54E		LOC-DME: 710m (2329ft) inside FM RWY 08 THR, 128m (420ft) S of RCL.
MSAS		1575.42MHz	H24			Transmitting antennas are satellite based.

HACHIJOJIMA AP

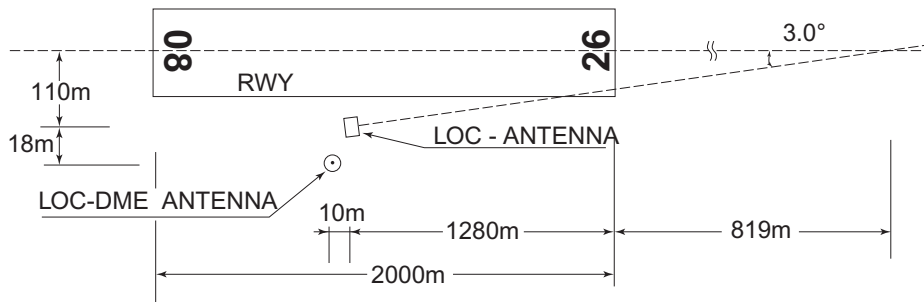

REMARKS : 1. LOC offset Angle 3.0°
2. LOC beam BRG(MAG) 253.51°

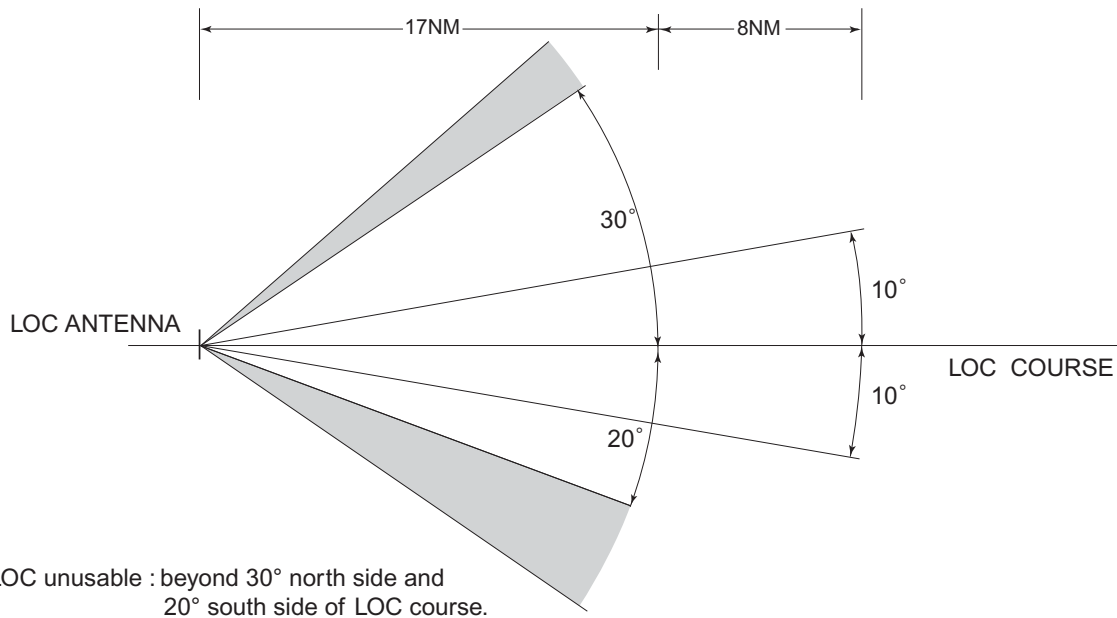

RJTH AD 2.20 LOCAL TRAFFIC REGULATIONS

1. Airport regulations

Nil

2. Taxiing to and from stands

Nil

3. Parking area for small aircraft(General aviation)

Nil

4. Parking area for helicopters

Nil

5. Apron - taxiing during winter conditions

Nil

6. Taxiing - limitations

Nil

7. School and training flights - technical test flights - use of runways

In principle, no flight training is permitted.
To apply for an exception, the administrator's prior permission is required.

8. Helicopter traffic - limitation

Nil

9. Removal of disabled aircraft from runways

Nil

RJTH AD 2.21 NOISE ABATEMENT PROCEDURES

Nil

RJTH AD 2.22 FLIGHT PROCEDURES

TAKE OFF MINIMA

	RWY	ACFT CAT	REDL & RCLL		REDL or RCLL or RCL Marking		NIL (DAYTIME ONLY)	
			RVR	VIS	RVR	VIS	RVR	VIS
Multi-Engine ACFT with TKOF ALTN AP FILED	08	A,B,C,D	-	400m	-	400m	-	500m
	26							
OTHER	08	A,B,C,D	AVBL LDG MINIMA					
	26							

RJTH AD 2.23 ADDITIONAL INFORMATION

Nil

RJTH AD 2.24 CHARTS RELATED TO AN AERODROME

<p>Aerodrome/Heliport Chart Standard Departure Chart-Instrument (HACHIJO REVERSAL) Standard Departure Chart-Instrument (TOPIT-RNAV) Standard Arrival Chart-Instrument Instrument Approach Chart (LOC Z RWY26) Instrument Approach Chart (LOC Y RWY26) Instrument Approach Chart (VOR A For RWY26)* Instrument Approach Chart (VOR B For RWY08)* Instrument Approach Chart (RNP Z RWY08(AR)) Instrument Approach Chart (RNP Y RWY08(AR)) Instrument Approach Chart (RNP Z RWY26(AR)) Instrument Approach Chart (RNP Y RWY26(AR)) Other Chart (Visual REP) Other Chart (LDG Chart) Other Chart (MVA Chart)</p>
--

*: Designed in accordance with provisional standards for FLIGHT PROCEDURE DESIGN.

RJTH / HACHIOJIMA

AD CHART

CHANGE : VAR.

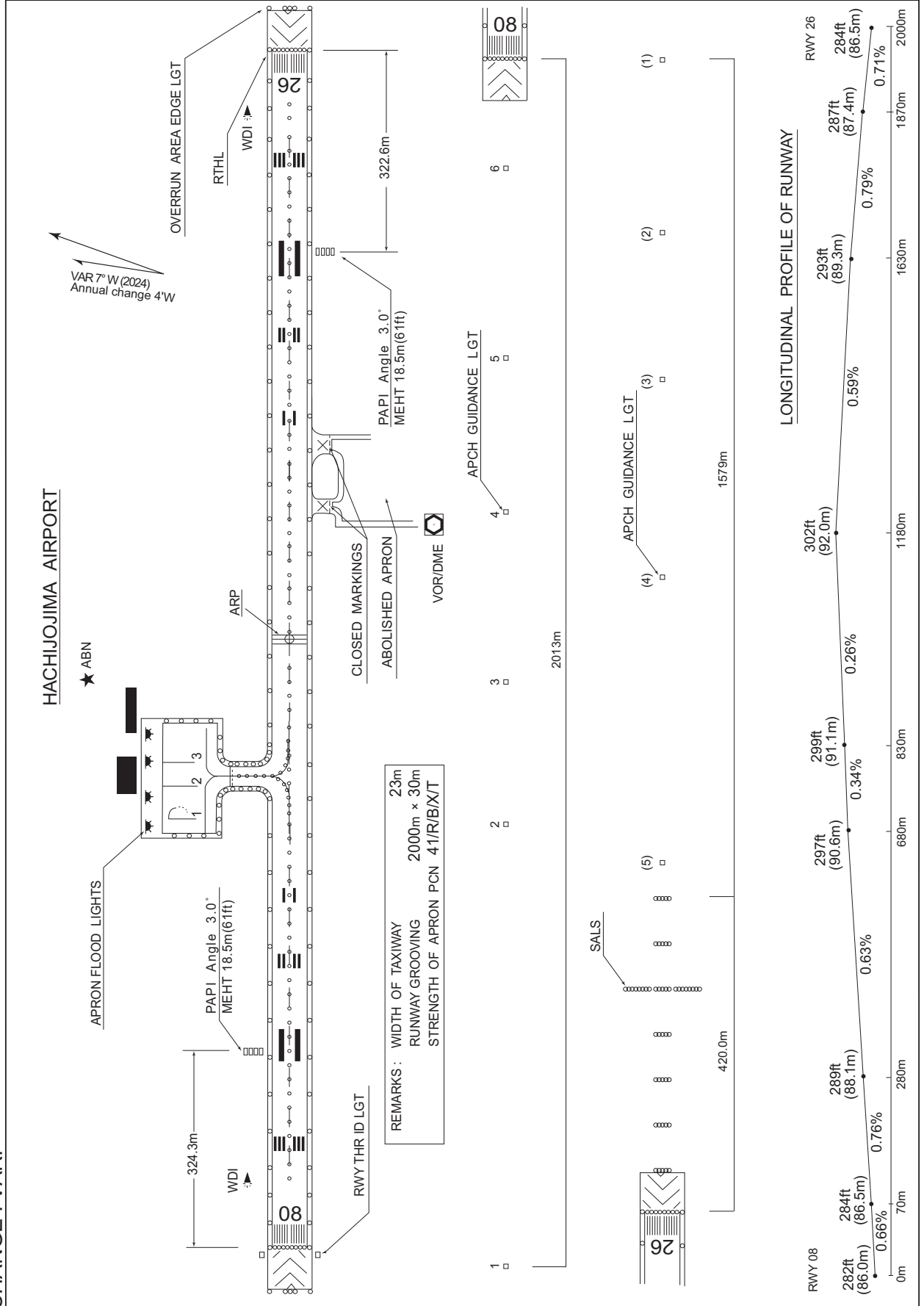

INTENTIONALLY LEFT BLANK

STANDARD DEPARTURE CHART-INSTRUMENT

RJTH / HACHIOJIMA

SID

HACHIOJO REVERSAL SIX DEPARTURE

RWY08 : Climb RWY HDG to HCE 3.0DME, turn left HDG 027° to intercept and proceed via HCE R057 to 9.0DME, turn right, direct to HCE VOR/DME.

Cross HCE R057/9.0DME at or above 3000FT,
cross HCE VOR/DME at or above 5000FT.

RWY26 : Climb RWY HDG to HCE 3.0DME, turn left HDG 211° to intercept and proceed via HCE R241 to 9.0DME, turn left, direct to HCE VOR/DME.

Cross HCE R241/9.0DME at or above 3000FT,
cross HCE VOR/DME at or above 5000FT.

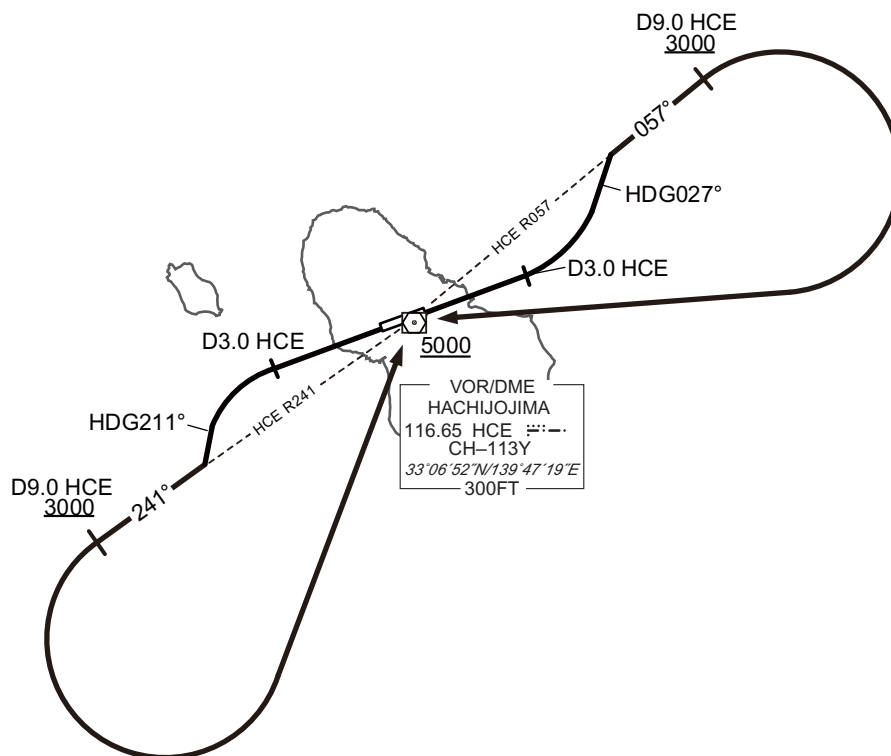

CHANGE : PROC renamed. PROC course.

STANDARD DEPARTURE CHART-INSTRUMENT

RJTH / HACHIJOJIMA

RNAV SID

TOPIT ONE DEPARTURE

RNP1

Note GNSS required.

VAR 7° W

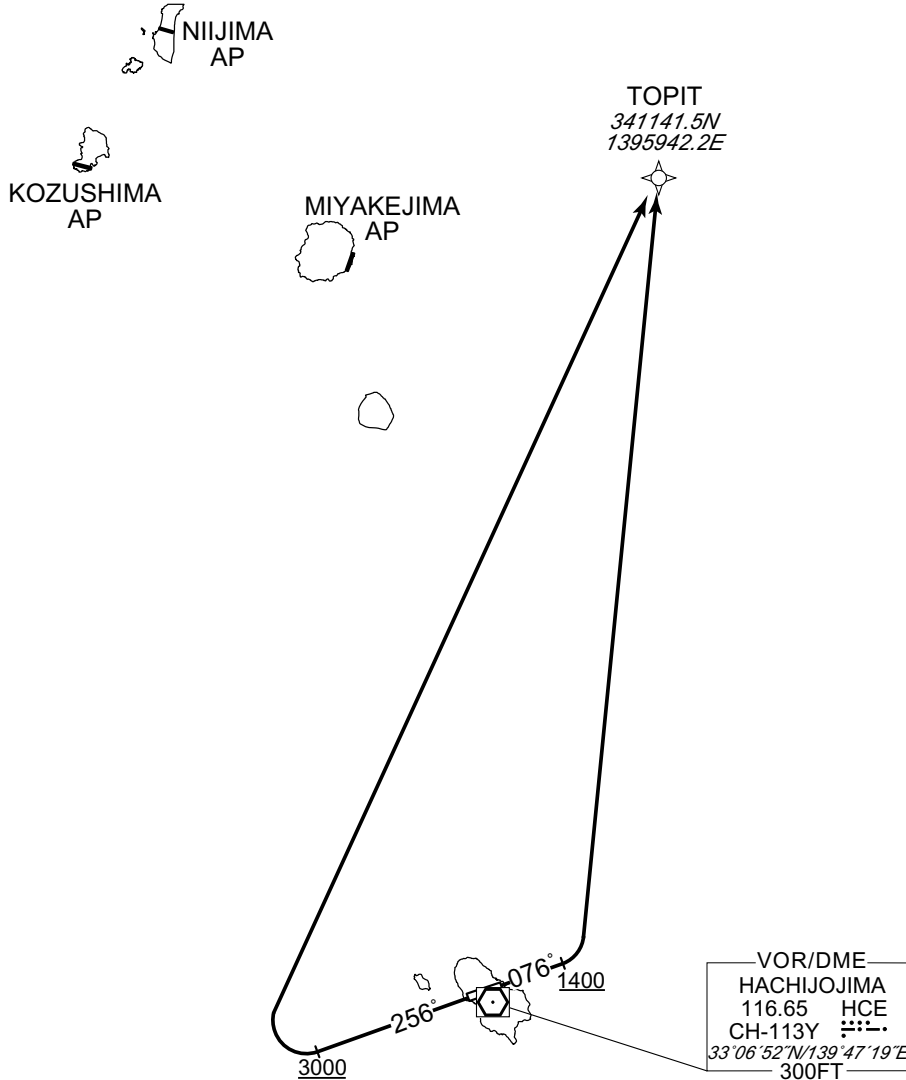

RWY08 : Climb on HDG 076° at or above 1400FT, turn left direct to TOPIT.
 RWY26 : Climb on HDG 256° at or above 3000FT, turn right direct to TOPIT.

RWY08

Serial Number	Path Descriptor	Waypoint Identifier	Fly Over	Course °M(°T)	Magnetic Variation	Distance (NM)	Turn Direction	Altitude (FT)	Speed (KIAS)	Vertical Angle	Navigation Specification
001	VA	-	-	076 (069.5)	-6.7	-	-	+1400	-	-	RNP1
002	DF	TOPIT	-	-	-6.7	-	L	-	-	-	RNP1

RWY26

Serial Number	Path Descriptor	Waypoint Identifier	Fly Over	Course °M(°T)	Magnetic Variation	Distance (NM)	Turn Direction	Altitude (FT)	Speed (KIAS)	Vertical Angle	Navigation Specification
001	VA	-	-	256 (249.5)	-6.7	-	-	+3000	-	-	RNP1
002	DF	TOPIT	-	-	-6.7	-	R	-	-	-	RNP1

CHANGE : Navigation Specification(Basic RNP1 → RNP1).

STANDARD ARRIVAL CHART-INSTRUMENT

RJTH/HACHIOJIMA RNAV STAR RWY26

SANGO ARRIVAL

RNP1

Note GNSS required.

VAR7°W

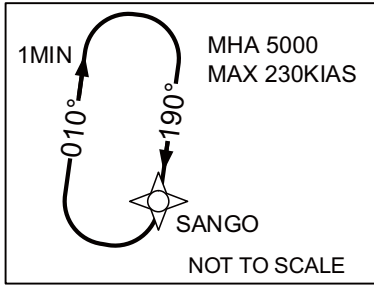

SANGO
332250.4N
1394814.0E
5000



9.5
134°



TH671
331705.1N
1395719.0E

6.0
164°

SHELL
331133.7N
1400008.6E
2000

2000

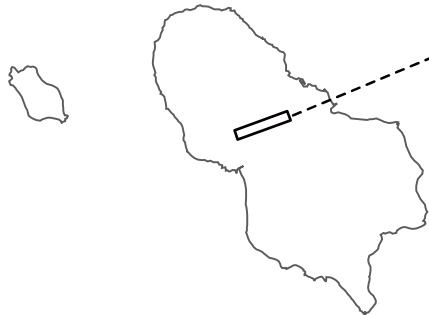

CHANGE : Navigation Specification(Basic RNP1 → RNP1).

From SANGO at or above 5000FT, to TH671, to SHELL at or above 2000FT.

Serial Number	Path Descriptor	Waypoint Identifier	Fly Over	Course °M(°T)	Magnetic Variation	Distance (NM)	Turn Direction	Altitude (FT)	Speed (KIAS)	Vertical Angle	Navigation Specification
001	IF	SANGO	-	-	-6.9	-	-	+5000	-	-	RNP1
002	TF	TH671	-	134 (127.1)	-6.9	9.5	-	-	-	-	RNP1
003	TF	SHELL	-	164 (156.8)	-6.9	6.0	-	+2000	-	-	RNP1

Path	Waypoint Identifier	Inbound Course °M(°T)	Magnetic Variation	Outbound Time (MIN)	Turn Direction	Minimum Altitude (FT)	Maximum Altitude (FT)	Speed (KIAS)	Navigation Specification
Hold	SANGO	190 (182.8)	-6.9	1.0(-14000)	R	5000	FL140	-230(-14000)	RNP1

INTENTIONALLY LEFT BLANK

INSTRUMENT APPROACH CHART

RJTH / HACHIOJIMA

LOC Z RWY26

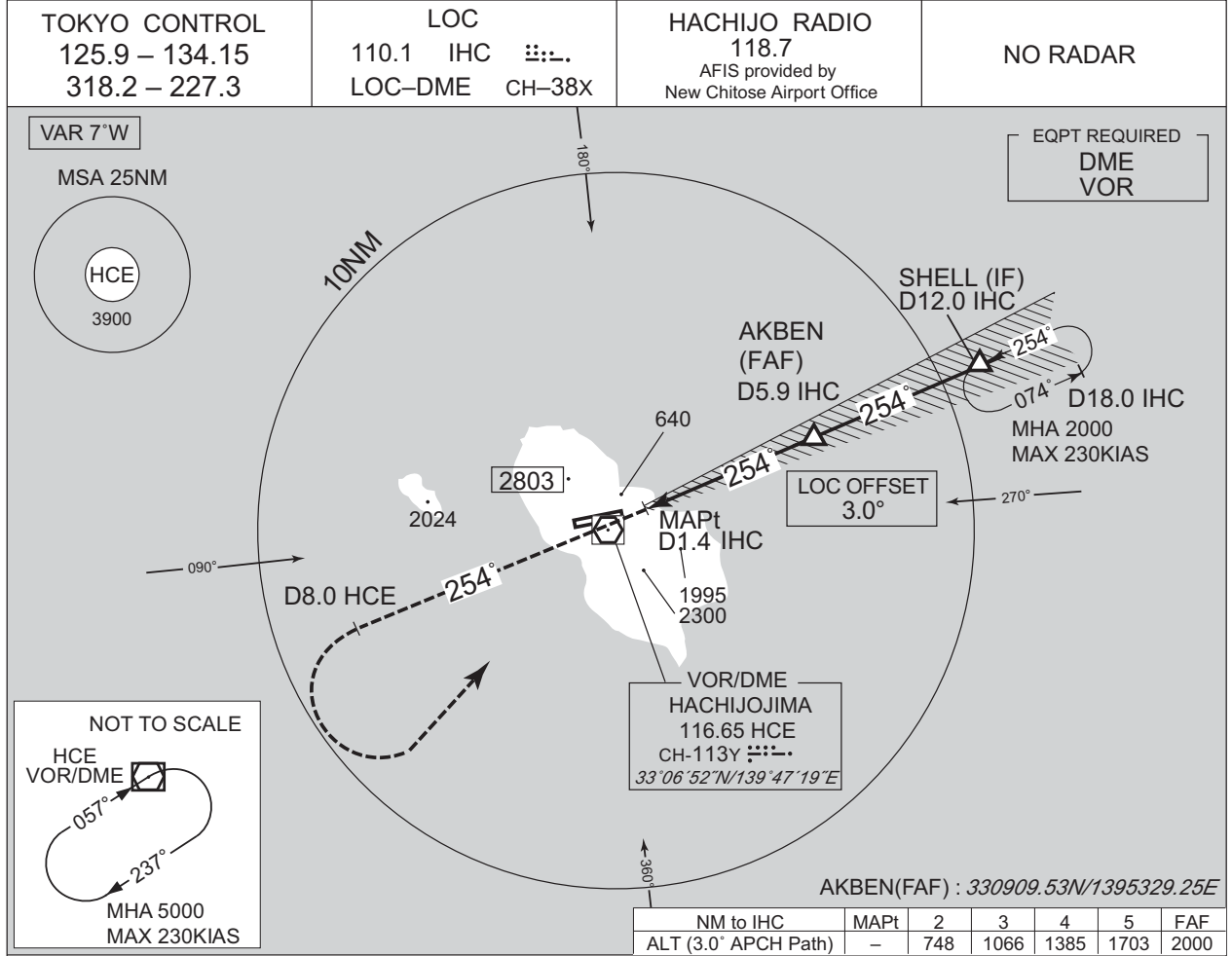

CHANGE : PROC course. HLDG course for SHELL. ALT(3.0°APCH path).

MISSED APPROACH
Climb via HCE R254 to HCE 8.0DME, turn left, direct to HCE VOR/DME and hold at 5000FT.
Contact HACHIOJO RADIO.

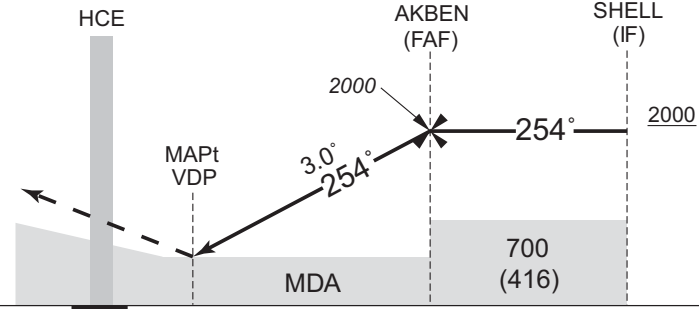

Timing not authorized for defining the MAPt.

	DME to IHC	0.7	1.4	5.9	12.0
	NM to THR	0	0.7	5.2	11.3

MINIMA		THR elev. 284	AD elev. 301	
CAT	CIRCLING			
	MDA(H)	CMV	MDA(H)	VIS
A	550 (266)	1000	-	-
B		1100		
C		1200		
D		1400		

Circling NOT authorized.

INSTRUMENT APPROACH CHART

RJTH / HACHIJOJIMA

LOC Y RWY26

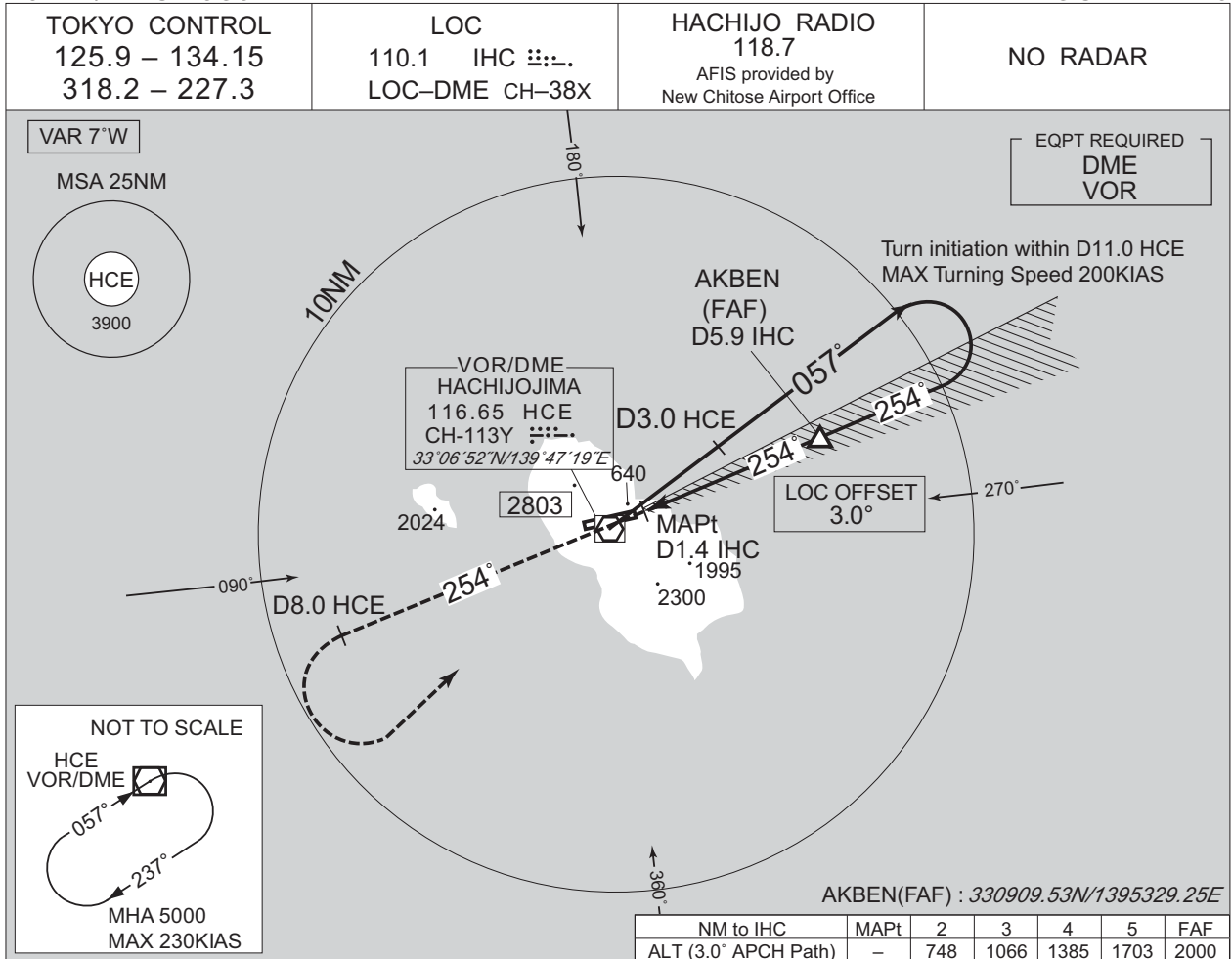

MISSED APPROACH

Climb via HCE R254 to HCE 8.0DME, turn left, direct to HCE VOR/DME and hold at 5000FT. Contact HACHIJO RADIO.

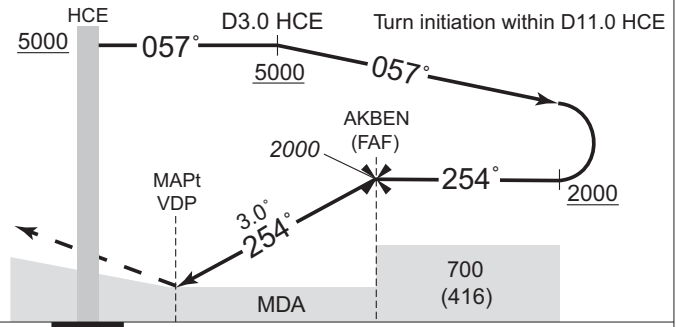

Timing not authorized for defining the MAPt.

DME to IHC	0.7 1.4	5.9
NM to THR	0 0.7	5.2

	MINIMA	THR elev. 284	AD elev. 301	
CAT	CIRCLING			
	MDA(H)	CMV	MDA(H)	VIS
A	550 (266)	1000	-	-
B		1100		
C		1200		
D		1400		

Circling NOT authorized.

CHANGE : PROC course. ALT(3.0°APCH path).

INSTRUMENT APPROACH CHART

RJTH / HACHIOJIMA

VOR A (For RWY 26)

TOKYO CONTROL 125.9 – 134.15 318.2 – 227.3	HACHIOJIMA VOR/DME 116.65 HCE CH-113Y 33°06'52"N/139°47'19"E	HACHIOJIO RADIO 118.7 AFIS provided by New Chitose Airport Office	NO RADAR
--	---	--	----------

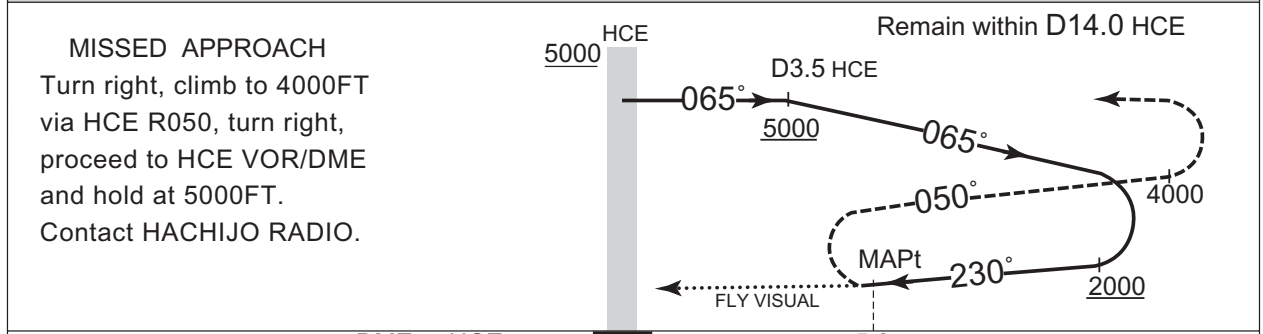
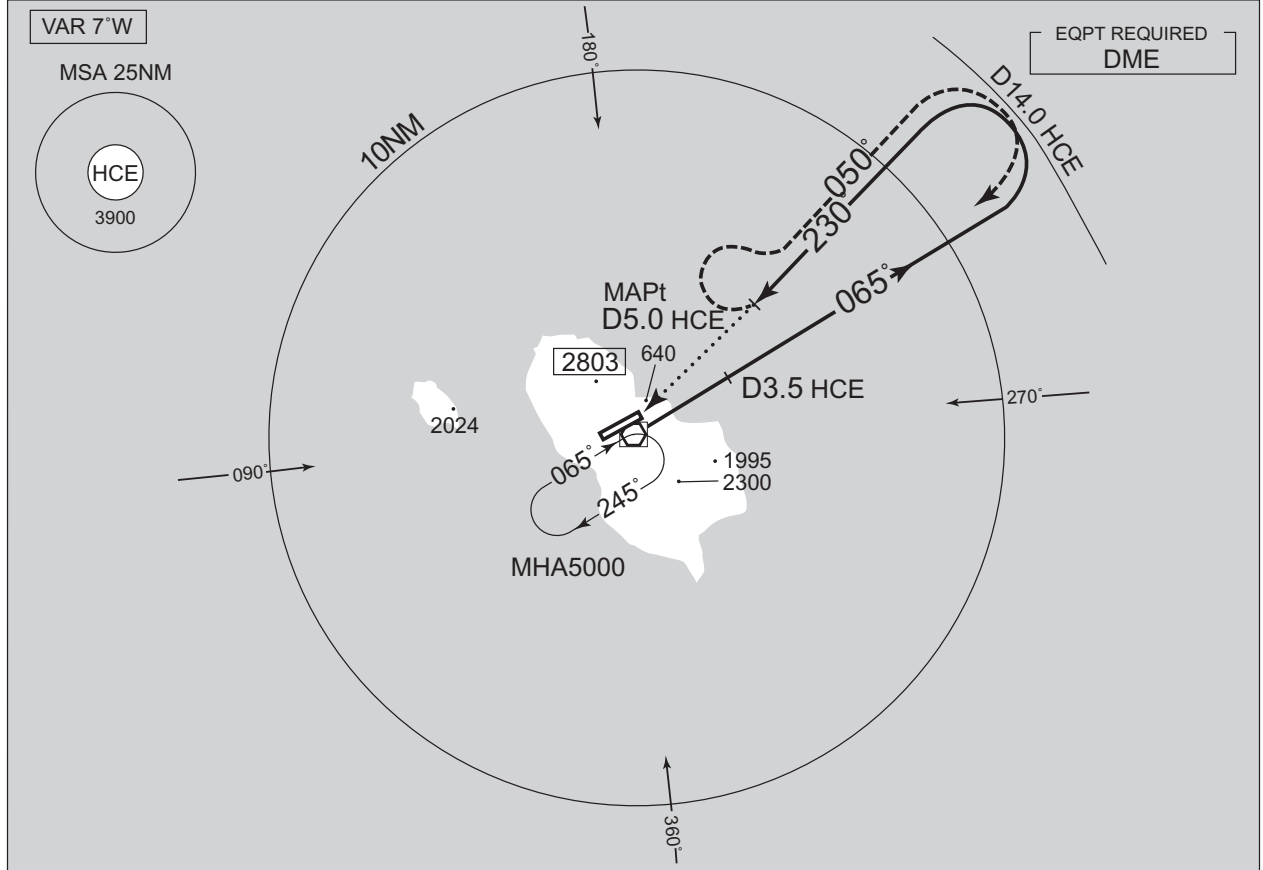

DME to HCE	5.0
NM to THR	4.7

MINIMA		THR elev. 284		AD elev. 301	
CAT	MDA(H)	Facilities			
		Full	Intermediate	Basic	Nil
		VIS		VIS	
A	800 (516)	-	4800		
B					
C					
D					

CHANGE: PROC renamed.

MINIMA APPLICATION CRITERIA in AD1.1.6.10.1.4 are not applicable.

INSTRUMENT APPROACH CHART

RJTH / HACHIJOJIMA

VOR B (For RWY 08)

TOKYO CONTROL 125.9 – 134.15 318.2 – 227.3	HACHIJOJIMA VOR/DME 116.65 HCE CH-113Y 33°06'52"N/139°47'19"E	HACHIJO RADIO 118.7 AFIS provided by New Chitose Airport Office	NO RADAR
--	--	--	----------

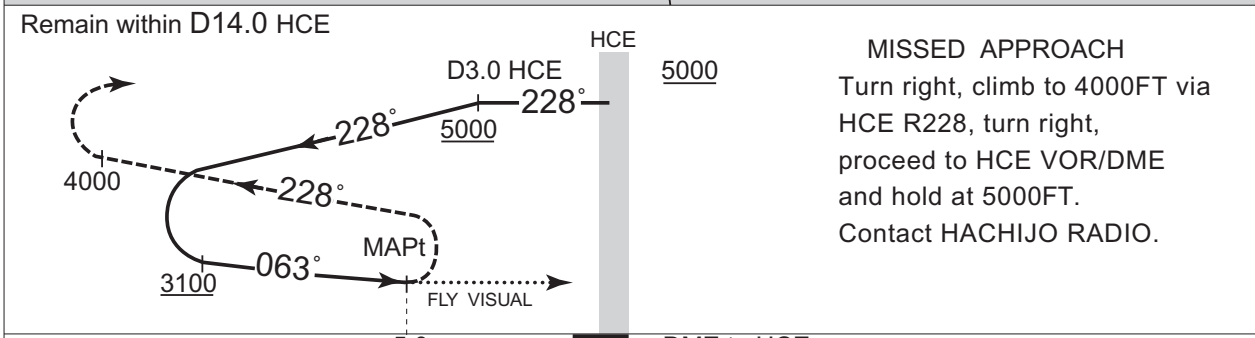
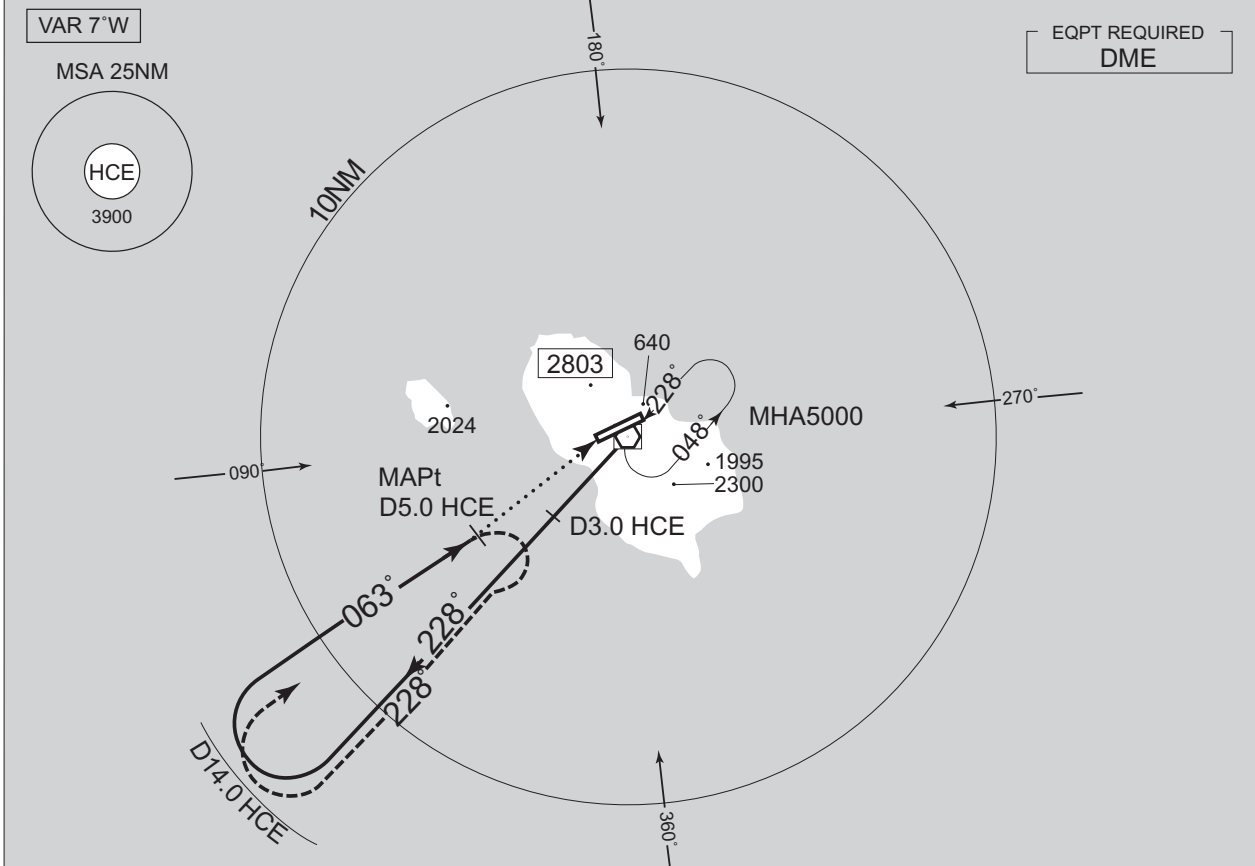

5.0 DME to HCE
4.3 NM to THR

MINIMA		THR elev. 282		AD elev. 301	
CAT	MDA(H)	Facilities			
		Full	Intermediate	Basic	Nil
		VIS			VIS
A	800 (518)				4800
B		-			
C					
D					

MINIMA APPLICATION CRITERIA in AD1.1.6.10.1.4 are not applicable.

CHANGE: PROC renamed.

INSTRUMENT APPROACH CHART

RJTH / HACHIOJIMA

RNP Z RWY08(AR)

TOKYO CONTROL 125.9 - 134.15 318.2 - 227.3	RNP AR RF required.	HACHIOJ RADIO 118.7 AFIS provided by New Chitose Airport Office	NO RADAR
--	------------------------	--	----------

For uncompensated Baro-VNAV systems, procedure not authorized below 0°C / above 45°C

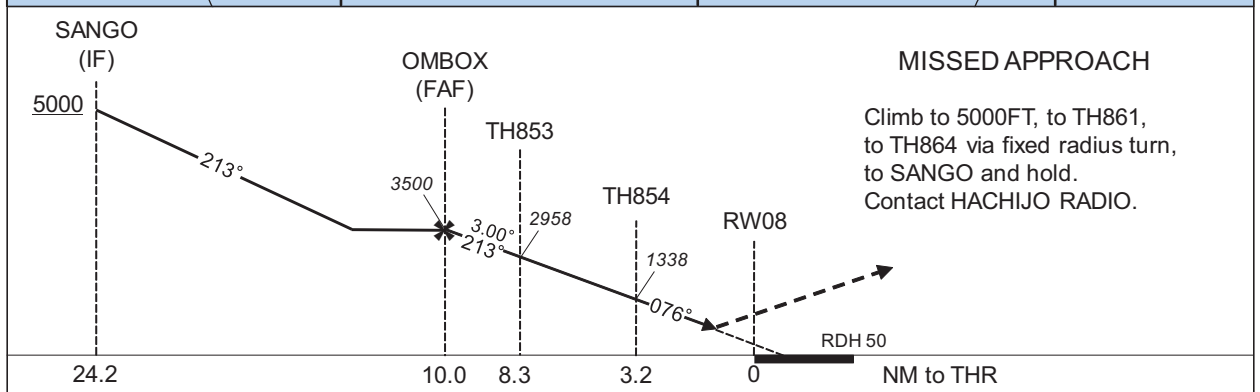
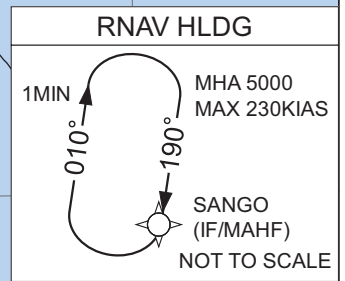
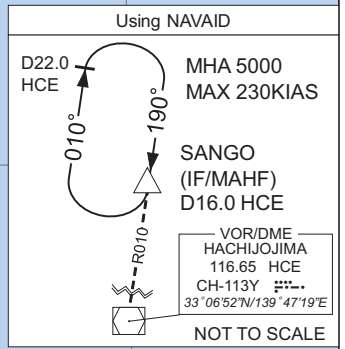
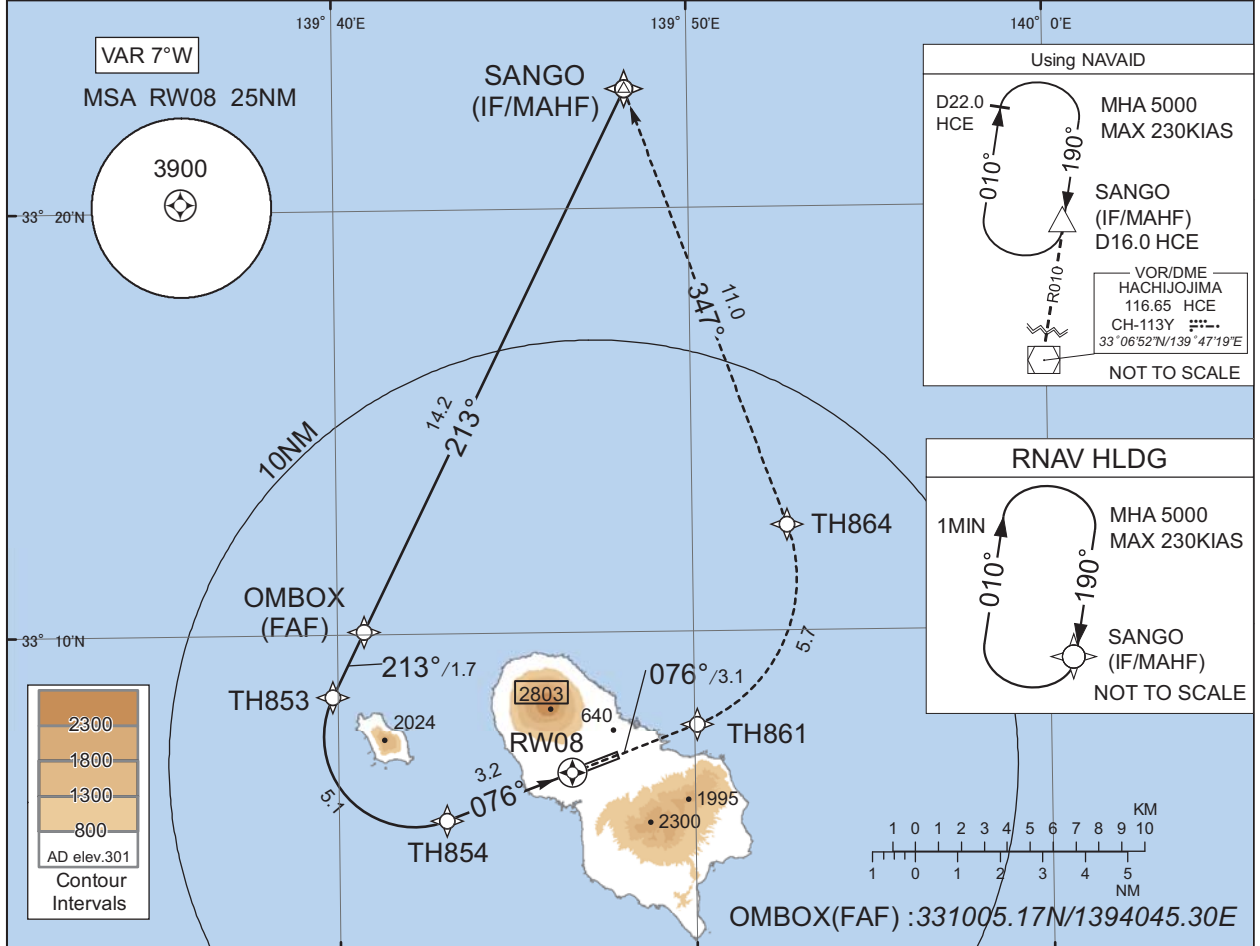

Missed APCH climb gradient MNM 5.0%

CAT	THR elev. 282		AD elev. 301	
	RNP 0.10	RNP 0.30	RNP 0.10	RNP 0.30
	DA(H)	CMV	DA(H)	CMV
A	-	-	-	-
B	-	-	-	-
C	608(326)	1800	823(541)	2000
D	-	-	-	-

MINIMA with Missed APCH climb gradient of 2.5% are not established.

Authorization Required

CHANGE : New PROC.

INSTRUMENT APPROACH CHART

RJTH / HACHIJOJIMA

RNP Z RWY08(AR)

Coding Table

Serial Number	Path Descriptor	Waypoint Identifier	Fly Over	Course °M(°T)	Magnetic Variation	Distance (NM)	Turn Direction	Altitude (FT)	Speed (KIAS)	VPA/ RDH (°/FT)	RNP Value
001	IF	SANGO	-	-	-7.0	-	-	+5000	-	-	-
002	TF	OMBOX	-	213 (206.1)	-7.0	14.2	-	3500	-	-	1.0
003	TF	TH853	-	213 (206.1)	-7.0	1.7	-	2958	-	-3.00	0.10 0.30
004	RF Center: THRF3 r=2.13NM	TH854	-	-	-7.0	5.1	L	1338	-	-3.00	0.10 0.30
005	TF	RW08	Y	076 (069.4)	-7.0	3.2	-	332	-	-3.00/50	0.10 0.30
006	TF	TH861	-	076 (069.5)	-7.0	3.1	-	-	-	-	0.10 0.30
007	RF Center: THRF4 r=3.67NM	TH864	-	-	-7.0	5.7	L	-	-	-	1.0
008	TF	SANGO	-	347 (340.3)	-7.0	11.0	-	5000	-	-	1.0

Path	Waypoint Identifier	Inbound Course °M(°T)	Magnetic Variation	Outbound Time (MIN)	Turn Direction	Minimum Altitude (FT)	Maximum Altitude (FT)	Speed (KIAS)	RNP Value
Hold	SANGO	190 (182.8)	-6.9	1.0 (-14000)	R	5000	FL140	-230 (-14000)	1.0

Waypoint Coordinates

Waypoint Identifier	Coordinates	RF Arc Center Identifier	Coordinates
SANGO	332250.44N / 1394814.02E	THRF3	330736.61N / 1394208.22E
OMBOX	331005.17N / 1394045.30E	THRF4	331116.16N / 1394832.59E
TH853	330833.19N / 1393951.52E		
TH854	330536.55N / 1394301.55E		
RW08	330643.03N / 1394633.07E		
TH861	330749.27N / 1395004.24E		
TH864	331230.95N / 1395239.67E		

CHANGE : New PROC.

INSTRUMENT APPROACH CHART

RJTH / HACHIOJIMA

RNP Y RWY08(AR)

TOKYO CONTROL 125.9 - 134.15 318.2 - 227.3	RNP AR RF required.	HACHIOJO RADIO 118.7 AFIS provided by New Chitose Airport Office	NO RADAR
--	------------------------	---	----------

For uncompensated Baro-VNAV systems, procedure not authorized below 0°C / above 45°C

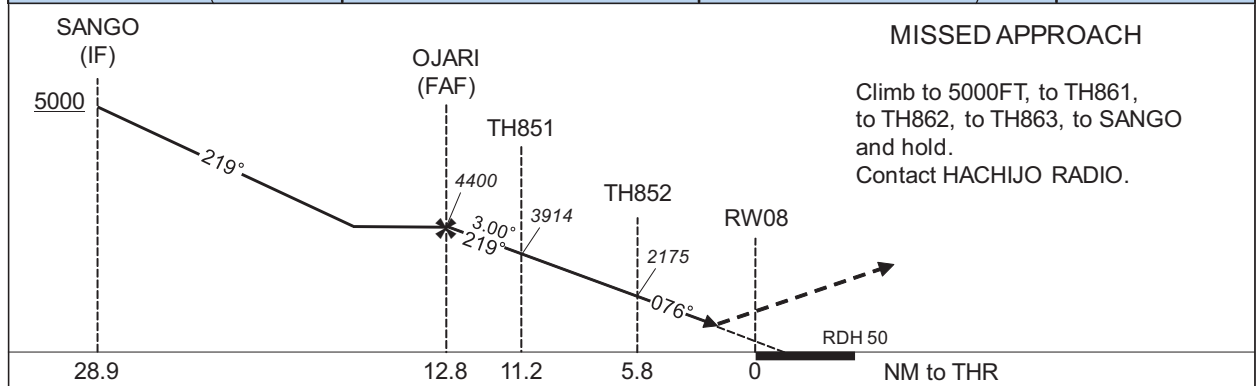
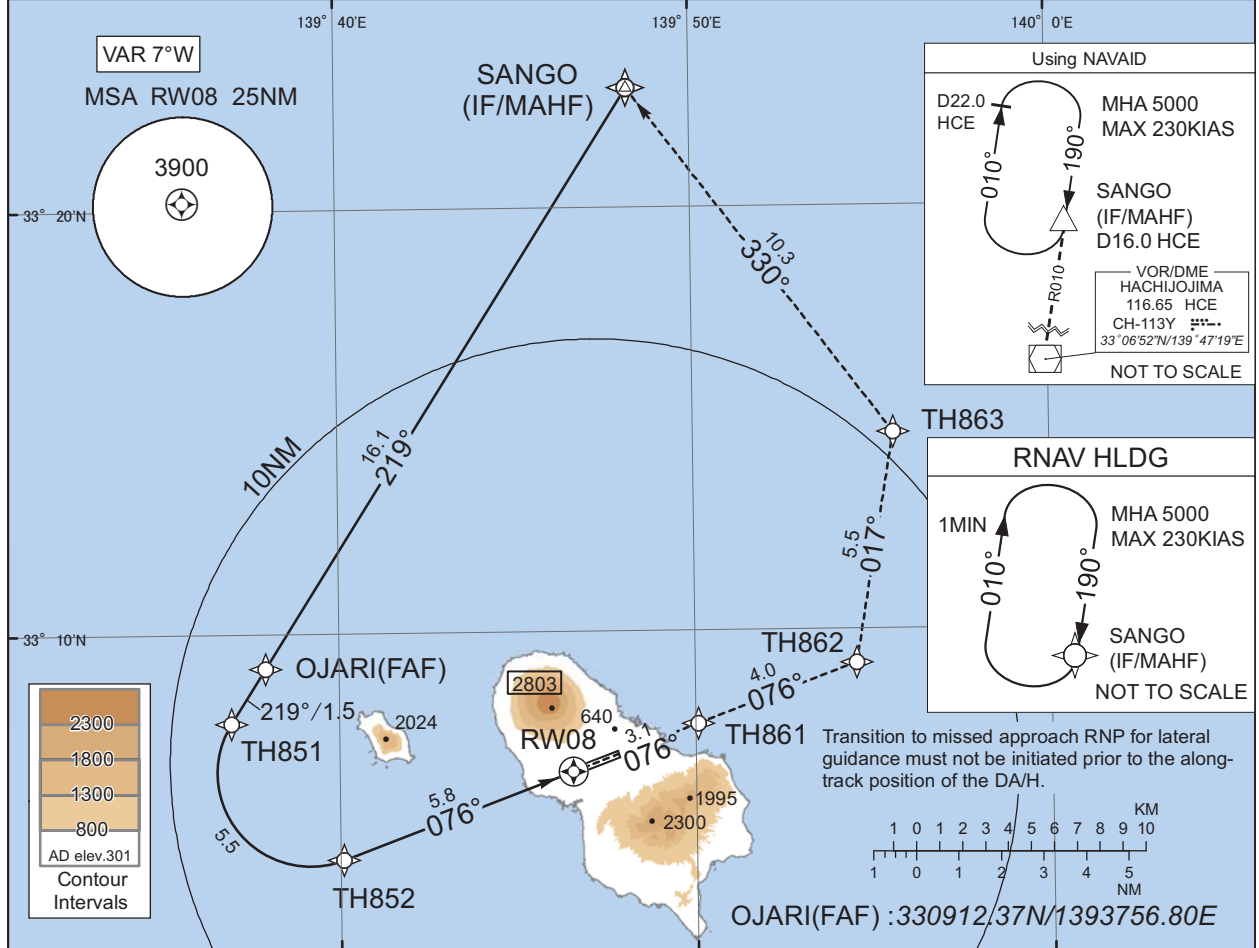

Missed APCH climb gradient MNM 5.0%

CAT	RNP 0.29		RNP 0.30	
	DA(H)	CMV	DA(H)	CMV
A	-	-	-	-
B	-	-	-	-
C	806(524)	2000	824(542)	2000
D	-	-	-	-

MINIMA with Missed APCH climb gradient of 2.5% are not established.

Authorization Required

CHANGE : PROC renamed.

INSTRUMENT APPROACH CHART

RJTH / HACHIJOJIMA

RNP Y RWY08(AR)

Coding Table

Serial Number	Path Descriptor	Waypoint Identifier	Fly Over	Course °M(°T)	Magnetic Variation	Distance (NM)	Turn Direction	Altitude (FT)	Speed (KIAS)	VPA/ RDH (°/FT)	RNP Value
001	IF	SANGO	-	-	-6.9	-	-	+5000	-	-	-
002	TF	OJARI	-	219 (212.3)	-6.9	16.1	-	4400	-	-	1.0
003	TF	TH851	-	219 (212.2)	-6.9	1.5	-	3914	-	-3.00	0.29 0.30
004	RF Center: THRF1 r=2.19NM	TH852	-	-	-6.9	5.5	L	2175	-	-3.00	0.29 0.30
005	TF	RW08	Y	076 (069.4)	-6.9	5.8	-	332	-	-3.00/50	0.29 0.30
006	TF	TH861	-	076 (069.5)	-6.9	3.1	-	-	-	-	0.29 0.30
007	TF	TH862	-	076 (069.5)	-6.9	4.0	-	-	-	-	1.0
008	TF	TH863	-	017 (009.6)	-6.9	5.5	-	-	-	-	1.0
009	TF	SANGO	-	330 (323.0)	-6.9	10.3	-	5000	-	-	1.0

Path	Waypoint Identifier	Inbound Course °M(°T)	Magnetic Variation	Outbound Time (MIN)	Turn Direction	Minimum Altitude (FT)	Maximum Altitude (FT)	Speed (KIAS)	RNP Value
Hold	SANGO	190 (182.8)	-6.9	1.0 (-14000)	R	5000	FL140	-230 (-14000)	1.0

Waypoint Coordinates

Waypoint Identifier	Coordinates	RF Arc Center Identifier	Coordinates
SANGO	332250.44N / 1394814.02E	THRF1	330644.49N / 1393910.78E
OJARI	330912.37N / 1393756.80E		
TH851	330754.90N / 1393658.54E		
TH852	330441.17N / 1394005.63E		
RW08	330643.03N / 1394633.07E		
TH861	330749.27N / 1395004.24E		
TH862	330913.15N / 1395432.21E		
TH863	331439.22N / 1395537.92E		

CHANGE : PROC renamed.

INSTRUMENT APPROACH CHART

RJTH / HACHIOJIMA

RNP Z RWY26(AR)

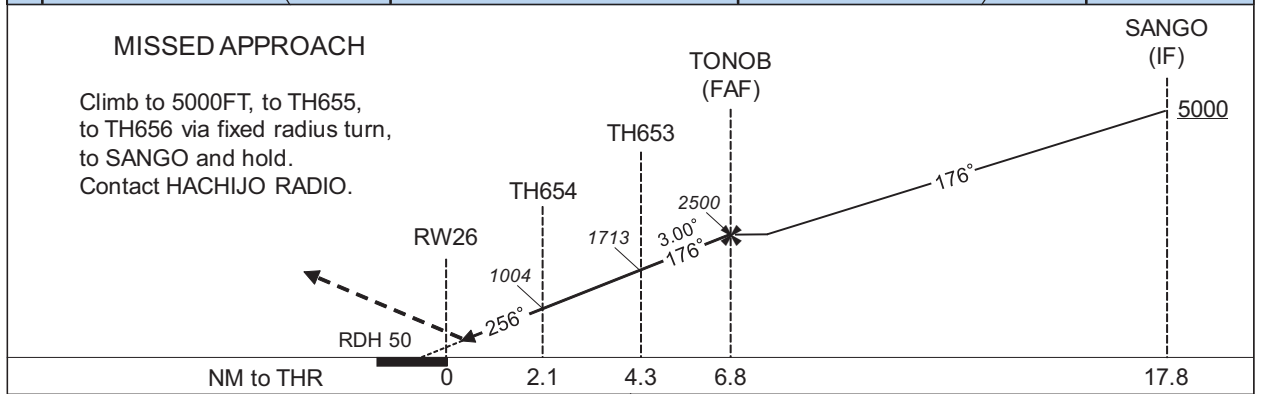
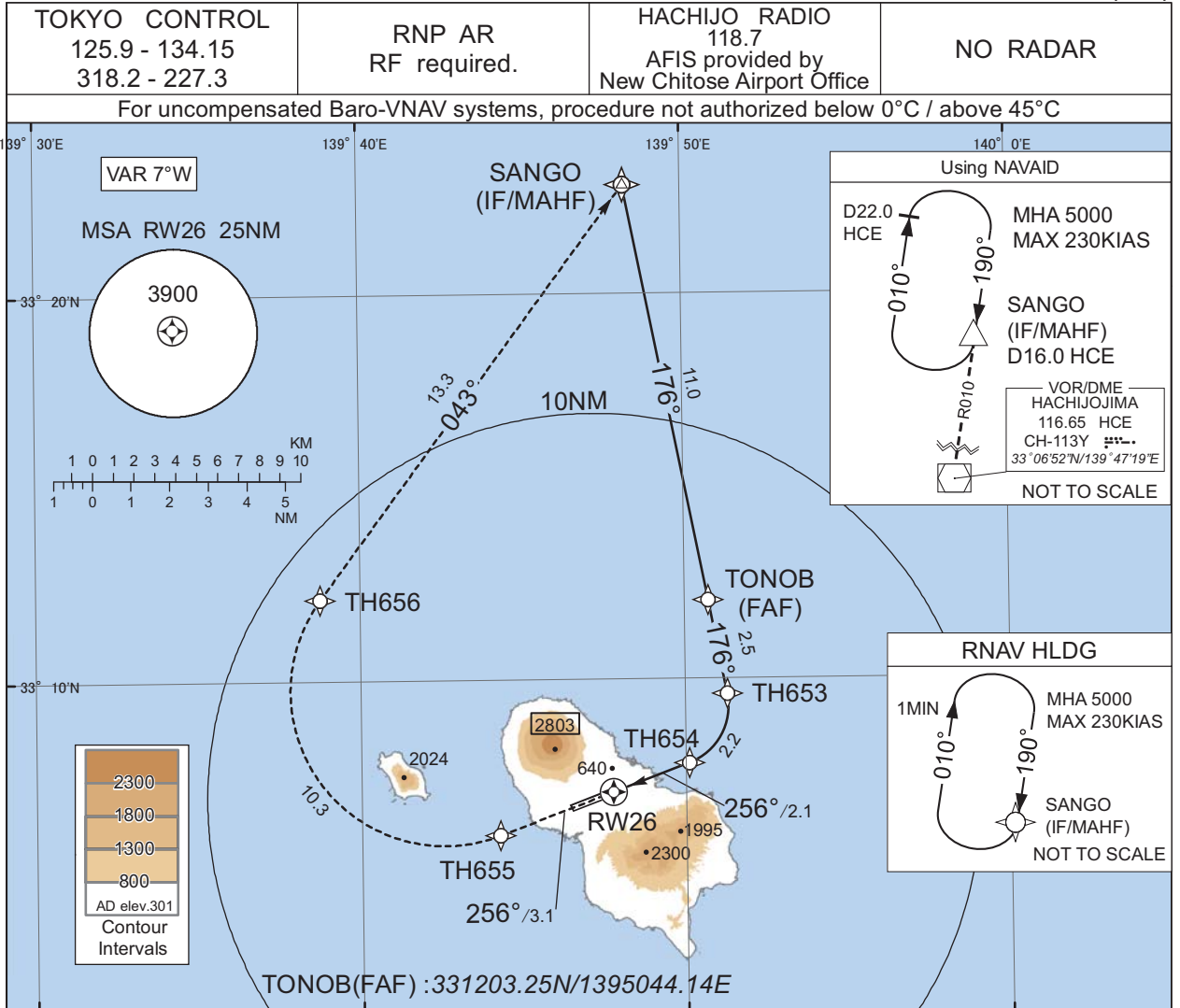

CHANGE : New PROC.

Missed APCH climb gradient MNM 5.0%

MINIMA	THR elev. 284		AD elev. 301	
	RNP 0.10		RNP 0.30	
CAT	DA(H)	CMV	DA(H)	CMV
A	-	-	-	-
B	-	-	-	-
C	545(261)	1200	844(560)	1600
D	-	-	-	-

Authorization Required

MINIMA with Missed APCH climb gradient of 2.5% are not established.

INSTRUMENT APPROACH CHART

RJTH / HACHIJOJIMA

RNP Z RWY26(AR)

Coding Table

Serial Number	Path Descriptor	Waypoint Identifier	Fly Over	Course °M(°T)	Magnetic Variation	Distance (NM)	Turn Direction	Altitude (FT)	Speed (KIAS)	VPA/RDH (°/FT)	RNP Value
001	IF	SANGO	-	-	-7.0	-	-	+5000	-	-	-
002	TF	TONOB	-	176 (169.0)	-7.0	11.0	-	2500	-	-	1.0
003	TF	TH653	-	176 (169.0)	-7.0	2.5	-	1713	-	-3.00	0.10 0.30
004	RF Center: THRF5 r=1.58NM	TH654	-	-	-7.0	2.2	R	1004	-	-3.00	0.10 0.30
005	TF	RW26	Y	256 (249.5)	-7.0	2.1	-	334	-	-3.00/50	0.10 0.30
006	TF	TH655	-	256 (249.5)	-7.0	3.1	-	-	-	-	0.10 0.30
007	RF Center: THRF6 r=4.00NM	TH656	-	-	-7.0	10.3	R	-	-	-	0.30
008	TF	SANGO	-	043 (036.4)	-7.0	13.3	-	5000	-	-	1.0

Path	Waypoint Identifier	Inbound Course °M(°T)	Magnetic Variation	Outbound Time (MIN)	Turn Direction	Minimum Altitude (FT)	Maximum Altitude (FT)	Speed (KIAS)	RNP Value
Hold	SANGO	190 (182.8)	-6.9	1.0 (-14000)	R	5000	FL140	-230 (-14000)	1.0

Waypoint Coordinates

Waypoint Identifier	Coordinates	RF Arc Center Identifier	Coordinates
SANGO	332250.44N / 1394814.02E	THRF5	330919.08N / 1394926.90E
TONOB	331203.25N / 1395044.14E	THRF6	330944.94N / 1394235.78E
TH653	330937.26N / 1395117.91E		
TH654	330749.94N / 1395006.37E		
RW26	330705.72N / 1394745.36E		
TH655	330559.88N / 1394415.73E		
TH656	331208.05N / 1393846.29E		

CHANGE : New PROC.

INSTRUMENT APPROACH CHART

RJTH / HACHIOJIMA

RNP Y RWY26(AR)

TOKYO CONTROL 125.9 - 134.15 318.2 - 227.3	RNP AR RF required.	HACHIOJO RADIO 118.7 AFIS provided by New Chitose Airport Office	NO RADAR
--	------------------------	---	----------

For uncompensated Baro-VNAV systems, procedure not authorized below 0°C / above 45°C

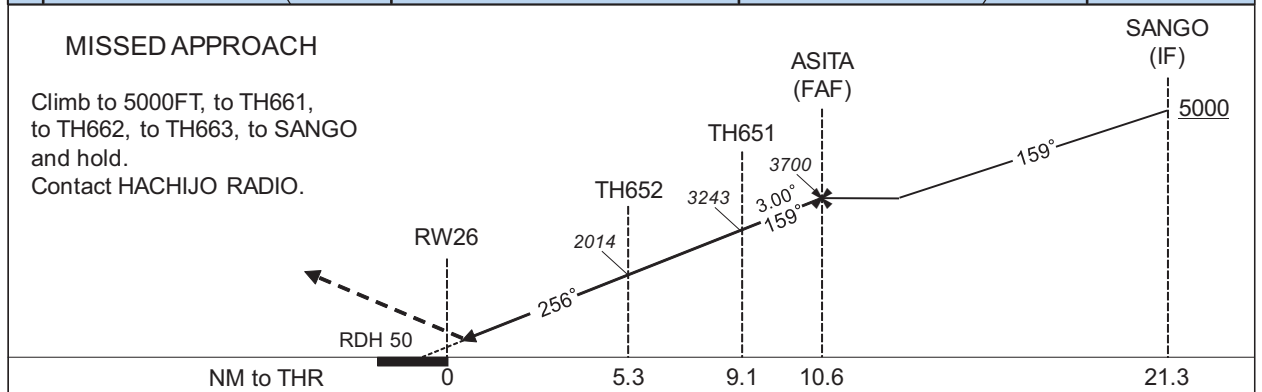
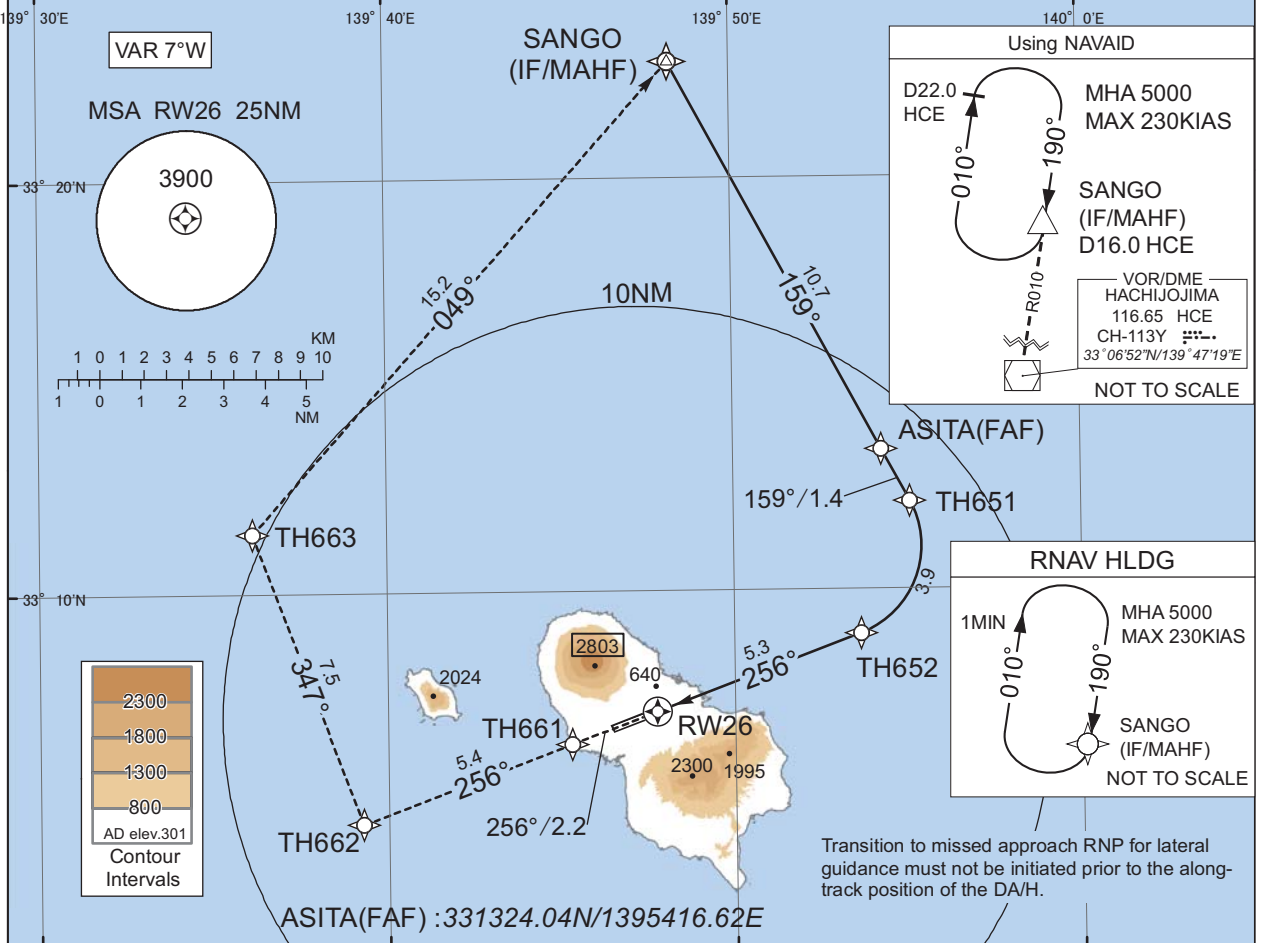

MINIMA

CAT	RNP 0.21		RNP 0.30	
	DA(H)	CMV	DA(H)	CMV
A	-	-	-	-
B	-	-	-	-
C	617(333)	1400	844(560)	1600
D	-	-	-	-

Authorization Required

CHANGE : PROC renamed.

MINIMA with Missed APCH climb gradient of 2.5% are not established.

INSTRUMENT APPROACH CHART

RJTH / HACHIJOJIMA

RNP Y RWY26(AR)

Coding Table

Serial Number	Path Descriptor	Waypoint Identifier	Fly Over	Course °M(°T)	Magnetic Variation	Distance (NM)	Turn Direction	Altitude (FT)	Speed (KIAS)	VPA/RDH (°/FT)	RNP Value
001	IF	SANGO	-	-	-6.9	-	-	+5000	-	-	-
002	TF	ASITA	-	159 (151.8)	-6.9	10.7	-	3700	-	-	1.0
003	TF	TH651	-	159 (151.9)	-6.9	1.4	-	3243	-	-3.00	0.21 0.30
004	RF Center: THRF2 r=2.26NM	TH652	-	-	-6.9	3.9	R	2014	-	-3.00	0.21 0.30
005	TF	RW26	Y	256 (249.5)	-6.9	5.3	-	334	-	-3.00/50	0.21 0.30
006	TF	TH661	-	256 (249.5)	-6.9	2.2	-	-	-	-	0.21 0.30
007	TF	TH662	-	256 (249.4)	-6.9	5.4	-	-	-	-	1.0
008	TF	TH663	-	347 (339.6)	-6.9	7.5	-	-	-	-	1.0
009	TF	SANGO	-	049 (041.6)	-6.9	15.2	-	5000	-	-	1.0

Path	Waypoint Identifier	Inbound Course °M(°T)	Magnetic Variation	Outbound Time (MIN)	Turn Direction	Minimum Altitude (FT)	Maximum Altitude (FT)	Speed (KIAS)	RNP Value
Hold	SANGO	190 (182.8)	-6.9	1.0 (-14000)	R	5000	FL140	-230 (-14000)	1.0

Waypoint Coordinates

Waypoint Identifier	Coordinates	RF Arc Center Identifier	Coordinates
SANGO	332250.44N / 1394814.02E	THRF2	331103.88N / 1395242.68E
ASITA	331324.04N / 1395416.62E		
TH651	331208.17N / 1395505.07E		
TH652	330856.50N / 1395339.00E		
RW26	330705.72N / 1394745.36E		
TH661	330619.39N / 1394517.79E		
TH662	330425.68N / 1393916.49E		
TH663	331127.97N / 1393608.44E		

CHANGE : PROC renamed.

RJTH / HACHIJOJIMA

Visual REP

VAR 7°W(2024) / 4°W

HACHIJO RADIO
118.7

10NM N

5NM from ARP
HACHIJOJIMA INFORMATION ZONE
At or below 3000FT



Webメルカトル図法(球体補正) / Web Mercator projection

CHANGE : VAR.

※図中に標高を示す数字がある場合、単位はメートル(m)である。The unit of measurement used to express elevation is meter(m).

Call sign	BRG / DIST from ARP	Remarks
10NM N	360°T / 10.0NM	海上 Over the sea

RJTH / HACHIOJIMA

LDG CHART

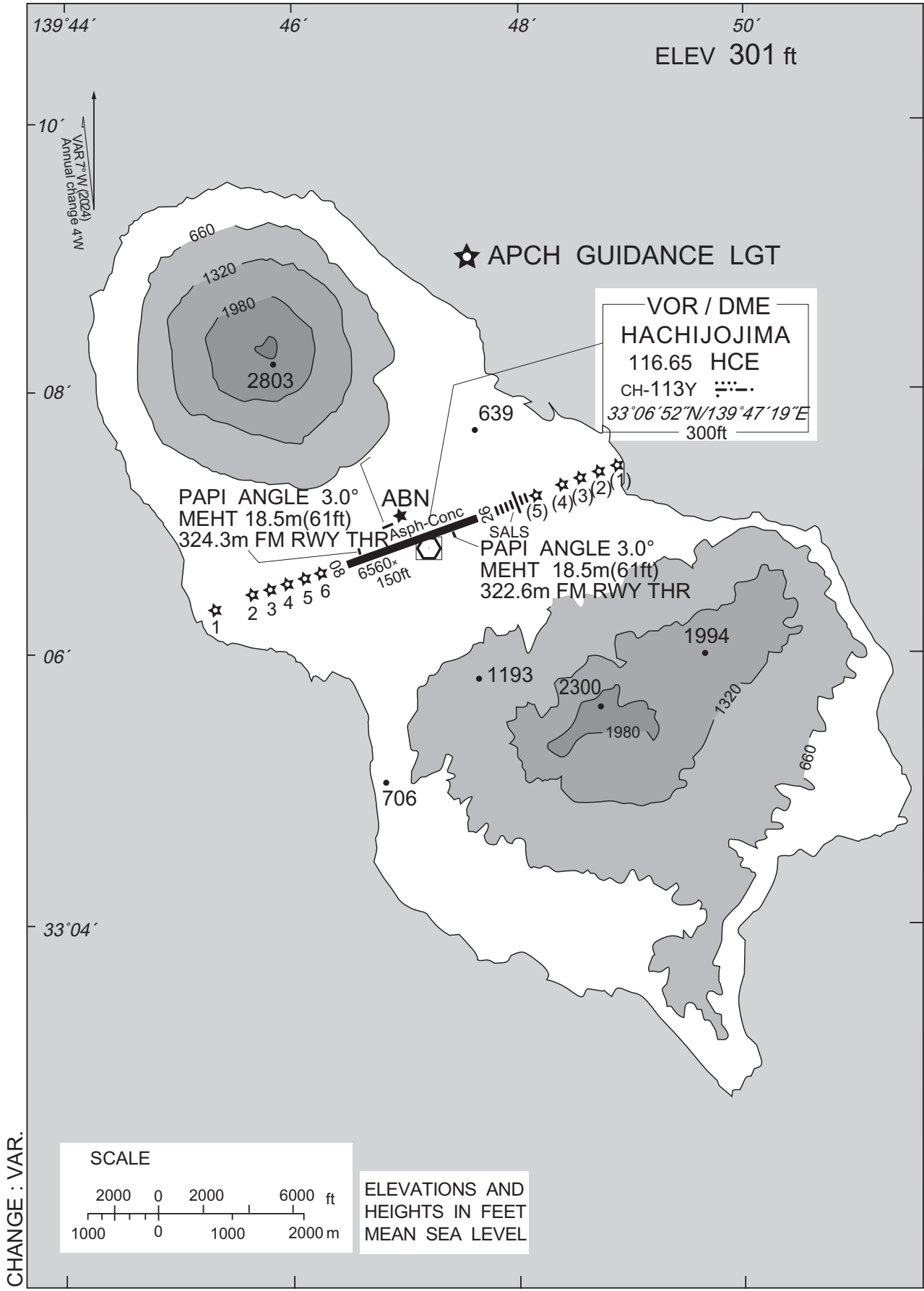

RJTH / HACHIOJIMA

Minimum Vectoring Altitude CHART

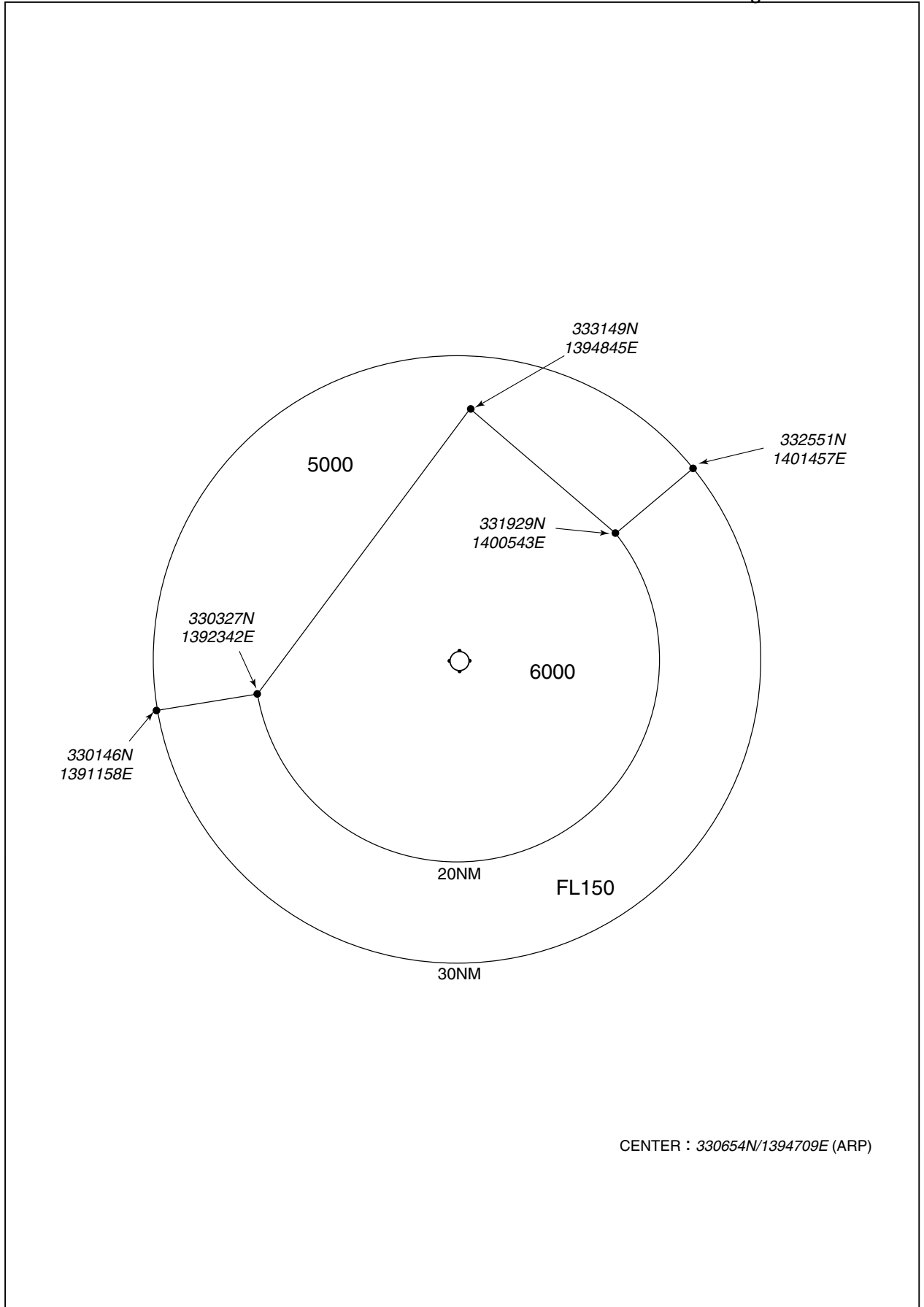

INTENTIONALLY LEFT BLANK