

AD 2 AERODROMES

RJTO AD 2.1 AERODROME LOCATION INDICATOR AND NAME

RJTO - OSHIMA

RJTO AD 2.2 AERODROME GEOGRAPHICAL AND ADMINISTRATIVE DATA

1	ARP coordinates and site at AD	344655N/1392137E 0.9km from RWY03 THR
2	Direction and distance from (city)	3.25km N from Oshima town office
3	Elevation/ Reference temperature	124FT / 29 °C (2004-2008)
4	Geoid undulation at AD ELEV PSN	129FT
5	MAG VAR/ Annual change	8° W(2024) / 4' W
6	AD Administration, address, telephone, telefax, telex, AFS, e-mail and/or Web-site addresses	Tokyo Metropolitan Government. Public AP. 270, Kitanoyama, Aza, Motomachi, Oshima-machi, Tokyo TEL: 04992-2-1400 FAX: 04992-2-2480 e-mail: TOCAirport1964@section.metro.tokyo.jp
7	Types of traffic permitted(IFR/VFR)	IFR/VFR
8	Remarks	Nil

RJTO AD 2.3 OPERATIONAL HOURS

1	AD Administration	2330 - 0830 [2330 28th FEB* - 0830 30th SEP] 2330 - 0730 [2330 30th SEP - 0730 28th FEB*] * In the case of a leap year, 29th FEB.
2	Customs and immigration	On request Customs: 03-3599-6286 Immigration: 0570-034259 (Department Number 210)
3	Health and sanitation	Quarantine(human): On request(03-3599-1515) Quarantine(animal, plant): Nil
4	AIS Briefing Office	Nil
5	ATS Reporting Office(ARO)	Nil
6	MET Briefing Office	H24 (TOKYO)
7	ATS	2330 - 0830 [2330 28th FEB* - 0830 30th SEP] 2330 - 0730 [2330 30th SEP - 0730 28th FEB*] * In the case of a leap year, 29th FEB. Remarks: AFIS provided by New Chitose Airport Office.
8	Fuelling	2330 - 0830 [2330 28th FEB* - 0830 30th SEP] 2330 - 0730 [2330 30th SEP - 0730 28th FEB*] (On request) * In the case of a leap year, 29th FEB.
9	Handling	2330 - 0830 [2330 28th FEB* - 0830 30th SEP] 2330 - 0730 [2330 30th SEP - 0730 28th FEB*] * In the case of a leap year, 29th FEB.
10	Security	2330 - 0830 [2330 28th FEB* - 0830 30th SEP] 2330 - 0730 [2330 30th SEP - 0730 28th FEB*] * In the case of a leap year, 29th FEB.
11	De-icing	Nil
12	Remarks	Nil

RJTO AD 2.4 HANDLING SERVICES AND FACILITIES

1	Cargo-handling facilities	Nil
2	Fuel/ oil types	Fuel : JET A-1, Avgas 100LL
3	Fuelling facilities/ capacity	Fuel truck, Fuel tank
4	De-icing facilities	Nil
5	Hangar space for visiting aircraft	Nil
6	Repair facilities for visiting aircraft	Nil
7	Remarks	Nil

RJTO AD 2.5 PASSENGER FACILITIES

1	Hotels	Nil
2	Restaurants	Nil
3	Transportation	Nil
4	Medical facilities	Nil
5	Bank and Post Office	Nil
6	Tourist Office	Nil
7	Remarks	Nil

RJTO AD 2.6 RESCUE AND FIRE FIGHTING SERVICES

1	AD category for fire fighting	CAT 6
2	Rescue equipment	Chemical fire fighting truck x 2
3	Capability for removal of disabled aircraft	Nil
4	Remarks	Nil

RJTO AD 2.7 SEASONAL AVAILABILITY-CLEARING

1	Types of clearing equipment	Not Applicable
2	Clearance priorities	Nil
3	Remarks	Nil

RJTO AD 2.8 APRONS, TAXIWAYS AND CHECK LOCATIONS DATA

1	Apron surface and strength	NR.1 APRON: Surface : Asphalt Concrete, Strength:PCN 35/F/C/X/T NR.2 APRON: Surface : Asphalt Concrete, Strength:PCN 12/F/C/Y/T NR.3 APRON: Surface : Asphalt Concrete, Strength:PCN 12/F/C/Y/T NR.4 APRON: Surface : Concrete, Strength:AUW 4300kg / 0.3MPa
2	Taxiway width, surface and strength	T-1: Width 23m, Surface:Asphalt Concrete, Strength:PCN 35/F/C/X/T T-2,T-3: Width 18m, Surface:Asphalt Concrete, Strength:PCN 12/F/C/Y/T T-4: Width 8m, Surface:Asphalt Concrete, Strength:AUW 4300kg / 0.3MPa
3	ACL and elevation	Not available
4	VOR checkpoints	Not available
5	INS checkpoints	(Spot NR) 1 344658.86N/1392145.55E 2 344657.03N/1392144.74E 3 344655.85N/1392144.48E 2L 344658.08N/1392146.62E 2R 344657.25N/1392146.26E 3L 344656.43N/1392145.89E 3R 344655.61N/1392145.52E 27 344654.26N/1392145.43E 28 344653.68N/1392143.96E 29 344653.45N/1392145.03E
6	Remarks	Nil

RJTO AD 2.9 SURFACE MOVEMENT GUIDANCE AND CONTROL SYSTEM AND MARKINGS

1	Use of aircraft stand ID signs, TWY guide lines and Visual docking/ parking guidance system of aircraft stands	Nil
2	RWY and TWY markings and LGT	RWY: RWY03/21 (Marking): RWY designation, RWY CL, RWY THR, RWY middle point, Aiming point, TDZ, RWY side stripe (LGT):RCLL, REDL, RTHL, RENL TWY: (Marking): TWY CL, TWY side stripe (LGT): TWY edge LGT, TWY CL LGT, Taxiing guidance sign
3	Stop bars	Nil
4	Remarks	(Marking) Overrun area (LGT) Apron flood LGT

RJTO AD 2.10 AERODROME OBSTACLES

In Area2 See Obstacle data

In Area3 To be developed

RJTO AD 2.11 METEOROLOGICAL INFORMATION PROVIDED

1	Associated MET Office	TOKYO
2	Hours of service MET Office outside hours	H24 (TOKYO)
3	Office responsible for TAF preparation Periods of validity	Nil
4	Trend forecast Interval of issuance	Nil
5	Briefing/ consultation provided	Briefing is available upon inquiry at TOKYO
6	Flight documentation Language(s) used	C En
7	Charts and other information available for briefing or consultation	S ₆ , U ₈₅ , U ₇ , U ₅ , U ₃ , U ₂₅ , U ₂ /T _r , P _S , P ₅ , P ₃ , P ₂₅ , P _{SWE} , P _{SWF} , P _{SWG} , P _{SWI} , P _{SWM} , P _{SW} (domestic), E, C, W _E , W _F , W _G , W _I , W, N
8	Supplementary equipment available for providing information	Nil
9	ATS units provided with information	RADIO
10	Additional information (limitation of service, etc.)	Nil

RJTO AD 2.12 RUNWAY PHYSICAL CHARACTERISTICS

Designations RWY NR	TRUE BRG	Dimensions of RWY(M)	Strength(PCN) and surface of RWY	THR coordinates THR geoid undulation	THR elevation and highest elevation of TDZ of precision APP RWY
1	2	3	4	5	6
03	020.15°	1800×45	PCN 35/F/C/X/T Asphalt-Concrete	344627.00N 1392124.87E	THR ELEV: 138ft
21	200.15°	1800×45	PCN 35/F/C/X/T Asphalt-Concrete	344722.84N 1392149.25E	THR ELEV: 117ft
Slope of RWY	Strip Dimensions(M)	RESA(Overrun) Dimensions(M)	Remarks		
7	10	11	14		
See AD2.24 AD chart	1920×150 1920×150	90×90 90×90	RWY grooving:1800m × 30m		

RJTO AD 2.13 DECLARED DISTANCES

RWY Designator	TORA (m)	TODA (m)	ASDA (m)	LDA (m)	Remarks
1	2	3	4	5	6
03	1800	1800	1800	1800	Nil
21	1800	1800	1800	1800	Nil

RJTO AD 2.14 APPROACH AND RUNWAY LIGHTING

RWY Designator	APCH LGT type LEN INTST	RTHL Color WBAR	PAPI (VASIS) Angle DIST FM THR MEHT	RTZL LEN	RCLL LEN Spacing Color INTST	REDL LEN Spacing Color INTST	RENL Color WBAR	STWL LEN Color
1	2	3	4	5	6	7	8	9
03	SALS (*1) 420m LIH	Green Nil	PAPI 3.0° /LEFT 355.8m 49ft		1800m 30m Coded Color (White/Red) LIH	1800m 60m Coded Color (White/Yellow) LIH	Red	Nil (*2)
21		Green Nil	PAPI 3.0° /LEFT 276.9m 49ft		1800m 30m Coded Color (White/Red) LIH	1800m 60m Coded Color (White/Yellow) LIH	Red	Nil (*2)
Remarks								
10								
SALS with RAI(LEN:480m)(*1) Overrun area edge LGT(LEN:30m Color:Red)(*2) RWY THR ID LGT For RWY21 THR(Color:White)								

RJTO AD 2.15 OTHER LIGHTING, SECONDARY POWER SUPPLY

1	ABN/IBN location, characteristics and hours of operation	ABN: 344647N/1392142E, White/Green EV4.3sec, HO
2	LDI location and LGT Anemometer location and LGT	LDI:Nil Anemometer: RWY03:340m from RWY03 THR, lighted RWY21:300m from RWY21 THR. lighted
3	TWY edge and centerline lighting	TWY edge and center line lights installed, see AD2.9
4	Secondary power supply/switch-over time	Within 15 sec : All lights
5	Remarks	WDI LGT

RJTO AD 2.16 HELICOPTER LANDING AREA

Nil

RJTO AD 2.17 ATS AIRSPACE

Designation and lateral limits		Vertical limits (ft)	Airspace classification	ATS unit call sign Language	Remarks
1		2	3	4	6
Oshima Information Zone	Area within a radius of 5nm(9km) of Oshima ARP	3,000 or below	E	Oshima Radio En	

RJTO AD 2.18 ATS COMMUNICATION FACILITIES

Service designation	Call sign	Frequency	Hours of operation	Remarks
1	2	3	4	5
AFIS	Oshima Radio	118.6MHz	2330 - 0830 [2330 28th FEB* - 0830 30th SEP] 2330 - 0730 [2330 30th SEP - 0730 28th FEB*] * In the case of a leap year, 29th FEB.	Operated by New Chitose Airport Office

RJTO AD 2.19 RADIO NAVIGATION AND LANDING AIDS

Type of aid (VOR declination)	ID	Frequency	Hours of operation	Position of transmitting antenna coordinates	Elevation of DME transmitting antenna	Remarks
1	2	3	4	5	6	7
VOR (7°W/2017)	OSE	109.85MHz	H24	344715.87N/ 1392153.46E		VOR/DME unusable: 110°-130° beyond 15NM BLW 5000ft
DME	OSE	1122MHz (CH-35Y)	H24	344715.87N/ 1392153.46E	156ft	150°-180° beyond 10NM BLW 5000ft 180°-190° beyond 15NM BLW 5000ft VOR unusable: 130°-150° beyond 15NM BLW 5000ft DME unusable: 130°-150° beyond 10NM BLW 5000ft
LOC 03	IOS	109.35MHz	2330 - 0830 [2330 28th FEB* - 0830 30th SEP] 2330 - 0730 [2330 30th SEP - 0730 28th FEB*] * In the case of a leap year, 29th FEB.	344730.00N/ 1392152.44E		LOC: 235m (771FT) away FM RWY21 THR, BRG 027°(MAG) Unusable: beyond 20° E(150Hz) side of course
LOC-DME 03	IOS	1117MHz	2330 - 0830 [2330 28th FEB* - 0830 30th SEP] 2330 - 0730 [2330 30th SEP - 0730 28th FEB*] * In the case of a leap year, 29th FEB.	344729.80N/ 1392149.42E	129ft	DME: 203m(666FT) away FM RWY21 THR, 70m(230FT) W of RCL

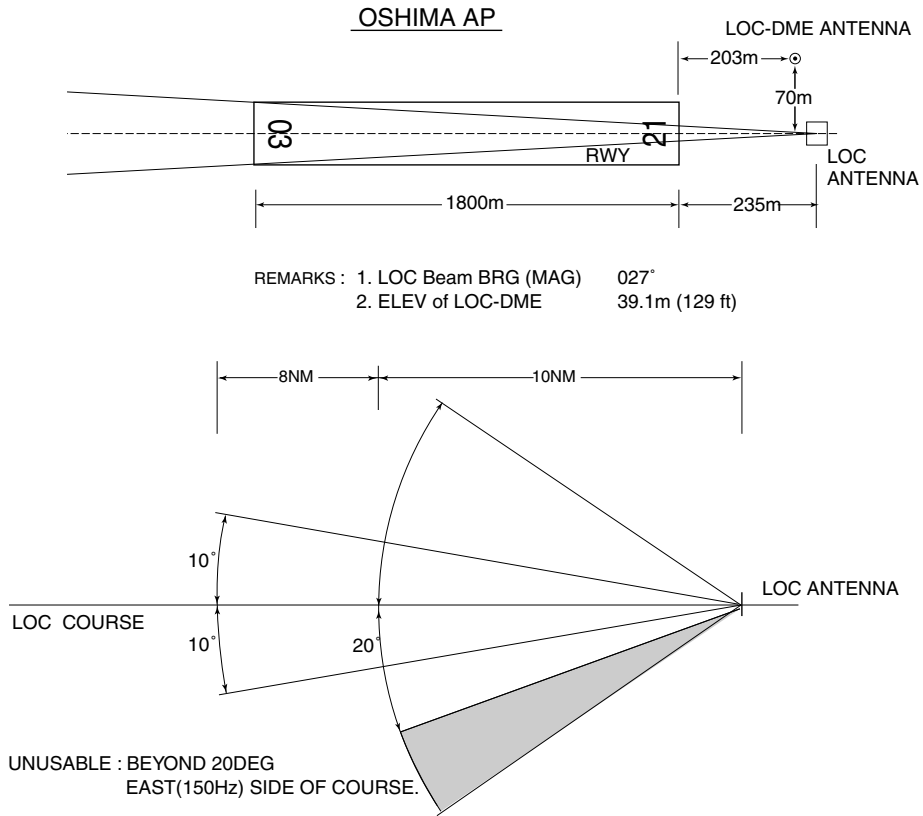

RJTO AD 2.20 LOCAL TRAFFIC REGULATIONS

1. Airport regulations

Nil

2. Taxiing to and from stands

Nil

3. Parking area for small aircraft(General aviation)

Nil

4. Parking area for helicopters

Nil

5. Apron - taxiing during winter conditions

Nil

6. Taxiing - limitations

Nil

7. School and training flights - technical test flights - use of runways

On use of this airport by flight training, the administrator's prior permission is required.

8. Helicopter traffic - limitation

Nil

9. Removal of disabled aircraft from runways

Nil

RJTO AD 2.21 NOISE ABATEMENT PROCEDURES

Nil

RJTO AD 2.22 FLIGHT PROCEDURES

TAKE OFF MINIMA

	RWY	ACFT CAT	REDL & RCLL		REDL or RCLL or RCL Marking		NIL (DAYTIME ONLY)	
			CEIL-RVR	CEIL-VIS	CEIL-RVR	CEIL-VIS	CEIL-RVR	CEIL-VIS
Multi-Engine ACFT with TKOF ALTN AP Filed	03	A,B,C,D	-	300'-2400m 200'-1600m*	-	300'-2400m 200'-1600m*	-	300'-2400m 200'-1600m*
	21	A,B,C,D	-	200'-2400m	-	200'-2400m	-	200'-2400m
OTHER	03	A,B,C,D	AVBL LDG MINIMA					
	21	A,B,C,D						

*Applicable in case of climbing with 8.7% gradient up to 500FT.

RJTO AD 2.23 ADDITIONAL INFORMATION

Nil

RJTO AD 2.24 CHARTS RELATED TO AN AERODROME

Aerodrome/Heliport Chart
 Standard Departure Chart - Instrument (HATSU)
 Standard Departure Chart - Instrument (OSHIMA REVERSAL)
 Instrument Approach Chart (LOC RWY03)
 Instrument Approach Chart (VOR A)
 Instrument Approach Chart (VOR B)
 Other Chart (Visual REP)
 Other Chart (LDG CHART)
 Other Chart (MVA CHART)

RJTO / OSHIMA

AD CHART

CHANGE : NR.4 APRON installed. RWY HLDG PSN marking for TWY T-2, T-3 relocated. TWY EDGE LGT for T-2 abolished. VAR.

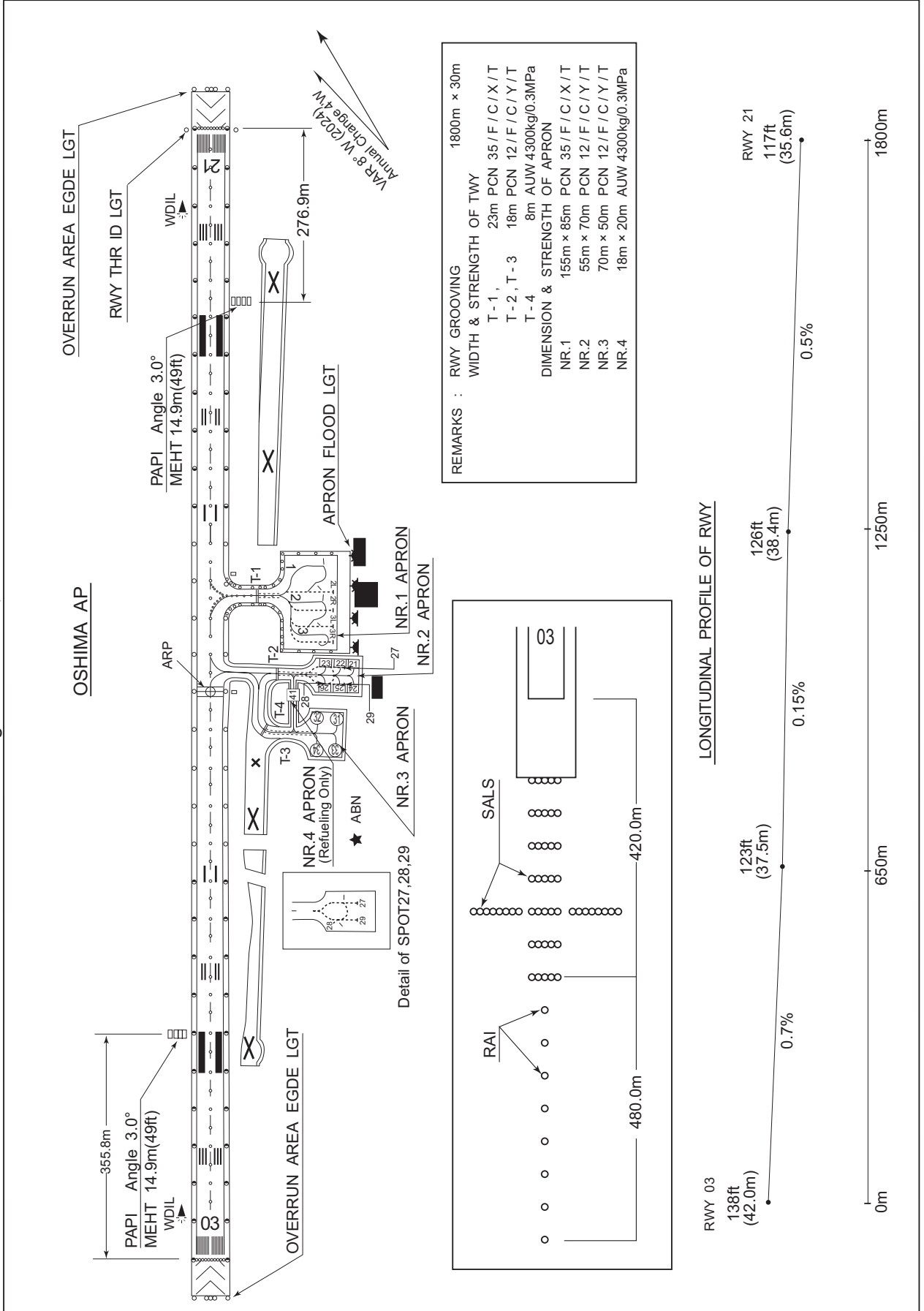

STANDARD DEPARTURE CHART -INSTRUMENT

RJTO / OSHIMA

SID

HATSU FOUR DEPARTURE

RWY03 : Climb RWY HDG to 800FT, turn right, climb...

RWY21 : Climb RWY HDG to 1400FT, turn right, direct to OSE VOR/DME,...
 ...via OSE R037 to HATSU.

Cross OSE 10.0DME at or above 3000FT.

Note RWY03 : In case of climbing with 8.7% gradient up to 500FT, another TKOF
 WX MINIMA is applicable.

OBST ALT 394FT located at 0.6NM 049° FM end of RWY03.

Note RWY21 : 4.2% climb gradient required up to 1400FT.

OBST ALT 1444FT located at 2.2NM 165° FM end of RWY21

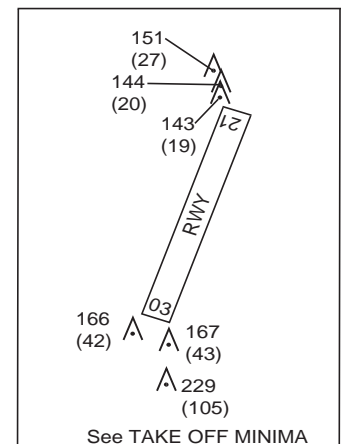
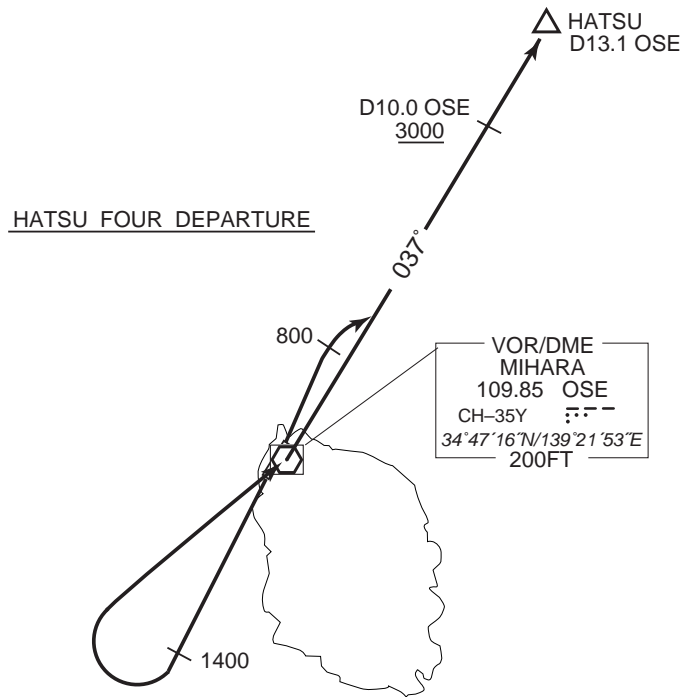

STANDARD DEPARTURE CHART -INSTRUMENT

RJTO / OSHIMA

SID

OSHIMA REVERSAL FOUR DEPARTURE

RWY03: Climb RWY HDG to 1100FT, turn left,...

RWY21: Climb RWY HDG to 1400FT, turn right,...

...direct to OSE VOR/DME.

Cross OSE VOR/DME at or above 4000FT.

Note RWY03 : In case of climbing with 8.7% gradient up to 500FT, another TKOF
WX MINIMA is applicable.

OBST ALT 394FT located at 0.6NM 049°FM end of RWY03.

Note RWY21 : 4.2% climb gradient required up to 1400FT.

OBST ALT 1444FT located at 2.2NM 165°FM end of RWY21

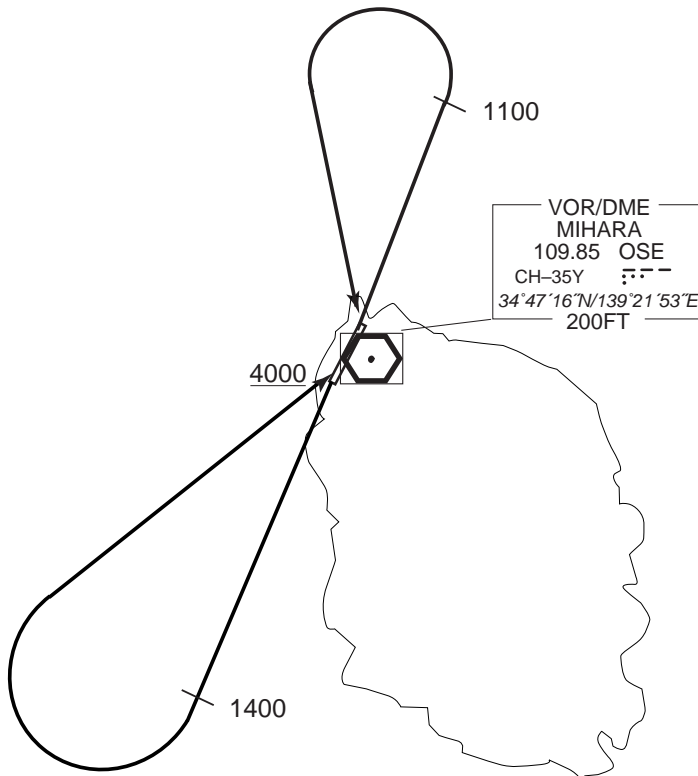

OSHIMA REVERSAL FOUR DEPARTURE

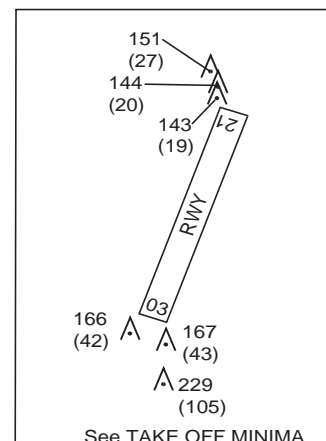

INSTRUMENT APPROACH CHART

RJTO / OSHIMA

LOC RWY03

TOKYO RADAR 124.0 – 295.9 119.1 – 232.2	LOC 109.35 IOS $\ddot{--}$ LOC-DME CH-30Y	OSHIMA RADIO 118.6 AFIS provided by New Chitose Airport Office.	NO RADAR
---	---	--	----------

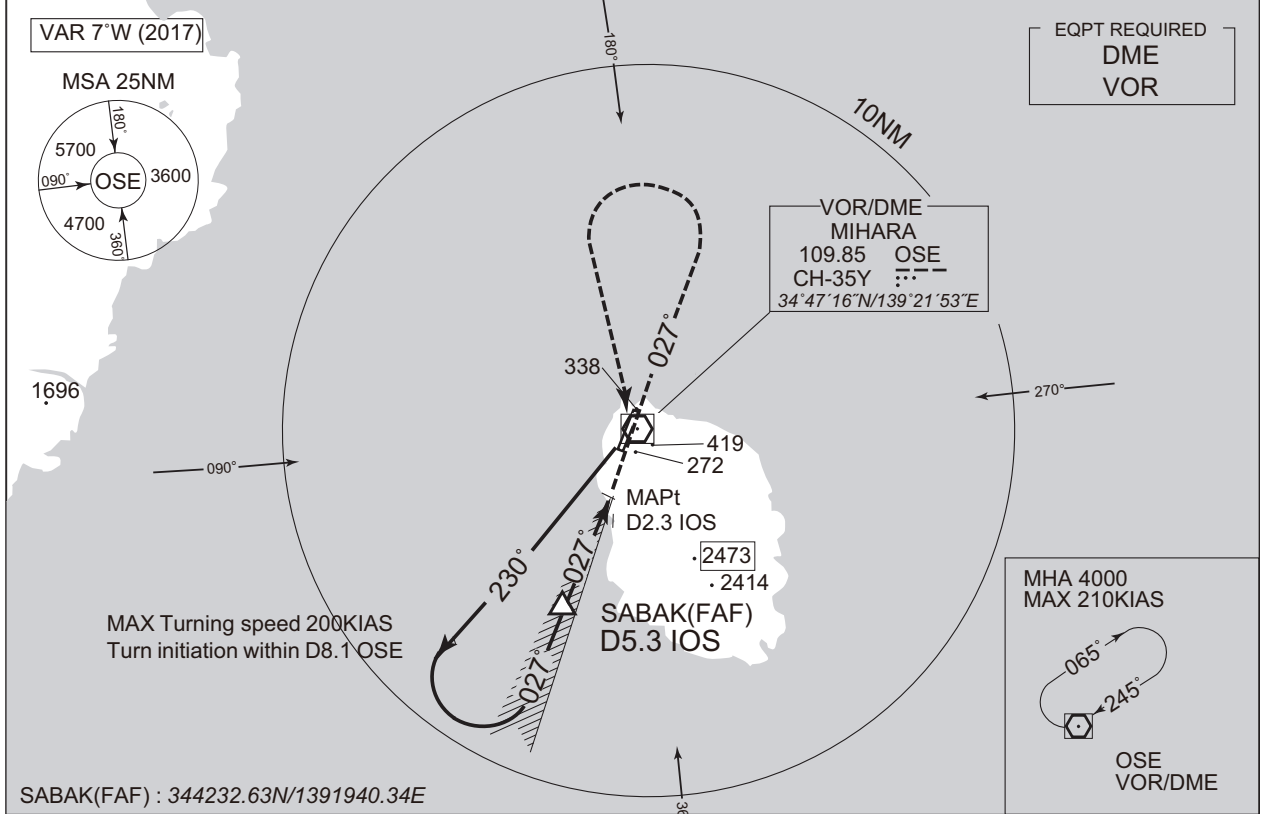

CHANGE : Secondary FREQ of OSHIMA RADIO abolished. AFIS unit added.

SABAK(FAF) : 344232.63N/1391940.34E

NM to IOS	FAF	5	4	3	MAPt
ALT (3.0° APCH Path)	1515	1435	1117	798	-

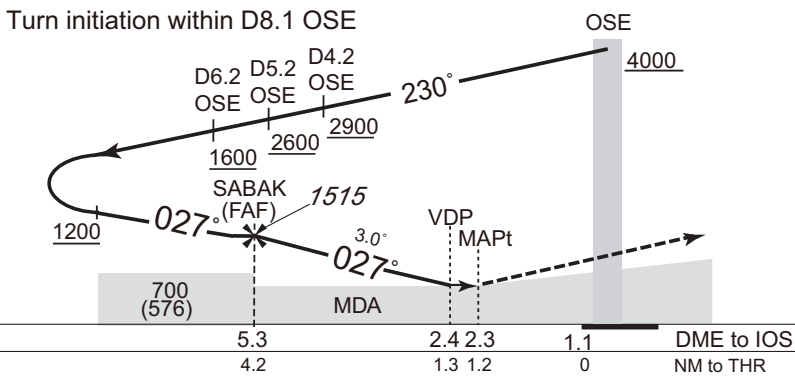

MISSED APPROACH
 Climb to 1700FT on HDG027°,
 turn left, direct to OSE VOR/DME
 and hold at 4000FT.
 Contact OSHIMA RADIO.
 Timing not authorized for defining the MAPt.

Missed APCH climb gradient MNM3.0%

MINIMA		THR elev. 138	AD elev. 124
CAT	MDA(H)		CIRCLING
	MDA(H)	CMV	MDA(H) VIS
A	570 (446)	900	720 (596) 1600
B		1000	
C			1400
D			

MINIMA with Missed APCH climb gradient of 2.5% are not established.
 Circling to WEST side of RWY only.

INSTRUMENT APPROACH CHART

RJTO / OSHIMA

VOR A

TOKYO RADAR
124.0 – 295.9
119.1 – 232.2

MIHARA VOR/DME
109.85 OSE
CH-35Y
34°47'16"N / 139°21'53"E

OSHIMA RADIO
118.6
AFIS provided by
New Chitose Airport Office.

NO RADAR

VAR 7°W (2017)

EQPT REQUIRED
DME

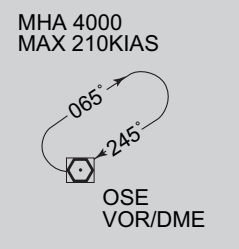
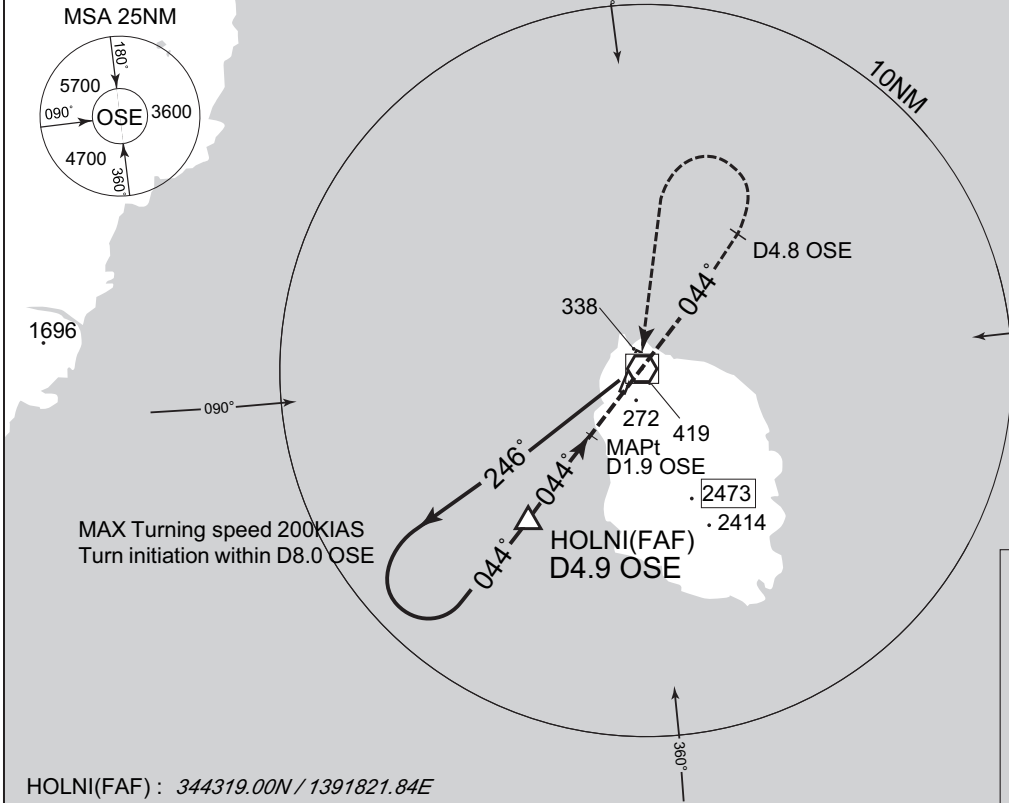
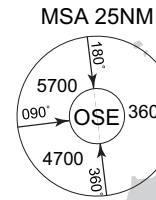

HOLNI(FAF) : 344319.00N / 1391821.84E

Turn initiation within D8.0 OSE

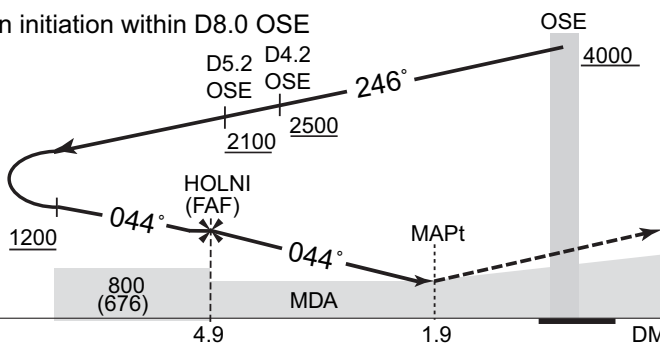

MISSED APPROACH

Climb via OSE R044 to OSE 4.8DME, turn left, direct to OSE VOR/DME and hold at 4000FT.
Contact OSHIMA RADIO.

Timing not authorized for defining the MAPt.

MINIMA		AD elev. 124
CAT	CIRCLING	
	MDA(H)	VIS
A	720 (596)	1600
B		2400
C		3200
D	730 (606)	

Circling to WEST side of RWY only.

CHANGE : Secondary FREQ of OSHIMA RADIO abolished. AFIS unit added.

INSTRUMENT APPROACH CHART

RJTO / OSHIMA

VOR B

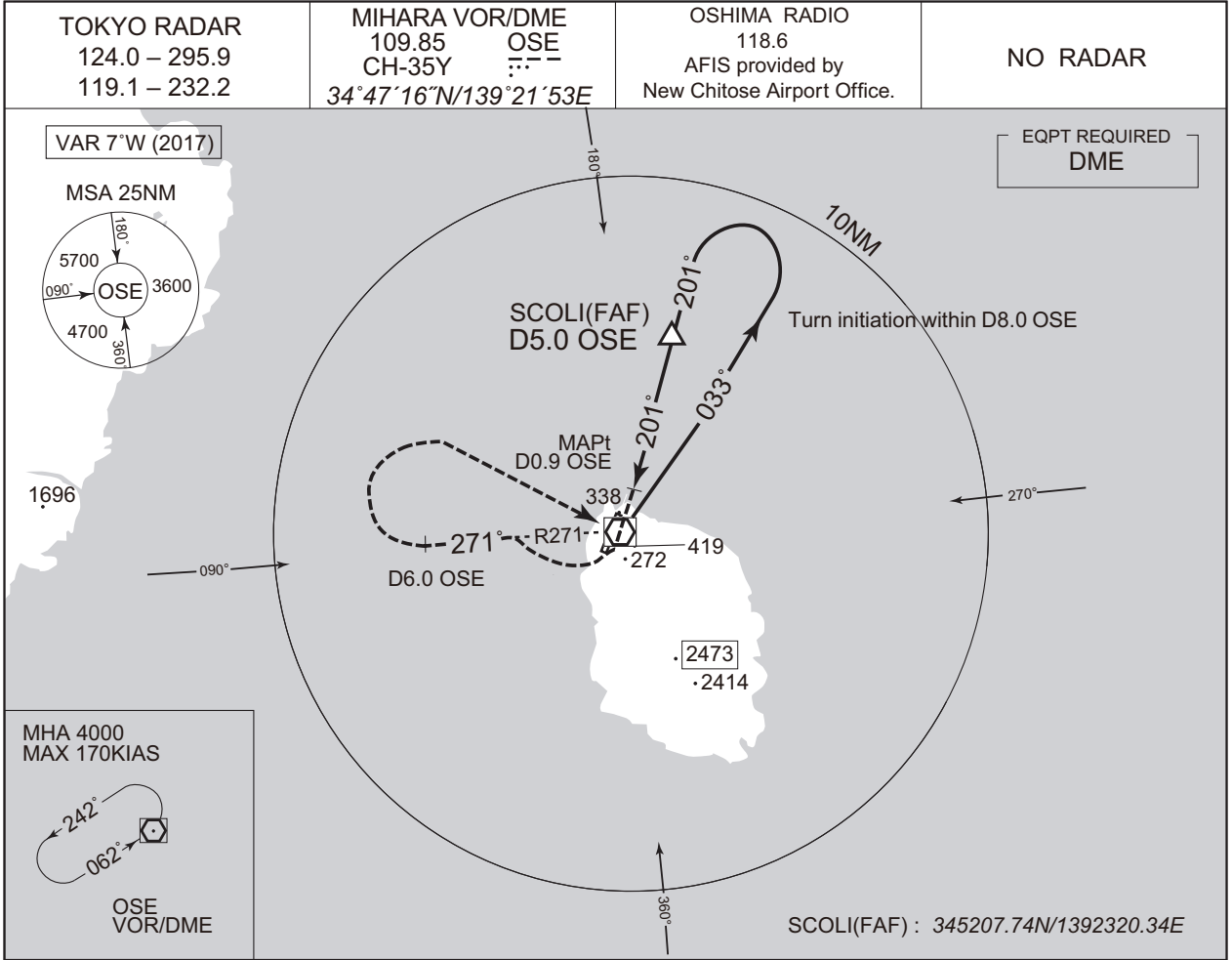

CHANGE : Secondary FREQ of OSHIMA RADIO abolished. AFIS unit added.

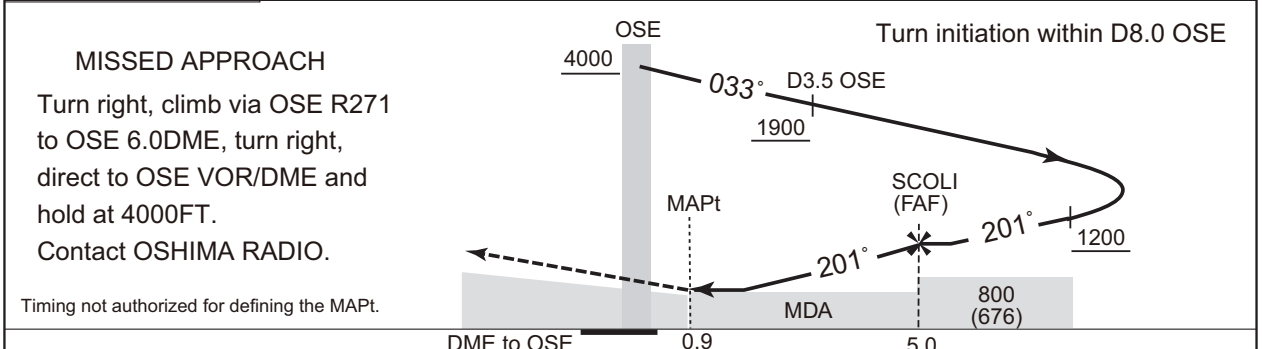

Missed APCH climb gradient MNM3.0%

MINIMA		AD elev. 124	
CAT	CIRCLING		VIS
	MDA(H)	VIS	
A	720 (596)	1600	
B			
C	-	-	
D	-	-	

MINIMA with Missed APCH climb gradient of 2.5% are not established.
 Circling to WEST side of RWY only.

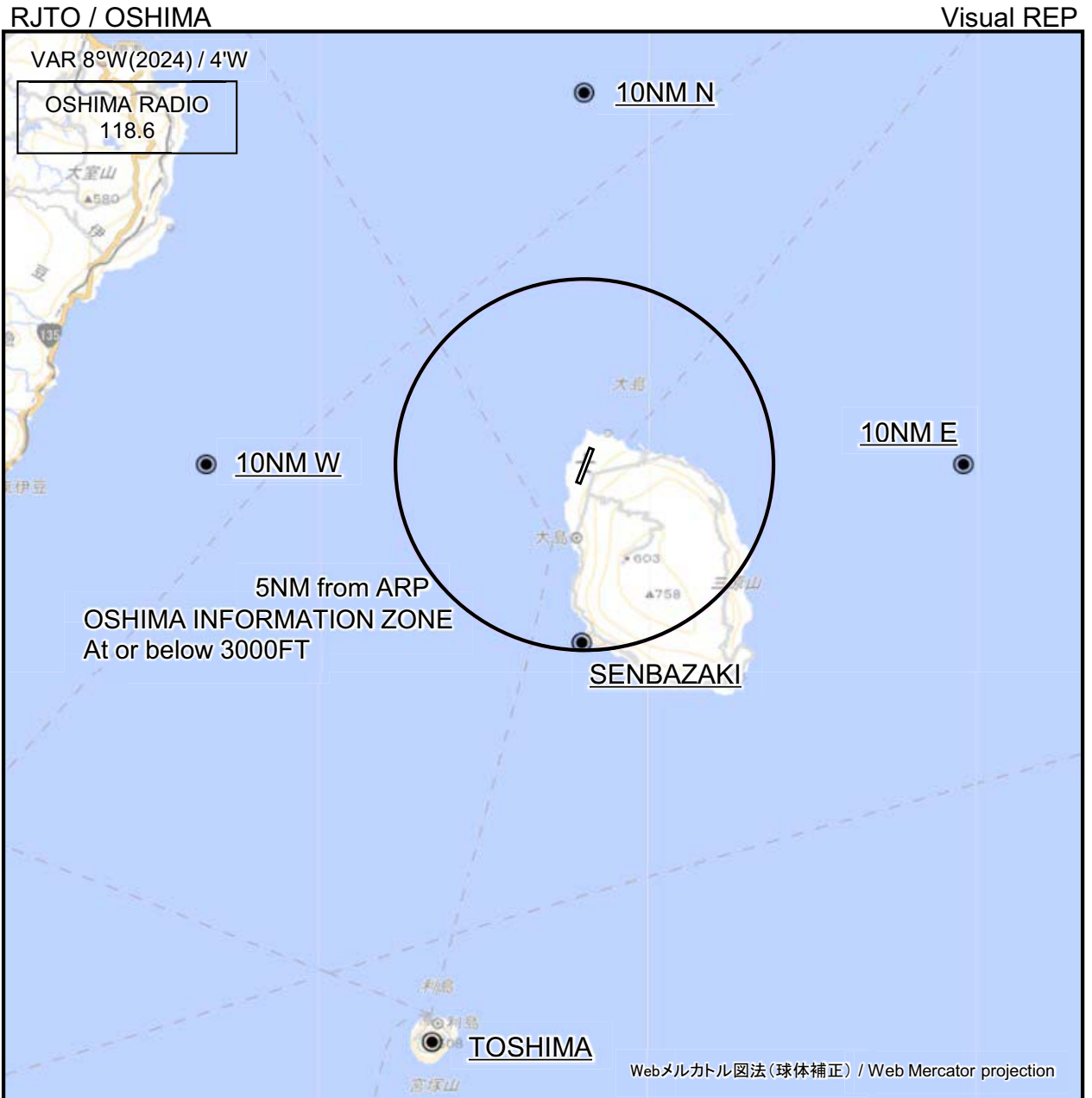

※図中に標高を示す数字がある場合、単位はメートル(m)である。The unit of measurement used to express elevation is meter(m).

Call sign	BRG / DIST from ARP	Remarks
10NM N	360°T / 10.0NM	海上 Over the sea
10NM E	090°T / 10.0NM	海上 Over the sea
10NM W	270°T / 10.0NM	海上 Over the sea
千波崎 Senbazaki	181°T / 4.8NM	岬 Cape
利島 Toshima	194°T / 16.1NM	宮塚山 Mt. Miyatsuka

CHANGE : VAR.

NOTE: In the SE direction of the airport, A/G COM from Oshima Radio is blinded by Mt Mihara(2,487ft)

RJTO / OSHIMA

LDG CHART

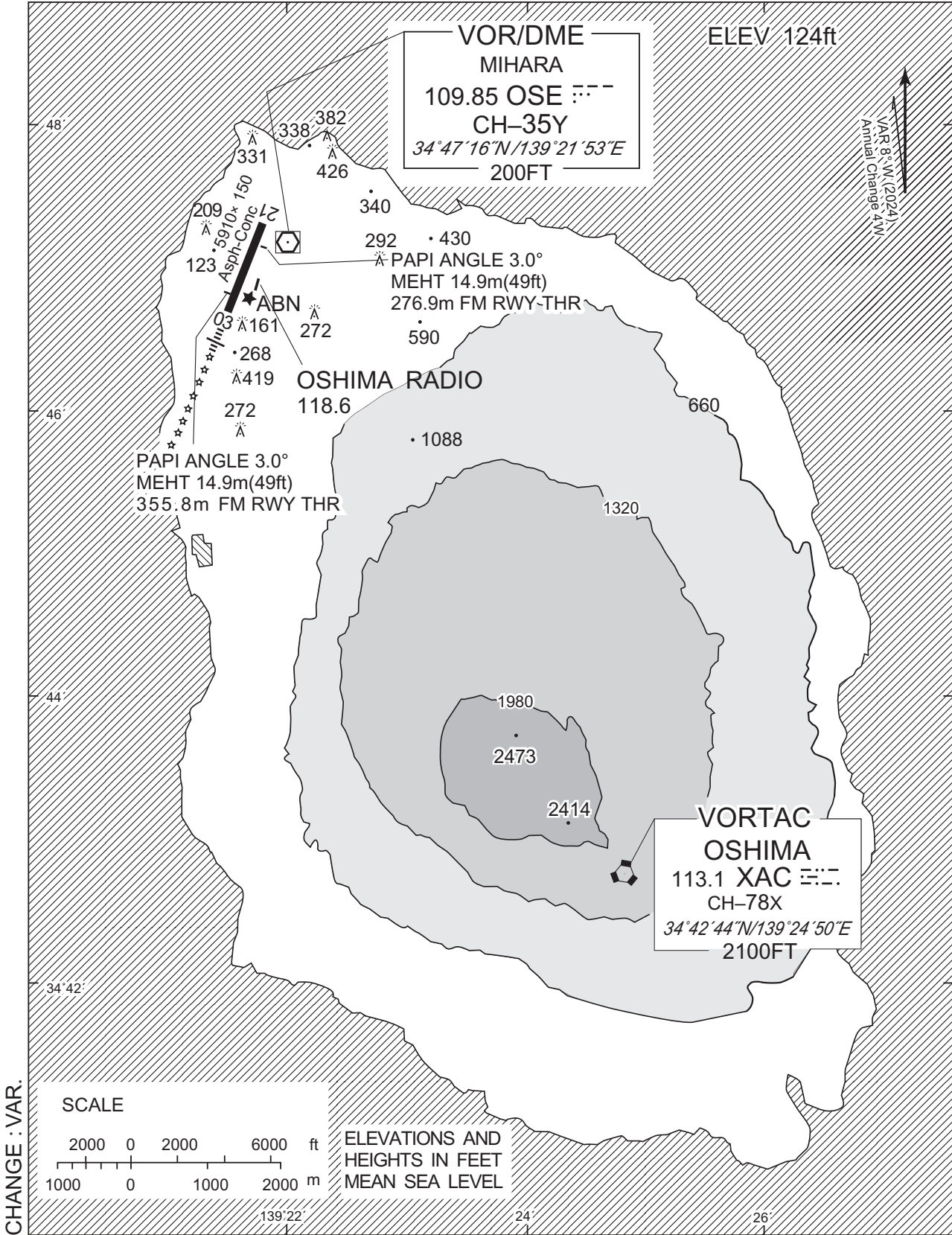

RJTO / OSHIMA

Minimum Vectoring Altitude CHART

VAR 8°W (2019)

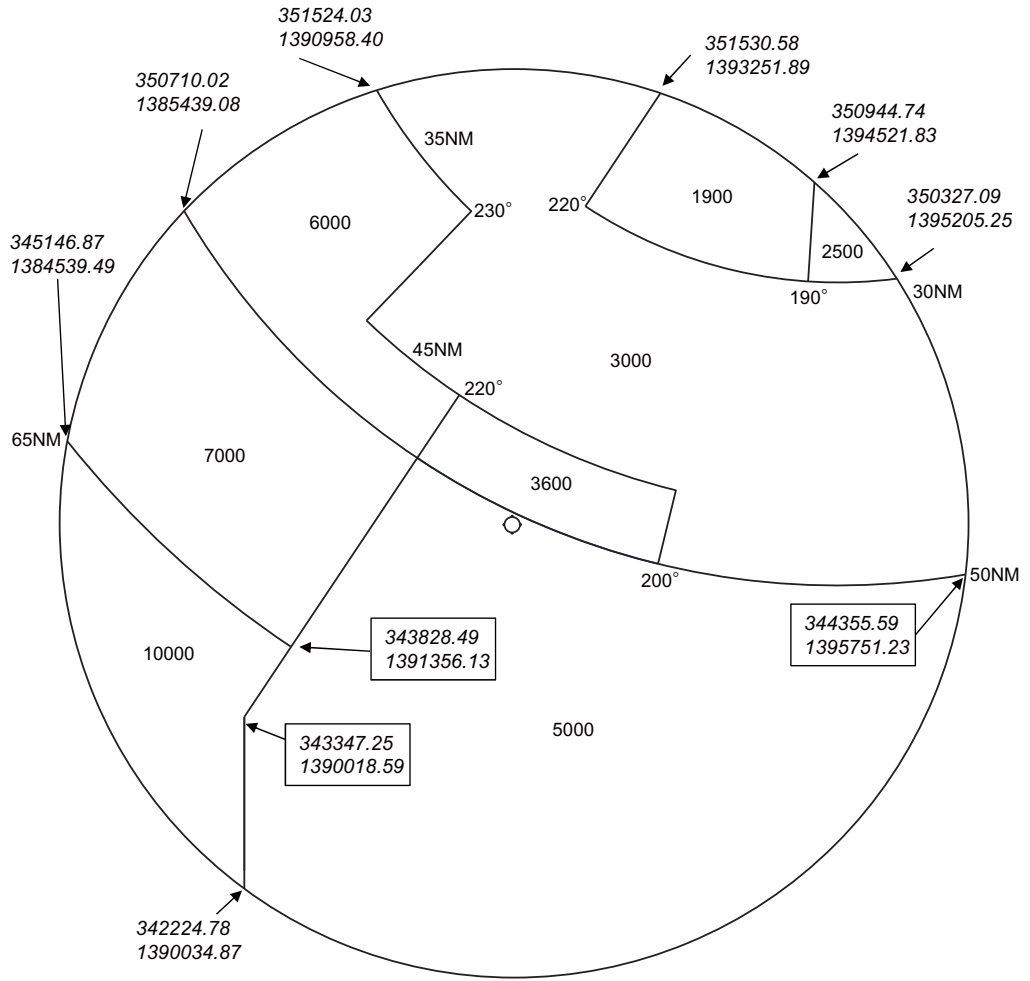

- CENTER : 344655N/1392137E (ARP)
- 344655N/1392137E RADIUS : 30NM
- RADIAL & DISTANCE FM 353312N/1394652E(TOKYO ARP)

CHANGE : VAR.