

**AD 2 AERODROME**

**ROAH AD 2.1 AERODROME LOCATION INDICATOR AND NAME**

**ROAH - NAHA**

**ROAH AD 2.2 AERODROME GEOGRAPHICAL AND ADMINISTRATIVE DATA**

1	ARP coordinates and site at AD	261136N/1273823E 197°/1.86km from RWY 18L THR
2	Direction and distance from (city)	4km (2nm) W of Naha city office
3	Elevation/ Reference temperature	11ft / 32°C (2004-2008)
4	Geoid undulation at AD ELEV PSN	103ft
5	MAG VAR/ Annual change	5°W (2008) / 1.8 ' W
6	AD Administration, address, telephone, telefax, telex, AFS, e-mail and/or Web-site addresses	Naha Airport Office (CAB) 531-3,Ashimine Naha City, Okinawa Pref. AFS:ROAHYFYX Tel:098(857)1101, 098(857)1107(ATS)
7	Types of traffic permitted(IFR/VFR)	IFR/VFR
8	Remarks	Nil

**ROAH AD 2.3 OPERATIONAL HOURS**

1	AD Administration	H24
2	Customs and immigration	Customs: H24 Immigration: 2130-1300
3	Health and sanitation	Quarantine(human): 2300-1300 Quarantine(animal): 2330-1030 Quarantine(plant): 2230-1300
4	AIS Briefing Office	H24
5	ATS Reporting Office(ARO)	Nil
6	MET Briefing Office	H24
7	ATS	H24
8	Fuelling	H24
9	Handling	H24
10	Security	2130 - 1200
11	De-icing	Nil
12	Remarks	Nil

**ROAH AD 2.4 HANDLING SERVICES AND FACILITIES**

1	Cargo-handling facilities	All modern facilities handling weights up to 249,250lb / 113,000kg.
2	Fuel/ oil types	Fuel grades : (CIV) JET A-1, 100/130 (JSDF) JET A-1 PLUS Oil grades : Turbine grade on prior arrangement. All piston grades
3	Fuelling facilities/ capacity	Fuel truck refueling / Ask AD administration
4	De-icing facilities	Nil
5	Hangar space for visiting aircraft	Nil
6	Repair facilities for visiting aircraft	Nil
7	Remarks	Nil

**ROAH AD 2.5 PASSENGER FACILITIES**

1	Hotels	Hotels in the city
2	Restaurants	At airport
3	Transportation	Monorail, buses and taxis
4	Medical facilities	Hospitals in the city
5	Bank and Post Office	At airport
6	Tourist Office	At airport
7	Remarks	Nil

**ROAH AD 2.6 RESCUE AND FIRE FIGHTING SERVICES**

1	AD category for fire fighting	CAT 9
2	Rescue equipment	Chemical fire fighting truck x 3 Water supply truck Lighting power supply truck Emergency medical equipments conveyance truck
3	Capability for removal of disabled aircraft	Ask AD administration
4	Remarks	Nil

**ROAH AD 2.7 SEASONAL AVAILABILITY-CLEARING**

1	Types of clearing equipment	Not applicable
2	Clearance priorities	Not applicable
3	Remarks	Nil

ROAH AD 2.8 APRONS, TAXIWAYS AND CHECK LOCATIONS DATA

1	Apron surface and strength	<p>Surface: Concrete and asphalt Strength: PCN 74/R/B/X/T...NR1, NR2, NR3, NR4, NR5, NR6, NR7 PCN 62/R/B/X/T...WEST apron, TYPHOON EVACUATION apron PCN 48/R/B/X/T...RUNUP AREA PCN 22/F/A/X/T...LIGHT AIRCRAFT spot</p>	
2	Taxiway width, surface and strength	<p>Surface: Concrete and asphalt Strength: PCN 74/R/B/X/T...A1 PCN 66/F/B/X/T...A2, A3 PCN 66/R/B/X/T...A4, A5 PCN 76/R/B/X/T...A6 PCN 102/F/C/X/T...A7 PCN 84/F/B/X/T...A8, A9 PCN 104/F/B/X/T...B PCN 68/R/B/X/T...E1 PCN 56/F/A/X/T...E2 PCN 81/F/A/X/T...E3 PCN 105/F/B/X/T...E4 PCN 81/F/B/X/T...E4C PCN 129/F/B/X/T...E5 PCN 91/F/C/X/T...E6 PCN 111/F/C/X/T...E7 PCN 70/F/C/X/T...E8 PCN 108/F/C/X/T...E8S PCN 80/F/C/X/T...E9 PCN 70/F/A/X/T...E10 PCN 96/F/A/X/T...W1 PCN 94/F/A/X/T...W2 PCN 103/F/A/X/T...W3 PCN 74/F/B/X/T...W3C PCN 64/F/B/X/T...W4 PCN 59/F/A/X/T...W5 PCN 74/R/B/X/T...N1, N2, N3, C1, C2, D1, D2 PCN 94/F/A/X/T...J1, J2, R PCN 92/F/A/X/T...T1, T2 PCN 71/F/C/X/T...T3, T4 PCN 96/F/C/X/T...T5 PCN 63/F/C/X/T...T6, T7 PCN 97/F/A/X/T...T8, T9 PCN 92/F/A/X/T...C</p> <p>Width: 34m ...E2, E6, E8S, E9, W4 30m ...E1, E3, E4, E4C, E5, E7, E8, W2, W3, W3C, J1, J2, C, T1 - T9 28.5m...E10 26.5m...B, W1, W5 44.9m...R 23m ...Other TWY</p>	
3	ACL and elevation	Not available	
4	VOR checkpoints	Not available	

5	INS checkpoints	<p>Spot NR</p> <p>11 : 261210.16N/1273900.76E  12 : 261210.09N/1273858.76E  12M : 261209.66N/1273858.68E  13 : 261210.01N/1273856.78E  13M : 261209.58N/1273856.59E  14 : 261209.94N/1273854.80E  15 : 261208.84N/1273854.34E</p> <p>21 : 261215.84N/1273900.38E  22 : 261216.31N/1273858.00E  23 : 261216.36N/1273855.70E  24 : 261217.81N/1273854.77E  25 : 261219.25N/1273855.50E  26 : 261219.51N/1273857.85E  27 : 261219.95N/1273900.35E</p> <p>31 : 261225.90N/1273859.91E  32 : 261226.46N/1273857.58E  33 : 261226.45N/1273855.26E  34 : 261227.87N/1273854.30E  35 : 261229.24N/1273855.08E</p> <p>36 : 261229.72N/1273857.04E  37 : 261231.50N/1273859.89E</p> <p>41 : 261234.36N/1273859.19E  42 : 261236.27N/1273859.72E  43R : 261238.15N/1273859.65E  43 : 261238.72N/1273859.61E  43L : 261239.58N/1273858.62E  44R : 261241.07N/1273859.52E  44 : 261241.50N/1273859.55E  44L : 261242.50N/1273858.48E  45C : 261243.35N/1273859.18E  45 : 261243.97N/1273858.60E  46C : 261245.16N/1273859.10E  46 : 261245.43N/1273858.53E</p> <p>51R : 261247.61N/1273857.57E  51 : 261248.48N/1273858.37E  51L : 261249.07N/1273857.51E  52 : 261250.52N/1273857.42E  57D : 261254.40N/1273858.52E</p> <p>61 : 261255.39N/1273900.89E  62 : 261256.57N/1273902.92E  63 : 261257.30N/1273904.91E  63E : 261257.53N/1273905.52E  64 : 261258.02N/1273906.89E  65 : 261258.74N/1273908.89E  65E : 261258.95N/1273909.45E  66 : 261259.46N/1273910.88E</p> <p>71 : 261235.71N/1273853.69E  72 : 261238.35N/1273853.71E  73 : 261240.74N/1273853.60E  74 : 261242.81N/1273853.51E</p> <p>98 : 261141.92N/1273830.97E  99 : 261143.23N/1273830.90E</p>	<p>100L : 261144.55N/1273830.84E  100 : 261145.33N/1273830.94E  100R : 261145.86N/1273830.78E  101 : 261147.83N/1273832.26E  102 : 261149.54N/1273832.16E  103 : 261151.00N/1273832.09E  104 : 261153.07N/1273833.10E  105 : 261154.27N/1273832.70E  106 : 261156.66N/1273832.67E  H : 261158.60N/1273831.87E  107 : 261201.28N/1273831.75E</p>
6	Remarks	Nil	

**ROAH AD 2.9 SURFACE MOVEMENT GUIDANCE AND CONTROL SYSTEM AND MARKINGS**

1	Use of aircraft stand ID signs, TWY guide lines and Visual docking/ parking guidance system of aircraft stands	<ul style="list-style-type: none"> <li>• C1, C2, D1, D2, N1, N2, N3 are designated as aircraft stand taxilane intended to provide access to aircraft stands at NR1, NR2, NR3, NR4, NR5, NR6 and NR7 apron.</li> <li>• Aircraft stand identification sign : SPOT NR21 - 27, 31 - 37, 41 - 44</li> </ul>
2	RWY and TWY markings and LGT	<p>RWY : RWY18L/36R, 18R/36L (Marking) RWY designation, RWY CL, RWY THR, Aiming point, TDZ, RWY side stripe (LGT) REDL, RCLL, RTHL, RENL, RTZL, WBAR, Takeoff Hold Lights(RWY status LGT)(RWY 18L/36R, see attached chart)</p> <p>TWY: All TWY (Marking) TWY CL, RWY HLDG PSN, TWY side stripe, Mandatory instruction (LGT) TWY edge LGT, Taxiing guidance sign</p> <p>TWY: E1 - E10, W1 - W5, A1 - A9, B, J1, J2, T1 - T9, C, R, ACFT stand taxilane C1, C2, D1, D2, N1 - N3 (LGT) TWY CL LGT</p> <p>TWY: E1 - E10, W1 - W5, T1 - T9 (LGT) RWY guard LGT</p> <p>TWY: E1, E2, E3, E4, E4C, E5, E6, E7, E8, E9, A2 - A4, B, J1, J2, T3 - T7 (Marking) Intermediate HLDG PSN (See Figure "Marking AIDs and Parkings Area (East side)")</p> <p>TWY: A8, T1, T2 (Marking) Intermediate HLDG PSN (LGT) Intermediate HLDG PSN LGT</p> <p>TWY: E1, E2, E3, E4C, E6, E8S, E9, E10, W1, W2, W3C, W4, W5 (LGT) RWY Entrance LGT (RWY status LGT) (See attached chart)</p> <p>TWY: T3, T4, T6, T7 (LGT) Rapid exit TWY indicator LGT</p>
3	Stop bars	<p>Stop bar LGT: T1 - T9 Stop bar lights Operations</p> <ol style="list-style-type: none"> <li>1) Stop bar lights are installed at each taxi holding position associated with Runway 18R/36L.</li> <li>2) Stop bar lights will be operated when the visibility or the lowest RVR of the runway 18R/36L is at or less than 600m.</li> <li>3) Stop bar lights on taxiways T1, T2, T8 and T9 are controlled individually by ATC.</li> <li>4) Stop bar lights on taxiways T3 THRU T7 are not controlled individually by ATC.</li> <li>5) During the period stop bar lights operated, taxiways T3 THRU T7 are not available for departure aircraft.</li> </ol>
4	Remarks	<p>(Marking) Overrun area, Stop line(N2, N3) (LGT) Apron flood LGT</p>

MARKING AIDS  
(RWY18R/36L)

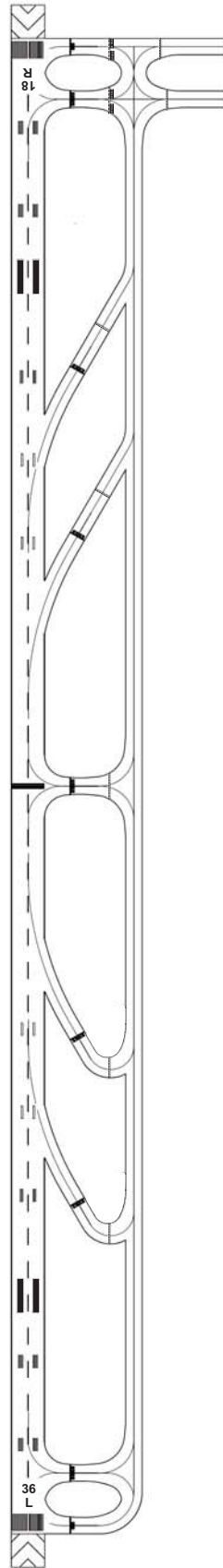

MARKING AIDS  
(RWY18L/36R)

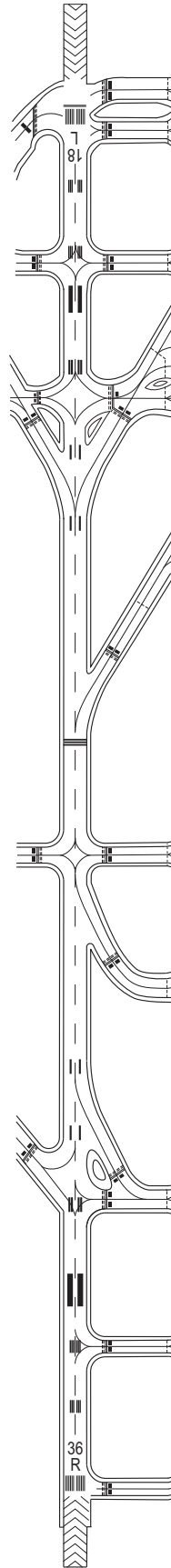

Marking AIDs and Parkings Area (West side)

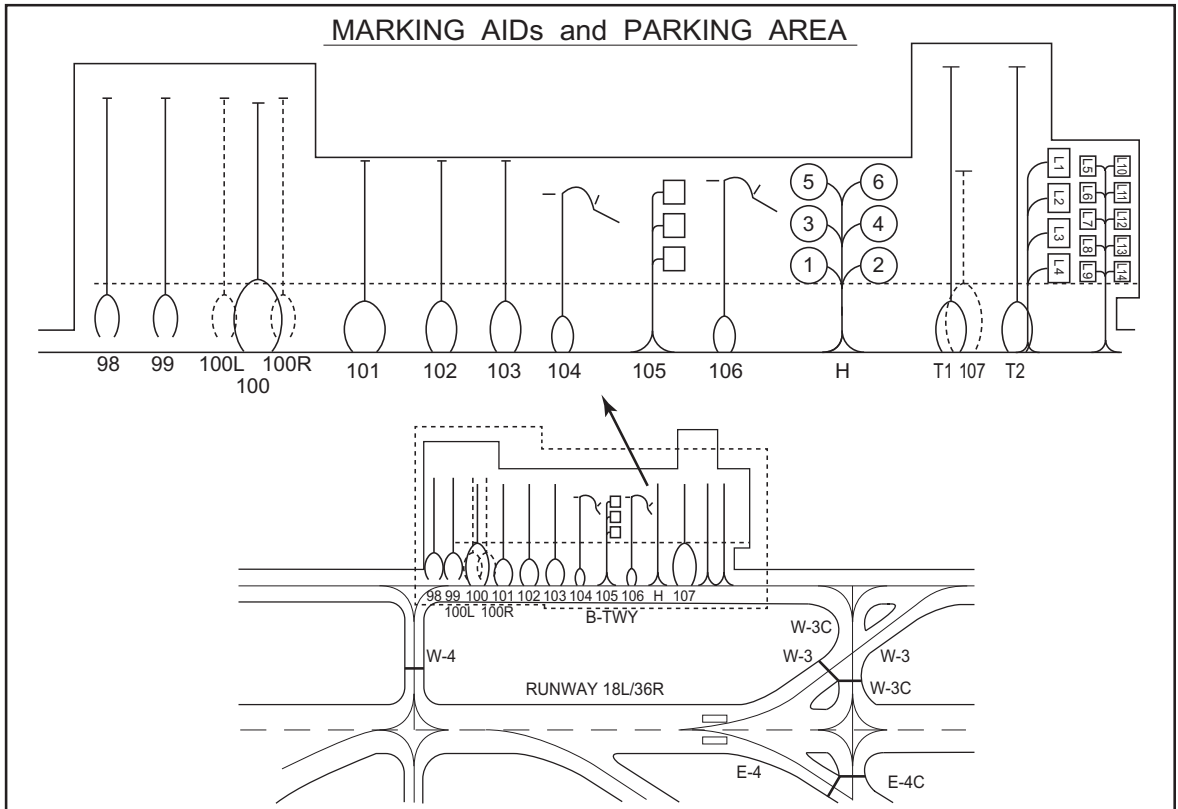

Marking AIDs and Parkings Area (East side)

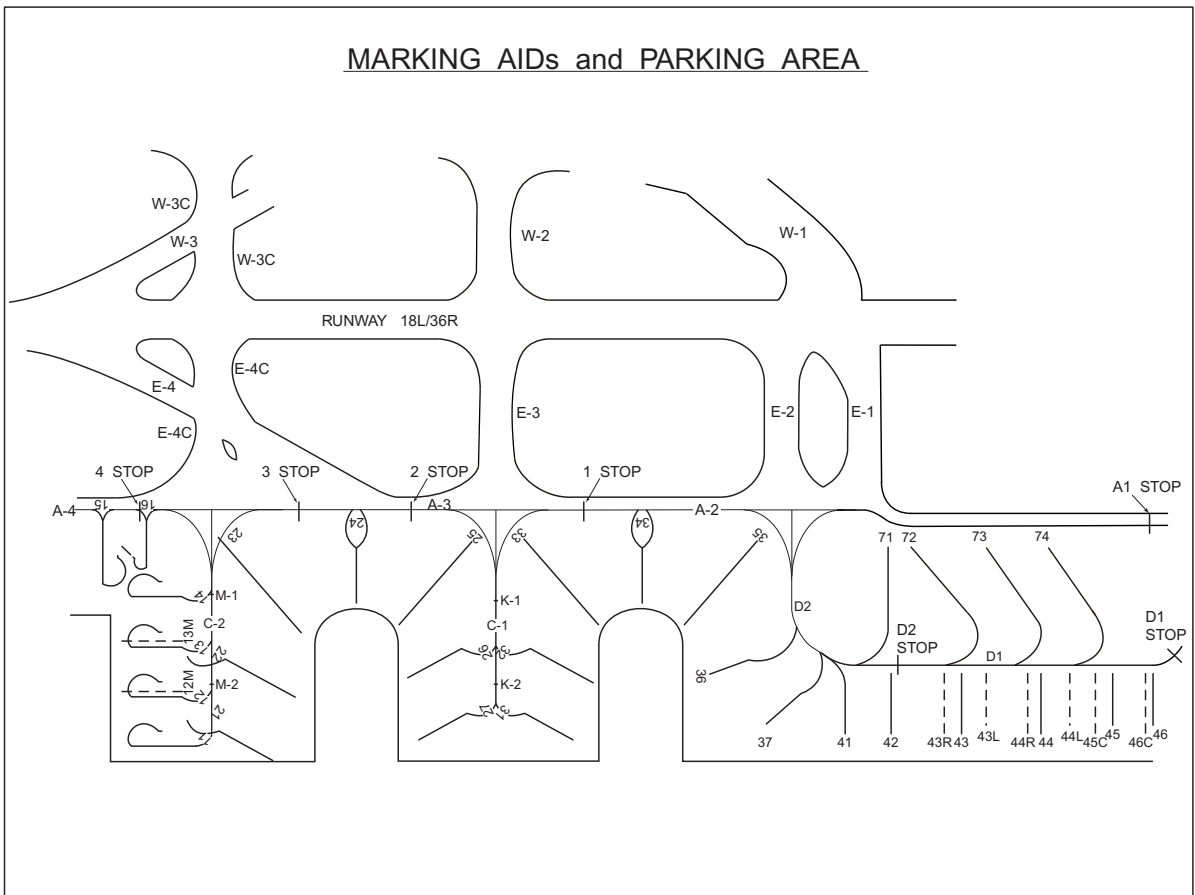

### Intermediate Holding Position Marking and Intermediate Holding Position Lights

The Intermediate Holding Position Marking indicates the position where aircraft is to hold to prevent collision with other aircraft on the taxiway. The Intermediate Holding Position Lights are collocated with the Intermediate Holding Position Marking and synchronized with the taxiway center line lights. The Intermediate Holding Position Lights consist of 5 yellow lights and the Intermediate Holding Position Marking is a single broken line as illustrated in the figure below;

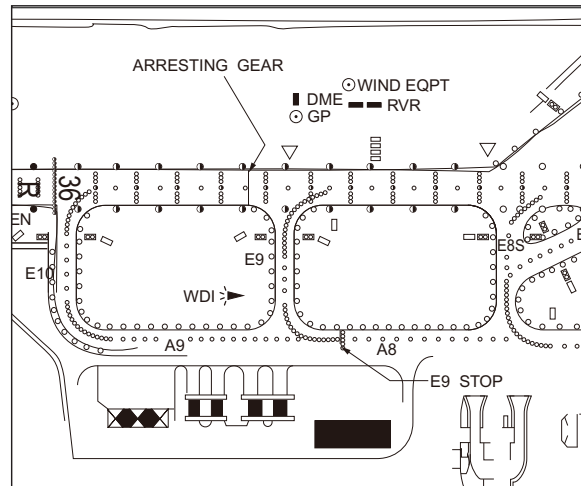
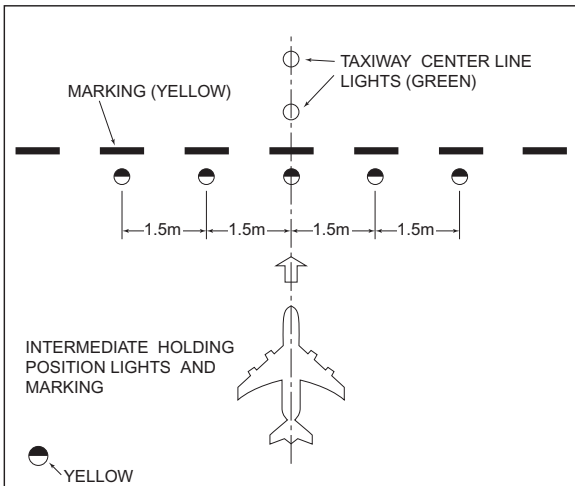

### GP HOLD LINE

The "GP HOLD LINE" is installed on TWY T1 AND T2 , consists of Intermediate holding position lights and marking. (see below figure, and AD2.24-ADC-1 AD CHART) REF AD2.20.2.2.1 for taxiing procedure on the "GP HOLD LINE".

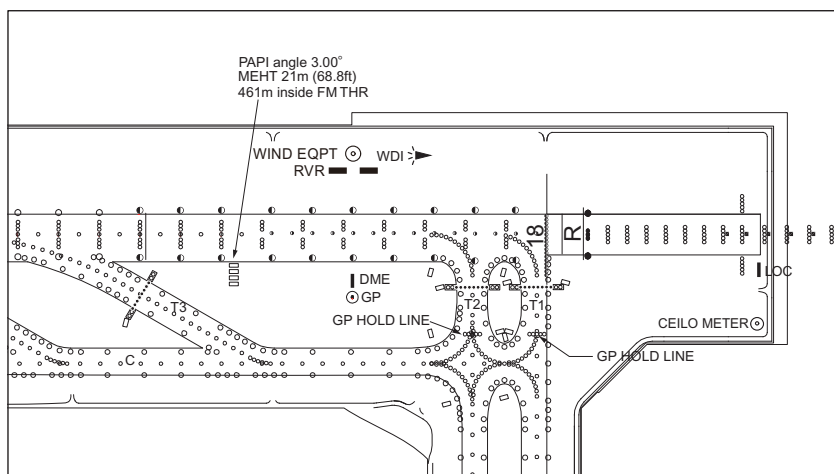



Runway Entrance Lights(REL) and Takeoff Hold Lights(THL)

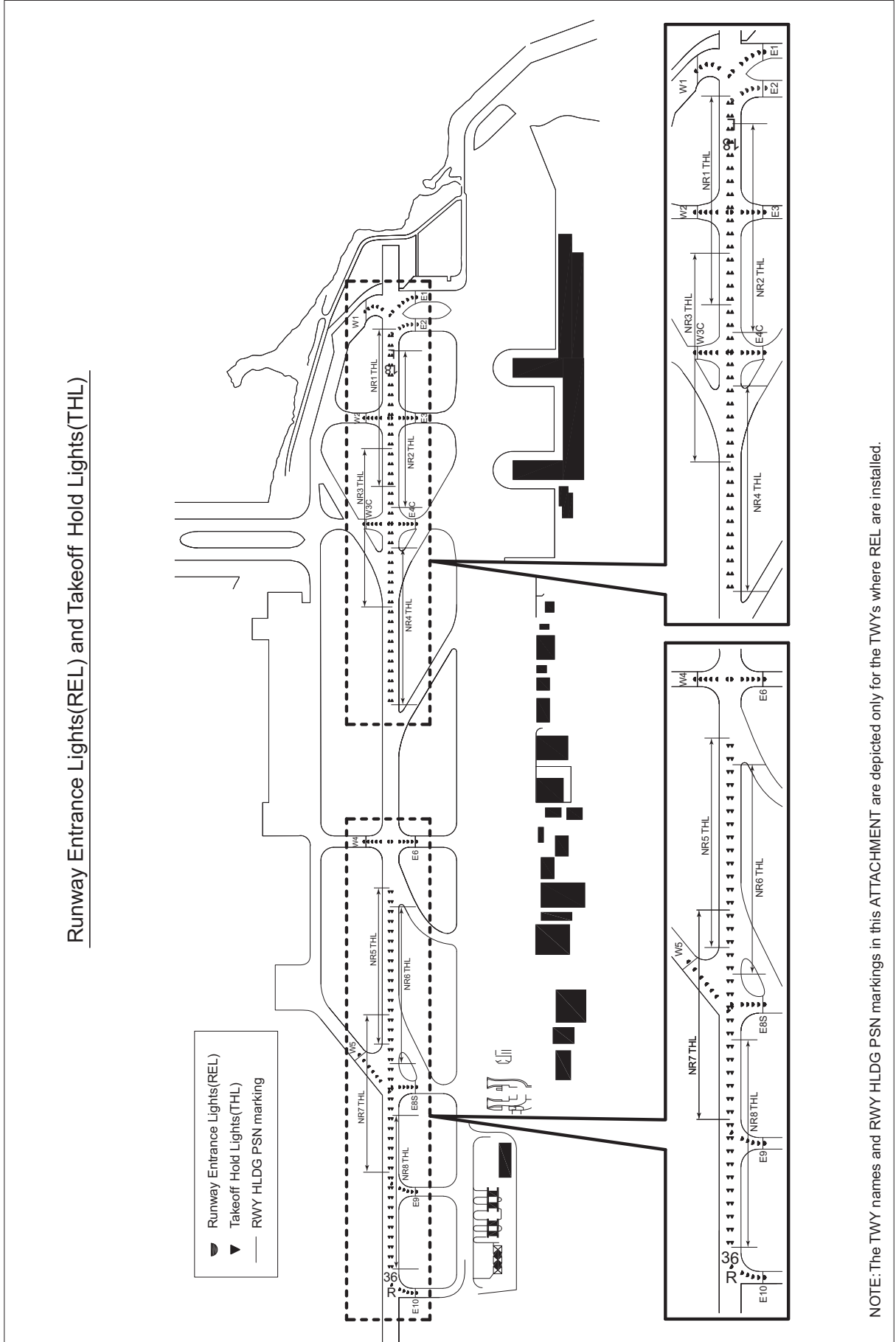

## ROAH AD 2.10 AERODROME OBSTACLES

■ In Area2 See Obstacle data

■ In Area3 To be developed

## ROAH AD 2.11 METEOROLOGICAL INFORMATION PROVIDED

1	Associated MET Office	NAHA
2	Hours of service MET Office outside hours	H24
3	Office responsible for TAF preparation Periods of validity	NAHA 30 Hours
4	Trend forecast Interval of issuance	Nil
5	Briefing/consultation provided	P,Ja,En
6	Flight documentation Language(s) used	C En
7	Charts and other information available for briefing or consultation	S <sub>6</sub> , U <sub>85</sub> , U <sub>7</sub> , U <sub>5</sub> , U <sub>3</sub> , U <sub>25</sub> , U <sub>2/T<sub>r</sub></sub> , P <sub>S</sub> , P <sub>5</sub> , P <sub>3</sub> , P <sub>25</sub> , P <sub>SWE</sub> , P <sub>SWF</sub> , P <sub>SWG</sub> , P <sub>SWI</sub> , P <sub>SWM</sub> , P <sub>SW(domestic)</sub> , E, C, W <sub>E</sub> , W <sub>F</sub> , W <sub>G</sub> , W <sub>I</sub> , W, N
8	Supplementary equipment available for providing information	Doppler Radar for Airport Weather (See attached chart)
9	ATS units provided with information	TWR, GCA, APP, ATIS
10	Additional information(limitation of service, etc.)	Nil

**Airspace for the advisory service concerning low level wind shear (RWY18L)**

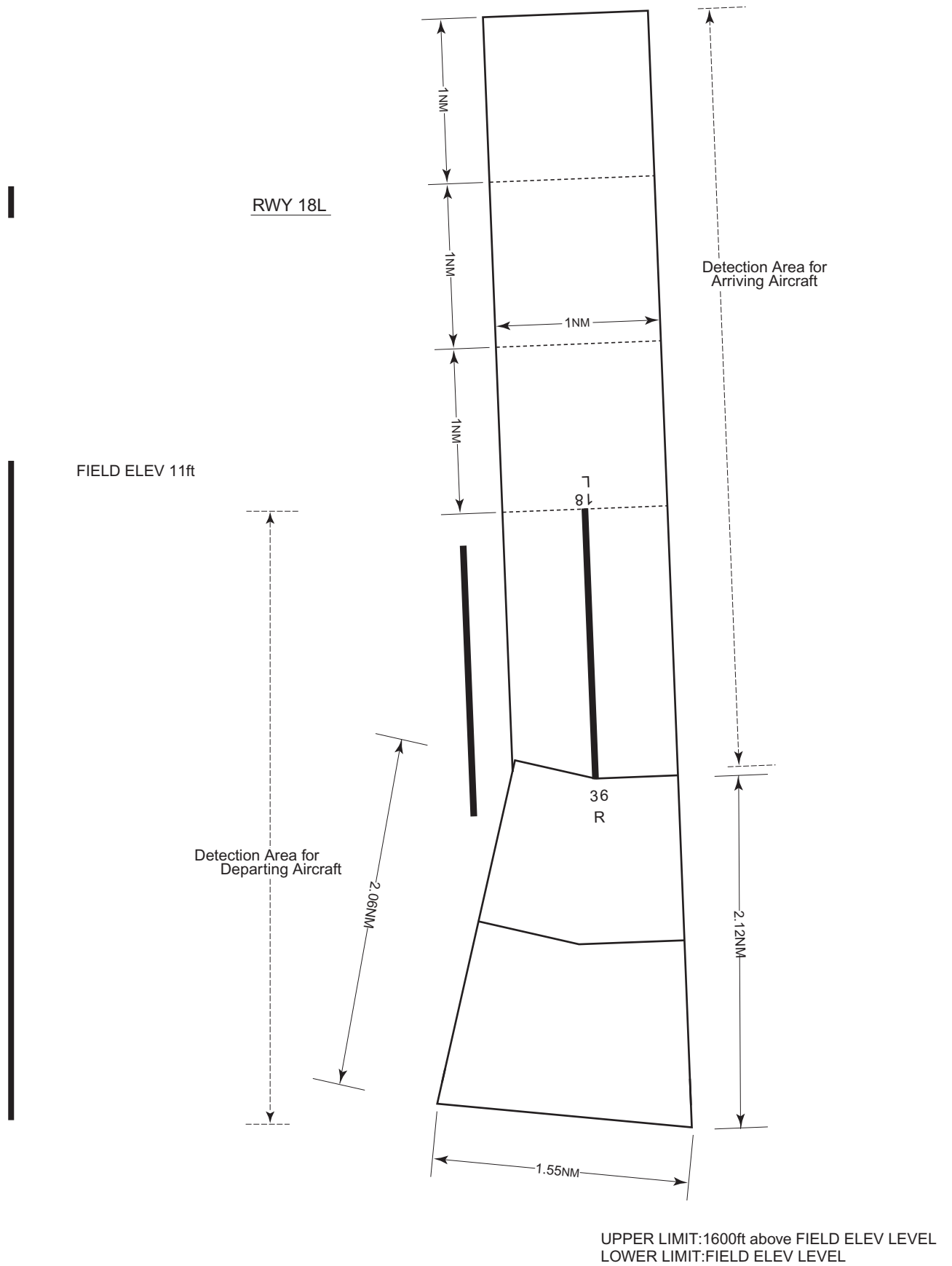

**Airspace for the advisory service concerning low level wind shear (RWY18R)**

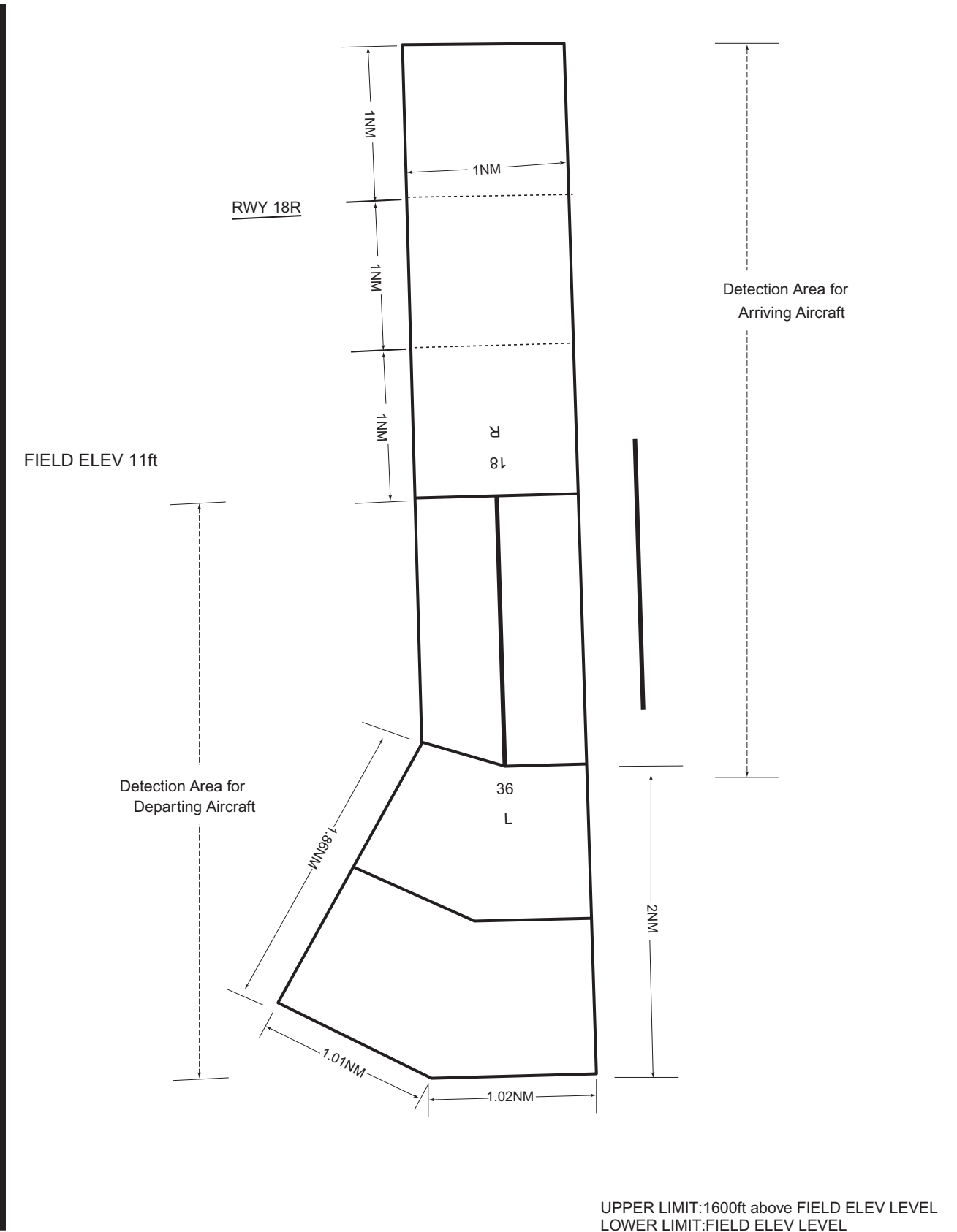

**Airspace for the advisory service concerning low level wind shear (RWY36R)**

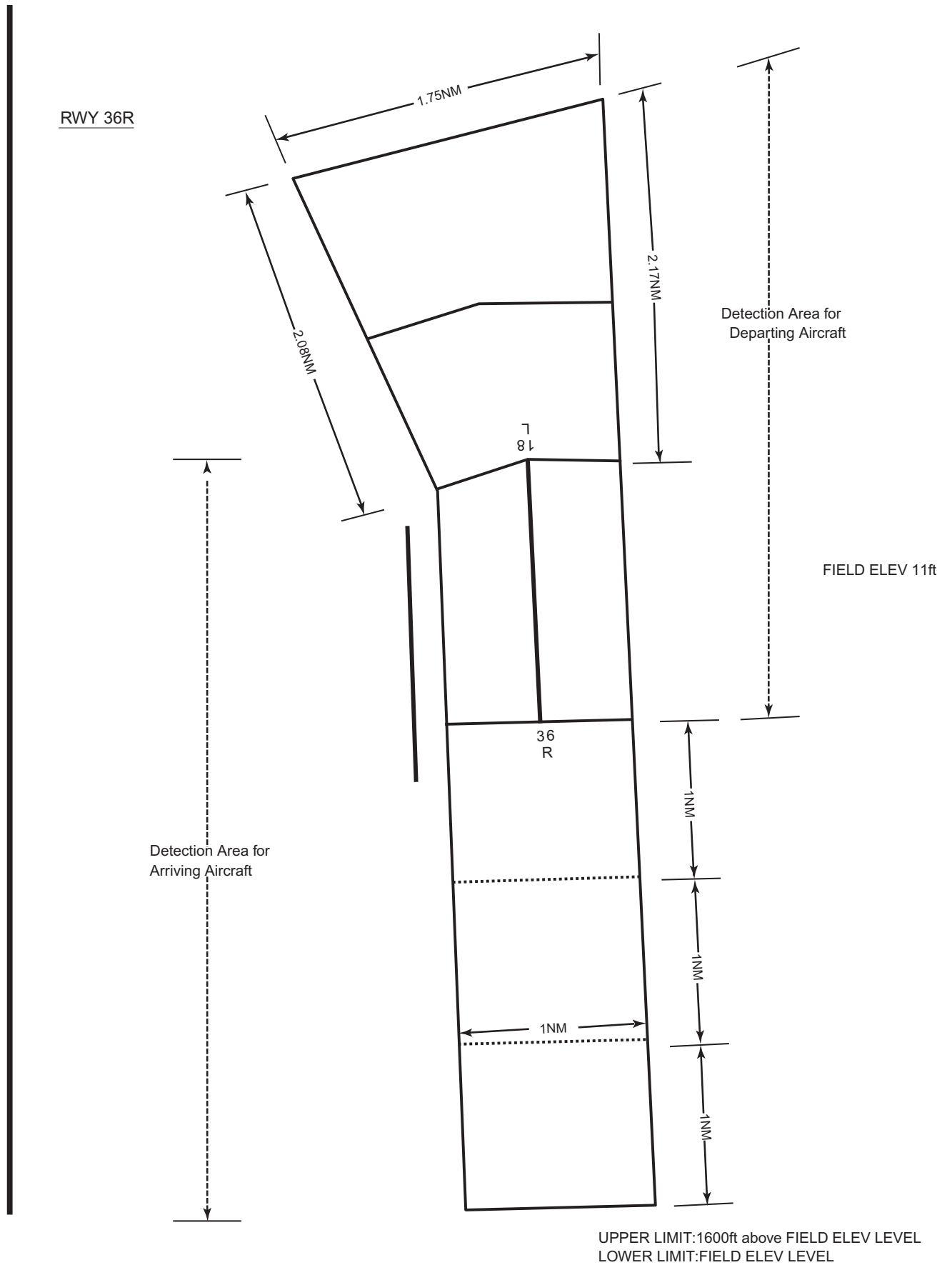

**Airspace for the advisory service concerning low level wind shear (RWY36L)**

RWY 36L

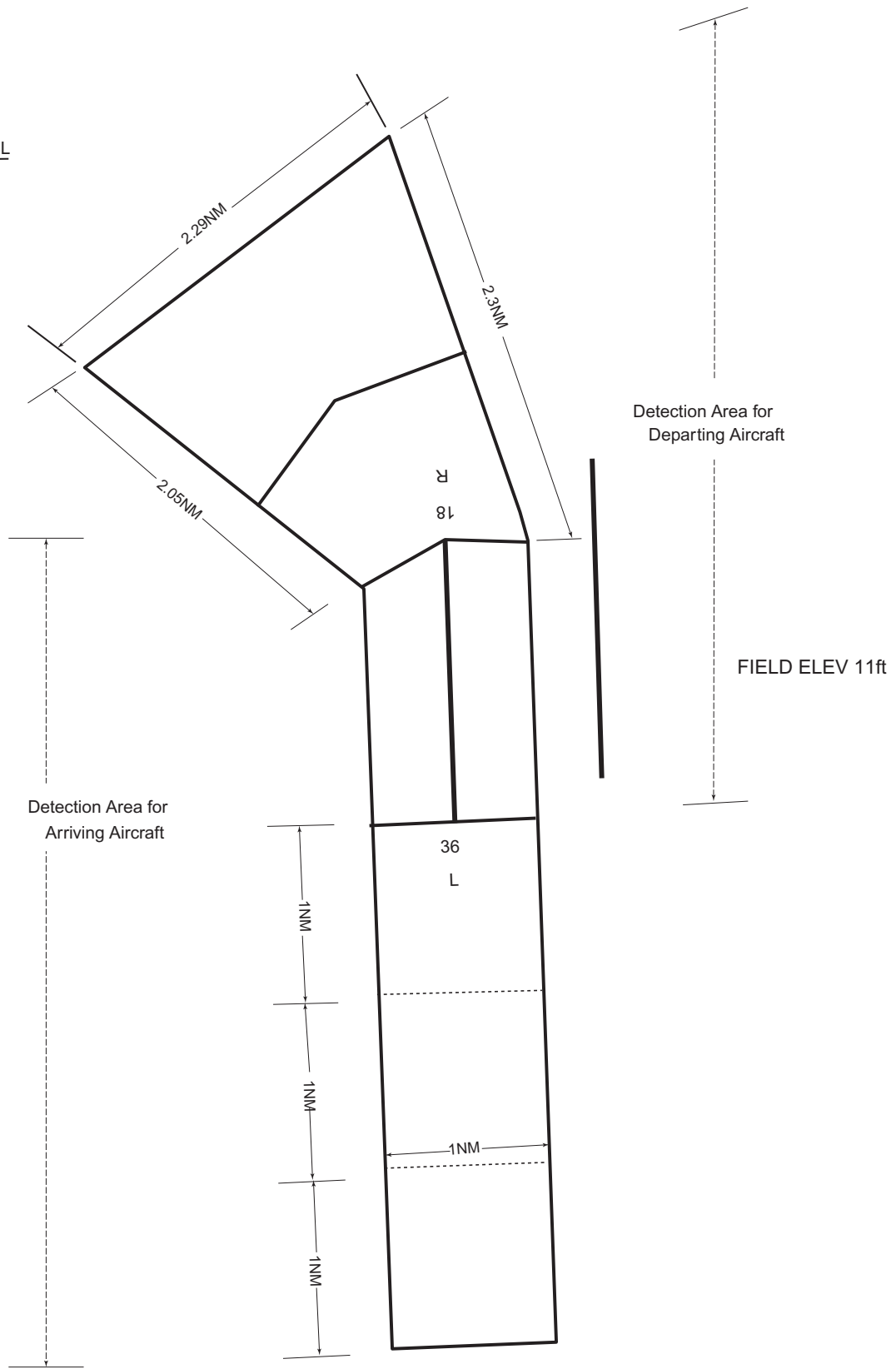

UPPER LIMIT:1600ft above FIELD ELEV LEVEL  
LOWER LIMIT:FIELD ELEV LEVEL

**ROAH AD 2.12 RUNWAY PHYSICAL CHARACTERISTICS**

Designations RWY NR	TRUE BRG	Dimensions of RWY(M)	Strength(PCN) and surface of RWY	THR coordinates THR geoid undulation	THR elevation and highest elevation of TDZ of precision APP RWY
1	2	3	4	5	6
18L	177.30°	3000 x 45	PCN 92/F/A/X/T Asphalt	261233.63N/ 1273842.84E 104FT	THR ELEV: 10.9FT TDZ ELEV: 11.5FT
36R	357.30°	3000 x 45	PCN 92/F/A/X/T Asphalt	261056.24N/ 1273847.41E 103FT	THR ELEV: 9.0FT TDZ ELEV: 10.8FT
18R	177.30°	2700 x 60	PCN 78/F/A/X/T Asphalt	261211.00N/ 1273756.64E 103FT	THR ELEV: 16.3FT TDZ ELEV: 13.8FT
36L	357.30°	2700 x 60	PCN 78/F/A/X/T Asphalt	261043.34N/ 1273800.77E 103FT	THR ELEV: 14.0FT TDZ ELEV: 14.0FT
Slope of RWY	Strip Dimensions(M)	RESA (Overrun) Dimensions (M)	Remarks		
7	10	11	14		
See attached chart	3120 x 300 3120 x 300	90x(MNM:195 MAX:300)* 150x(MNM:190 MAX:290)* *For detail, ask airport administrator	RWY grooving: 3000 x 30m		
See attached chart	2820 x 300 2820 x 300	240x300 240x300	RWY grooving: 2700 x 40m		
Slope of RWY					
<p><b>RWY36R</b> <span style="float: right;"><b>RWY18L</b></span></p> <p>90 91 100 103 108 109 100 118 119 116 106 112 115 114 109</p> <p>0.003% 0.20% 0.04% 0.05% 0.01% 0.16% 0.25% 0.03% 0.05% 0.18% 0.14% 0.02% 0.01% 0.06%</p> <p>0 275 420 600 900 1180 1355 1570 1700 1900 2055 2190 2560 2720 3000</p> <p><b>RWY36L</b> <span style="float: right;"><b>RWY18R</b></span></p> <p>140 140 123 123 163</p> <p>LEVEL 0.25% 0.50%</p> <p>0 260 460 2460 2700</p>					

## ROAH AD 2.13 DECLARED DISTANCES

RWY Designator	TORA (m)	TODA (m)	ASDA (m)	LDA (m)	Remarks
1	2	3	4	5	6
18L	3000	3000	3000	3000	9843ft
TWY: E2	2904	2904	2904		9528ft
TWY: E3, W2	2604	2604	2604		8544ft
TWY: E4C, W3C	2294	2294	2294		7527ft
TWY: E4	2018	2018	2018		6621ft
TWY: W3	1999	1999	1999		6559ft
TWY: E5	1512	1512	1512		4961ft
TWY: E6, W4	1321	1321	1321		4334ft
TWY: E8S, W5	606	606	606		1988ft
TWY: E9	258	258	258		846ft
36R	3000	3000	3000	3000	9843ft
TWY: E9	2628	2628	2628		8622ft
TWY: E8S	2310	2310	2310		7579ft
TWY: W5	2257	2257	2257		7405ft
TWY: E8	2052	2052	2052		6733ft
TWY: E7, E6, W4	1558	1558	1558		5112ft
TWY: E4C, W3C	606	606	606		1988ft
TWY: E3, E2	296	296	296		971ft
18R	2700	2700	2700	2700	8859ft
TWY: T2	2530	2530	2530		8301ft
TWY: T3	1800	1800	1800		5906ft
TWY: T4	1500	1500	1500		4922ft
TWY: T5	1290	1290	1290		4232ft
36L	2700	2700	2700	2700	8859ft
TWY: T8	2530	2530	2530		8301ft
TWY: T7	1800	1800	1800		5906ft
TWY: T6	1500	1500	1500		4922ft
TWY: T5	1290	1290	1290		4232ft

誘導路の TORA, TODA 及び ASDA は、誘導路中心線と滑走路中心線の交点から滑走路末端までの距離を示す。  
(TORA, TODA and ASDA for TWY indicate distances BTN the point where TWY CL meets RWY CL and RWY THR.)



**ROAH AD 2.14 APPROACH AND RUNWAY LIGHTING**

RWY Designator	APCH LGT type LEN INTST	RTHL Color WBAR	PAPI (VASIS) Angle DIST FM THR MEHT	RTZL LEN	RCLL LEN Spacing Color INTST	REDL LEN Spacing Color INTST	RENL Color WBAR	STWL LEN Color
1	2	3	4	5	6	7	8	9
18L	PALS 480m LIH	Green Green	PAPI 3.00°LEFT 453m 70ft	900m	3000m 30m Coded color (White/Red) LIH	3000m 60m Coded color (White/Yellow) LIH	Red	Nil (*1)
36R	PALS (CAT I) 900m LIH	Green Green	PAPI 3.00°LEFT 447m 70ft	900m	3000m 30m Coded color (White/Red) LIH	3000m 60m Coded color (White/Yellow) LIH	Red	Nil (*2)
18R	PALS (CAT I) 900m LIH	Green Green	PAPI 3.00°LEFT 461m 68.8ft	900m	2700m 30m Coded color (White/Red) LIH	2700m 60m Coded color (White/Yellow) LIH	Red	Nil (*3)
36L	PALS (CAT I) 900m LIH	Green Green	PAPI 3.00°LEFT 436m 67.2ft	900m	2700m 30m Coded color (White/Red) LIH	2700m 60m Coded color (White/Yellow) LIH	Red	Nil (*3)
Remarks								
10								
Overrun area edge LGT(LEN:150m Color:Red) (*1) Overrun area edge LGT(LEN:192m Color:Red) (*2) Overrun area edge LGT(LEN:60m Color:Red) (*3)								

**ROAH AD 2.15 OTHER LIGHTING, SECONDARY POWER SUPPLY**

1	ABN/IBN location, characteristics and hours of operation	ABN: 261248N/1273908E, White/Green EV4.3sec, HO
2	LDI location and LGT Anemometer location and LGT	LDI: Nil Anemometer : RWY18L: 295m from RWY18L THR, lighted RWY36R: 432m from RWY36R THR, lighted RWY18R: 300m from RWY18R THR, lighted RWY36L: 325m from RWY36L THR, lighted
3	TWY edge and center line lighting	TWY edge and center line lights installed, see AD2.9
4	Secondary power supply / switch-over time	Within 1 sec : REDL, RENL, RTHL, WBAR, RCLL, Overrun area edge LGT, Stop bar LGT, Runway Entrance Lights  Within 15 sec : Other LGT
5	Remarks	Nil

**ROAH AD 2.16 HELICOPTER LANDING AREA**

Nil
-----

**ROAH AD 2.17 ATS AIRSPACE**

Designation and lateral limits	Vertical limits (ft)	Airspace classification	ATS unit call sign Language	Remarks
1	2	3	4	6
Naha CTR	(1) Area within a radius of 5nm of NAHA ARP (2612N/12738E), in the west side of a line extending from 261429N1274125E on 052°56'T and 125°31'T  ----- 2000 (EXC 2000)	D	Naha Tower En	
	(2) Area within a radius of 19nm of NHC VORTAC, in the west side of NHC 015R and in the north side of NHC 315R, excluding area(1) and area within a radius of 5nm of Kadena ARP(2621N/12746E).  ----- 700 (EXC 700)	B	Naha APP/DEP Naha RADAR Naha ARR En	
Naha PCA	See attached chart	B	Naha APP/DEP Naha RADAR Naha ARR Kadena ARR En	
Naha ACA	See attached chart	E	Naha APP/DEP Naha RADAR Naha ARR Kadena ARR En	
Naha TCA	See attached chart	E	Naha TCA En	

那覇特別管制区  
Naha Positive Control Area (Class B)

NAME	LATERAL LIMITS	UPPER LIMIT (AMSL) LOWER LIMIT (AMSL) M(ft)	UNIT PROVIDING SERVICE	REMARKS
1	2	3	4	5
那覇 Naha	下記に示される区域 The area shown below		<p>1. 那覇VORTACのR050及びR230の線の北西で飛行する航空機: Naha APP 119.1MHz/335.8MHz</p> <p>1. Aircraft operating northwest of the Naha VORTAC 050/230 radials: Naha APP 119.1MHz/335.8MHz</p> <p>2. 那覇VORTACのR050及びR230の線の南東で飛行する航空機: Naha APP 126.5MHz/258.3MHz</p> <p>2. Aircraft operating southeast of the Naha VORTAC 050/230 radials: Naha APP 126.5MHz/258.3MHz</p>	<p>当該空域を飛行しようとする航空機は、入域前に那覇アプローチに連絡し、コールサイン、現在位置、高度及び意図を通報し指示を受けること。 (当該空域と重複する那覇管制圏を飛行しようとする航空機に対しては、那覇アプローチから当該管制圏内の飛行に係る指示が発出される。)</p> <p>All aircrafts requiring transit of Naha Positive Control Area must call Naha Approach prior to the point of entry to provide aircraft identification, position, altitude and intention. (Pilots intending to fly in the portion of the overlapping Naha CTR with Naha PCA should maintain contact with Naha Approach for ATC clearances and instructions.)</p>

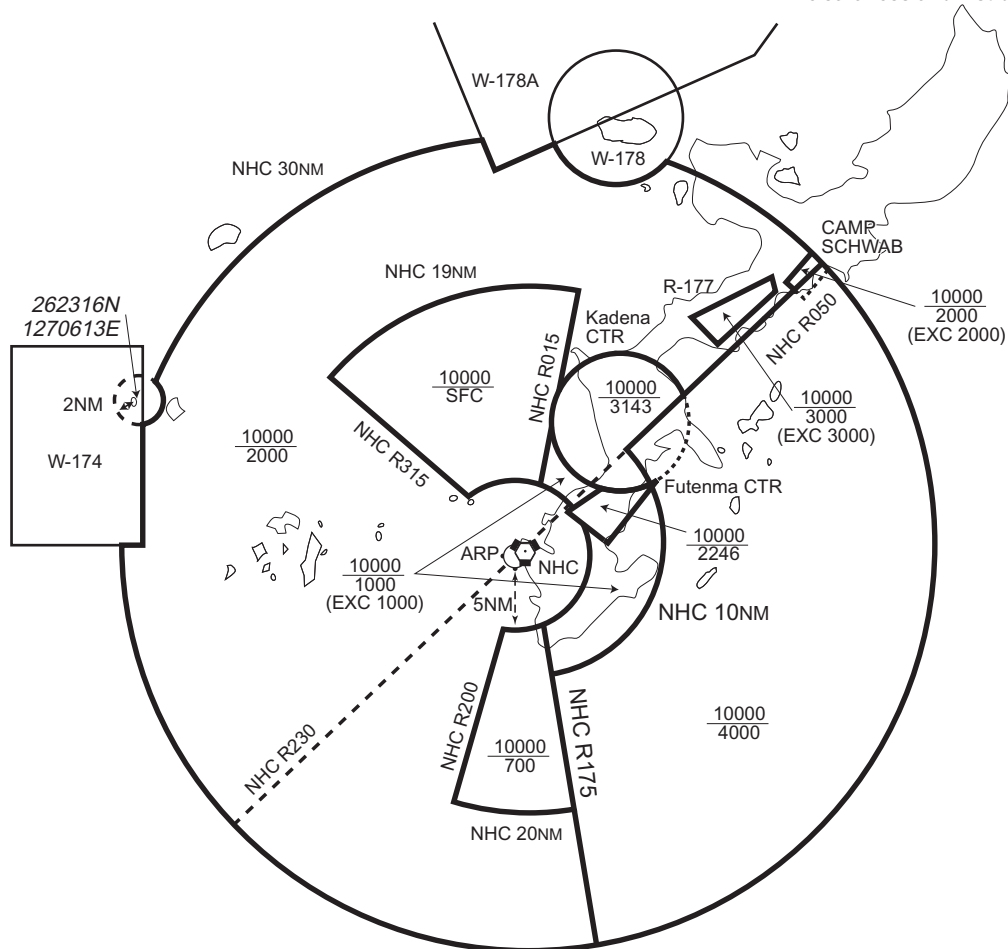

那覇進入管制区  
Naha Approach Control Area

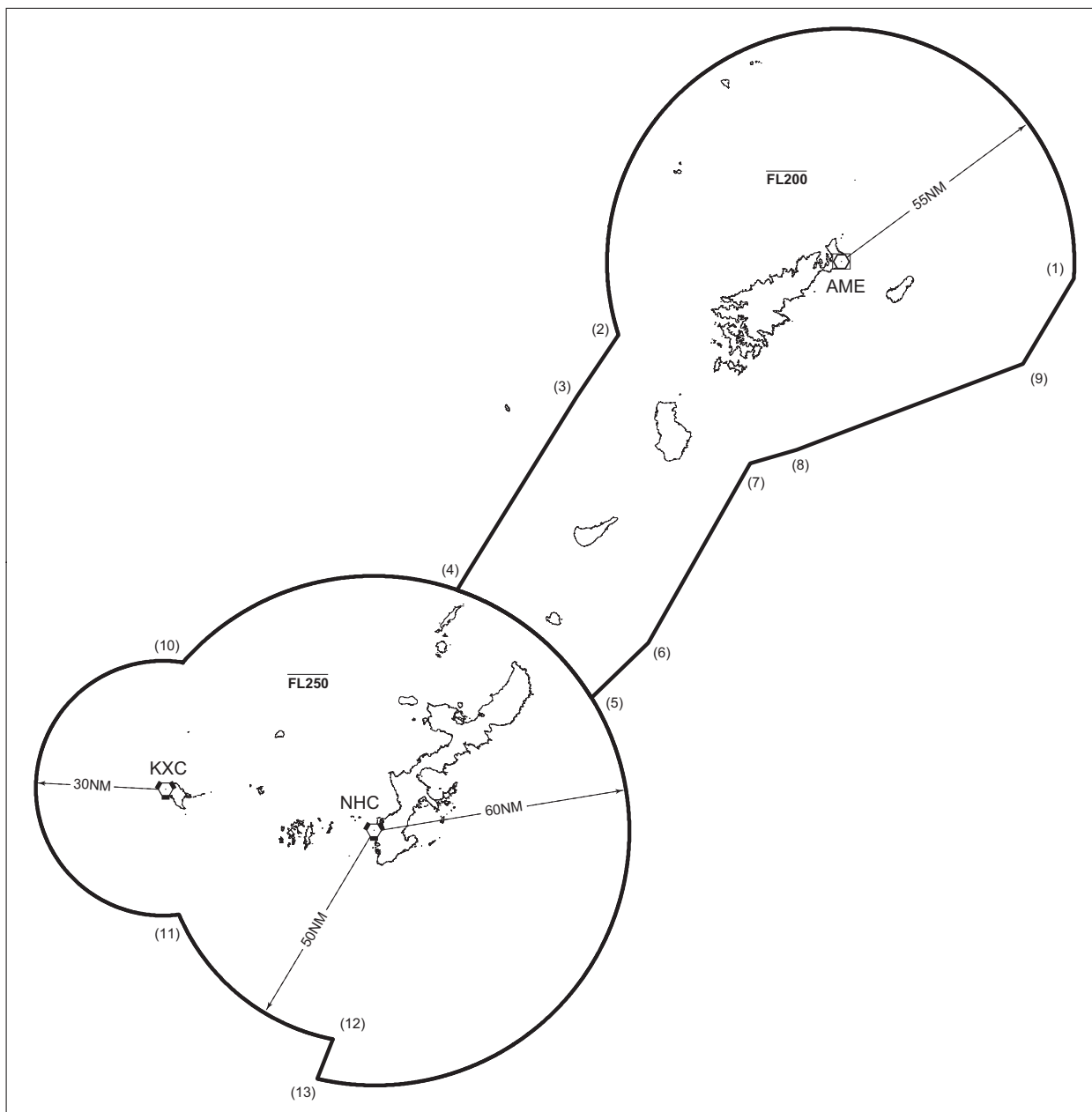

Point list

- |                      |                       |
|----------------------|-----------------------|
| (1) 282121N/1304450E | (8) 274201N/1293022E  |
| (2) 280927N/1284315E | (9) 280130N/1303045E  |
| (3) 275507N/1283205E | (10) 265159N/1264807E |
| (4) 270928N/1280014E | (11) 255229N/1264740E |
| (5) 264352N/1283540E | (12) 252316N/1272802E |
| (6) 265648N/1285042E | (13) 251400N/1272404E |
| (7) 273900N/1291757E |                       |

那覇ターミナルコントロールエリア  
Naha Terminal Control Area

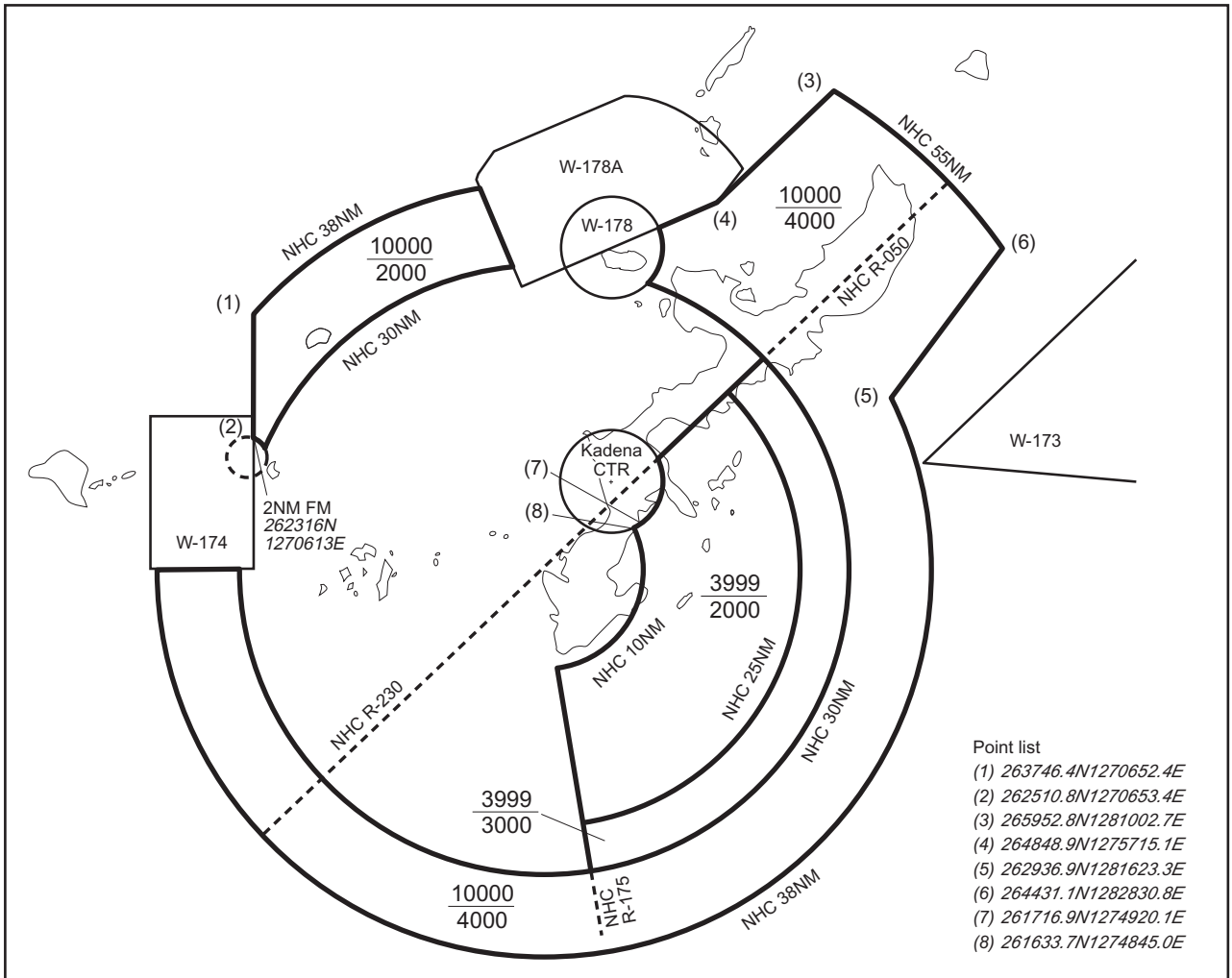

NAHA TCA FREQUENCY

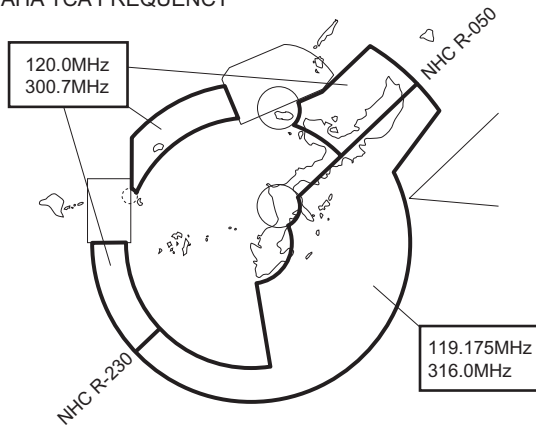

Naha Terminal Control Area and Naha Positive Control Area

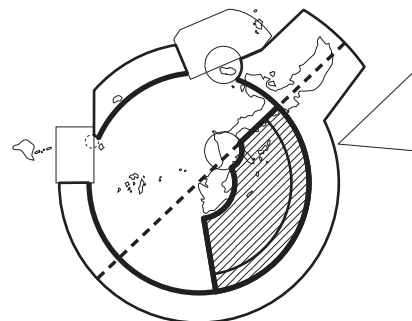

那覇ターミナルコントロールエリアは、太線部及び網掛け部において那覇特別管制区と接している。  
Naha Terminal Control Area borders on Naha Positive Control Area on bold lines and hatched area.

注意事項

1. パイロットは、那覇ターミナルコントロールエリアと那覇特別管制区の境界に留意し、那覇特別管制区に許可なく入域しないこと。
2. 那覇特別管制区への入域を要求する場合、パイロットは那覇TCAにその旨を通報し指示に従うこと。

CAUTION

1. Pilots shall pay attention to the boundary between Naha Terminal Control Area and Naha Positive Control Area, and shall remain outside Naha Positive Control Area unless obtained clearance.
2. When intending to enter Naha Positive Control Area, pilots shall inform Naha TCA of their intention, and shall follow the instruction.

## ROAH AD 2.18 ATS COMMUNICATION FACILITIES

Service designation	Call sign	Frequency	Hours of operation	Remarks
1	2	3	4	5
DEP	Naha Departure	119.1MHz(1) 335.8MHz(1) 126.5MHz(2) 258.3MHz(2) 119.65MHz 228.2MHz	H24	(1) Primary for airspace northwest of Naha VORTAC R050/R230 (2) Primary for airspace southeast of Naha VORTAC R050/R230
APP	Naha Approach	119.1MHz(1) 335.8MHz(1) 126.5MHz(2) 258.3MHz(2) 119.65MHz 228.2MHz 121.2MHz 124.95MHz(3) 280.1MHz(3)	H24	(3) Primary for airspace within 55NM from Kasari VOR/DME
ARR	Naha Arrival	118.85MHz(4) 278.5MHz(4)	H24	(4) Primary for aircraft landing at Naha Airport
	Kadena Arrival	135.9MHz(5) 255.8MHz(5) 285.4MHz	H24	(5) Primary for aircraft landing at Kadena AB and MCAS Futenma
ASR	Naha Radar	120.0MHz 121.1MHz 122.45MHz 125.55MHz 119.65MHz 121.2MHz 228.2MHz 257.5MHz 261.4MHz 270.6MHz 287.8MHz 289.4MHz 290.3MHz 297.2MHz  310.0MHz 317.8MHz 321.5MHz 363.8MHz 121.5MHz(E) 243.0MHz(E)	H24	
TCA	Naha TCA	120.0MHz(6) 310.0MHz 122.45MHz 321.5MHz 119.175MHz(7) 300.7MHz(6) 316.0MHz(7)	2230-1130	(6) Primary for Naha Terminal Control Area northwest of Naha VORTAC R050/R230 (7) Primary for Naha Terminal Control Area southeast of Naha VORTAC R050/R230
TWR	Naha Tower	118.1MHz 126.2MHz 236.6MHz 308.6MHz 121.5MHz(E) 243.0MHz(E) 118.75MHz 247.8MHz	H24	
GND	Naha Ground	121.8MHz 284.6MHz 121.9MHz 284.4MHz	H24	
DLVRY	Naha Delivery	122.075MHz 256.0MHz	H24	

Service designation	Call sign	Frequency		Hours of operation	Remarks
1	2	3		4	5
GCA-ASR -PAR	Naha GCA	119.5MHz 121.1MHz 124.7MHz 261.4MHz 288.1MHz 289.4MHz 296.3MHz 121.5MHz(E) 243.0MHz(E)	119.05MHz 120.6MHz 123.85MHz 236.8MHz 304.5MHz 318.2MHz	0100-1200	GLIDE PATH (1) RWY 18L: 3.0° (2) RWY 36R: 3.0° (3) RWY 18R: 3.0° (4) RWY 36L: 3.0°
ATIS	Naha Airport	127.8MHz 293.0MHz		H24	

## ROAH AD 2.19 RADIO NAVIGATION AND LANDING AIDS

Type of aid (VOR declination)	ID	Frequency	Hours of operation	Position of transmitting antenna coordinates	Elevation of DME transmitting antenna	Remarks
1	2	3	4	5	6	7
VOR (5°W/2014)	NHC	116.5MHz	H24	261230.71N/1273834.32E		
TACAN	NHC	1199MHz (CH-112X)	H24	261229.51N/1273833.44E	56.8ft	TACAN AZM Unusable: 340°-030° beyond 35nm BLW 3,000ft. 060°-070° beyond 35nm BLW 3,000ft. 070°-120° beyond 30nm BLW 3,000ft. 120°-130° beyond 20nm BLW 3,000ft. 130°-150° beyond 25nm BLW 3,000ft. 150°-160° beyond 30nm BLW 3,000ft. 170°-180° beyond 35nm BLW 3,000ft. 240°-300° beyond 35nm BLW 3,000ft.
ILS-LOC 36R	IOK	110.3MHz	H24	261239.35N/1273840.95E		LOC : 177.5m (582ft) away FM RWY 18L THR. 45m(148ft) W of RCL. LOC off-set 0.63° BRG (MAG) 002°
ILS-GP 36R	-	335.0MHz	H24	261106.67N/1273842.59E		GP: 328m (1076ft) inside FM RWY 36R THR. 120m(394ft) W of RCL. Angle 3.0° HGT of ILS Ref datum 17.4m(57ft).
ILS-DME 36R	IOK	1001MHz (CH-40X)	H24	261107.00N/1273841.98E	28ft	DME: 336.4m(1104ft) inside FM RWY 36R THR. 134.9m(443ft) W of RCL.
ILS-LOC 18R	ION	110.15MHz	H24	261033.64N/1273803.22E		LOC : 301.5m (990ft) away FM RWY 36L THR. 55m(180ft) E of RCL. LOC off-set 0.84° BRG (MAG) 182°
ILS-GP 18R	-	334.25MHz	H24	261200.70N/1273801.29E		GP: 322.6m (1058ft) inside FM RWY 18R THR. 115m(377ft) E of RCL. Angle 3.0° HGT of ILS Ref datum 15.8m(52ft).
ILS-DME 18R	ION	1125MHz (CH-38Y)	H24	261200.55N/1273801.65E	31ft	DME: 327.6m(1075ft) inside FM RWY 18R THR. 125m(410ft) E of RCL.
ILS-LOC 36L	IOW	111.7MHz	H24	261221.27N/1273756.17E		LOC : 316.0m (1037ft) away FM RWY 18R THR. BRG (MAG) 003°
ILS-GP 36L	-	333.5MHz	H24	261053.50N/1273755.98E		GP: 317.7m (1042ft) inside FM RWY 36L THR. 120m(394ft) W of RCL. Angle 3.0° HGT of ILS Ref datum 16.5m(55ft).
ILS-DME 36L	IOW	1015MHz (CH-54X)	H24	261053.81N/1273755.60E	32ft	DME: 327.7m(1075ft) inside FM RWY 36L THR. 130m(427ft) W of RCL.
MSAS	-	1575.42MHz	H24			Transmitting antennas are satellite based



ILS for RWY 36R

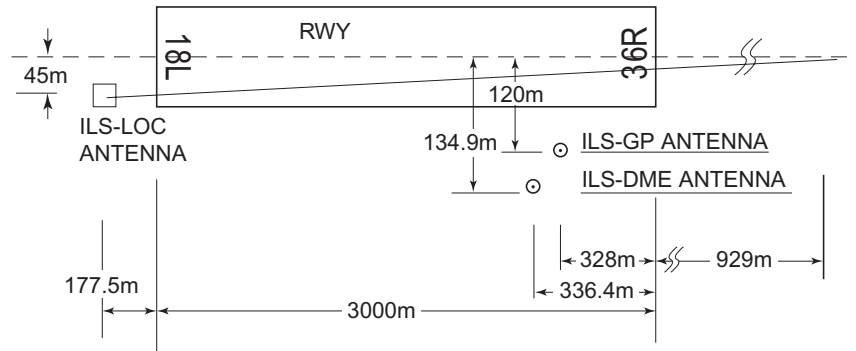

REMARKS :

1. LOC OFFSET Angle 0.63°
2. LOC beam BRG (MAG) 002°
3. GP Angle 3.0°
4. HGT of ILS REF datum 17.4m (57ft)
5. ELEV of ILS-DME 8.48m (28ft)

ILS for RWY18R

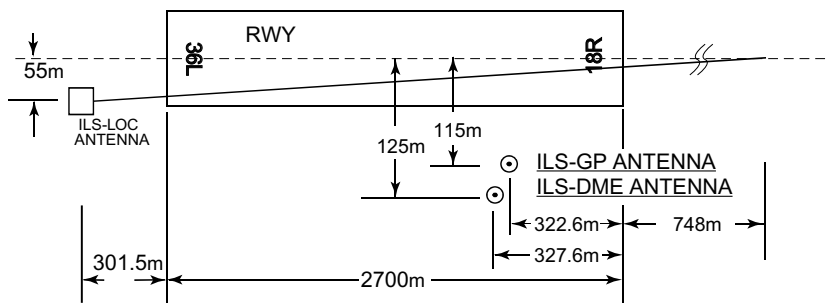

- REMARKS :
1. LOC OFFSET Angle 0.84°
  2. LOC beam BRG(MAG) 182°
  3. GP Angle 3.0°
  4. HGT of ILS REF datum 15.8m(52ft)
  5. ELEV of ILS-DME 9.3m(31ft)

ILS for RWY36L

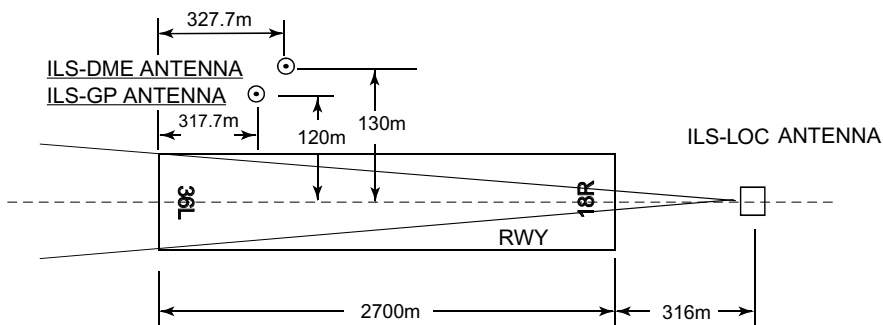

- REMARKS :
1. LOC beam BRG (MAG) 003°
  2. GP Angle 3.0°
  3. HGT of ILS REF datum 16.5m(55ft)
  4. ELEV of ILS-DME 9.6m(32ft)

ROAH AD 2.20 LOCAL TRAFFIC REGULATIONS

1. Airport regulations

<p><b>1.1 定期便以外の航空機の取扱い</b> 定期便以外の航空機による当空港の使用については、事前に空港管理者と調整すること。詳細については、大阪航空局那覇空港事務所航空管制運航情報官に連絡すること。 (電話：098-857-1107)</p>	<p><b>1.1 Aircraft other than scheduled</b> Use of this airport by aircraft other than scheduled is all subject to prior arrangements with the airport administrator. Contact JCAB Naha operations for further details. (Tel:098-857-1107)</p>
---	--

<p><b>1.2 管制方式</b> 航空機の運航者は、次に掲げる方式に従うこと。</p> <p>(1) 一般事項</p> <p>A. パイロットは、那覇空港の標準計器出発方式、標準計器到着方式及び計器進入方式に公示される高度制限について、事前確認を徹底した上で、確実に高度制限を遵守して飛行すること。</p> <p>B. 第 6 エプロン内には、管制塔からの不可視区域が存在する。</p> <p>(2) 出発機</p> <p>A. 全ての IFR 出発機は、エンジン始動 5 分前に那覇デリバリーと通信設定し、次に掲げる事項を通報すること。</p> <p>a) 航空機呼出符号 b) 目的地 c) 要求高度（代替要求高度がある場合は、当該高度） d) 駐機位置（スポット番号）</p> <p>B. パイロットは、プッシュバック及び / 又はエンジン始動が遅れる場合、又はそれが予想される場合は、管制官に対してその旨通報すること。ただし、他の航空機の地上交通による遅延、又は出発制御時刻等が付加されたために生じる遅延を除く。</p> <p>C. 那覇特別管制区を飛行しようとする VFR 機は、地上走行前に那覇グランド／タワーに対して、当該管制圏を離脱する飛行方向又は飛行経路及び要求高度を通報すること。那覇グランド／タワーは、那覇レーダーと通信設定を行う周波数及び二次レーダー個別コードを指定する。</p> <p>(3) インターセクション・デパーチャー</p> <p>A. 出発機はパイロットの同意なしに誘導路 E2、T2 及び T8 からのインターセクション・デパーチャーを指示されることがある。誘導路 E2、T2 及び T8 から出発できない場合は、管制官に対してその旨通報すること。</p> <p>B. AD1.1.6.3.2.2(2)に記載されている出発機間の管制間隔は、次に掲げる誘導路から出発する航空機には適用されない。 AD1.1.6.3.2.2(2)における間隔を必要とする航空機は、那覇グランド / タワーに対してその旨通報すること。</p>	<p><b>1.2 ATC Procedures</b> Aircraft operators shall comply with the following procedures.</p> <p>(1) General</p> <p>A. Pilots shall certainly pre-check and surely comply with altitude restrictions published on standard instrument departures, standard instrument arrivals and instrument approach procedures at Naha Airport.</p> <p>B. Invisible areas from control tower exist within APRON NR-6.</p> <p>(2) Departure</p> <p>A. All IFR departing aircraft shall contact Naha Delivery 5 minutes prior to starting engines and advise the following information.</p> <p>a) call sign b) destination c) proposed flight level/altitude (alternative flight levels/altitudes, if any) d) parking position (spot number)</p> <p>B. Pilots shall advise ATC if any delay in push-back and/or engine start-up is experienced or anticipated except when delay has been caused by other ground traffic or departure time restriction such as release time.</p> <p>C. VFR aircraft intending to operate within the Naha Positive Control area shall advise the Naha ground/tower prior to taxi of intended direction or route of flight and proposed altitude to depart from respective Control Zone. The Naha ground/tower will assign a frequency to contact Naha Radar and discrete beacon code.</p> <p>(3) Intersection departure</p> <p>A. Departing aircraft may be instructed intersection departure from TWY E2, T2, T8 without pilot's consent. Aircraft unable to depart from TWY E2, T2, T8 shall advise ATC accordingly.</p> <p>B. Separation for departure as in AD1.1.6.3.2.2(2) will not be applied to aircraft departing from the following TWYs. Aircraft requiring separation in AD1.1.6.3.2.2(2) shall advise "NAHA GROUND/TOWER" accordingly.</p>
--	--

滑走路 RWY	先行機が出発する誘導路 TWY where a leading aircraft departing	後続機が出発する誘導路 TWY where a succeeding aircraft departing
18L	E1, W1	E2
	E3	W2
	E4	W3
	E4C	W3C
36R	E8S	W5
18R	T1	T2
36L	T9	T8

<p>(4) 到着機</p> <p>A. 全ての民間 IFR 到着機は、那覇タワー / GCA との最初の通信設定時において、駐機位置（スポット番号）を通報すること。</p> <p>B. 後続機は他の周波数にいる場合があることから、パイロットは、最寄りの誘導路経路で、又は管制官の指示に従い、遅滞なく滑走路を離脱することによって、滑走路占有時間の短縮に努めること。</p> <p>C. 全ての到着機は、管制官から指定された二次レーダー個別コードを、着陸するまで変更しないこと。ただし、管制官から別途指示された場合は、この限りでない。</p> <p>D. 那覇特別管制区を飛行しようとする VFR 機は、那覇レーダーと通信設定を行う前に ATIS を聴取するよう努め、通信設定時に ATIS 情報を受信した旨、飛行経路及び要求高度を通報すること。</p> <p>E. 那覇タワーと通信設定する VFR 機は、以下の管轄周波数に連絡し、コールサイン、現在位置、高度及び意図を通報し指示を受けること。</p> <p>a) 空港標点から東象限を飛行する航空機 (VRP:PARCO CITY,AJA,YONABARU,MABUNI) Naha TWR:118.1MHz/308.6MHz</p> <p>b) 空港標点から西象限を飛行する航空機 (VRP:SANDO,DONATSU,MAEJIMA, KERAMA NORTH,KERAMA SOUTH) Naha TWR:118.75MHz/247.8MHz</p> <p>(5) 視認進入</p> <p>A. 視認進入を許可された航空機は、進入許可発出時の指定高度にかかわらず、自機に適用される場周経路高度まで速やかに降下すること。ただし、管制官から別途指示された場合は、この限りでない。</p> <p>B. 視認進入を行う航空機は、回転翼機及び後方乱気流区分がライトの固定翼機を除き、騒音軽減のため海上を飛行すること。</p> <p>(6) CDO (Continuous Descent Operation) 那覇空港への CDO は次に掲げる方式に従うこと。</p> <p>1) 適用時間 THETA, KUKUL, SEIFA, VIGER 通過予定時刻が 0130JST から 0555JST の間。</p> <p>2) 対象経路</p> <p>A. 滑走路 36 運用時</p> <p>a) OKUMA から RESORT SOUTH ARRIVAL を経由する経路。</p> <p>b) GUPTI から GUPTI SOUTH ARRIVAL を経由する経路。</p> <p>c) VELNO から VELNO SOUTH ARRIVAL を経由する経路。</p> <p>d) ENTOK から ENTOK SOUTH ARRIVAL を経由する経路。</p> <p>B. 滑走路 18 運用時</p> <p>a) OKUMA から RESORT NORTH ARRIVAL を経由する経路。</p> <p>b) GUPTI から GUPTI NORTH ARRIVAL を経由する経路。</p> <p>c) VELNO から VELNO NORTH ARRIVAL を経由する経路。</p> <p>d) ENTOK から ENTOK NORTH ARRIVAL を経由する経路。</p>	<p>(4) Arrival</p> <p>A. All civil IFR arriving aircraft shall advise parking position (spot number) on initial contact with Naha Tower/GCA.</p> <p>B. Pilots are encouraged to reduce RWY occupancy time by exiting the RWY without delay at the first available taxiway or as instructed by ATC, for succeeding aircraft which may be on a different frequency.</p> <p>C. All arriving aircraft shall remain on discrete beacon code assigned by ATC until making a full stop landing, unless otherwise instructed by ATC.</p> <p>D. VFR aircraft intending to operate within the Naha Positive Control area should monitor ATIS broadcast prior to contacting Naha Radar, and advise ATIS code received, route of flight, and proposed altitude on initial contact.</p> <p>E. VFR aircraft should call Naha TWR to provide the aircraft identification, position, altitude and intention using the following frequency.</p> <p>a) Aircraft operating east side of Naha Control Zone (VRP:PARCO CITY,AJA,YONABARU,MABUNI) Naha TWR:118.1MHz/308.6MHz</p> <p>b) Aircraft operating west side of Naha Control Zone (VRP:SANDO,DONATSU,MAEJIMA, KERAMA NORTH,KERAMA SOUTH) Naha TWR:118.75MHz/247.8MHz</p> <p>(5) Visual approach</p> <p>A. Aircraft cleared for visual approach shall descend to appropriate traffic pattern altitude regardless of the assigned altitude when the approach clearance is issued, unless otherwise instructed by ATC.</p> <p>B. Aircraft, except fixed wing aircraft in light wake turbulence category and rotary wing aircraft, shall remain over the water when conducting visual approach due to noise abatement.</p> <p>(6) CDO (Continuous Descent Operation) Pilot Shall comply following procedures when conduct CDO at Naha AP.</p> <p>1) Applicable time ETA at THETA, KUKUL, SEIFA or VIGER between 1630UTC and 2055UTC.</p> <p>2) Routes applicable for CDO</p> <p>A. When RWY36 in use</p> <p>a) Arrival routes via OKUMA and join RESORT SOUTH ARRIVAL.</p> <p>b) Arrival routes via GUPTI and join GUPTI SOUTH ARRIVAL.</p> <p>c) Arrival routes via VELNO and join VELNO SOUTH ARRIVAL.</p> <p>d) Arrival routes via ENTOK and join ENTOK SOUTH ARRIVAL.</p> <p>B. When RWY18 in use</p> <p>a) Arrival routes via OKUMA and join RESORT NORTH ARRIVAL.</p> <p>b) Arrival routes via GUPTI and join GUPTI NORTH ARRIVAL.</p> <p>c) Arrival routes via VELNO and join VELNO NORTH ARRIVAL.</p> <p>d) Arrival routes via ENTOK and join ENTOK NORTH ARRIVAL.</p>
--	---

<p>3)実施方式</p> <p>A.CDO の要求及び承認</p> <p>a) 航空機からの CDO の要求及び管制機関からの承認は、次表の CDO 経路名を用いて行う。CDO 経路には高度制限が付加されていることに留意すること。</p> <p>b) 使用滑走路が変更になった場合、CDO が再承認されるか、中止が指示される。</p> <p>B.CDO の要求時期</p> <p>航空機は、降下開始点に到達する時刻の10分前までに、THETA, KUKUL, SEIFA, VIGER 通過予定時刻及び降下開始点を付して、管制機関に対して CDO の要求を行うこと。</p>	<p>3)Procedures</p> <p>A.Request and clearance of CDO</p> <p>a)CDO route name listed below is used when pilot requests CDO and when ATC clears CDO. There are altitude restrictions on CDO routes.</p> <p>b)ATC reclears or cancels CDO when RWY in use is changed.</p> <p>B.Timing for requesting CDO</p> <p>Pilot should request CDO not later than 10minutes before reaching Top of Descent(TOD) with position of TOD and estimated time over THETA, KUKUL, SEIFA or VIGER.</p>
--	--

Runway 36	
CDR Route name	Route
Runway 36 CDO Number 1	ONC A582 OKUMA "RESORT SOUTH ARRIVAL" [Altitude Restriction] Cross HASSA at or above 11,000ft and cross SEIFA at or above 2,000ft.
Runway 36 CDO Number 2	GUPTI "GUPTI SOUTH ARRIVAL" [Altitude Restriction] Cross GUPTI at or above FL200, cross HASSA at or above 11,000ft and cross SEIFA at or above 2,000ft.
Runway 36 CDO Number 3	MJC Y57 VELNO "VELNO SOUTH ARRIVAL" [Altitude Restriction] Cross VIGER at or above 2,000ft.
Runway 36 CDO Number 4	ENTOK "ENTOK SOUTH ARRIVAL" [Altitude Restriction] Cross ENTOK at or above FL170 and cross VIGER at or above 2,000ft.
Runway 18	
CDR Route name	Route
Runway 18 CDO Number 1	ONC A582 OKUMA "RESORT NORTH ARRIVAL" [Altitude Restriction] Cross CLIFF at or above 2,700ft and cross KUKUL at or above 2,000ft.
Runway 18 CDO Number 2	GUPTI "GUPTI NORTH ARRIVAL" [Altitude Restriction] Cross GUPTI at or above FL200 and cross KUKUL at or above 2,000ft.
Runway 18 CDO Number 3	MJC Y57 VELNO "VELNO NORTH ARRIVAL" [Altitude Restriction] Cross THETA at or above 2,000ft.
Runway 18 CDO Number 4	ENTOK "ENTOK NORTH ARRIVAL" [Altitude Restriction] Cross ENTOK at or above FL170, cross YEEZY at or above 2,100ft and cross THETA at or above 2,000ft.

<p><b>1.3 PDA (parts departing aircraft) reporting to Airport Administration</b></p> <p>In order to secure the safety of aircraft operations and to rectify the issue of falling objects from aircraft operating in the vicinity of Naha Airport, aircraft operators are required to notify Airport Administration (Tel 098-857-1107) of any "Parts Departing Aircraft" from flights operating to/from Naha Airport, without delay. This information shall be shared by relevant parties in order to prevent recurrence of such.</p>
--

<p><b>1.4 補助動力装置 (APU) の使用制限</b></p> <p>航空機が固定動力設備付きのスポットを使用する場合は、管理者が特に必要と認める場合を除き、次に掲げる時間を超えて補助動力装置を使用してはならない。</p> <p>(1) 出発予定時刻前の 30 分間</p> <p>(2) 到着後、固定動力設備が使用可能となるまでの最小限度の時間</p> <p>(3) 航空機が点検整備のため補助動力装置を必要とする場合は、それに要する最小限度の時間</p> <p>備考： スポット 21 ~ 27 及び 31 ~ 37 は、固定動力設備が設置されている。</p>	<p><b>1.4 Restrictions about the use of auxiliary power units(APU)</b></p> <p>The APU should be operated only within the following time period the aircraft is on an aircraft parking stand with fixed power facilities. Exceptions apply when airport authority deems it necessary.</p> <p>(1) Within 30 minutes prior to the estimated time of departure(ETD).</p> <p>(2) For the minimum time required for switching over to the fixed power facilities.</p> <p>(3) For the minimum time required for aircraft maintenance purposes, if needed.</p> <p>NOTE: Aircraft parking stands 21-27 and 31-37 are equipped with fixed power facilities.</p>
---	---

2. Taxiing to and from stands

<p><b>2.1 Taxiing procedure</b></p> <p>All aircraft are required to hold at "GP HOLD LINE" on TWY T1 and T2 for RWY18R until receiving taxi clearance to protect the ILS glide slope signal.</p>	
<p><b>2.2 エプロンにおける安全対策について</b></p> <p>1) エプロン内においては、正確に黄色い導入線に沿って走行すること。</p> <p>2) ジェットブラストによる地上の車両、設備及び隣接スポットの他の航空機への影響を回避するため、エプロン内においては、エンジン出力を最小にすること。</p>	<p><b>2.2 Safety measures in Aprons</b></p> <p>1) While operating in the apron area, follow strictly yellow guide line.</p> <p>2) In order to avoid jet blast damage to ground vehicles, equipment and other aircraft in adjacent spots, engine power should be kept to minimum within APRON.</p>

3. Parking area for small aircraft(General aviation)

See AD2.9 Marking AIDs and Parkings Area(West side)

4. Parking area for helicopters

See AD2.9 Marking AIDs and Parkings Area(West side)

5. Apron - taxiing during winter conditions

Nil

6. Taxiing - limitations

**1. Wing tip clearance at the TWY intersection** (REF. AD1.1.6.8)  
Wing tip clearance at the TWY intersection between the aircraft holding at the stop marking on the TWY and the other aircraft taxiing behind it are as follows.

(1) When B744 holding at the stop marking on TWY E1, E2, E3, E4C, E6, E8S, E9

Wing Span (WS) of aircraft taxiing on TWY A1-A4, A5-A6 or A7-A9	WS ≤ 51.1m	51.1m < WS ≤ 68.1m	WS > 68.1m
Wing tip clearance	*A	*B	*C

(2) When B744 holding at the stop marking on TWY W2

Wing Span (WS) of aircraft taxiing on TWY B	WS ≤ 52.1m	52.1m < WS ≤ 69.1m	WS > 69.1m
Wing tip clearance	*A	*B	*C

(3) When B744 holding at the stop marking on TWY T1, T2, T8

Wing Span (WS) of aircraft taxiing on TWY C	WS ≤ 18.1m	18.1m < WS ≤ 35.1m	WS > 35.1m
Wing tip clearance	*A	*B	*C

Legend:  
\*A : wing tip clearance ≥ 15m  
\*B : 6.5m ≤ wing tip clearance < 15m  
\*C : wing tip clearance < 6.5m

**2. Restricted TWY**  
Taxiing from E5 to A5, and vice versa, AVBL wheelbase 9.8m or less, YS11, P3, C1, C130 and US1, for example.

<p><b>3. 航空機重量制限</b> 誘導路 A8 及び W5 を使用する A350-900 型機においては、航空機重量が下表の値を超えてはならない。</p>	<p><b>3. Aircraft weight restriction</b> When A350-900 using TWY A8 and W5, aircraft weight shall not exceed the values listed in the table below.</p>			
	A8		W5	
誘導路 TWY	(lb)	(kg)	(lb)	(kg)
航空機重量 Aircraft weight	533,500	242,000	474,200	215,100

7. School and training flights - technical test flights - use of runways

Nil
-----

8. Helicopter traffic - limitation

Nil
-----

9. Removal of disabled aircraft from runways

Nil
-----

**ROAH AD 2.21 NOISE ABATEMENT PROCEDURES**

Nil
-----

**ROAH AD 2.22 FLIGHT PROCEDURES**

**1. TAKE OFF MINIMA**

	RWY	ACFT CAT	REDL & RCLL		REDL or RCLL or RCL marking		NIL (DAYTIME ONLY)	
			RVR	VIS	RVR	VIS	RVR	VIS
Multi-Engine ACFT with TKOF ALTN AP FILED	18L	A,B,C,D	400m	400m	400m	400m	-	500m
	18R		400m	400m	400m	400m	-	500m
	36R		400m	400m	400m	400m	-	500m
	36L		400m	400m	400m	400m	-	500m
OTHER	18L 18R 36R 36L	A,B,C,D	AVBL LDG MINIMA					

**2. WX MINIMA CONCERNING PAR APCH PROCEDURE**

PAR RWY 18L

MINIMA		THR ELEV: 11	AD ELEV: 11	
CAT	PAR		CIRCLING	
	DA(H)	RVR/CMV	MDA(H)	VIS
A	211(200)	700	620(609)	1600
B				2400
C				
D				3200

Circling to WEST side of RWY only

PAR RWY 36R

MINIMA		THR ELEV: 9	AD ELEV: 11	
CAT	PAR		CIRCLING	
	DA(H)	RVR/CMV	MDA(H)	VIS
A	219(210)	600	620(609)	1600
B	229(220)			
C	239(230)			2400
D	249(240)			

Circling to WEST side of RWY only

PAR RWY 18R

MINIMA		THR ELEV: 16	AD ELEV: 11	
CAT	PAR		CIRCLING	
	DA(H)	RVR/CMV	MDA(H)	VIS
A	216(200)	550	620(609)	1600
B				2400
C				
D				3200

Circling to WEST side of RWY only

PAR RWY 36L

MINIMA		THR ELEV: 14	AD ELEV: 11	
CAT	PAR		CIRCLING	
	DA(H)	RVR/CMV	MDA(H)	VIS
A	214(200)	550	620(609)	1600
B				
C				2400
D				

Circling to WEST side of RWY only

**3. PAR Missed Approach Procedure**

Unless otherwise instructed by ATC, execute each missed approach procedure as follows.

- (1) RWY18L: At guidance limit, climb to 1200FT via NHC R182 to NHC15.0DME, climb to 2000FT via NHC 15.0DME clockwise ARC to OLVAL and hold. Contact NAHA APP.
- (2) RWY36R : At guidance limit, climb to 1200FT on HDG 003° to NHC 2.4DME, turn left, via NHC R341 to NHC 15.0DME, climb to 2000FT via NHC 15.0DME counterclockwise ARC to OLVAL and hold. Contact NAHA APP.
- (3) RWY18R : At guidance limit, turn right, climb to 1200FT via NHC R226 to NHC 15.0DME, climb to 2000FT via NHC 15.0DME clockwise ARC to OLVAL and hold. Contact NAHA APP.
- (4) RWY36L : At guidance limit, turn left, climb to 1200FT via NHC R308 to NHC 8.5DME, climb to 2000FT via NHC R308 to NHC 15.0DME, via NHC 15.0DME counterclockwise ARC to OLVAL and hold. Cross NHC R308/12.0DME at or above 1400FT. Contact NAHA APP.

**4. Lost communication procedures for arrival aircraft under radar navigational guidance**

If radio communications with Naha Approach/Arrival/GCA are lost for 1 minute, or 5 seconds on final approach(PAR), squawk Mode A/3 Code 7600 and :

- (1) Contact Naha Tower.
- (2) If unable, proceed in accordance with Visual Flight Rules.
- (3) If unable,  
Proceed to OLVAL at the last assigned altitude or 2,000FT whichever is higher and execute Instrument Approach.

Note : Procedures other than above will be issued when required.

**5. Trajectory Airport Traffic Data Processing System (TAPS)**

那覇アプローチの指示のもとに、当該進入管制区を飛行する航空機は、モード A/3 の二次レーダー個別コード及びモード C による応答を指示される。  
二次レーダー個別コードを搭載していない航空機が、当該コードによる応答を指示された場合は、管制官に対してその旨通報すること。

Aircraft flying under control of Naha Approach in the Approach Control Area will be instructed to reply with discrete beacon code on Mode A/3 and Mode C.  
If an aircraft with non-discrete beacon code capability is instructed to reply with discrete beacon code, it shall advise ATC accordingly.

**6. 場周経路高度**

- (1) 東側場周経路
  - A. 固定翼機  
最大離陸重量 7000kg 以下…………… 1,000ft
  - B. 回転翼機…………… 800ft
- (2) 西側場周経路
  - A. 固定翼機
    - a) ジェット機  
戦闘機及び練習機…………… 1,700ft  
その他…………… 1,000ft
    - b) プロペラ機  
最大離陸重量 7000kg 超…………… 1,000ft  
最大離陸重量 7000kg 以下…………… 700ft
  - B. 回転翼機…………… 500ft

**6. Traffic Pattern Altitude**

- (1) East side
  - A.FIXED-WING AIRCRAFT  
Maximum take-off weight 7000kg or less…………… 1,000ft
  - B.ROTARY-WING AIRCRAFT…………… 800ft
- (2) West side
  - A.FIXED-WING AIRCRAFT
    - a) JET  
Fighter and Trainer…………… 1,700ft  
Others…………… 1,000ft
    - b) PROPELLER  
Maximum take-off weight more than 7000kg……1,000ft  
Maximum take-off weight 7000kg or less…………… 700ft
  - B.ROTARY-WING AIRCRAFT…………… 500ft



ROAH AD 2.23 ADDITIONAL INFORMATION

1. RWY18L 進入区域の船舶の通過

航空機の運航に影響がある高さの船舶が RWY18L 進入区域を通過する場合、以下の対応が取られる。

- 1) NOTAM ROAH 又は ATC により船舶の情報提供が行われる。
- 2) 以下の場合において、船舶が A 点～ B 点を通過する間、待機が指示されることがある。
  - a) RWY18L 着陸時  
船舶高 35m(115ft)/MSL 超の場合、PAR 進入を行う到着機  
船舶高 43m(142ft)/MSL 超の場合、全ての到着機
  - b) RWY36R 出発時及び着陸時  
船舶高 65m(214ft)/MSL 超の場合、IFR 出発機  
船舶高 96m(315ft)/MSL 超の場合、IFR 到着機

1. Passage of vessel across RWY18L approach area

While vessel with height that affects ACFT operations is passing across RWY18L approach area, the following action will be taken.

- 1) The information of vessel will be provided by NOTAM ROAH or ATC.
- 2) While vessel is crossing between point A and point B, holding instruction may be issued in the following situations.
  - a) ACFT for landing RWY18L  
When vessel height is above 35m(115ft)/MSL : arrival ACFT to conduct PAR APCH  
When vessel height is above 43m(142ft)/MSL : all arrival ACFT
  - b) ACFT for take-off/landing RWY36R  
When vessel height is above 65m(214ft)/MSL : IFR departure ACFT  
When vessel height is above 96m(315ft)/MSL : IFR arrival ACFT

船舶経路

VESSEL COURSE

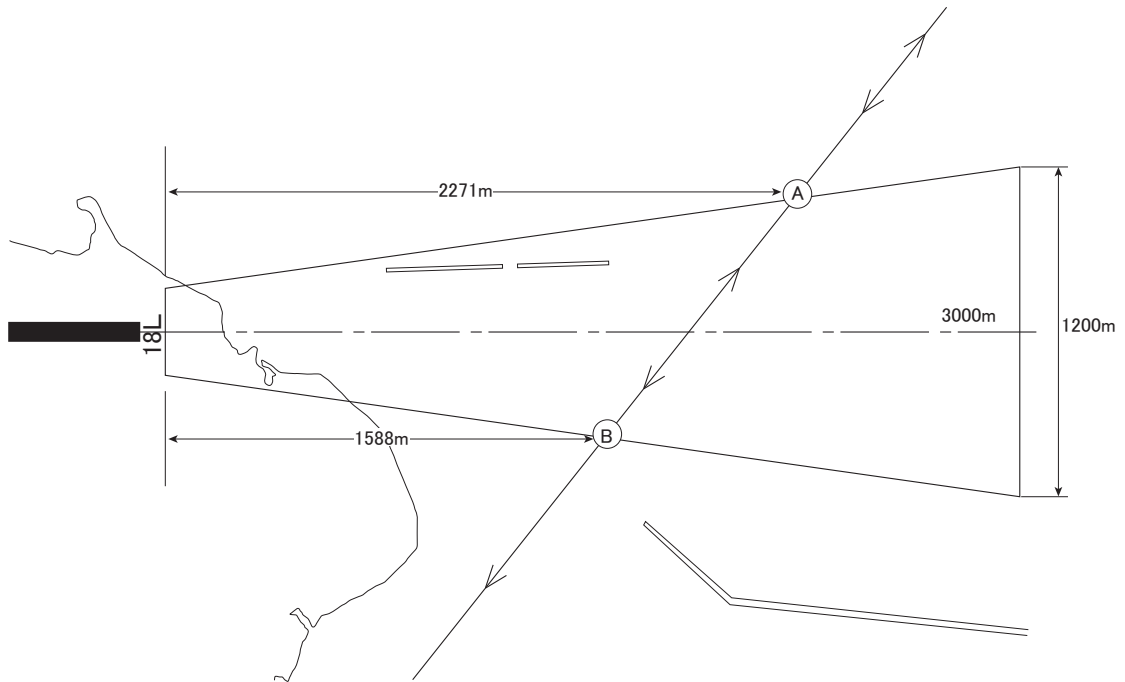

2. 滑走路上での維持工事

滑走路及び空港施設の維持工事のため、計画的な滑走路閉鎖が行われる。  
(NOTAM ROAH 参照)

2. Schedule maintenance on the RWY

Scheduled RWY unavailability due to RWY and facilities maintenance.  
(See NOTAM ROAH)

<p><b>3. その他</b></p> <p>(1) アレスティングギア (型式 : BAK-12)</p> <p>1) 位置 滑走路上の以下の場所にアレスティングギアが装備されている。(飛行場面図 参照)</p> <p>a) RWY36R 進入端から 250M(820ft) 内側 b) RWY36R 進入端から 877M(2,877ft) 内側 c) RWY18L 進入端から 278M(912ft) 内側 d) RWY36L 進入端から 20M(65.6ft) 外側 e) RWY36L 進入端から 589.1M(1,931.5ft) 内側 f) RWY18R 進入端から 20M(65.6ft) 外側 g) RWY18R 進入端から 589.1M(1,931.5ft) 内側</p> <p>2) 通常の運用形態 使用 RWY に応じて、以下のアレスティングギアが RWY 上に張られた状態になっている。 RWY18L: 上記 1) の a) RWY36R: 上記 1) の c) 以下のアレスティングギアが過走帯内に張られた状態になっている。 RWY36L: 上記 1) の d) RWY18R: 上記 1) の f)</p> <p>(2) ジェットバリア (MEN) MEN が RWY36R 及び RWY18L の過走帯端に設置されている。</p> <p>(3) ジェットバリア (型式 : BAK-12/15) BAK-12/15 が RWY36L 及び RWY18R の過走帯端に設置されている。</p> <p>(4) ノース及びサウスヘリパッド ノースヘリパッド及びサウスヘリパッドが B TWY 上に設置されている。 (飛行場面図 参照)</p>	<p><b>3. Other</b></p> <p>(1) Arresting-gear (Type BAK-12)</p> <p>1) Location Arresting-gears are installed on the RWY as follow. (See Aerodrome Chart)</p> <p>a) 250M(820ft) from RWY36R THR b) 877M(2,877ft) from RWY36R THR c) 278M(912ft) from RWY18L THR d) 20M(65.6ft) from outside RWY36L THR e) 589.1M(1,931.5ft) from inside RWY36L THR f) 20M(65.6ft) from outside RWY18R THR g) 589.1M(1,931.5ft) from inside RWY18R THR</p> <p>2) Normal configuration The following arresting-gear shall remain in the ready position for the RWY in use. RWY18L: paragraph 1) a) above RWY36R: paragraph 1) c) above The following arresting-gear shall remain in the ready position for the overrun. RWY36L: paragraph 1) d) above RWY18R: paragraph 1) f) above</p> <p>(2) Jet barrier (MEN) MENs are located on RWY36R overrun and RWY18L overrun end.</p> <p>(3) Jet barrier (Type BAK-12/15) BAK-12/15s are located on RWY36L overrun and RWY18R overrun end.</p> <p>(4) North and South Helipad North helipad and South helipad are located on B TWY. (See Aerodrome Chart)</p>
--	---

### ROAH AD 2.24 CHARTS RELATED TO AN AERODROME

Aerodrome/Heliport Chart -1  
Aerodrome/Heliport Chart -2  
Aerodrome Obstacle Chart - ICAO Type A (RWY18L/36R)  
Aerodrome Obstacle Chart - ICAO Type A (RWY18R/36L)  
Aerodrome Obstacle Chart - ICAO Type B  
Standard Departure Chart - Instrument (NAHA NORTH, LAVON, OLVAL, NAHA SOUTHWEST)  
Standard Departure Chart - Instrument (ESKOB-RNAV)  
Standard Departure Chart - Instrument (KIZNA-RNAV)  
Standard Departure Chart - Instrument (DORIS, GANJU-RNAV)  
Standard Arrival Chart - Instrument (SCUBA, LAVON, LAFTY)  
Standard Arrival Chart - Instrument (IHEYA NORTH, VELNO NORTH-RNAV)  
Standard Arrival Chart - Instrument (RESORT NORTH-RNAV)  
Standard Arrival Chart - Instrument (GUPTI NORTH, ENTOK NORTH-RNAV)  
Standard Arrival Chart - Instrument (IHEYA SOUTH, VELNO SOUTH-RNAV)  
Standard Arrival Chart - Instrument (RESORT SOUTH-RNAV)  
Standard Arrival Chart - Instrument (GUPTI SOUTH, ENTOK SOUTH-RNAV)  
Instrument Approach Chart (ILS Z or LOC Z RWY36R)  
Instrument Approach Chart (ILS Y or LOC Y RWY36R)  
Instrument Approach Chart (ILS X or LOC X RWY36R)  
Instrument Approach Chart (ILS Z or LOC Z RWY36L)  
Instrument Approach Chart (ILS Y or LOC Y RWY36L)  
Instrument Approach Chart (ILS X or LOC X RWY36L)  
Instrument Approach Chart (ILS or LOC RWY18R)  
Instrument Approach Chart (RNP RWY36R)  
Instrument Approach Chart (RNP RWY36L)  
Instrument Approach Chart (RNP RWY18R)  
Instrument Approach Chart (RNP RWY18L)  
Instrument Approach Chart (VOR A or TACAN B)  
Instrument Approach Chart (VOR C)  
Instrument Approach Chart (TACAN D)  
Other Chart (Visual REP)  
Other Chart (MVA CHART)

AERODROME CHART

NAHA AIRPORT  
ELEV 11ft (3.3m)

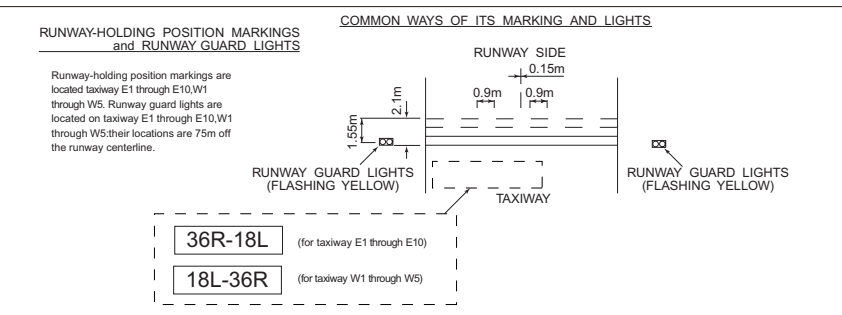
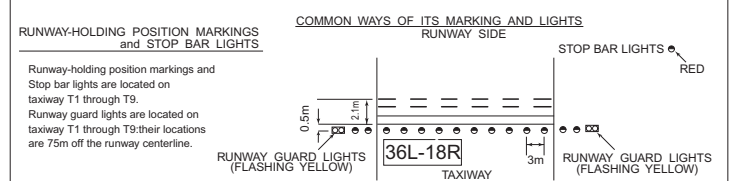
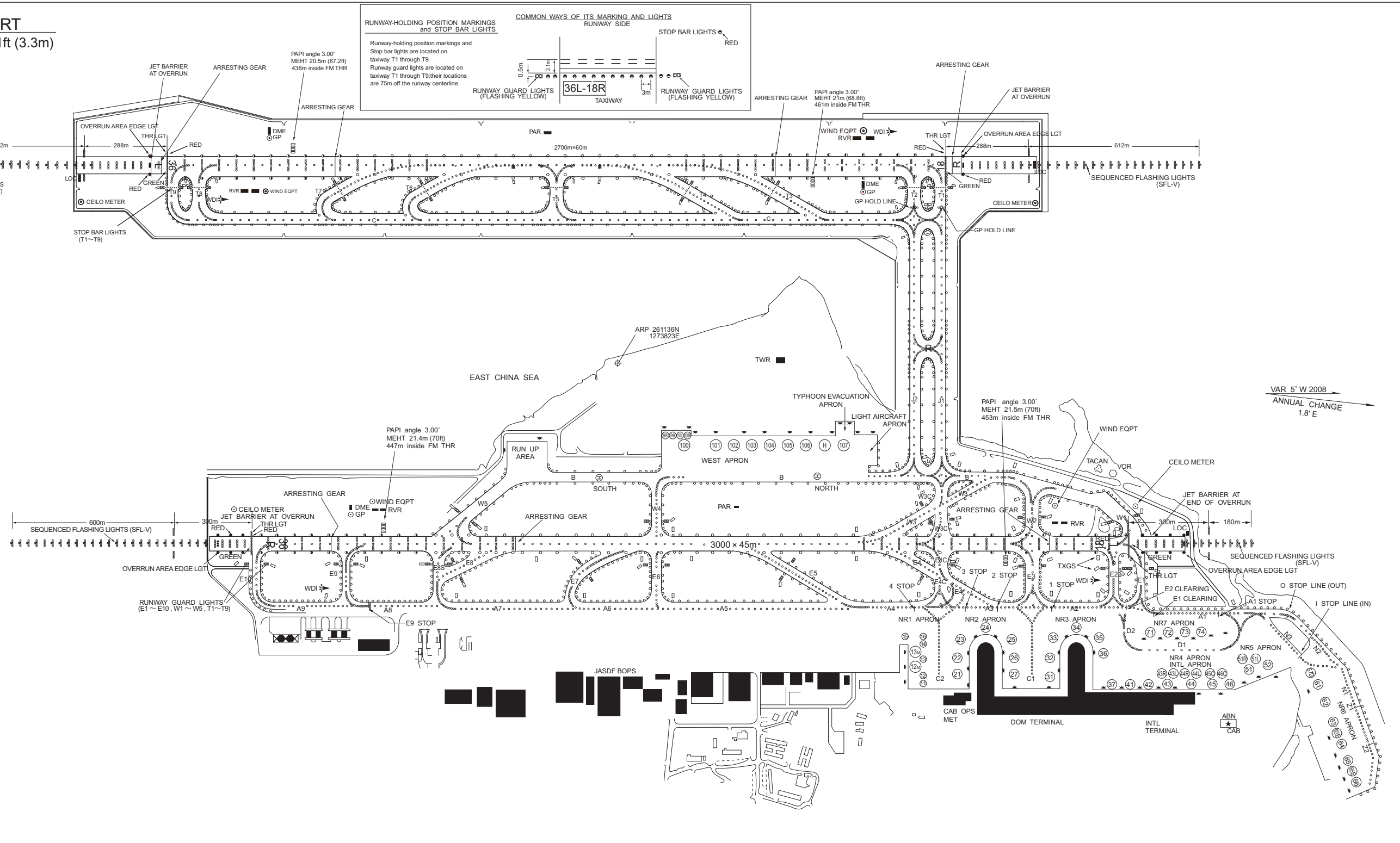

CHANGE : RTZL for RWY18L installed.

ROAH / NAHA

AD CHART

CHANGE: Stop line(M1,K1) relocated.

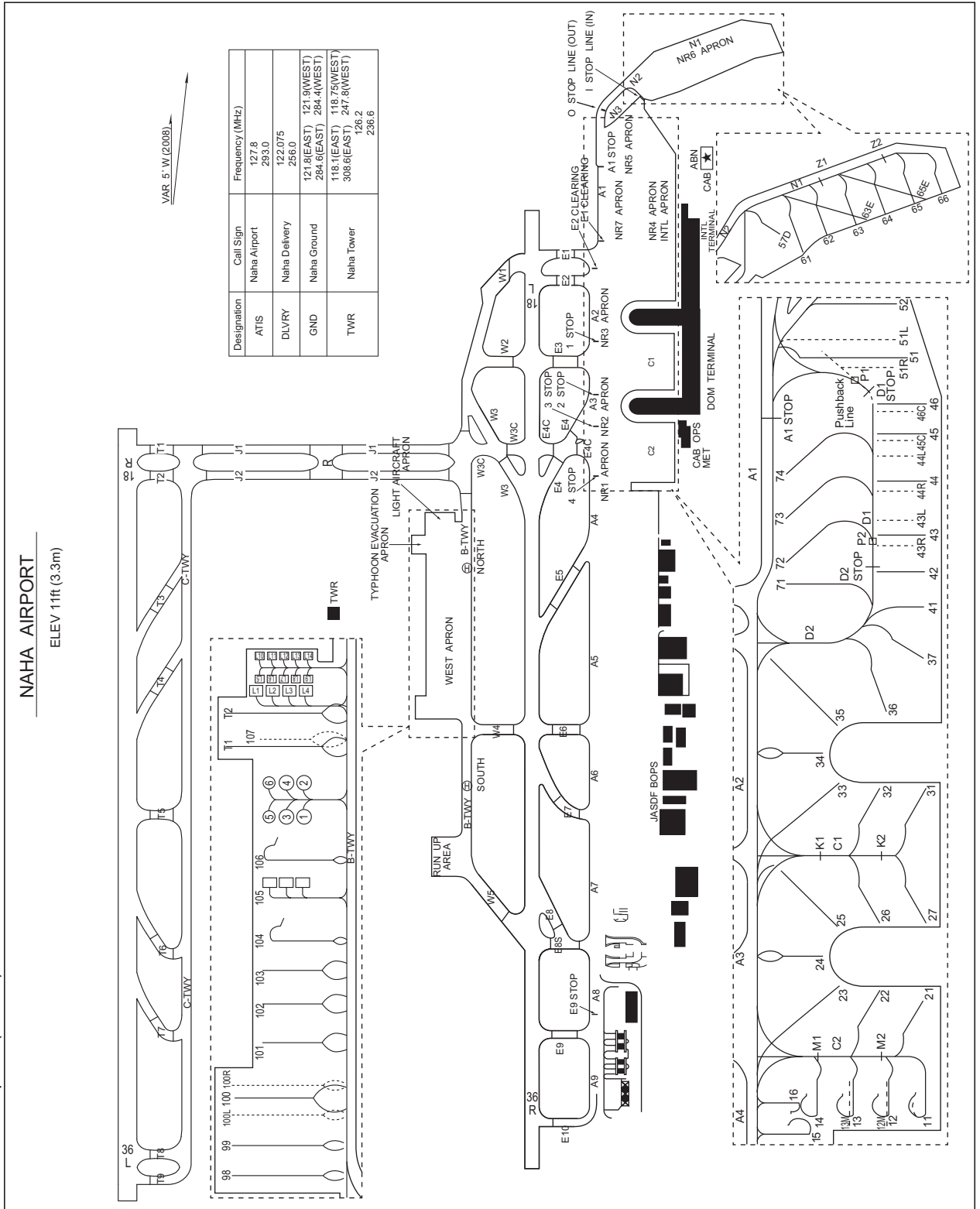

**INTENTIONALLY LEFT BLANK**

AERODROME OBSTACLE CHART-ICAO  
TYPE A (OPERATING LIMITATIONS)

DIMENSIONS AND ELEVATIONS IN FEET BEARINGS ARE MAGNETIC  
Transverse Mercator Projection

MAGNETIC VARIATION 6°W - FEB 2023

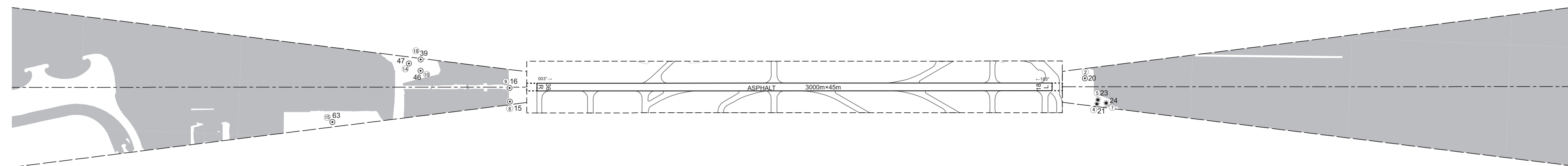
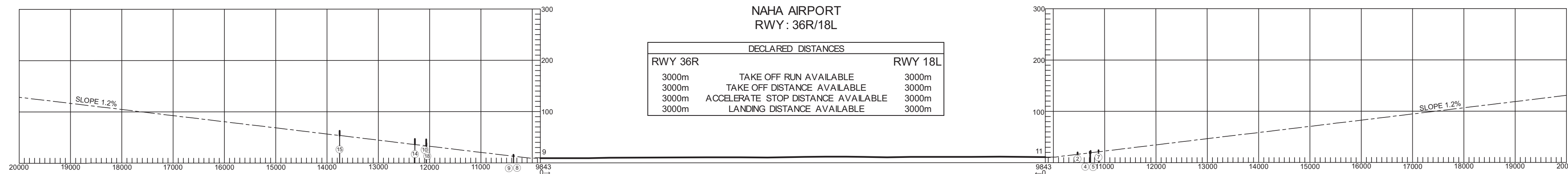

HORIZONTAL SCALE

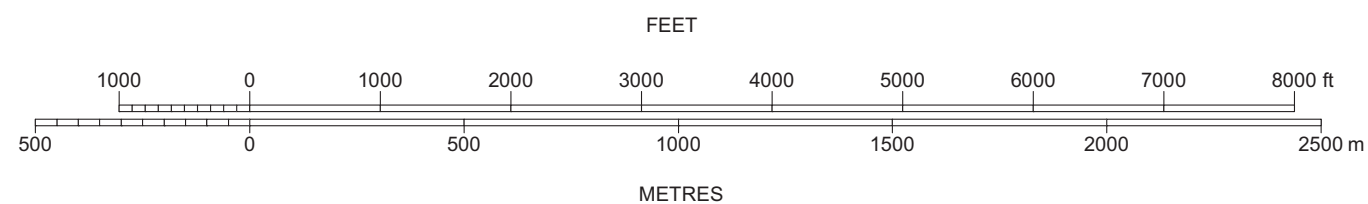

LEGEND		AMENDMENT RECORD		
		Nr	DATE	ENTERED BY
①	IDENTIFICATION NUMBER			
⊙	POLE, TOWER, SPIRE, ANTENNA, ETC			
*	TREE			
— — —	RAILROAD			
—+—+—	TRANSMISSION LINE OR OVERHEAD CABLE			
△	TRIANGULATION POINT			
★	AERONAUTICAL GROUND LIGHT			
■	BUILDING OR LARGE STRUCTURE			
⋯	CONTOURS(1)			
*	OBSTRUCTION LIGHT			

測量法に基づく国土地理院長承認(使用) R 4Jts 286

CHANGE : Update.

DIMENSIONS AND ELEVATIONS IN FEET BEARINGS ARE MAGNETIC  
Transverse Mercator Projection

AERODROME OBSTACLE CHART-ICAO  
TYPE A (OPERATING LIMITATIONS)

MAGNETIC VARIATION 6°W - FEB 2023

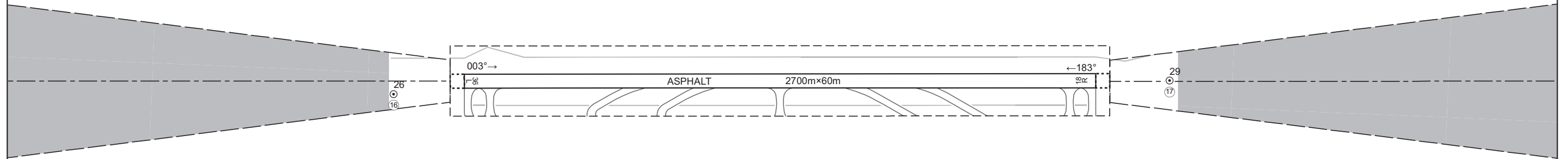
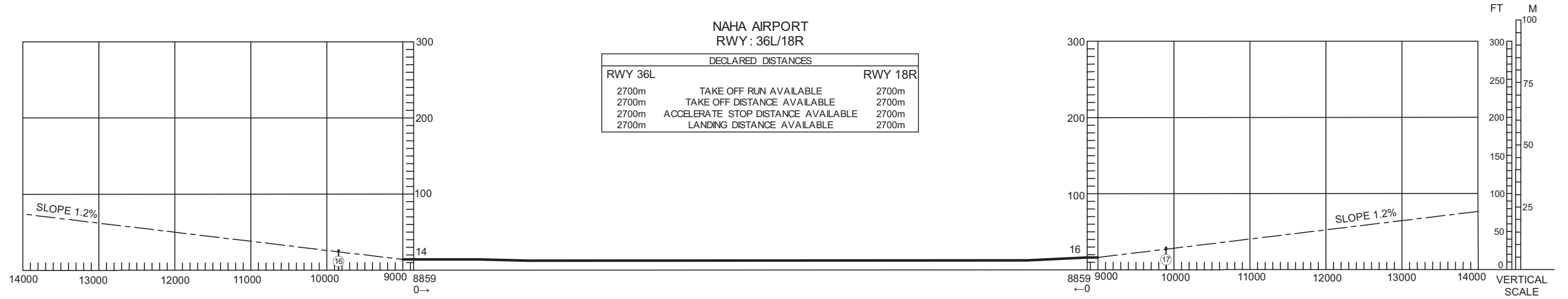

HORIZONTAL SCALE

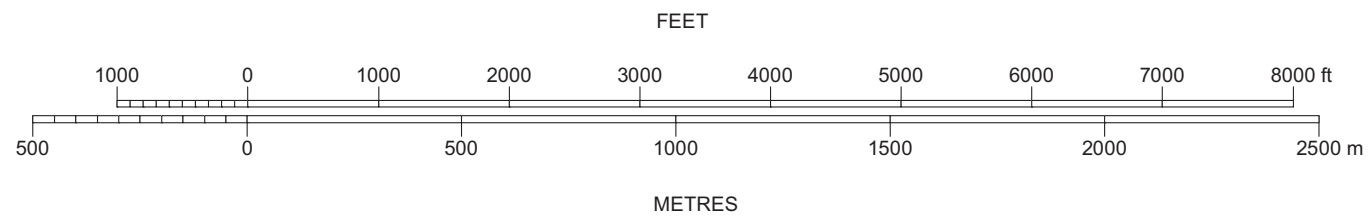

LEGEND			AMENDMENT RECORD		
			Nr	DATE	ENTERED BY
①	IDENTIFICATION NUMBER				
⊙	POLE, TOWER, SPIRE, ANTENNA, ETC				
✳	TREE	▬			
+	RAILROAD	~			
---	TRANSMISSION LINE OR OVERHEAD CABLE	~			
△	TRIANGULATION POINT				
★	AERONAUTICAL GROUND LIGHT				
■	BUILDING OR LARGE STRUCTURE				
⋯	CONTOURS(ft)				
✳	OBSTRUCTION LIGHT				

測量法に基づく国土地理院長承認(使用) R 4.Jhs 286

CHANGE : Update.



DIMENSIONS AND ELEVATIONS IN FEET BEARINGS ARE MAGNETIC  
Transverse Mercator Projection

AERODROME OBSTACLE CHART-ICAO  
TYPE B

AERODROME ELEVATION 11ft ARP

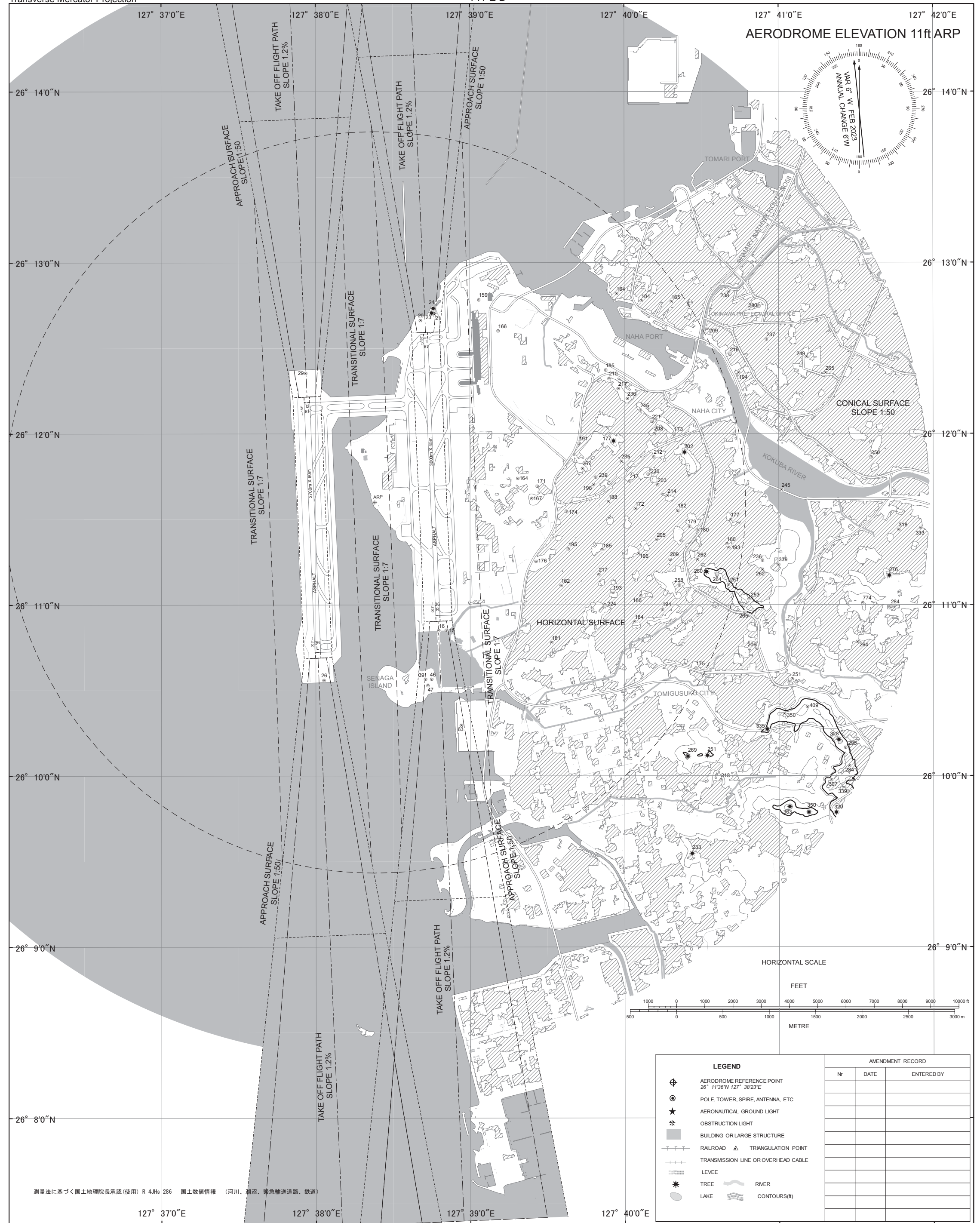

CHANGE : Update.

測量法に基づく国土地理院長承認(使用) R 4Jhs 286 国土数値情報 (河川、湖沼、緊急輸送道路、鉄道)



STANDARD DEPARTURE CHART-INSTRUMENT

ROAH/ NAHA

SID

NAHA NORTH FOUR DEPARTURE

RWY18L/18R: (Not established)  
RWY36R : Climb RWY HDG to NHC 2.4DME,...  
RWY36L : Climb RWY HDG to 500FT,...  
...turn left, via NHC R341 to EISAR.

Note RWY36R/36L: 5.0% climb gradient required up to 500FT.

SCUBA TRANSITION

From over EISAR, via NHC R341 to 24.1DME, turn right to intercept NHC R344 to SCUBA.  
Cross SCUBA at or above 4000FT.

LAVON ONE DEPARTURE

RWY18L : Climb RWY HDG to NHC 4.7DME, turn right, via NHC R196...  
RWY18R : Climb RWY HDG to 600FT, turn right, via NHC R211...  
... to intercept and proceed via NHC 15.0DME clockwise ARC to LAVON.

RWY36R : Climb RWY HDG to NHC 2.4DME, turn left, via NHC R341...  
RWY36L : Climb RWY HDG to 500FT, turn left, via NHC R308...  
...to intercept and proceed via NHC 15.0DME counterclockwise ARC to LAVON.

Note RWY36R/36L: 5.0% climb gradient required up to 500FT.

OLVAL ONE DEPARTURE

RWY18L : Climb RWY HDG to NHC 4.7DME, turn right, via NHC R196...  
RWY18R : Climb RWY HDG to 600FT, turn right, via NHC R211...  
... to intercept and proceed via NHC 15.0DME clockwise ARC to OLVAL.

RWY36R : Climb RWY HDG to NHC 2.4DME, turn left, via NHC R341...  
RWY36L : Climb RWY HDG to 500FT, turn left, via NHC R308...  
...to intercept and proceed via NHC 15.0DME counterclockwise ARC to OLVAL.

Note RWY36R/36L: 5.0% climb gradient required up to 500FT.

NAHA SOUTHWEST FOUR DEPARTURE

RWY18L : Climb RWY HDG to NHC 4.7DME,...  
RWY18R : Climb RWY HDG to 500FT,...  
... turn right, via NHC R196 to LAFTY.  
RWY36R/36L: (Not established)

CHANGE:New PROC

STANDARD DEPARTURE CHART-INSTRUMENT

ROAH/NAHA

SID

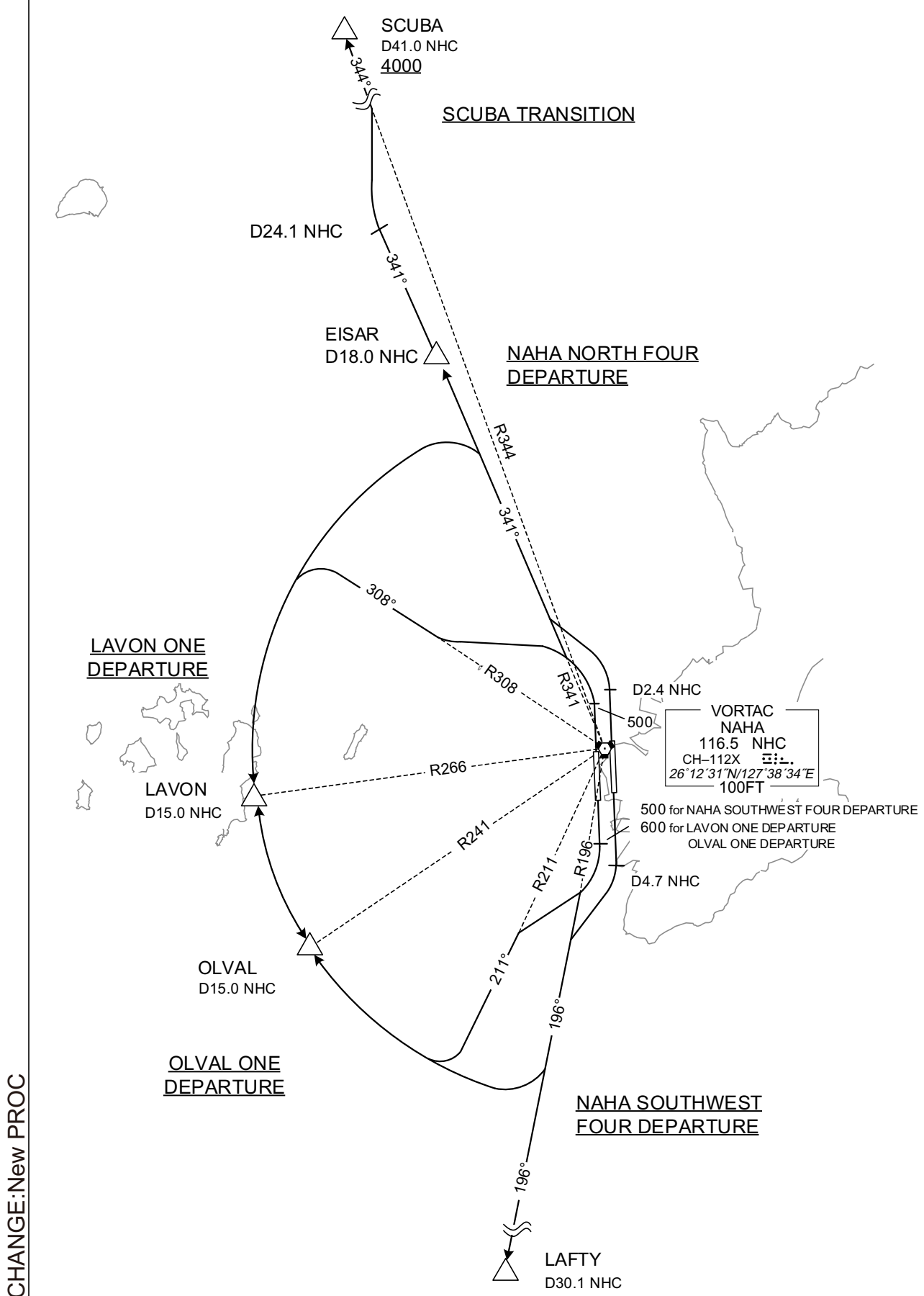

STANDARD DEPARTURE CHART-INSTRUMENT

ROAH/NAHA

RNAV SID

ESKOB THREE DEPARTURE

RNP1

Note GNSS required.

VAR 6°W

CHANGE : Navigation Specification(Basic RNP1 → RNP1).

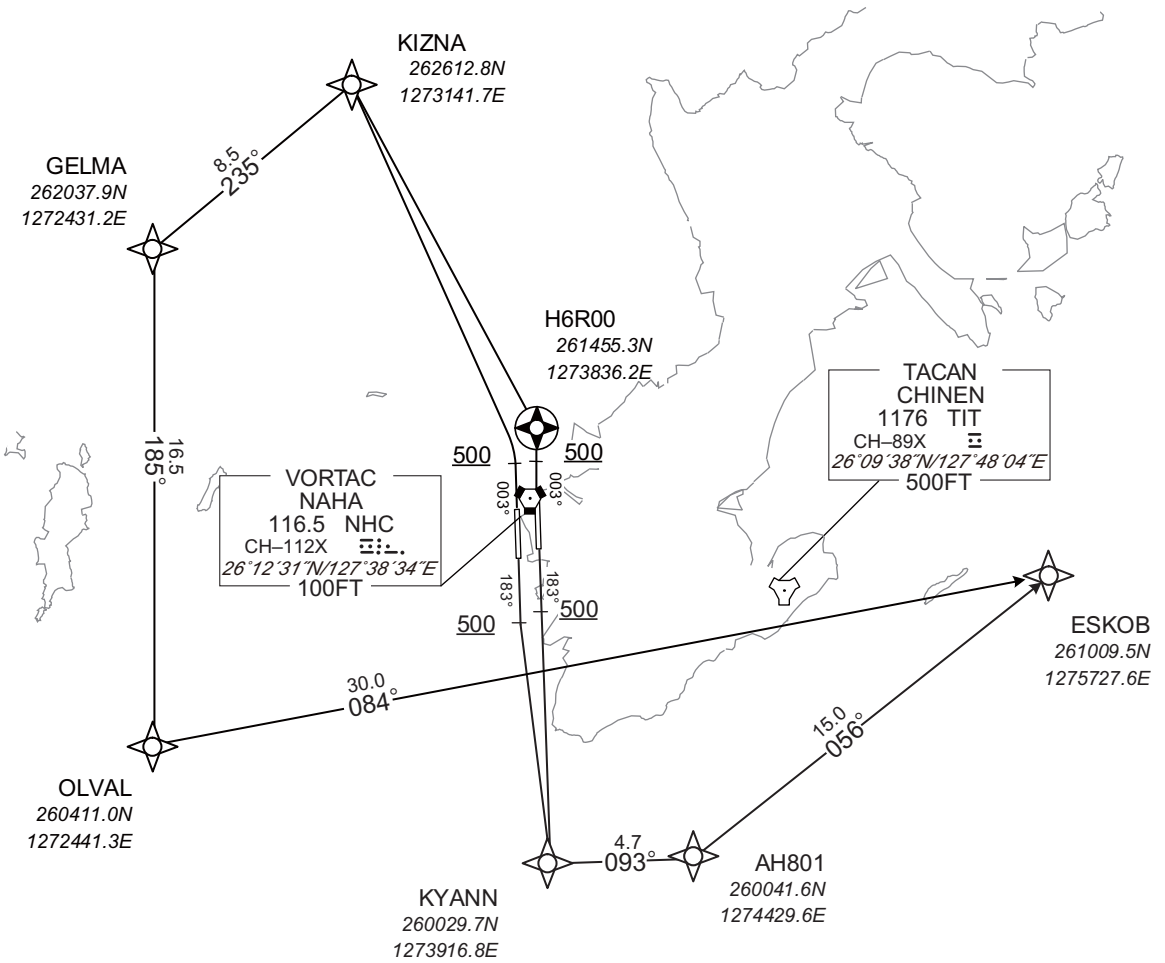

RWY18L : Climb on HDG183° at or above 500FT, direct to KYANN, to AH801, to ESKOB.  
 RWY18R : Climb on HDG183° at or above 500FT, direct to KYANN, to AH801, to ESKOB.  
 RWY36R : Climb on HDG003° at or above 500FT, direct to H6R00, turn left direct to KIZNA, to GELMA, to OLVAL, to ESKOB.  
 RWY36L : Climb on HDG003° at or above 500FT, turn left direct to KIZNA, to GELMA, to OLVAL, to ESKOB.  
 NOTE RWY36R/36L : 5.0% climb gradient required up to 500FT.

STANDARD DEPARTURE CHART-INSTRUMENT

ROAH/ NAHA

RNAV SID

ESKOB THREE DEPARTURE

**RWY18L**

Serial Number	Path Descriptor	Waypoint Identifier	Fly Over	Course °M(°T)	Magnetic Variation	Distance (NM)	Turn Direction	Altitude (FT)	Speed (KIAS)	Vertical Angle	Navigation Specification
001	VA	-	-	183 (177.6)	-5.6	-	-	+500	-	-	RNP1
002	DF	KYANN	-	-	-5.6	-	-	-	-	-	RNP1
003	TF	AH801	-	093 (087.6)	-5.6	4.7	-	-	-	-	RNP1
004	TF	ESKOB	-	056 (050.9)	-5.6	15.0	-	-	-	-	RNP1

**RWY18R**

Serial Number	Path Descriptor	Waypoint Identifier	Fly Over	Course °M(°T)	Magnetic Variation	Distance (NM)	Turn Direction	Altitude (FT)	Speed (KIAS)	Vertical Angle	Navigation Specification
001	VA	-	-	183 (177.6)	-5.6	-	-	+500	-	-	RNP1
002	DF	KYANN	-	-	-5.6	-	-	-	-	-	RNP1
003	TF	AH801	-	093 (087.6)	-5.6	4.7	-	-	-	-	RNP1
004	TF	ESKOB	-	056 (050.9)	-5.6	15.0	-	-	-	-	RNP1

**RWY36R**

Serial Number	Path Descriptor	Waypoint Identifier	Fly Over	Course °M(°T)	Magnetic Variation	Distance (NM)	Turn Direction	Altitude (FT)	Speed (KIAS)	Vertical Angle	Navigation Specification
001	VA	-	-	003 (357.6)	-5.6	-	-	+500	-	-	RNP1
002	DF	H6R00	Y	-	-5.6	-	-	-	-	-	RNP1
003	DF	KIZNA	-	-	-5.6	-	L	-	-	-	RNP1
004	TF	GELMA	-	235 (229.0)	-5.6	8.5	-	-	-	-	RNP1
005	TF	OLVAL	-	185 (179.5)	-5.6	16.5	-	-	-	-	RNP1
006	TF	ESKOB	-	084 (078.4)	-5.6	30.0	-	-	-	-	RNP1

**RWY36L**

Serial Number	Path Descriptor	Waypoint Identifier	Fly Over	Course °M(°T)	Magnetic Variation	Distance (NM)	Turn Direction	Altitude (FT)	Speed (KIAS)	Vertical Angle	Navigation Specification
001	VA	-	-	003 (357.6)	-5.6	-	-	+500	-	-	RNP1
002	DF	KIZNA	-	-	-5.6	-	L	-	-	-	RNP1
003	TF	GELMA	-	235 (229.0)	-5.6	8.5	-	-	-	-	RNP1
004	TF	OLVAL	-	185 (179.5)	-5.6	16.5	-	-	-	-	RNP1
005	TF	ESKOB	-	084 (078.4)	-5.6	30.0	-	-	-	-	RNP1

CHANGE : Navigation Specification(Basic RNP1 → RNP1).

STANDARD DEPARTURE CHART-INSTRUMENT

ROAH/NAHA RNAV TRANSITION

AMAMI TRANSITION / CHERY TRANSITION / YANBARU TRANSITION	RNP1
--	------

Note GNSS required.

VAR 6°W

CHANGE : Navigation Specification(Basic RNP1 → RNP1).

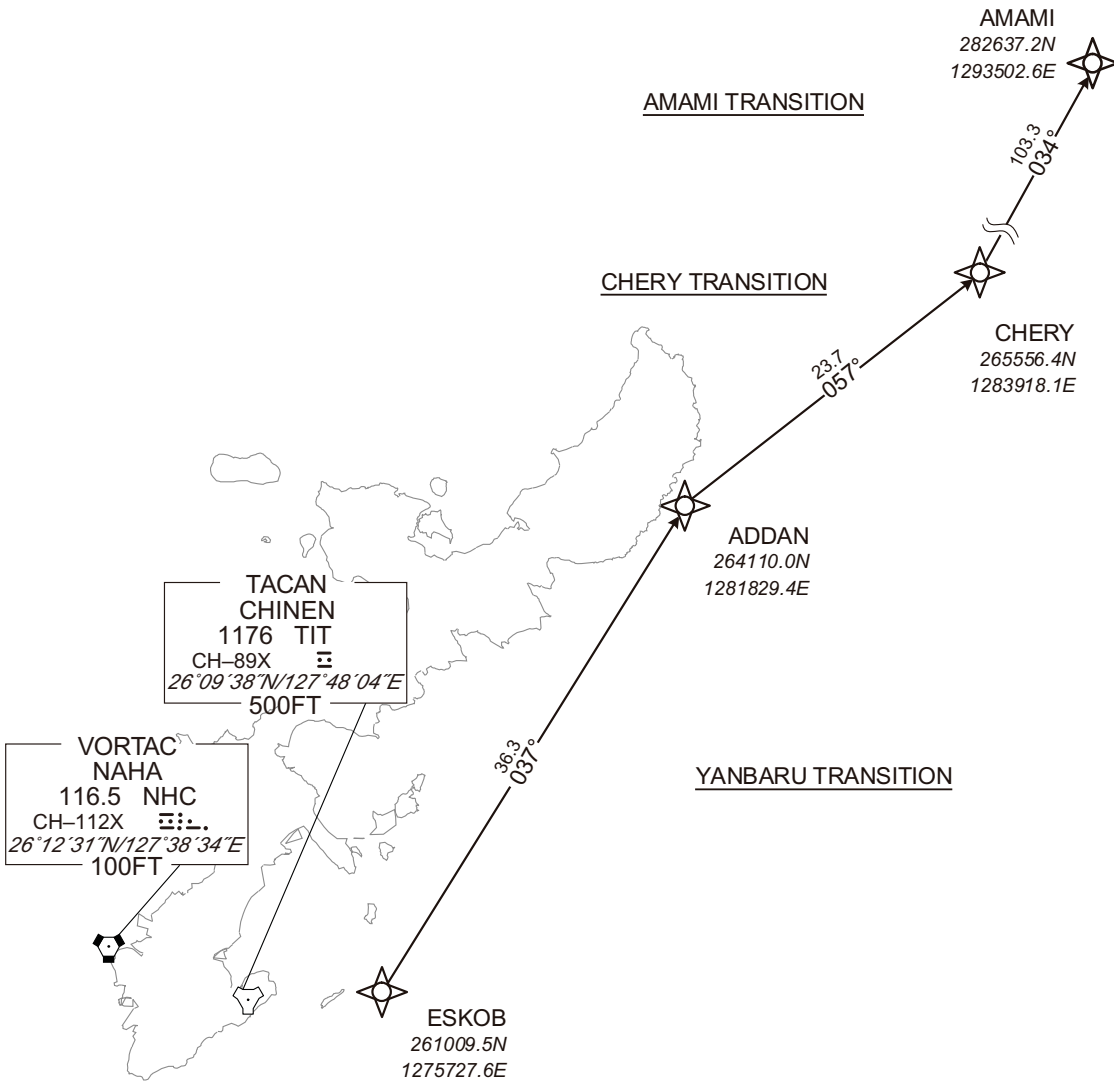

AMAMI TRANSITION

From ESKOB, to ADDAN, to CHERY, to AMAMI.

CHERY TRANSITION

From ESKOB, to ADDAN, to CHERY.

YANBARU TRANSITION

From ESKOB, to ADDAN.

STANDARD DEPARTURE CHART-INSTRUMENT

ROAH / NAHA

RNAV TRANSITION

AMAMI TRANSITION

Serial Number	Path Descriptor	Waypoint Identifier	Fly Over	Course °M(°T)	Magnetic Variation	Distance (NM)	Turn Direction	Altitude (FT)	Speed (KIAS)	Vertical Angle	Navigation Specification
001	IF	ESKOB	-	-	-5.6	-	-	-	-	-	RNP1
002	TF	ADDAN	-	037 (031.2)	-5.6	36.3	-	-	-	-	RNP1
003	TF	CHERY	-	057 (051.4)	-5.6	23.7	-	-	-	-	RNP1
004	TF	AMAMI	-	034 (028.3)	-5.6	103.3	-	-	-	-	RNP1

CHERY TRANSITION

Serial Number	Path Descriptor	Waypoint Identifier	Fly Over	Course °M(°T)	Magnetic Variation	Distance (NM)	Turn Direction	Altitude (FT)	Speed (KIAS)	Vertical Angle	Navigation Specification
001	IF	ESKOB	-	-	-5.6	-	-	-	-	-	RNP1
002	TF	ADDAN	-	037 (031.2)	-5.6	36.3	-	-	-	-	RNP1
003	TF	CHERY	-	057 (051.4)	-5.6	23.7	-	-	-	-	RNP1

YANBARU TRANSITION

Serial Number	Path Descriptor	Waypoint Identifier	Fly Over	Course °M(°T)	Magnetic Variation	Distance (NM)	Turn Direction	Altitude (FT)	Speed (KIAS)	Vertical Angle	Navigation Specification
001	IF	ESKOB	-	-	-5.6	-	-	-	-	-	RNP1
002	TF	ADDAN	-	037 (031.2)	-5.6	36.3	-	-	-	-	RNP1

CHANGE : Navigation Specification(Basic RNP1 → RNP1).

STANDARD DEPARTURE CHART-INSTRUMENT

ROAH/NAHA

RNAV SID and TRANSITION

KIZNA TWO DEPARTURE RESORT TRANSITION	RNP1
--	------

Note GNSS required.

VAR 6°W

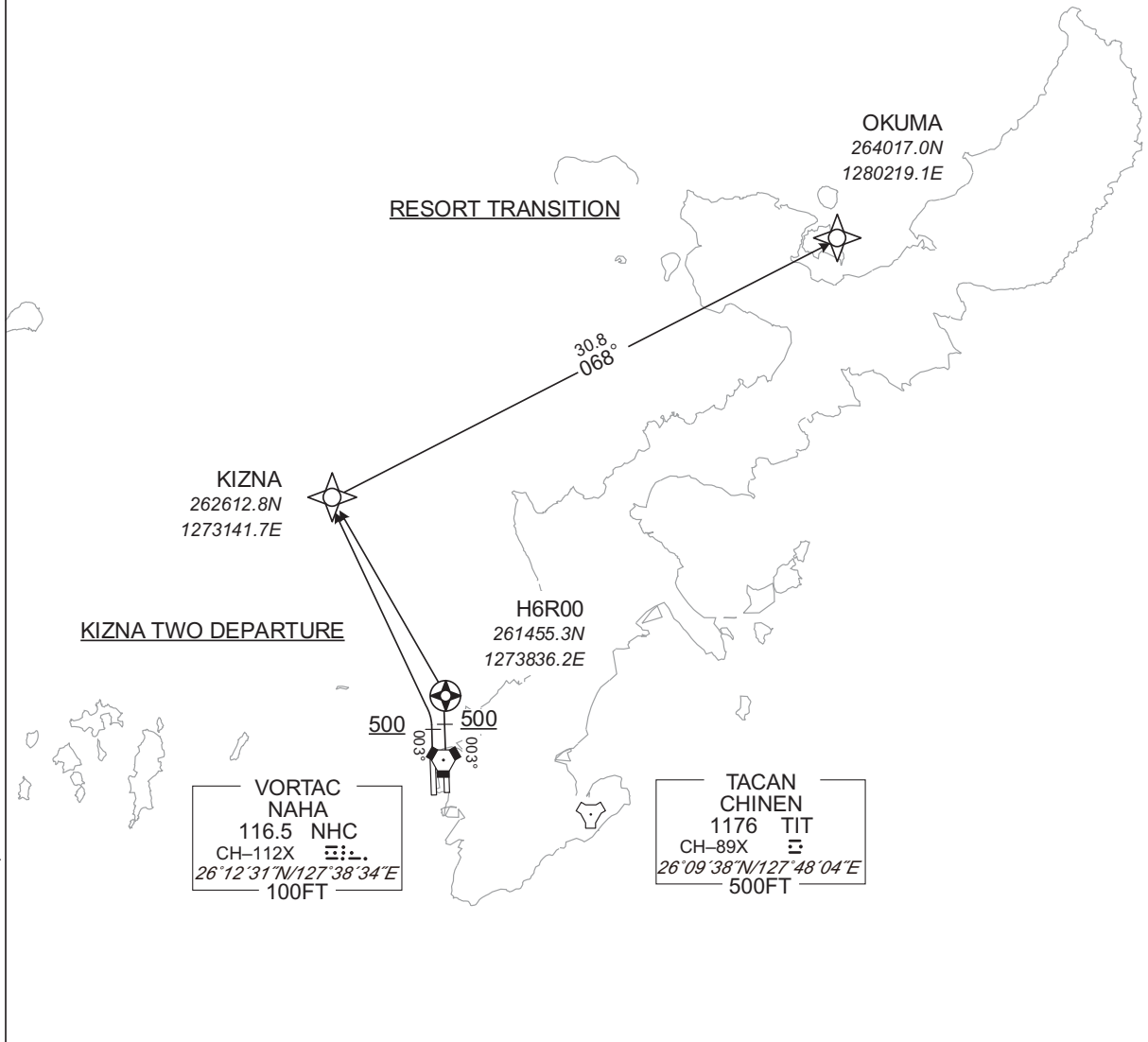

CHANGE : Navigation Specification(Basic RNP1 → RNP1).

KIZNA TWO DEPARTURE

- RWY18L/18R: (Not established)
- RWY36R : Climb on HDG003° at or above 500FT, direct to H6R00, turn left direct to KIZNA .
- RWY36L : Climb on HDG003° at or above 500FT, turn left direct to KIZNA .

NOTE RWY36R/36L: 5.0% climb gradient required up to 500FT.

RESORT TRANSITION

From KIZNA, to OKUMA.

STANDARD DEPARTURE CHART-INSTRUMENT

ROAH/ NAHA

RNAV SID and TRANSITION

KIZNA TWO DEPARTURE

RWY36R

Serial Number	Path Descriptor	Waypoint Identifier	Fly Over	Course °M(°T)	Magnetic Variation	Distance (NM)	Turn Direction	Altitude (FT)	Speed (KIAS)	Vertical Angle	Navigation Specification
001	VA	-	-	003 (357.6)	-5.6	-	-	+500	-	-	RNP1
002	DF	H6R00	Y	-	-5.6	-	-	-	-	-	RNP1
003	DF	KIZNA	-	-	-5.6	-	L	-	-	-	RNP1

RWY36L

Serial Number	Path Descriptor	Waypoint Identifier	Fly Over	Course °M(°T)	Magnetic Variation	Distance (NM)	Turn Direction	Altitude (FT)	Speed (KIAS)	Vertical Angle	Navigation Specification
001	VA	-	-	003 (357.6)	-5.6	-	-	+500	-	-	RNP1
002	DF	KIZNA	-	-	-5.6	-	L	-	-	-	RNP1

RESORT TRANSITION

Serial Number	Path Descriptor	Waypoint Identifier	Fly Over	Course °M(°T)	Magnetic Variation	Distance (NM)	Turn Direction	Altitude (FT)	Speed (KIAS)	Vertical Angle	Navigation Specification
001	IF	KIZNA	-	-	-5.6	-	-	-	-	-	RNP1
002	TF	OKUMA	-	068 (062.7)	-5.6	30.8	-	-	-	-	RNP1

CHANGE : Navigation Specification(Basic RNP1 → RNP1).



STANDARD DEPARTURE CHART-INSTRUMENT

ROAH/NAHA RNAV TRANSITION

KUROUSA TRANSITION CHAMP TRANSITION YUGAF TRANSITION	RNP1
--	------

Note GNSS required.

VAR 6°W

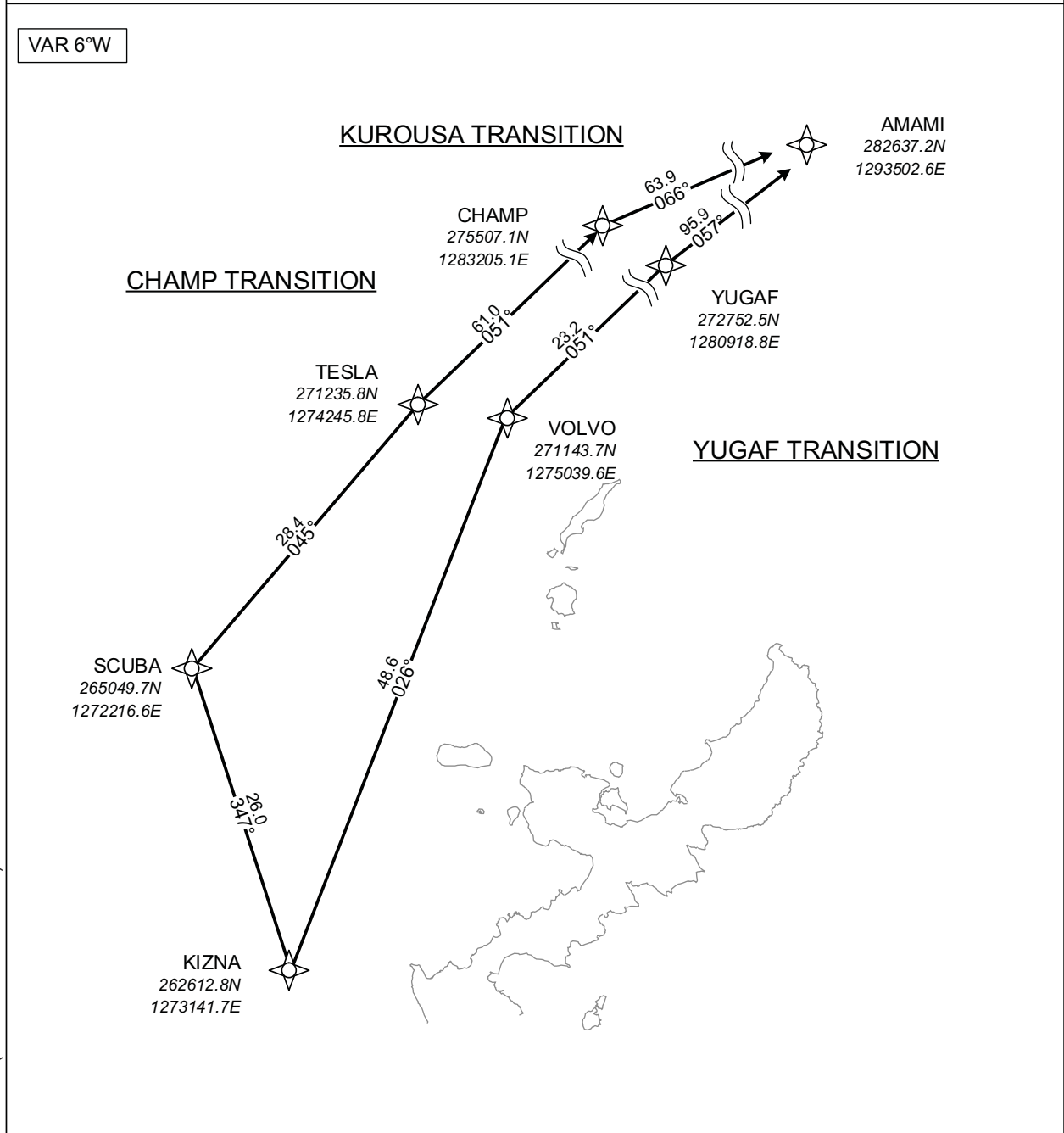

CHANGE : Navigation Specification(Basic RNP1 → RNP1).

**KUROUSA TRANSITION**  
From KIZNA, to SCUBA, to TESLA, to CHAMP, to AMAMI.

**CHAMP TRANSITION**  
From KIZNA, to SCUBA, to TESLA, to CHAMP.

**YUGAF TRANSITION**  
From KIZNA, to VOLVO, to YUGAF, to AMAMI.

STANDARD DEPARTURE CHART-INSTRUMENT

ROAH / NAHA

RNAV TRANSITION

KUROUSA TRANSITION

Serial Number	Path Descriptor	Waypoint Identifier	Fly Over	Course °M(°T)	Magnetic Variation	Distance (NM)	Turn Direction	Altitude (FT)	Speed (KIAS)	Vertical Angle	Navigation Specification
001	IF	KIZNA	-	-	-5.6	-	-	-	-	-	RNP1
002	TF	SCUBA	-	347 (341.2)	-5.6	26.0	-	-	-	-	RNP1
003	TF	TESLA	-	045 (039.9)	-5.6	28.4	-	-	-	-	RNP1
004	TF	CHAMP	-	051 (045.6)	-5.6	61.0	-	-	-	-	RNP1
005	TF	AMAMI	-	066 (060.2)	-5.6	63.9	-	-	-	-	RNP1

CHAMP TRANSITION

Serial Number	Path Descriptor	Waypoint Identifier	Fly Over	Course °M(°T)	Magnetic Variation	Distance (NM)	Turn Direction	Altitude (FT)	Speed (KIAS)	Vertical Angle	Navigation Specification
001	IF	KIZNA	-	-	-5.6	-	-	-	-	-	RNP1
002	TF	SCUBA	-	347 (341.2)	-5.6	26.0	-	-	-	-	RNP1
003	TF	TESLA	-	045 (039.9)	-5.6	28.4	-	-	-	-	RNP1
004	TF	CHAMP	-	051 (045.6)	-5.6	61.0	-	-	-	-	RNP1

YUGAF TRANSITION

Serial Number	Path Descriptor	Waypoint Identifier	Fly Over	Course °M(°T)	Magnetic Variation	Distance (NM)	Turn Direction	Altitude (FT)	Speed (KIAS)	Vertical Angle	Navigation Specification
001	IF	KIZNA	-	-	-5.6	-	-	-	-	-	RNP1
002	TF	VOLVO	-	026 (020.3)	-5.6	48.6	-	-	-	-	RNP1
003	TF	YUGAF	-	051 (045.7)	-5.6	23.2	-	-	-	-	RNP1
004	TF	AMAMI	-	057 (051.9)	-5.6	95.9	-	-	-	-	RNP1

CHANGE : Navigation Specification(Basic RNP1 → RNP1).

STANDARD DEPARTURE CHART-INSTRUMENT

ROAH / NAHA RNAV SID

DORIS TWO DEPARTURE / GANJU TWO DEPARTURE	RNP1
---	------

Note GNSS required.

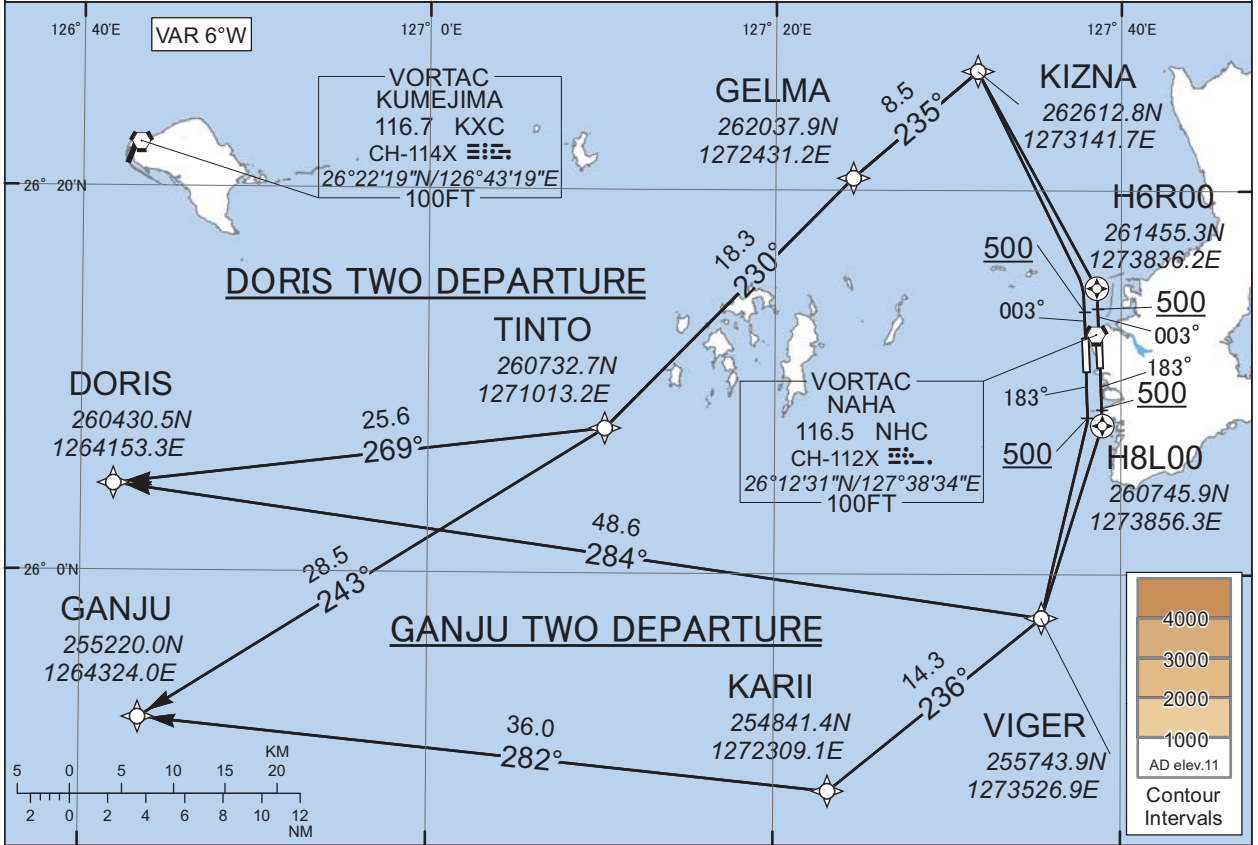

**DORIS TWO DEPARTURE**

- RWY18L : Climb on HDG183° at or above 500FT, direct to H8L00, turn right direct to VIGER, to DORIS.
- RWY18R : Climb on HDG183° at or above 500FT, turn right direct to VIGER, to DORIS.
- RWY36R : Climb on HDG003° at or above 500FT, direct to H6R00, turn left direct to KIZNA, to GELMA, to TINTO, to DORIS.
- RWY36L : Climb on HDG003° at or above 500FT, turn left direct to KIZNA, to GELMA, to TINTO, to DORIS.

Note RWY36R/36L : 5.0% climb gradient required up to 500FT.

**GANJU TWO DEPARTURE**

- RWY18L : Climb on HDG183° at or above 500FT, direct to H8L00, turn right direct to VIGER, to KARII, to GANJU.
- RWY18R : Climb on HDG183° at or above 500FT, turn right direct to VIGER, to KARII, to GANJU.
- RWY36R : Climb on HDG003° at or above 500FT, direct to H6R00, turn left direct to KIZNA, to GELMA, to TINTO, to GANJU.
- RWY36L : Climb on HDG003° at or above 500FT, turn left direct to KIZNA, to GELMA, to TINTO, to GANJU.

Note RWY36R/36L : 5.0% climb gradient required up to 500FT.

CHANGE : Navigation Specification(Basic RNP1 → RNP1).

STANDARD DEPARTURE CHART-INSTRUMENT

ROAH / NAHA

RNAV SID

DORIS TWO DEPARTURE

RWY18L

Serial Number	Path Descriptor	Waypoint Identifier	Fly Over	Course °M(°T)	Magnetic Variation	Distance (NM)	Turn Direction	Altitude (FT)	Speed (KIAS)	Vertical Angle	Navigation Specification
001	VA	-	-	183 (177.6)	-5.6	-	-	+500	-	-	RNP1
002	DF	H8L00	Y	-	-5.6	-	-	-	-	-	RNP1
003	DF	VIGER	-	-	-5.6	-	R	-	-	-	RNP1
004	TF	DORIS	-	284 (278.2)	-5.6	48.6	-	-	-	-	RNP1

RWY18R

Serial Number	Path Descriptor	Waypoint Identifier	Fly Over	Course °M(°T)	Magnetic Variation	Distance (NM)	Turn Direction	Altitude (FT)	Speed (KIAS)	Vertical Angle	Navigation Specification
001	VA	-	-	183 (177.6)	-5.6	-	-	+500	-	-	RNP1
002	DF	VIGER	-	-	-5.6	-	R	-	-	-	RNP1
003	TF	DORIS	-	284 (278.2)	-5.6	48.6	-	-	-	-	RNP1

RWY36R

Serial Number	Path Descriptor	Waypoint Identifier	Fly Over	Course °M(°T)	Magnetic Variation	Distance (NM)	Turn Direction	Altitude (FT)	Speed (KIAS)	Vertical Angle	Navigation Specification
001	VA	-	-	003 (357.6)	-5.6	-	-	+500	-	-	RNP1
002	DF	H6R00	Y	-	-5.6	-	-	-	-	-	RNP1
003	DF	KIZNA	-	-	-5.6	-	L	-	-	-	RNP1
004	TF	GELMA	-	235 (229.0)	-5.6	8.5	-	-	-	-	RNP1
005	TF	TINTO	-	230 (224.5)	-5.6	18.3	-	-	-	-	RNP1
006	TF	DORIS	-	269 (263.3)	-5.6	25.6	-	-	-	-	RNP1

RWY36L

Serial Number	Path Descriptor	Waypoint Identifier	Fly Over	Course °M(°T)	Magnetic Variation	Distance (NM)	Turn Direction	Altitude (FT)	Speed (KIAS)	Vertical Angle	Navigation Specification
001	VA	-	-	003 (357.6)	-5.6	-	-	+500	-	-	RNP1
002	DF	KIZNA	-	-	-5.6	-	L	-	-	-	RNP1
003	TF	GELMA	-	235 (229.0)	-5.6	8.5	-	-	-	-	RNP1
004	TF	TINTO	-	230 (224.5)	-5.6	18.3	-	-	-	-	RNP1
005	TF	DORIS	-	269 (263.3)	-5.6	25.6	-	-	-	-	RNP1

CHANGE : Navigation Specification(Basic RNP1 → RNP1).

STANDARD DEPARTURE CHART-INSTRUMENT

ROAH / NAHA

RNAV SID

GANJU TWO DEPARTURE

**RWY18L**

Serial Number	Path Descriptor	Waypoint Identifier	Fly Over	Course °M(°T)	Magnetic Variation	Distance (NM)	Turn Direction	Altitude (FT)	Speed (KIAS)	Vertical Angle	Navigation Specification
001	VA	-	-	183 (177.6)	-5.6	-	-	+500	-	-	RNP1
002	DF	H8L00	Y	-	-5.6	-	-	-	-	-	RNP1
003	DF	VIGER	-	-	-5.6	-	R	-	-	-	RNP1
004	TF	KARII	-	236 (230.8)	-5.6	14.3	-	-	-	-	RNP1
005	TF	GANJU	-	282 (276.0)	-5.6	36.0	-	-	-	-	RNP1

**RWY18R**

Serial Number	Path Descriptor	Waypoint Identifier	Fly Over	Course °M(°T)	Magnetic Variation	Distance (NM)	Turn Direction	Altitude (FT)	Speed (KIAS)	Vertical Angle	Navigation Specification
001	VA	-	-	183 (177.6)	-5.6	-	-	+500	-	-	RNP1
002	DF	VIGER	-	-	-5.6	-	R	-	-	-	RNP1
003	TF	KARII	-	236 (230.8)	-5.6	14.3	-	-	-	-	RNP1
004	TF	GANJU	-	282 (276.0)	-5.6	36.0	-	-	-	-	RNP1

**RWY36R**

Serial Number	Path Descriptor	Waypoint Identifier	Fly Over	Course °M(°T)	Magnetic Variation	Distance (NM)	Turn Direction	Altitude (FT)	Speed (KIAS)	Vertical Angle	Navigation Specification
001	VA	-	-	003 (357.6)	-5.6	-	-	+500	-	-	RNP1
002	DF	H6R00	Y	-	-5.6	-	-	-	-	-	RNP1
003	DF	KIZNA	-	-	-5.6	-	L	-	-	-	RNP1
004	TF	GELMA	-	235 (229.0)	-5.6	8.5	-	-	-	-	RNP1
005	TF	TINTO	-	230 (224.5)	-5.6	18.3	-	-	-	-	RNP1
006	TF	GANJU	-	243 (237.8)	-5.6	28.5	-	-	-	-	RNP1

**RWY36L**

Serial Number	Path Descriptor	Waypoint Identifier	Fly Over	Course °M(°T)	Magnetic Variation	Distance (NM)	Turn Direction	Altitude (FT)	Speed (KIAS)	Vertical Angle	Navigation Specification
001	VA	-	-	003 (357.6)	-5.6	-	-	+500	-	-	RNP1
002	DF	KIZNA	-	-	-5.6	-	L	-	-	-	RNP1
003	TF	GELMA	-	235 (229.0)	-5.6	8.5	-	-	-	-	RNP1
004	TF	TINTO	-	230 (224.5)	-5.6	18.3	-	-	-	-	RNP1
005	TF	GANJU	-	243 (237.8)	-5.6	28.5	-	-	-	-	RNP1

CHANGE : Navigation Specification(Basic RNP1 → RNP1).

STANDARD ARRIVAL CHART-INSTRUMENT

ROAH/NAHA

STAR

SCUBA ARRIVAL

From over SCUBA, via NHC R344 to 28.1 DME, turn right to intercept and proceed via NHC R341 to EISAR.  
Cross NHC R344/28.1DME at or above 3000FT, cross EISAR at or above 2000FT.

LAVON ARRIVAL

From over LAVON, via NHC 15.0DME counterclockwise ARC to VIGER.  
Cross VIGER at or above 2000FT.

(When using NHC TACAN only)

From over LAVON at or above 5000FT, via NHC 15.0DME counterclockwise ARC to VIGER.

Cross VIGER at or above 4400FT.

LAFTY ARRIVAL

From over LAFTY, via NHC R196 to VIGER.  
Cross VIGER at or above 2000FT.

(When using NHC TACAN only)

From over LAFTY, via NHC R196 to VIGER.  
Cross VIGER at or above 4400FT.

CHANGE: New PROC

STANDARD ARRIVAL CHART-INSTRUMENT

ROAH/NAHA

STAR

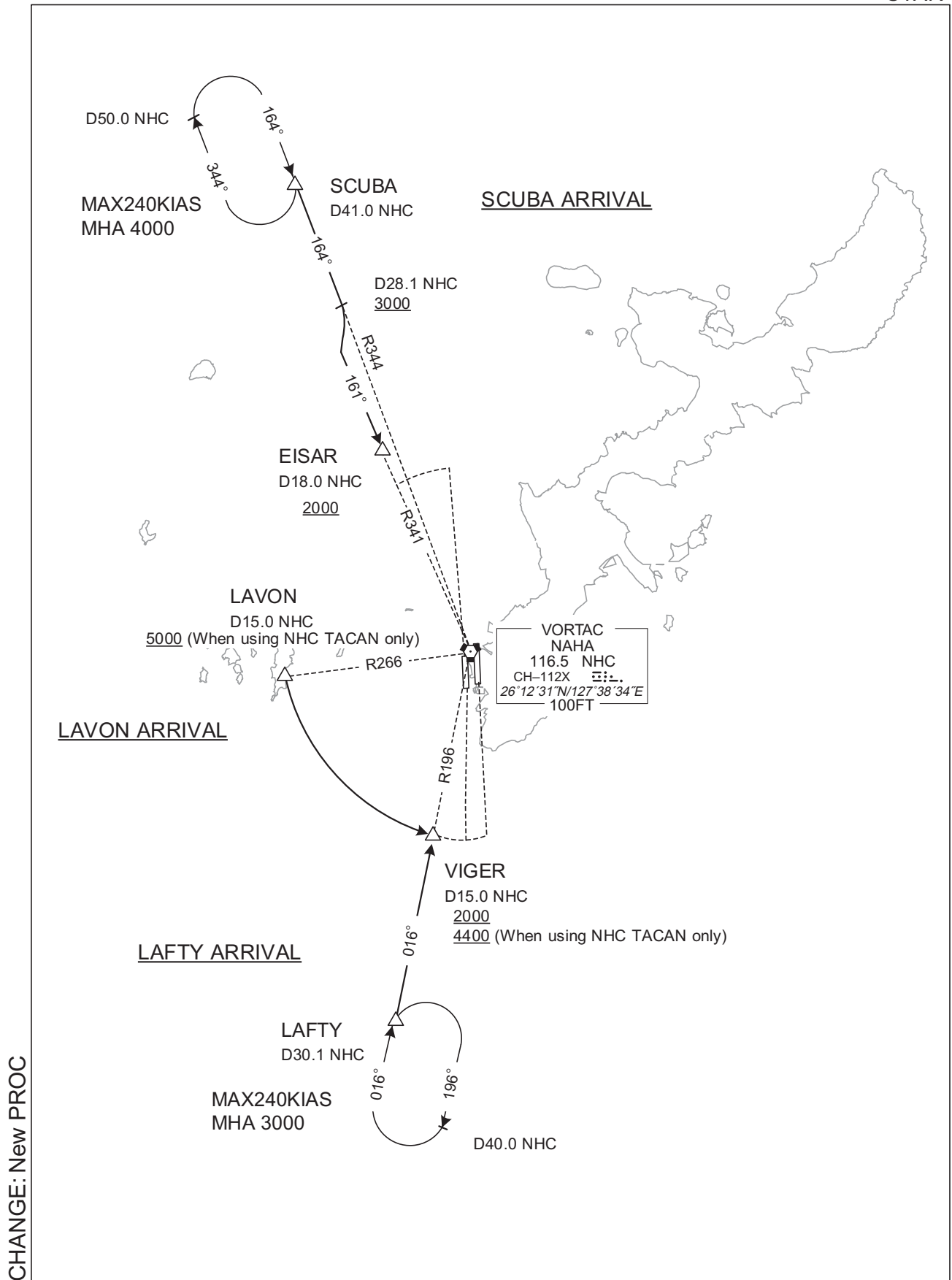

CHANGE: New PROC

STANDARD ARRIVAL CHART-INSTRUMENT

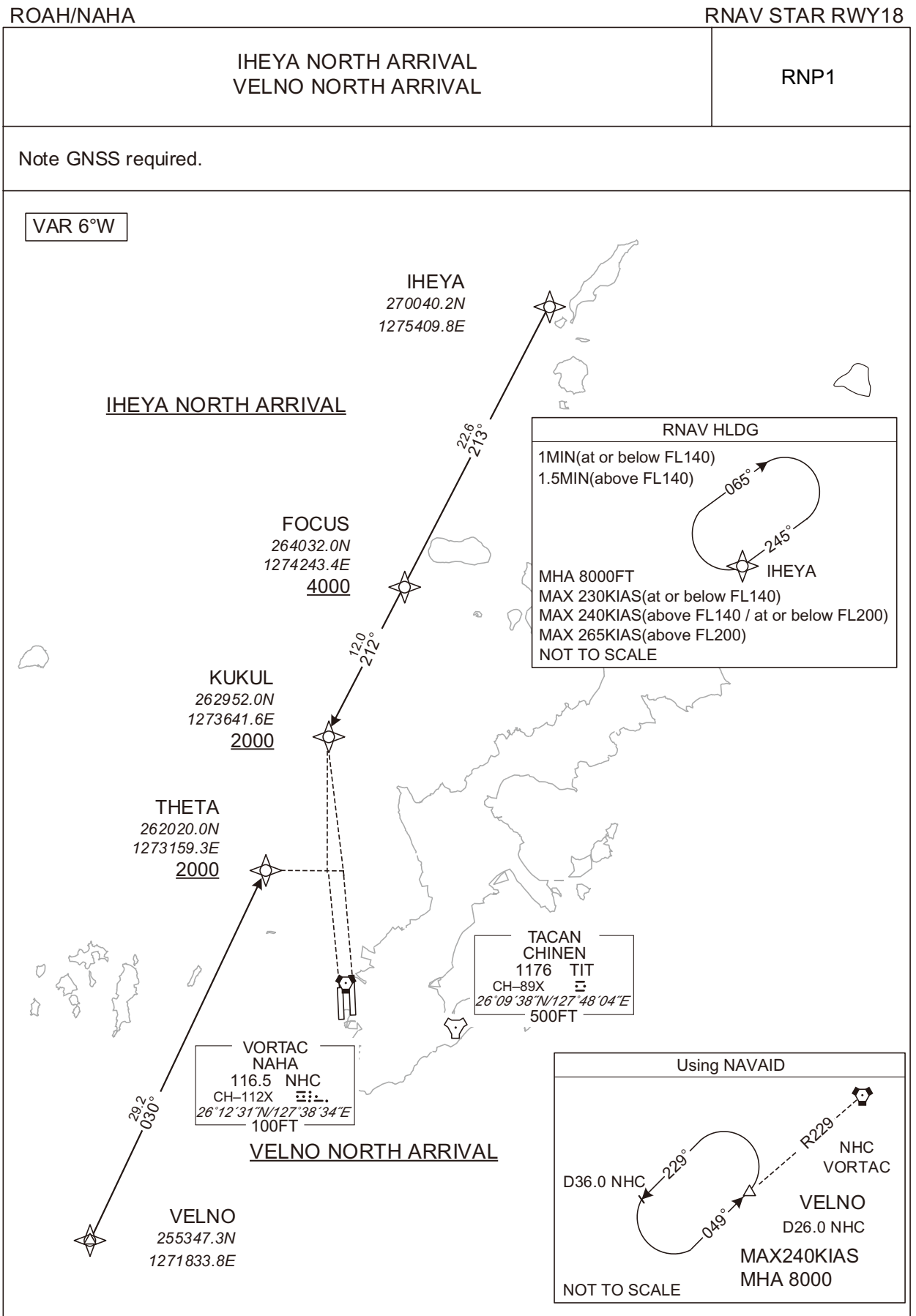



STANDARD ARRIVAL CHART-INSTRUMENT

ROAH / NAHA

RNAV STAR RWY18

IHEYA NORTH ARRIVAL

From IHEYA, to FOCUS at or above 4000FT, to KUKUL at or above 2000FT.

Serial Number	Path Descriptor	Waypoint Identifier	Fly Over	Course °M(°T)	Magnetic Variation	Distance (NM)	Turn Direction	Altitude (FT)	Speed (KIAS)	Vertical Angle	Navigation Specification
001	IF	IHEYA	-	-	-5.6	-	-	-	-	-	RNP1
002	TF	FOCUS	-	213 (206.9)	-5.6	22.6	-	+4000	-	-	RNP1
003	TF	KUKUL	-	212 (206.8)	-5.6	12.0	-	+2000	-	-	RNP1

Path	Waypoint Identifier	Inbound Course °M(°T)	Magnetic Variation	Outbound Time (MIN)	Turn Direction	Minimum Altitude (FT)	Maximum Altitude (FT)	Speed (KIAS)	Navigation Specification
Hold	IHEYA	245 (239.1)	-5.8	1.0 (-14000) 1.5 (+14001)	R	8000	-	-230 (-14000) -240 (14001-20000) -265 (+20001)	RNP1

VELNO NORTH ARRIVAL

From VELNO, to THETA at or above 2000FT.

Serial Number	Path Descriptor	Waypoint Identifier	Fly Over	Course °M(°T)	Magnetic Variation	Distance (NM)	Turn Direction	Altitude (FT)	Speed (KIAS)	Vertical Angle	Navigation Specification
001	IF	VELNO	-	-	-5.6	-	-	-	-	-	RNP1
002	TF	THETA	-	030 (024.4)	-5.6	29.2	-	+2000	-	-	RNP1

CHANGE : Navigation Specification(Basic RNP1 → RNP1).

STANDARD ARRIVAL CHART-INSTRUMENT

ROAH/NAHA

RNAV STAR RWY18

RESORT NORTH ARRIVAL

RNP1

Note 1) GNSS required.  
2) CDO only.

VAR 6°W

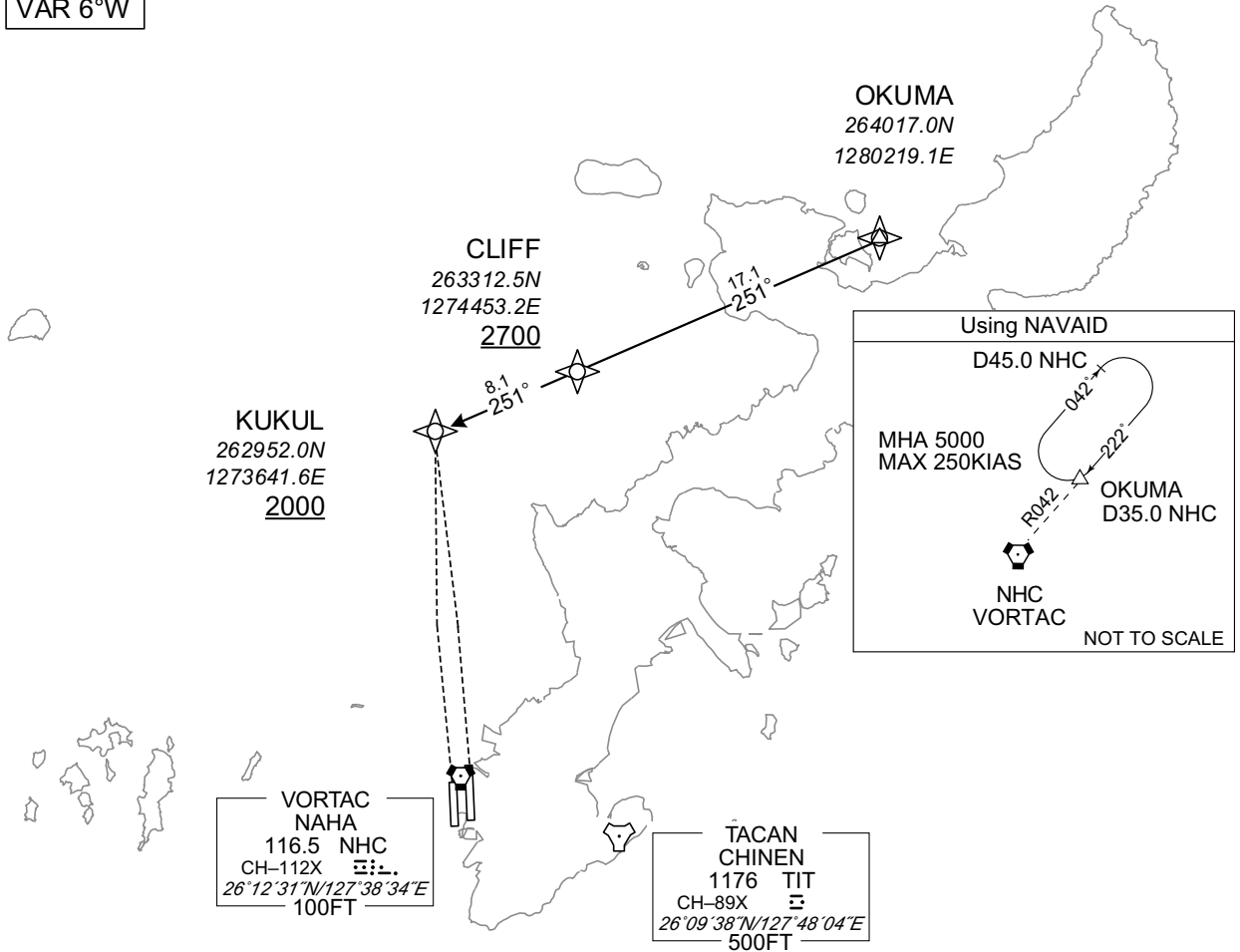

From OKUMA, to CLIFF at or above 2700FT, to KUKUL at or above 2000FT.

CHANGE : Navigation Specification(Basic RNP1 → RNP1).

Serial Number	Path Descriptor	Waypoint Identifier	Fly Over	Course °M(°T)	Magnetic Variation	Distance (NM)	Turn Direction	Altitude (FT)	Speed (KIAS)	Vertical Angle	Navigation Specification
001	IF	OKUMA	-	-	-5.6	-	-	-	-	-	RNP1
002	TF	CLIFF	-	251 (245.7)	-5.6	17.1	-	+2700	-	-	RNP1
003	TF	KUKUL	-	251 (245.5)	-5.6	8.1	-	+2000	-	-	RNP1

STANDARD ARRIVAL CHART-INSTRUMENT

ROAH/NAHA

RNAV STAR RWY18

GUPTI NORTH ARRIVAL  
ENTOK NORTH ARRIVAL

RNP1

Note 1) GNSS required. 2) CDO only.

VAR 6°W

GUPTI NORTH ARRIVAL

GUPTI  
290124.5N  
1280918.7E  
FL200

IHEYA  
270040.2N  
1275409.8E

KUKUL  
262952.0N  
1273641.6E  
2000

ENTOK  
261914.3N  
1245953.8E  
FL170

YEEZY  
262018.1N  
1265032.5E  
2100

THETA  
262020.0N  
1273159.3E  
2000

ENTOK NORTH ARRIVAL

VORTAC  
NAHA  
116.5 NHC  
CH-112X  
26°12'31"N/127°38'34"E  
100FT

TACAN  
CHINEN  
1176 TIT  
CH-89X  
26°09'38"N/127°48'04"E  
500FT

CHANGE : Navigation Specification(Basic RNP1 → RNP1).

STANDARD ARRIVAL CHART-INSTRUMENT

ROAH / NAHA

RNAV STAR RWY18

GUPTI NORTH ARRIVAL

From GUPTI at or above FL200, to IHEYA, to KUKUL at or above 2000FT.

Serial Number	Path Descriptor	Waypoint Identifier	Fly Over	Course °M(°T)	Magnetic Variation	Distance (NM)	Turn Direction	Altitude (FT)	Speed (KIAS)	Vertical Angle	Navigation Specification
001	IF	GUPTI	-	-	-5.6	-	-	+FL200	-	-	RNP1
002	TF	IHEYA	-	192 (186.4)	-5.6	121.6	-	-	-	-	RNP1
003	TF	KUKUL	-	213 (206.9)	-5.6	34.6	-	+2000	-	-	RNP1

ENTOK NORTH ARRIVAL

From ENTOK at or above FL170, to YEEZY at or above 2100FT, to THETA at or above 2000FT.

Serial Number	Path Descriptor	Waypoint Identifier	Fly Over	Course °M(°T)	Magnetic Variation	Distance (NM)	Turn Direction	Altitude (FT)	Speed (KIAS)	Vertical Angle	Navigation Specification
001	IF	ENTOK	-	-	-5.6	-	-	+FL170	-	-	RNP1
002	TF	YEEZY	-	095 (089.0)	-5.6	99.2	-	+2100	-	-	RNP1
003	TF	THETA	-	095 (089.8)	-5.6	37.2	-	+2000	-	-	RNP1

CHANGE : Navigation Specification(Basic RNP1 → RNP1).

STANDARD ARRIVAL CHART-INSTRUMENT

ROAH/NAHA

RNAV STAR RWY36

IHEYA SOUTH ARRIVAL  
VELNO SOUTH ARRIVAL

RNP1

Note GNSS required.

VAR 6°W

**RNAV HLDG**

1MIN(at or below FL140)  
1.5MIN(above FL140)

MHA 8000FT  
MAX 230KIAS(at or below FL140)  
MAX 240KIAS(above FL140 / at or below FL200)  
MAX 265KIAS(above FL200)  
NOT TO SCALE

**Using NAVAID**

D36.0 NHC  
R229  
NHC VORTAC  
VELNO  
D26.0 NHC  
MAX240KIAS  
MHA 8000  
NOT TO SCALE

VORTAC  
NAHA  
116.5 NHC  
CH-112X  
26°12'31"N/127°38'34"E  
100FT

TACAN  
CHINEN  
1176 TIT  
CH-89X  
26°09'38"N/127°48'04"E  
500FT

IHEYA  
270040.2N  
1275409.8E

IHEYA SOUTH ARRIVAL

HASSA  
262334.1N  
1275516.0E  
11000

22.6  
270°

SEIFA  
260303.9N  
1274448.5E  
2000

VELNO SOUTH ARRIVAL

15.7  
081°  
VELNO  
255347.3N  
1271833.8E

VIGER  
255743.9N  
1273526.9E  
2000

CHANGE : Navigation Specification(Basic RNP1 → RNP1).

STANDARD ARRIVAL CHART-INSTRUMENT

ROAH / NAHA

RNAV STAR RWY36

IHEYA SOUTH ARRIVAL

From IHEYA, to HASSA at or above 11000FT, to SEIFA at or above 2000FT.

Serial Number	Path Descriptor	Waypoint Identifier	Fly Over	Course °M(°T)	Magnetic Variation	Distance (NM)	Turn Direction	Altitude (FT)	Speed (KIAS)	Vertical Angle	Navigation Specification
001	IF	IHEYA	-	-	-5.6	-	-	-	-	-	RNP1
002	TF	HASSA	-	184 (178.5)	-5.6	37.1	-	+11000	-	-	RNP1
003	TF	SEIFA	-	210 (204.6)	-5.6	22.6	-	+2000	-	-	RNP1

Path	Waypoint Identifier	Inbound Course °M(°T)	Magnetic Variation	Outbound Time (MIN)	Turn Direction	Minimum Altitude (FT)	Maximum Altitude (FT)	Speed (KIAS)	Navigation Specification
Hold	IHEYA	245 (239.1)	-5.8	1.0 (-14000) 1.5 (+14001)	R	8000	-	-230 (-14000) -240 (14001-20000) -265 (+20001)	RNP1

VELNO SOUTH ARRIVAL

From VELNO, to VIGER at or above 2000FT.

Serial Number	Path Descriptor	Waypoint Identifier	Fly Over	Course °M(°T)	Magnetic Variation	Distance (NM)	Turn Direction	Altitude (FT)	Speed (KIAS)	Vertical Angle	Navigation Specification
001	IF	VELNO	-	-	-5.6	-	-	-	-	-	RNP1
002	TF	VIGER	-	081 (075.4)	-5.6	15.7	-	+2000	-	-	RNP1

CHANGE : Navigation Specification(Basic RNP1 → RNP1).

STANDARD ARRIVAL CHART-INSTRUMENT

ROAH/NAHA

RNAV STAR RWY36

RESORT SOUTH ARRIVAL

RNP1

Note 1) GNSS required.  
2) CDO only.

VAR 6°W

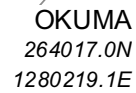
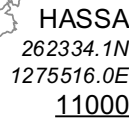
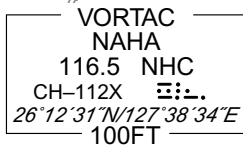
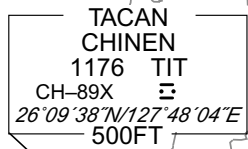
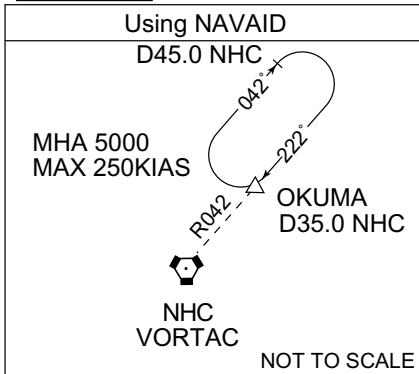

From OKUMA, to HASSA at or above 11000FT, to SEIFA at or above 2000FT.

Serial Number	Path Descriptor	Waypoint Identifier	Fly Over	Course °M(°T)	Magnetic Variation	Distance (NM)	Turn Direction	Altitude (FT)	Speed (KIAS)	Vertical Angle	Navigation Specification
001	IF	OKUMA	-	-	-5.6	-	-	-	-	-	RNP1
002	TF	HASSA	-	206 (200.7)	-5.6	17.9	-	+11000	-	-	RNP1
003	TF	SEIFA	-	210 (204.6)	-5.6	22.6	-	+2000	-	-	RNP1

CHANGE : Navigation Specification(Basic RNP1 → RNP1).

STANDARD ARRIVAL CHART-INSTRUMENT

ROAH/NAHA

RNAV STAR RWY36

GUPTI SOUTH ARRIVAL  
ENTOK SOUTH ARRIVAL

RNP1

Note 1) GNSS required. 2) CDO only.

VAR 6°W

CHANGE : Navigation Specification(Basic RNP1 → RNP1).

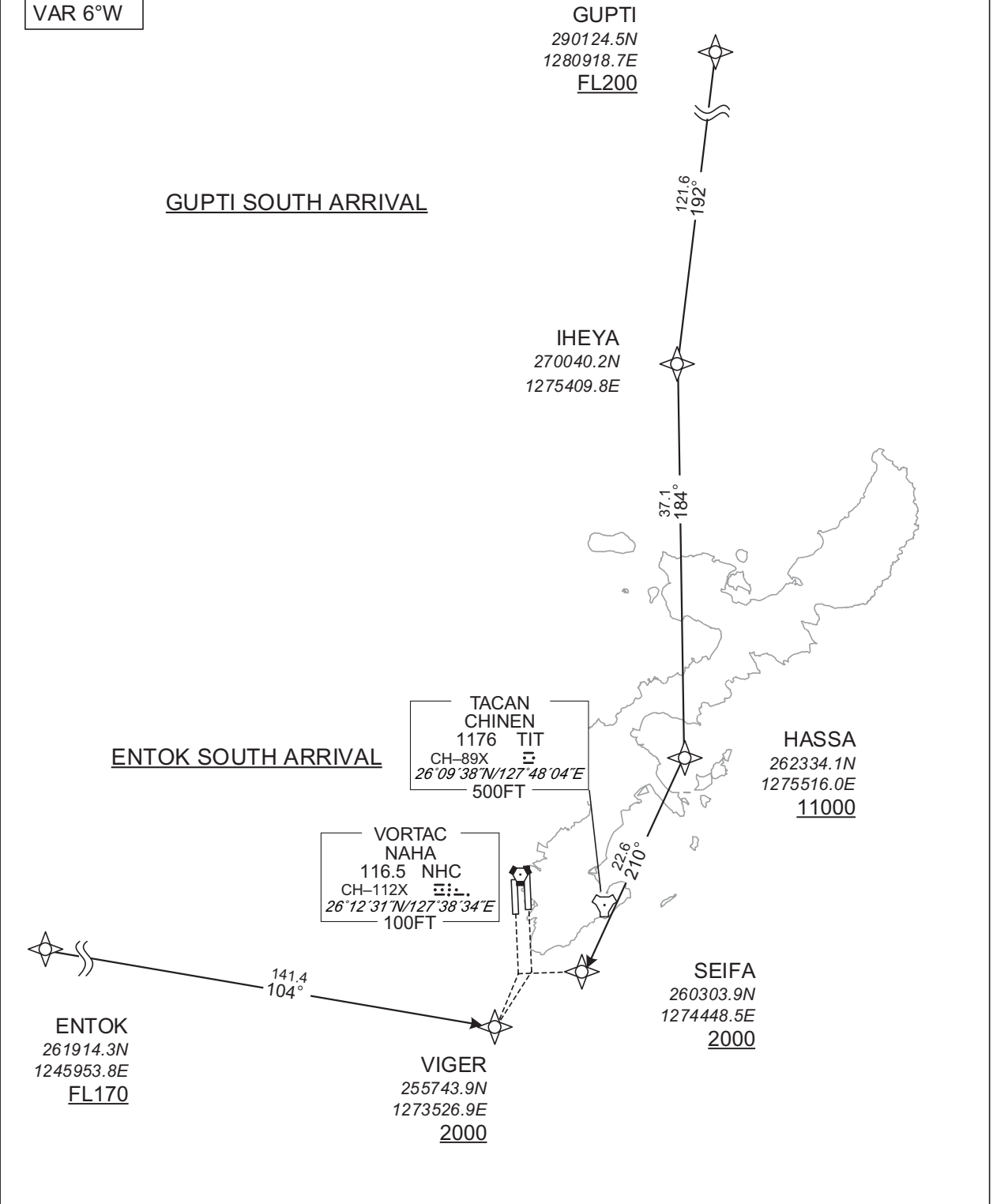



STANDARD ARRIVAL CHART-INSTRUMENT

ROAH / NAHA

RNAV STAR RWY36

GUPTI SOUTH ARRIVAL

From GUPTI at or above FL200, to IHEYA, to HASSA at or above 11000FT, to SEIFA at or above 2000FT.

Serial Number	Path Descriptor	Waypoint Identifier	Fly Over	Course °M(°T)	Magnetic Variation	Distance (NM)	Turn Direction	Altitude (FT)	Speed (KIAS)	Vertical Angle	Navigation Specification
001	IF	GUPTI	-	-	-5.6	-	-	+FL200	-	-	RNP1
002	TF	IHEYA	-	192 (186.4)	-5.6	121.6	-	-	-	-	RNP1
003	TF	HASSA	-	184 (178.5)	-5.6	37.1	-	+11000	-	-	RNP1
004	TF	SEIFA	-	210 (204.6)	-5.6	22.6	-	+2000	-	-	RNP1

ENTOK SOUTH ARRIVAL

From ENTOK at or above FL170, to VIGER at or above 2000FT.

Serial Number	Path Descriptor	Waypoint Identifier	Fly Over	Course °M(°T)	Magnetic Variation	Distance (NM)	Turn Direction	Altitude (FT)	Speed (KIAS)	Vertical Angle	Navigation Specification
001	IF	ENTOK	-	-	-5.6	-	-	+FL170	-	-	RNP1
002	TF	VIGER	-	104 (098.2)	-5.6	141.4	-	+2000	-	-	RNP1

CHANGE : Navigation Specification(Basic RNP1 → RNP1).

INSTRUMENT APPROACH CHART

ROAH / NAHA

ILS Z or LOC Z RWY36R

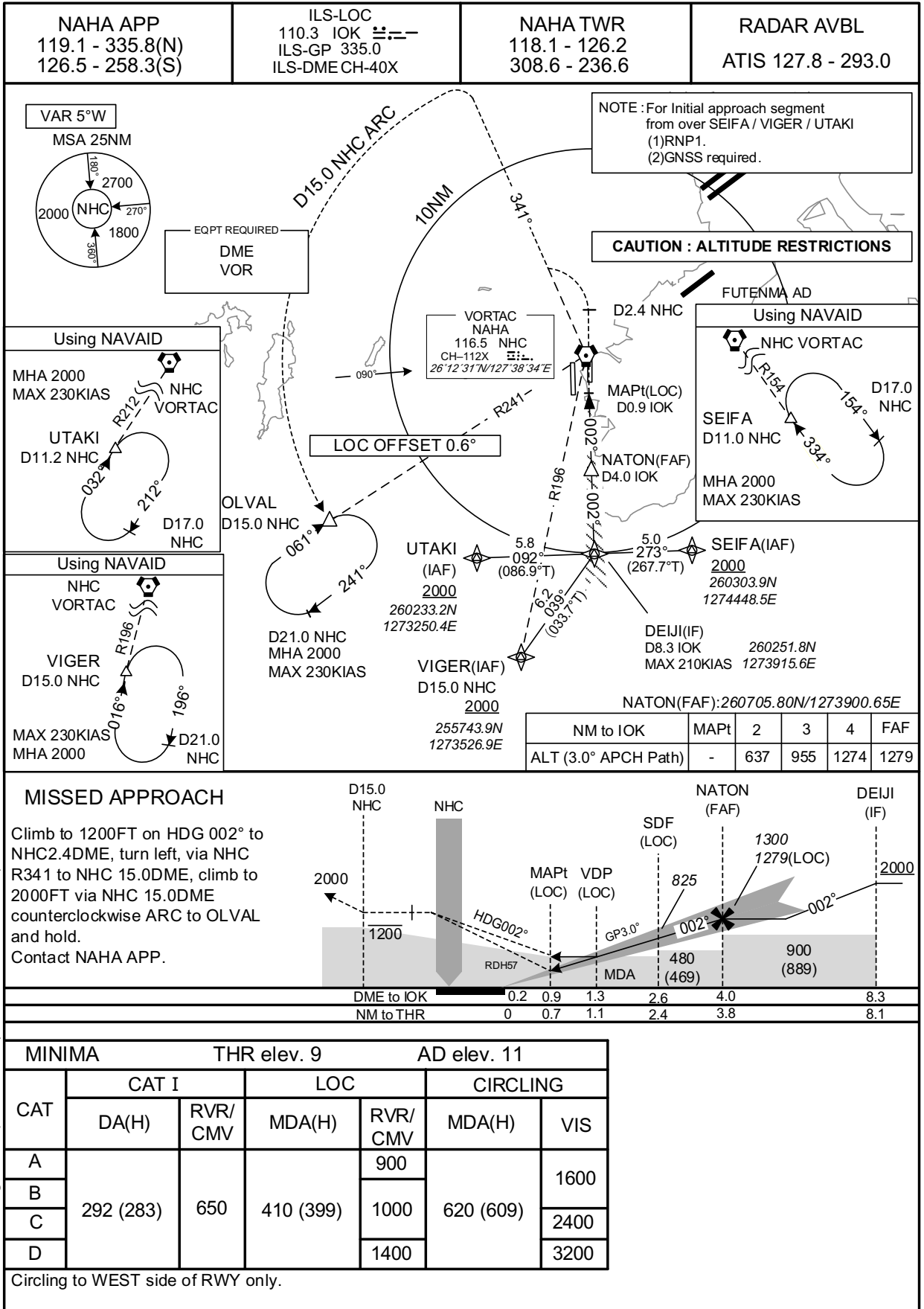

CHANGE : Navigation Specification(Basic RNP1 → RNP1).

INSTRUMENT APPROACH CHART

ROAH / NAHA

ILS Y or LOC Y RWY36R

<b>NAHA APP</b> 119.1 - 335.8(N) 126.5 - 258.3(S)	<b>ILS-LOC</b> 110.3 IOK ILS-GP 335.0 ILS-DME CH-40X	<b>NAHA TWR</b> 118.1 - 126.2 308.6 - 236.6	<b>RADAR AVBL</b> ATIS 127.8 - 293.0
---	---	---	---

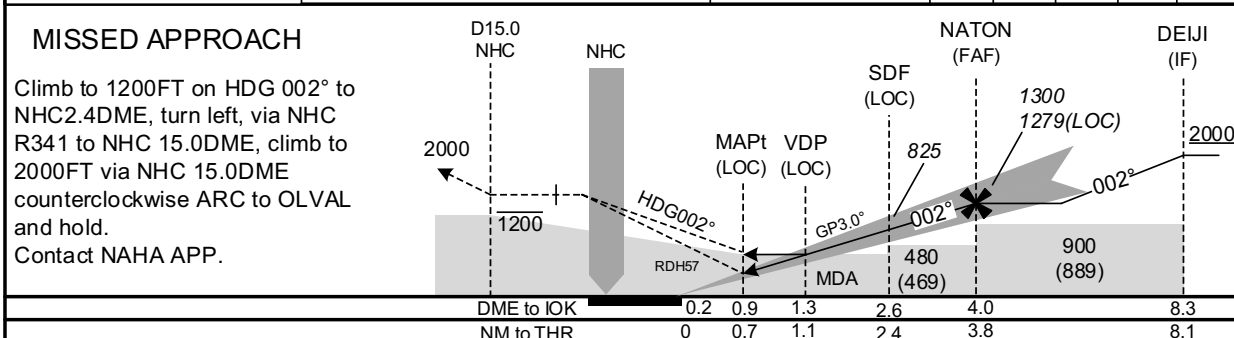
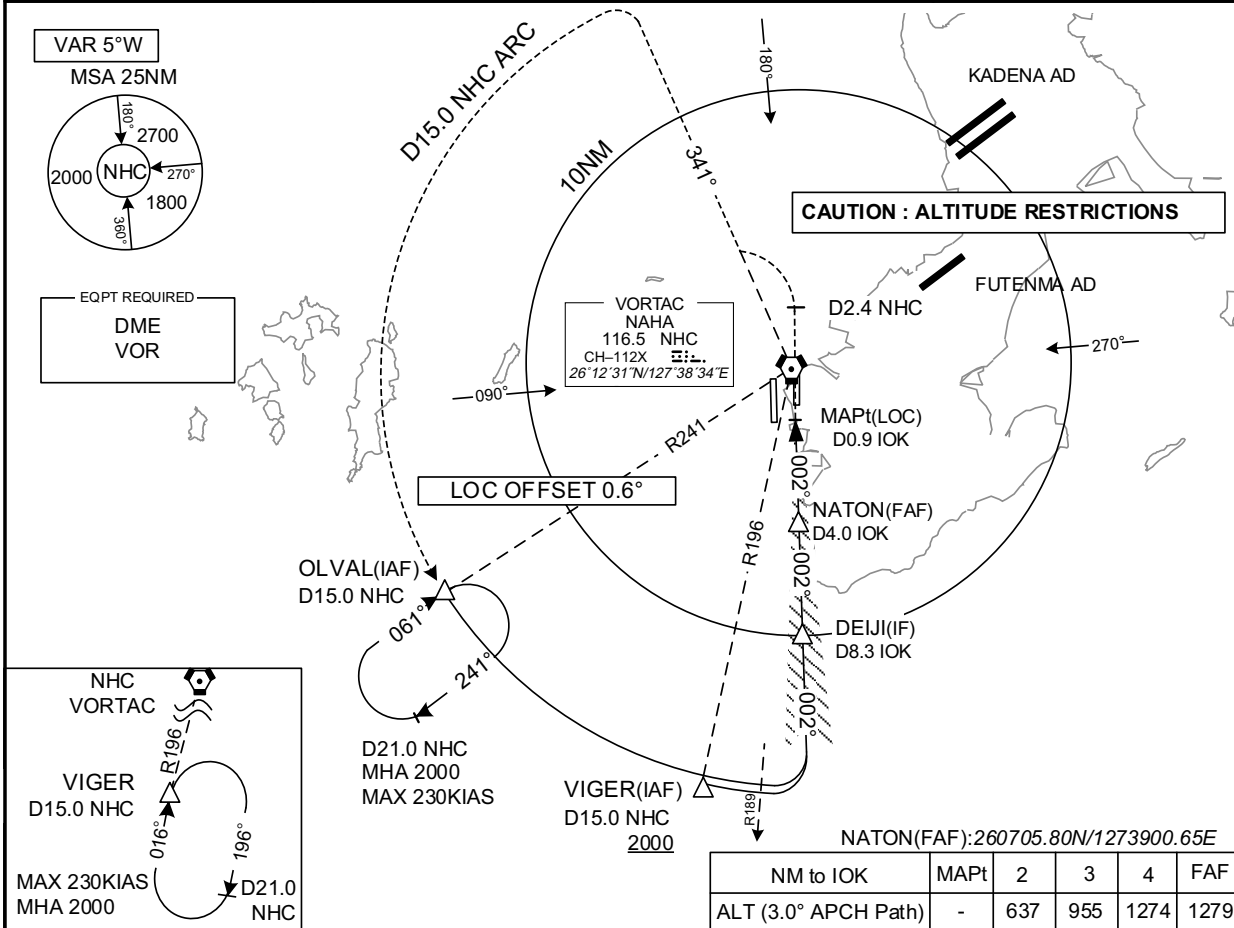

DME to IOK	0.2	0.9	1.3	2.6	4.0	8.3
NM to THR	0	0.7	1.1	2.4	3.8	8.1

MINIMA		THR elev. 9		AD elev. 11		
CAT	CAT I		LOC		CIRCLING	
	DA(H)	RVR/CMV	MDA(H)	RVR/CMV	MDA(H)	VIS
A	292 (283)	650	410 (399)	900	620 (609)	1600
B				1000		
C				1400		
D				3200		

Circling to WEST side of RWY only.

CHANGE : Description of VAR.

INSTRUMENT APPROACH CHART

ROAH / NAHA

ILS X or LOC X RWY36R

<p>NAHA APP 119.1 - 335.8(N) 126.5 - 258.3(S)</p>	<p>ILS-LOC 110.3 IOK </p> <p>ILS-GP 335.0</p> <p>ILS-DME CH-40X</p>	<p>NAHA TWR 118.1 - 126.2 308.6 - 236.6</p>	<p>RADAR AVBL ATIS 127.8 - 293.0</p>
---	---	---	--

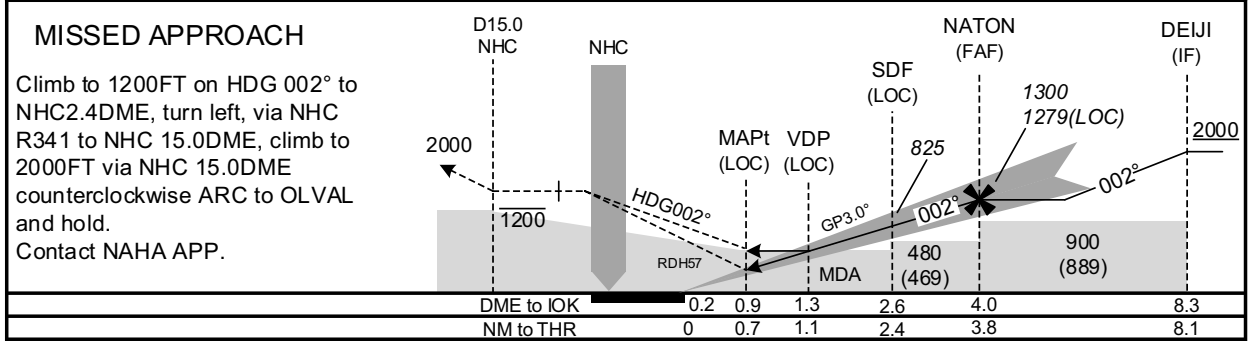
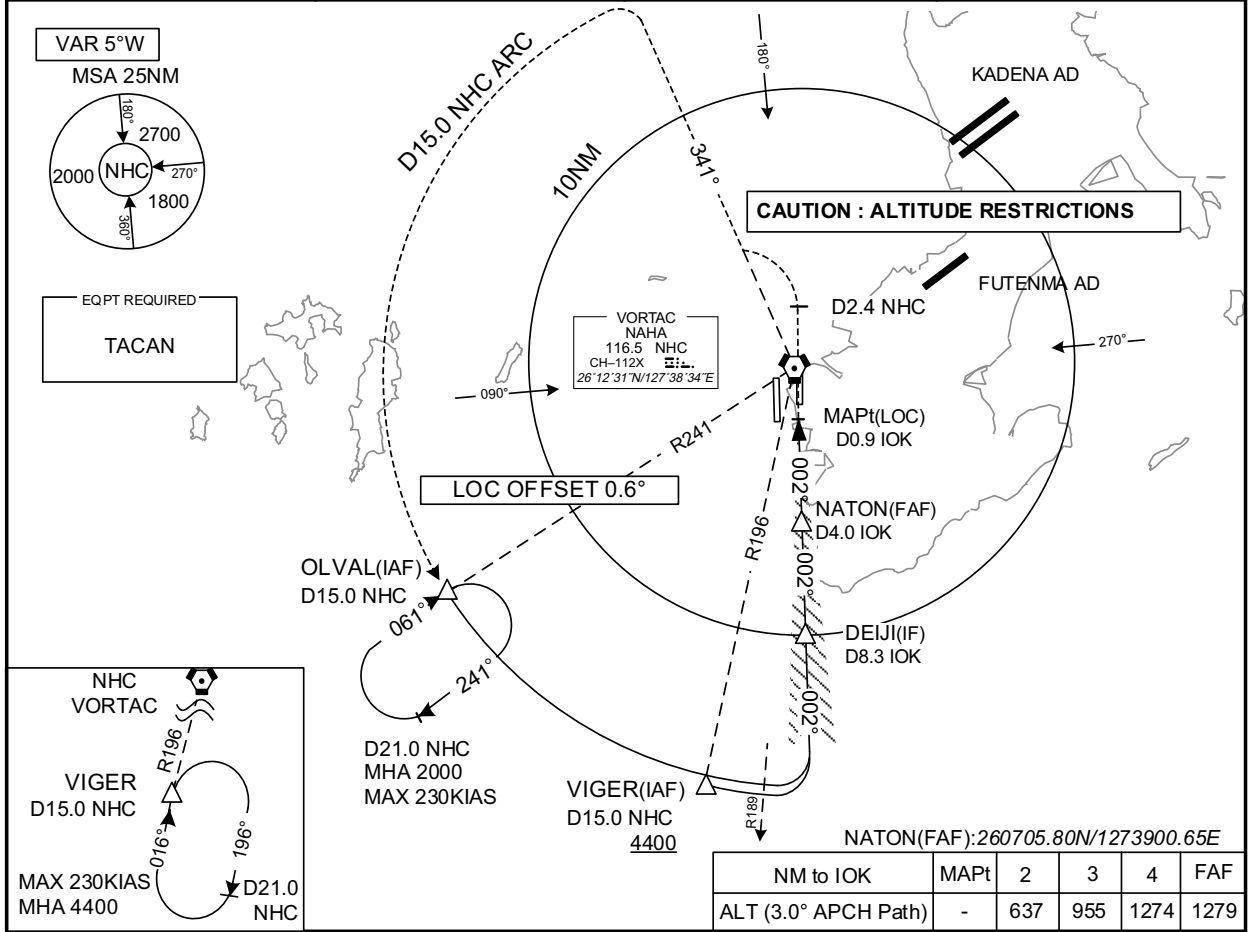

MINIMA		THR elev. 9		AD elev. 11		
CAT	CAT I		LOC		CIRCLING	
	DA(H)	RVR/CMV	MDA(H)	RVR/CMV	MDA(H)	VIS
A	292 (283)	650	410 (399)	900	620 (609)	1600
B				1000		2400
C				1400		3200
D						

CHANGE : Description of VAR.

Circling to WEST side of RWY only.

INSTRUMENT APPROACH CHART

ROAH / NAHA

ILS Z or LOC Z RWY36L

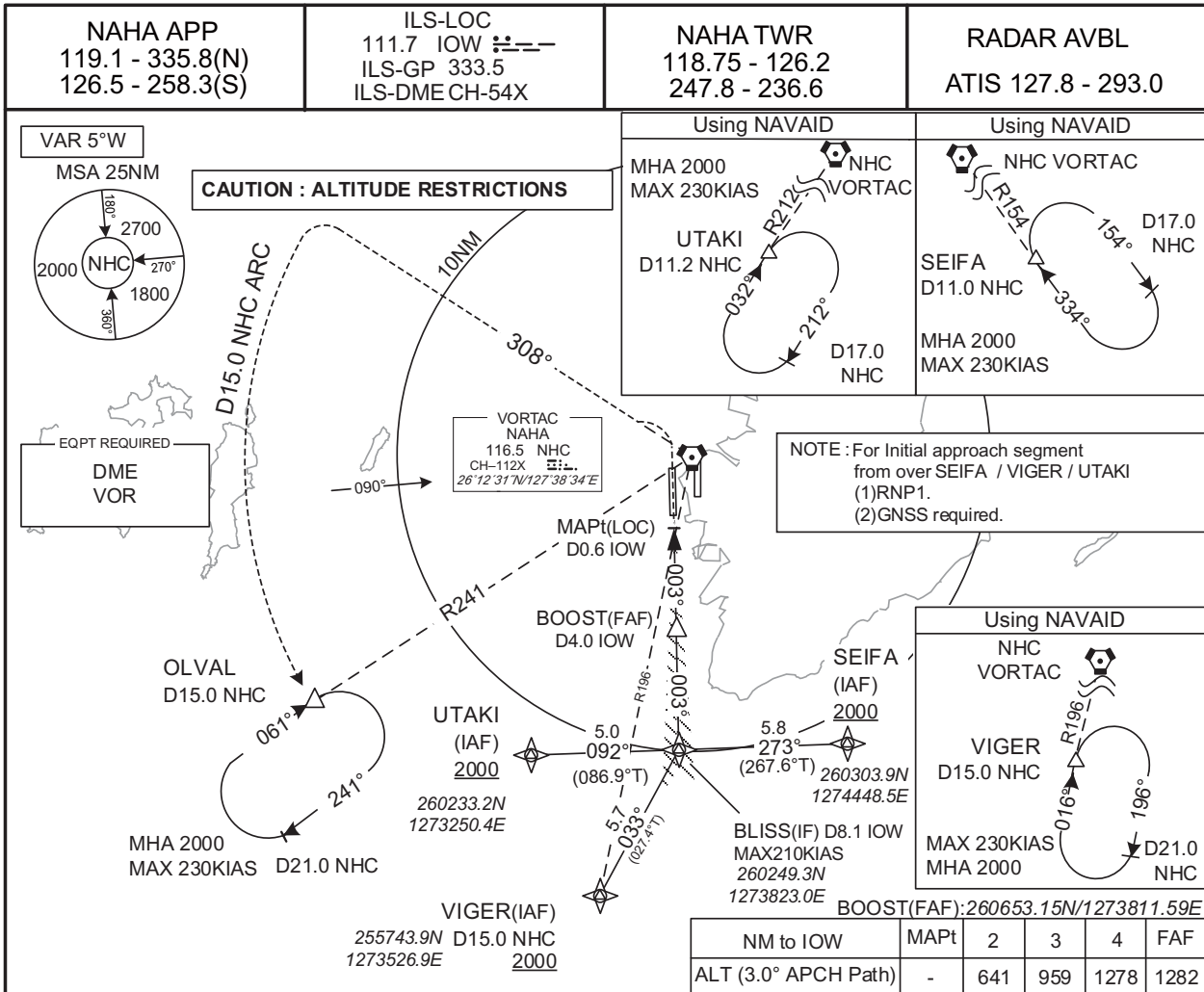

CHANGE : Navigation Specification(Basic RNP1 → RNP1).

**MISSED APPROACH**

Turn left, climb to 1200FT via NHC  
 R 308 to NHC 8.5DME, climb to 2000FT  
 via NHC R308 to NHC 15.0DME, via  
 NHC 15.0DME counterclockwise ARC  
 to OLVAL and hold.  
 Cross NHC R308/12.0DME at or above  
 1400FT.  
 Contact NAHA APP.

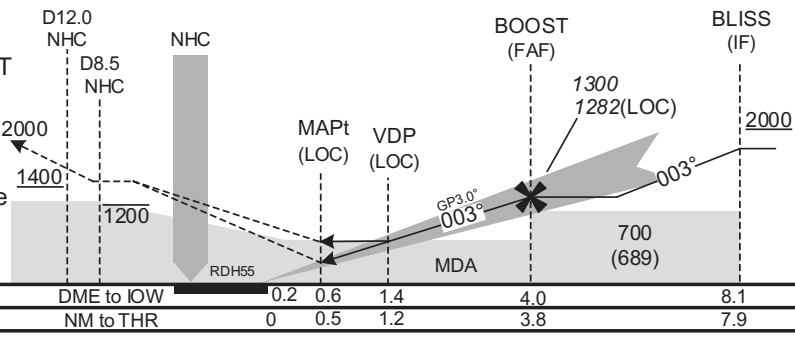

MINIMA		THR elev. 14		AD elev. 11		
CAT	CAT I		LOC		CIRCLING	
	DA(H)	RVR/CMV	MDA(H)	RVR/CMV	MDA(H)	VIS
A				900		1600
B					620 (609)	
C	214 (200)	550	430 (419)	1000		2400
D				1400		3200

Circling to WEST side of RWY only.

INSTRUMENT APPROACH CHART

ROAH / NAHA

ILS Y or LOC Y RWY36L

<p>NAHA APP 119.1 - 335.8(N) 126.5 - 258.3(S)</p>	<p>ILS-LOC 111.7 IOW</p> <p>ILS-GP 333.5</p> <p>ILS-DME CH-54X</p>	<p>NAHA TWR 118.75 - 126.2 247.8 - 236.6</p>	<p>RADAR AVBL ATIS 127.8 - 293.0</p>
---	--	--	--

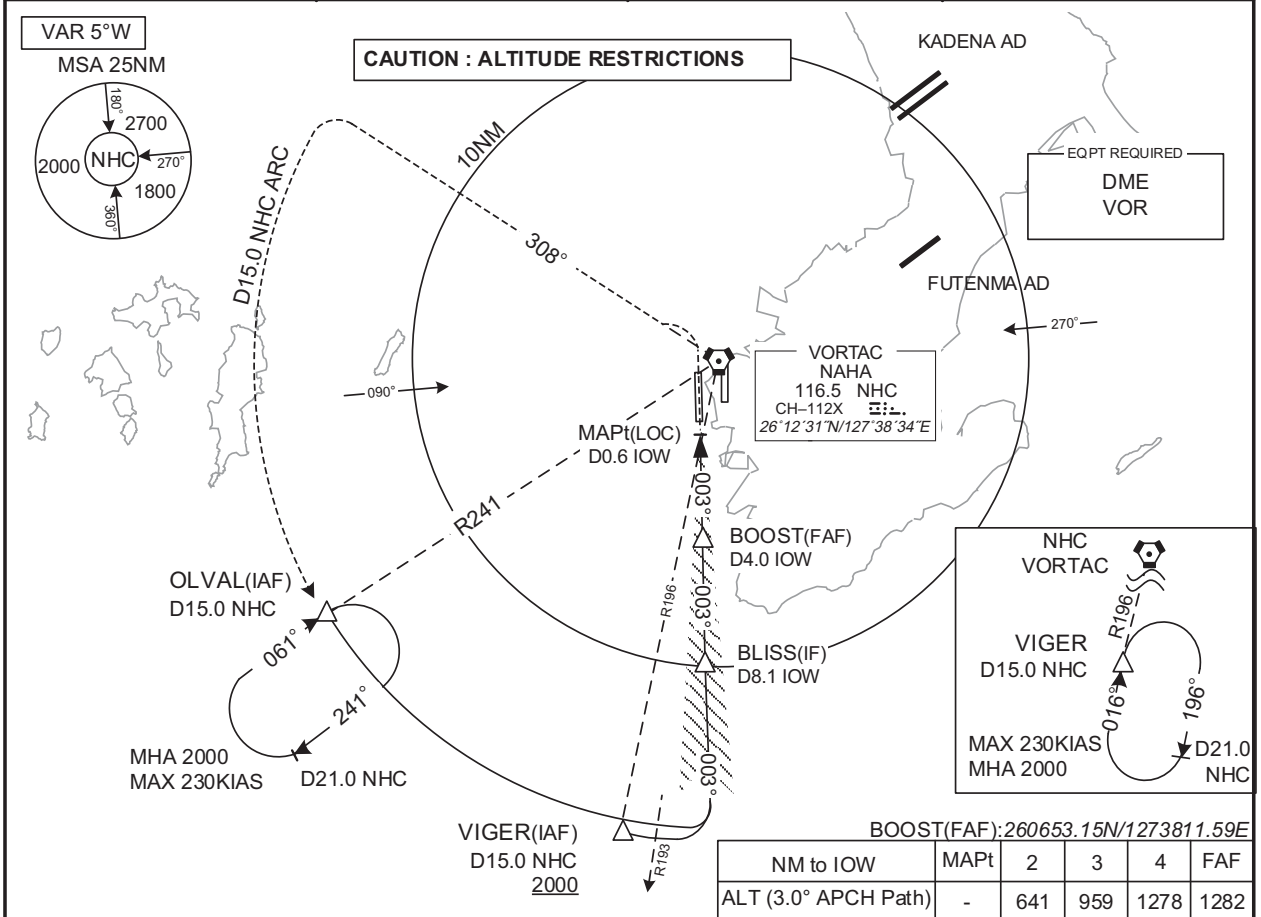

MISSED APPROACH

Turn left, climb to 1200FT via NHC  
R308 to NHC8.5DME, climb to 2000FT  
via NHC R308 to NHC 15.0DME, via  
NHC 15.0DME counterclockwise ARC  
to OLVAL and hold.  
Cross NHC R308/12.0DME at or above  
1400FT.  
Contact NAHA APP.

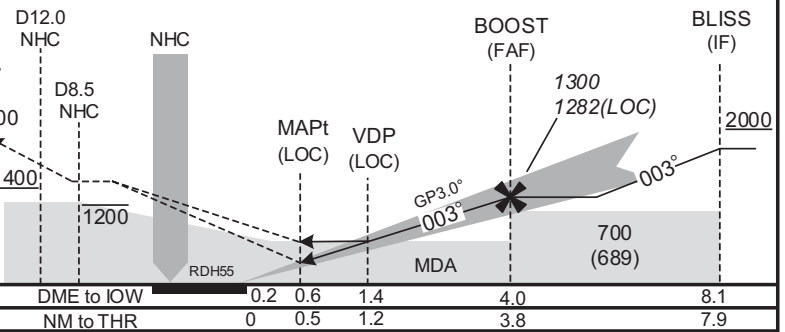

CAT	THR elev. 14		AD elev. 11				
	CAT I	LOC	CIRCLING				
	DA(H)	RVR/CMV	MDA(H)	RVR/CMV	MDA(H)	VIS	
A	214 (200)	550	430 (419)	900	620 (609)	1600	
B				1000			
C				1400			2400
D				3200			

CHANGE : Description of VAR.

Circling to WEST side of RWY only.

INSTRUMENT APPROACH CHART

ROAH / NAHA

ILS X or LOC X RWY36L

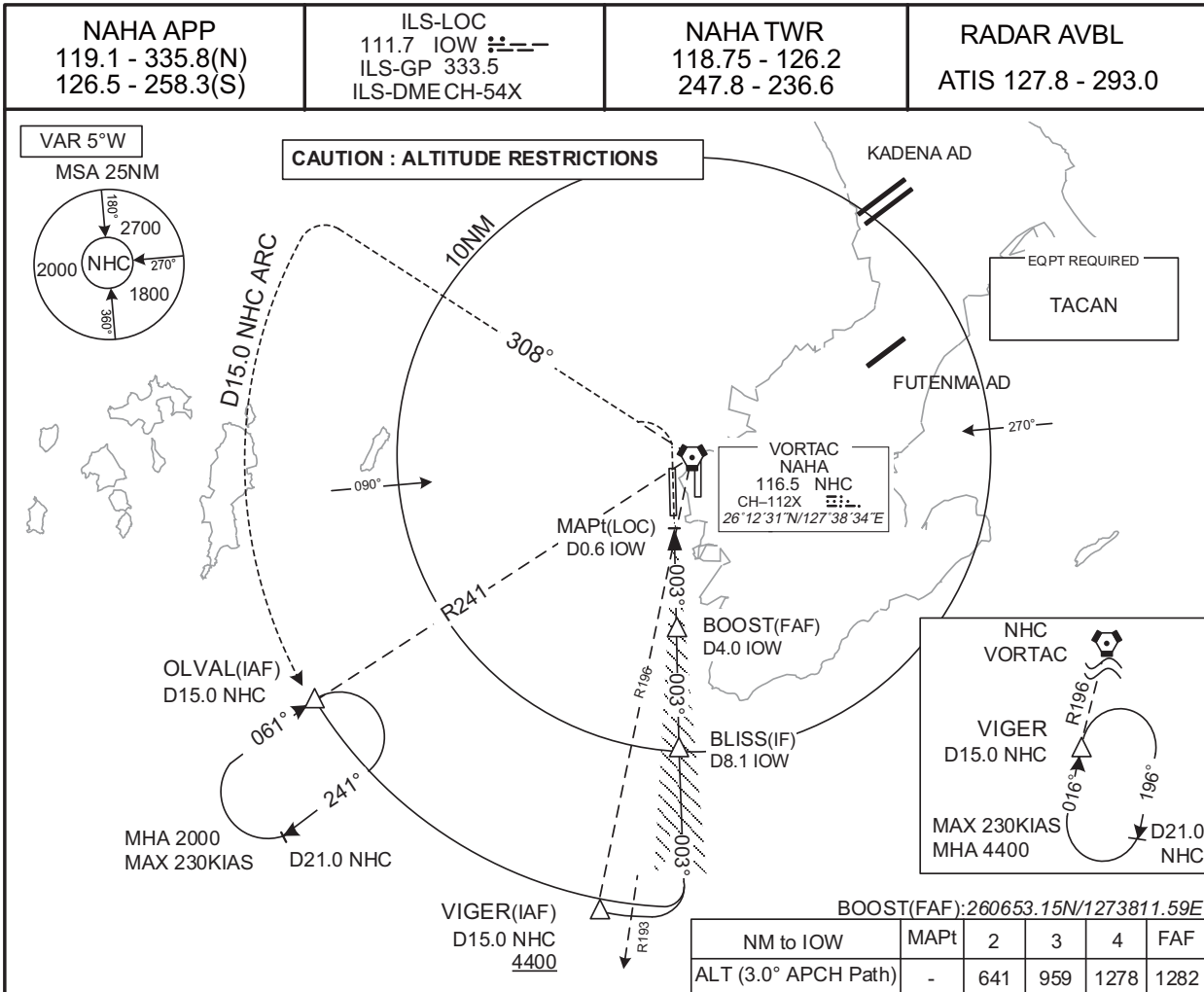

**MISSED APPROACH**

Turn left, climb to 1200FT via NHC  
 R308 to NHC8.5DME, climb to 2000FT  
 via NHC R308 to NHC 15.0DME, via  
 NHC 15.0DME counterclockwise ARC 2000  
 to OLVAL and hold.  
 Cross NHC R308/12.0DME at or above  
 1400FT.  
 Contact NAHA APP.

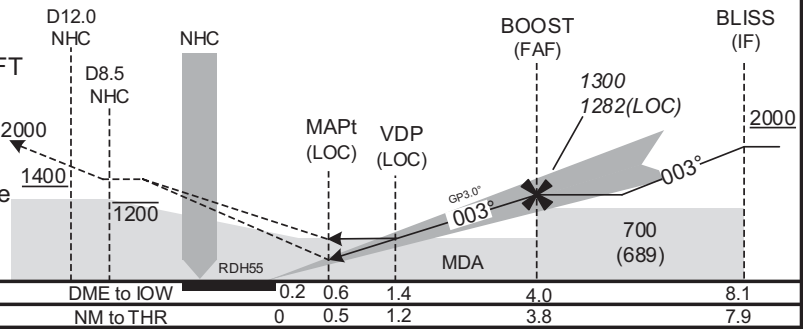

MINIMA		THR elev. 14		AD elev. 11		
CAT	CAT I		LOC		CIRCLING	
	DA(H)	RVR/ CMV	MDA(H)	RVR/ CMV	MDA(H)	VIS
A	214 (200)	550	430 (419)	900	620 (609)	1600
B				1000		2400
C				1400		3200
D						

Circling to WEST side of RWY only.

CHANGE : Description of VAR.



INSTRUMENT APPROACH CHART

ROAH / NAHA ILS or LOC RWY18R

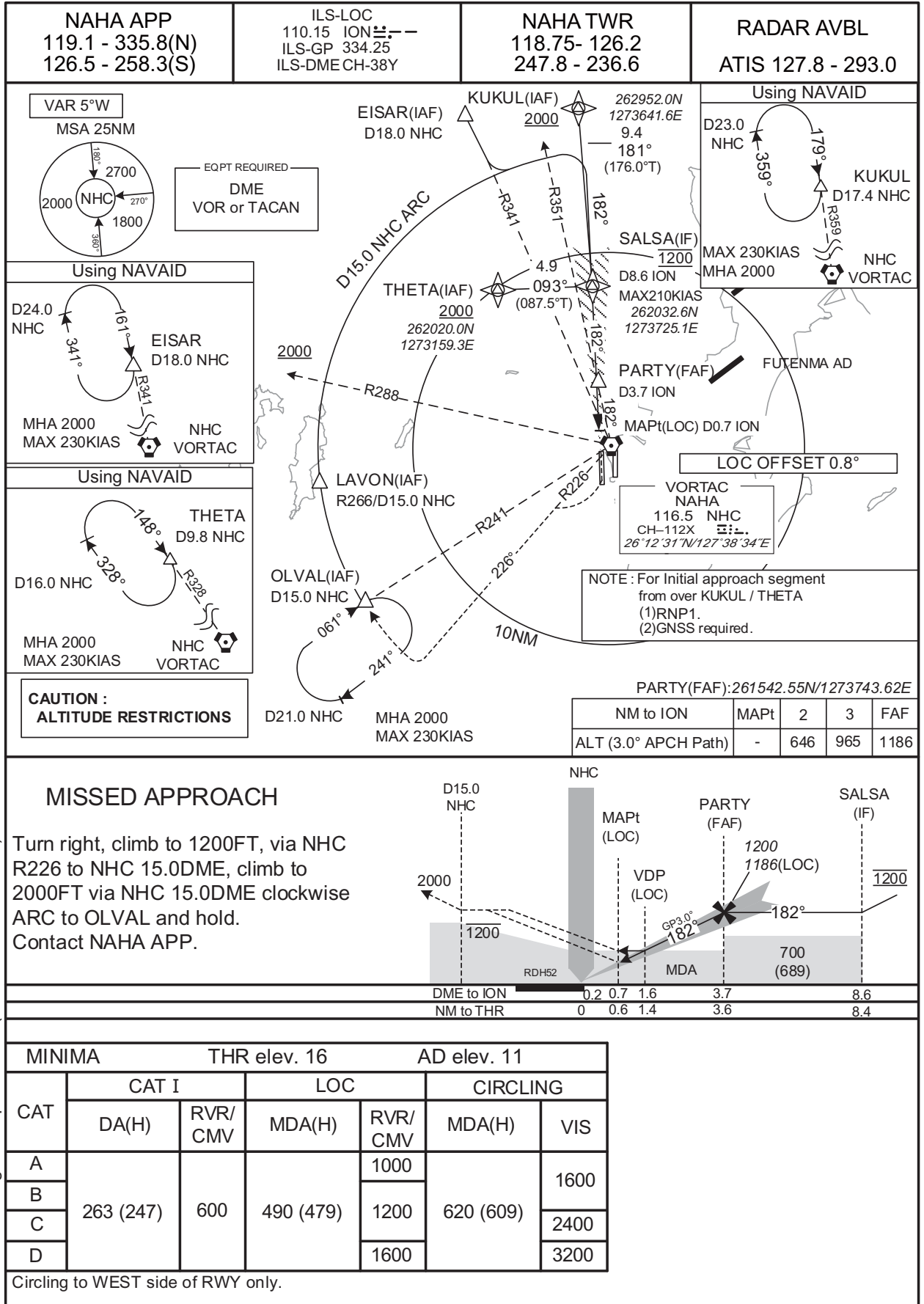

CHANGE : Navigation Specification(Basic RNP1 → RNP1).



INSTRUMENT APPROACH CHART

ROAH / NAHA

RNP RWY36R

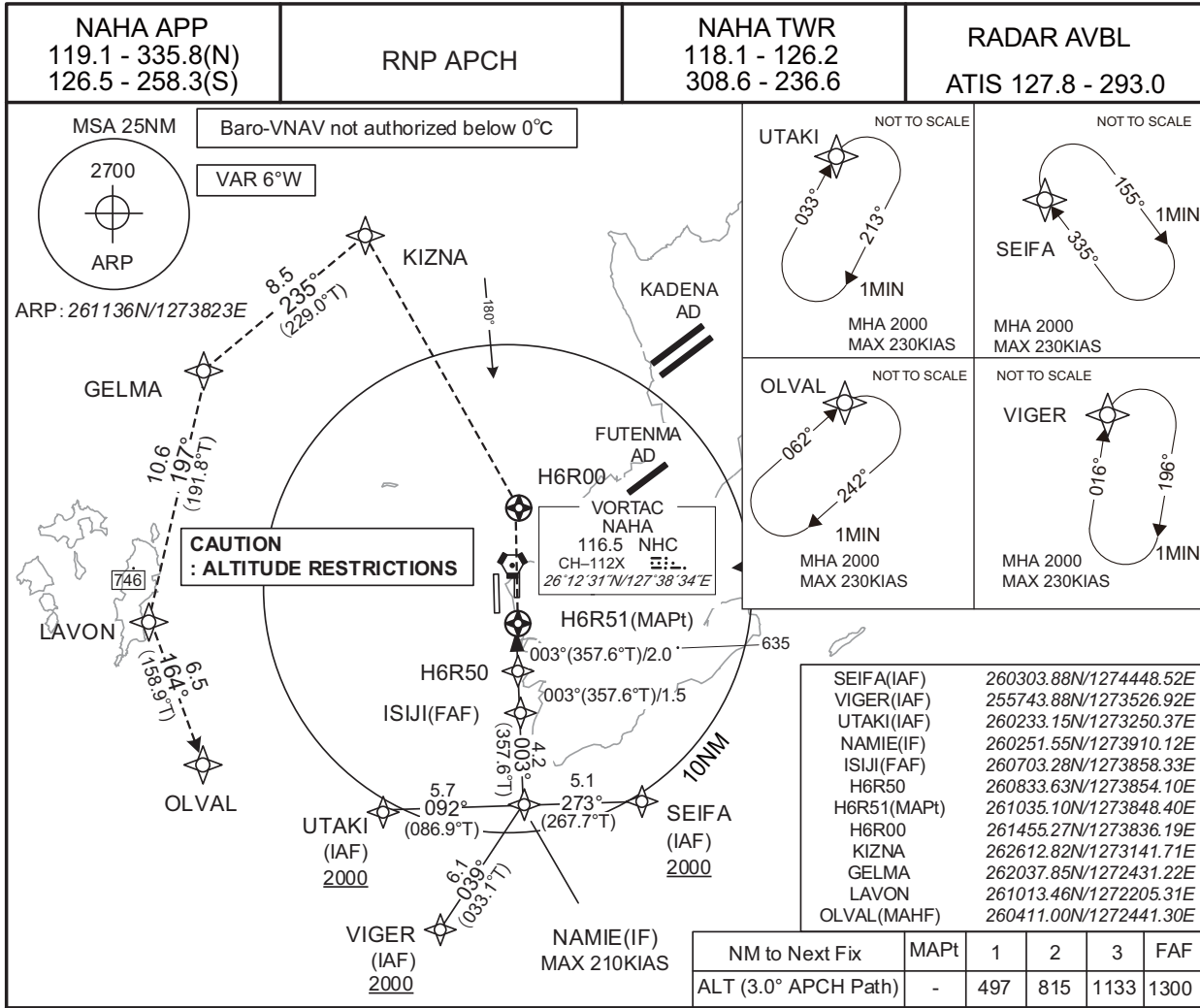

MISSED APPROACH

Direct to H6R00, turn left direct to KIZNA at or below 1200FT, to GELMA, to LAVON, to OLVAL and hold at 2000FT.

Contact NAHA APP.

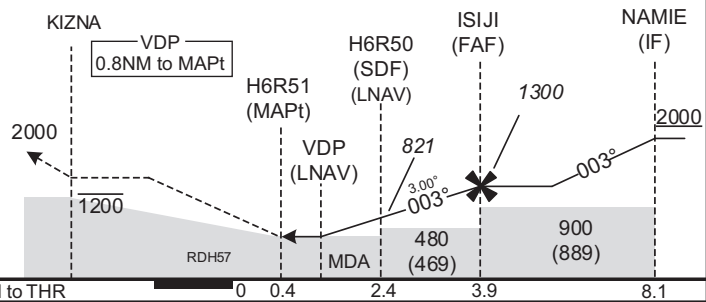

CHANGE : Description of VAR.

MINIMA		THR elev. 9		AD elev. 11		
CAT	LNAV/VNAV		LNAV		CIRCLING	
	DA(H)	RVR/CMV	MDA(H)	RVR/CMV	MDA(H)	VIS
A	410 (401)	900	410 (399)	900	620 (609)	1600
B		1000		2400		
C		1400		1400		3200
D						

Circling to WEST side of RWY only.

INSTRUMENT APPROACH CHART

ROAH / NAHA

RNP RWY36L

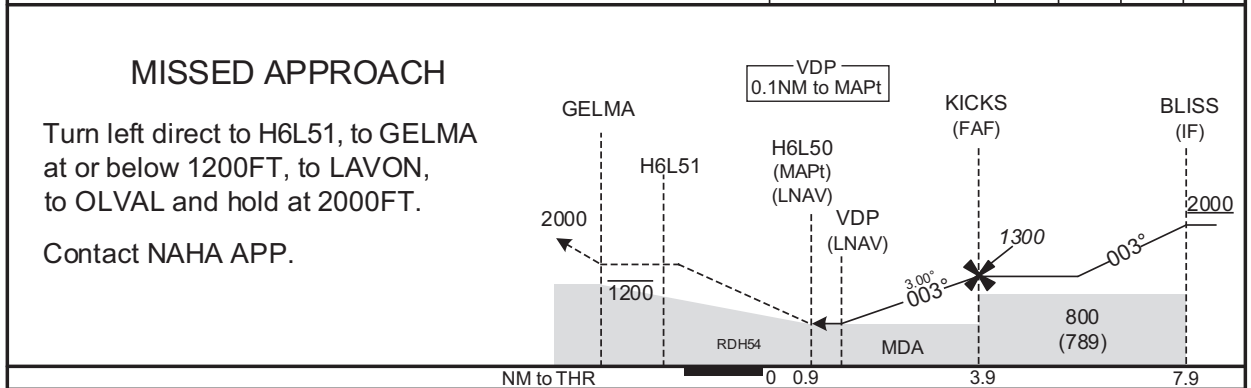
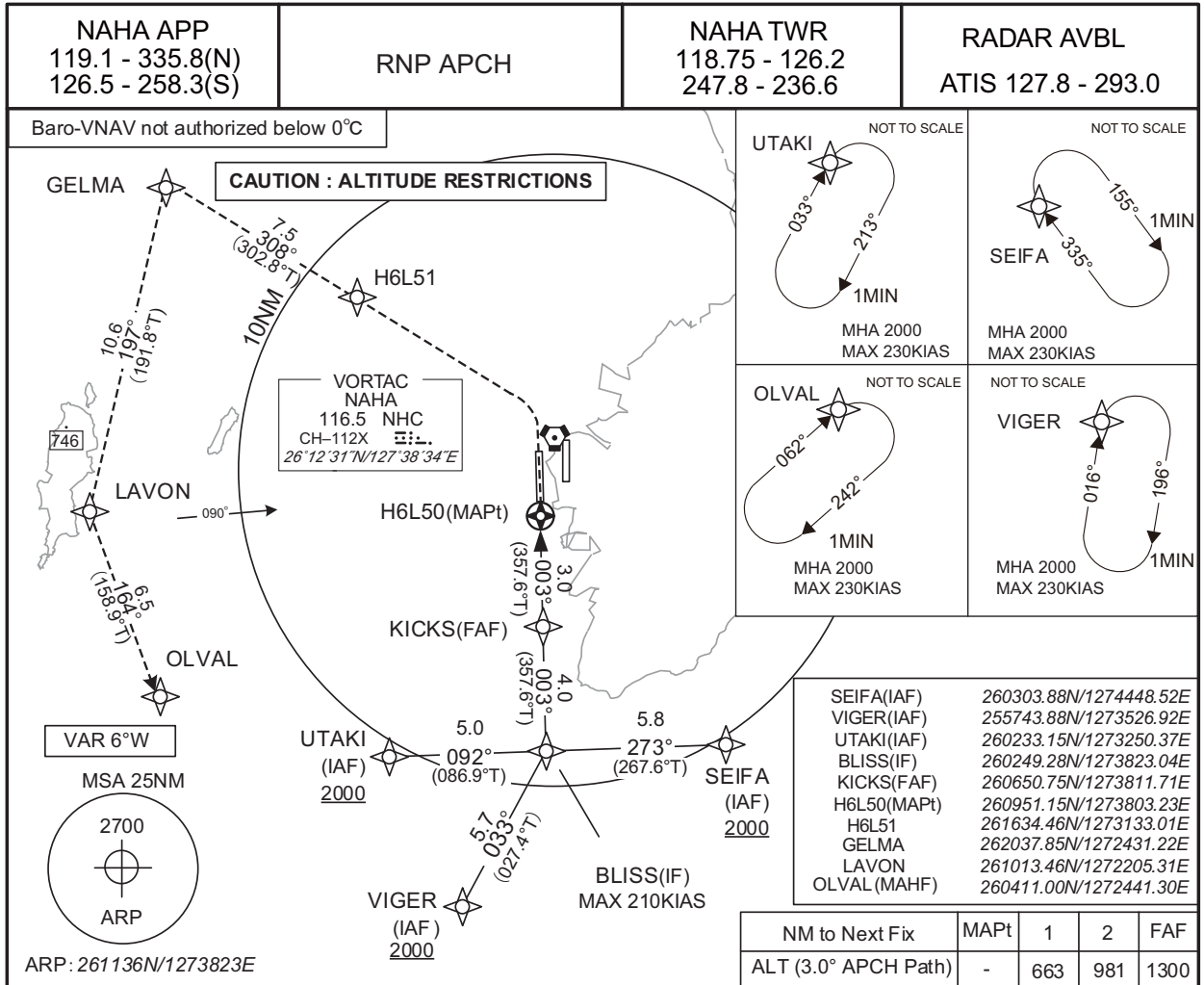

MINIMA		THR elev. 14		AD elev. 11		
CAT	LNAV/VNAV		LNAV		CIRCLING	
	DA(H)	RVR/CMV	MDA(H)	RVR/CMV	MDA(H)	VIS
A	370 (356)	900	370 (359)	900	620 (609)	1600
B		1000		1000		2400
C		1400		1400		3200
D						

CHANGE : Description of VAR.

Circling to WEST side of RWY only.

INSTRUMENT APPROACH CHART

ROAH / NAHA

RNP RWY18R

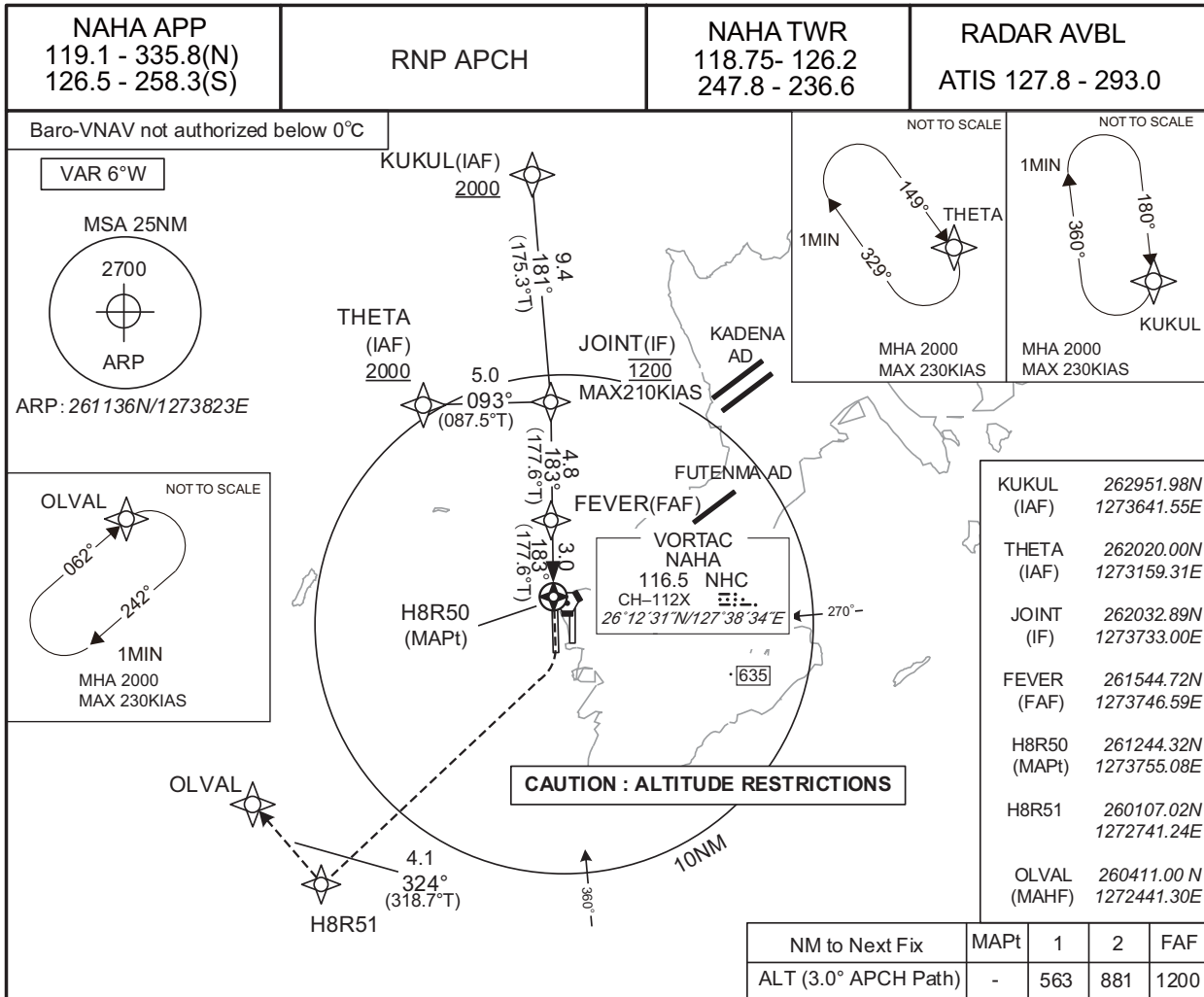

**MISSED APPROACH**

Turn right direct to H8R51 at or below 1200FT, to OLVAL and hold at 2000FT.  
Contact NAHA APP.

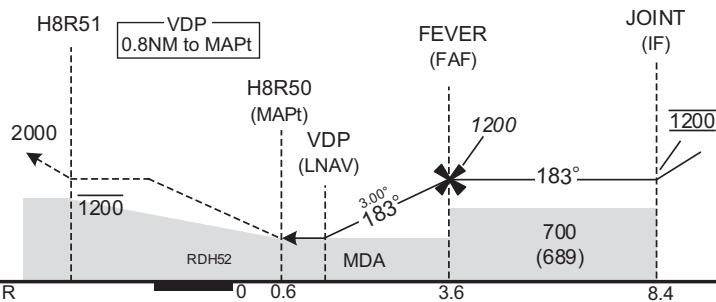

MINIMA		THR elev. 16		AD elev. 11		
CAT	LNAV/VNAV		LNAV		CIRCLING	
	DA(H)	RVR/CMV	MDA(H)	RVR/CMV	MDA(H)	VIS
A		1000		1000		1600
B	490 (474)	1200	490 (479)	1200	620 (609)	2400
C						
D						

Circling to WEST side of RWY only.

CHANGE : Description of VAR.

INSTRUMENT APPROACH CHART

ROAH / NAHA

RNP RWY18L

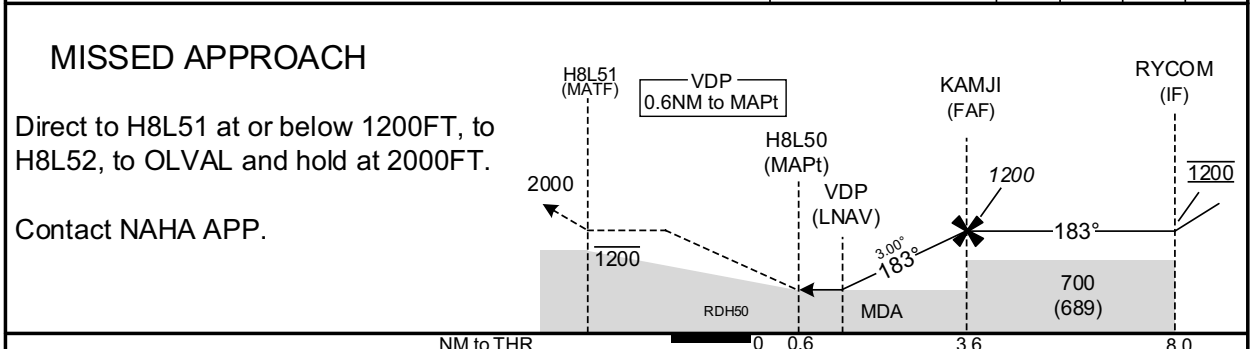
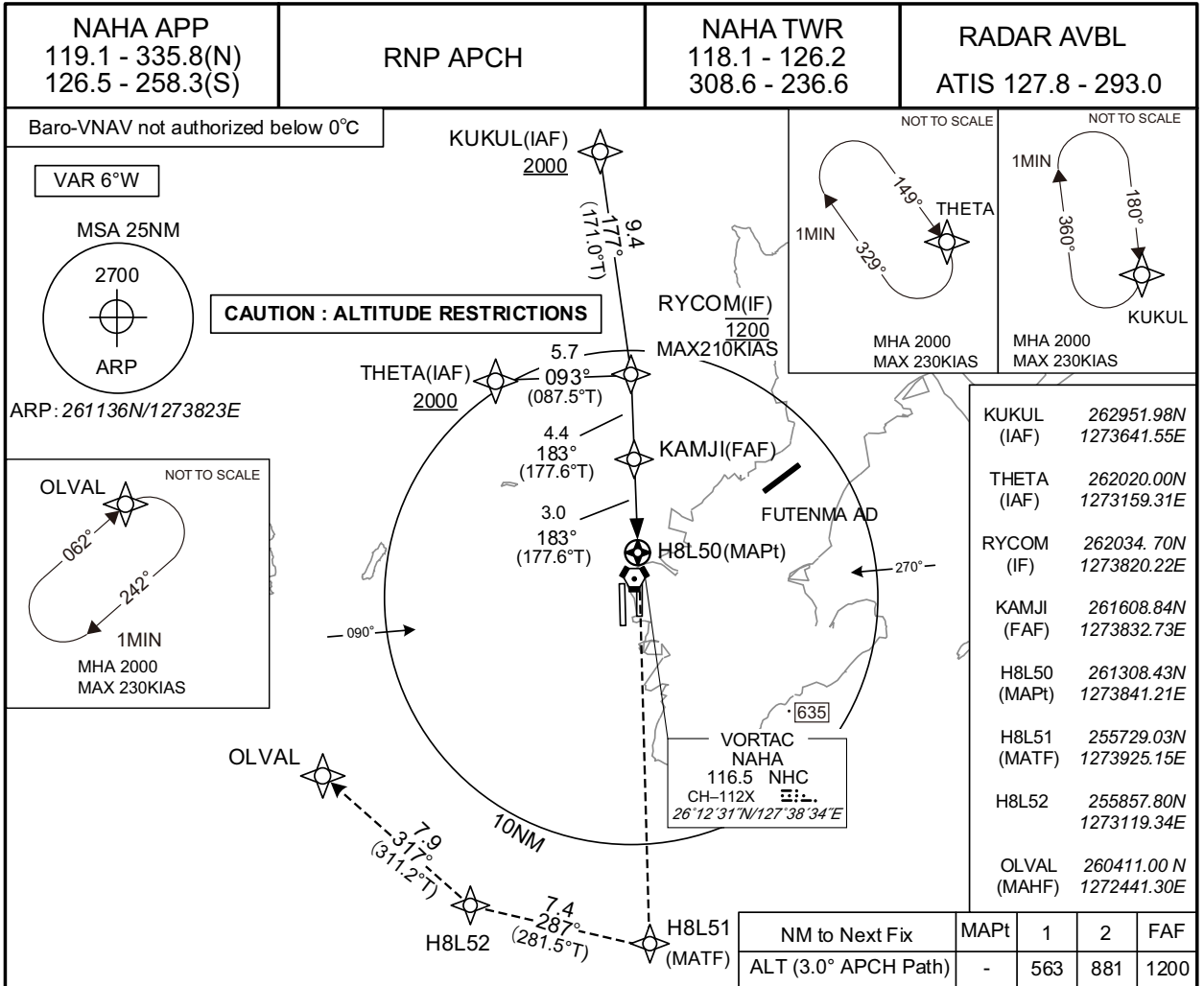

MINIMA		THR elev. 11		AD elev. 11			
CAT	RNAV/VNAV	RNAV		CIRCLING			
	DA(H)	RVR/CMV	MDA(H)	RVR/CMV	MDA(H) VIS		
A	430 (419)	1200	430 (419)	1200	620 (609)	1600	
B		1300		1300			
C		1400		1400			2400
D		1600		1600			3200

Circling to WEST side of RWY only.

INSTRUMENT APPROACH CHART

ROAH / NAHA

VOR A or TACAN B

<p><b>NAHA APP</b> 119.1 - 335.8(N) 126.5 - 258.3(S)</p>	<p><b>NAHA VORTAC</b> 116.5 NHC CH-112X 26°12'31"N/127°38'34"E</p>	<p><b>NAHA TWR</b> 118.75 - 118.1 247.8 - 308.6</p>	<p><b>RADAR AVBL</b> ATIS 127.8 - 293.0</p>
--	--	---	---

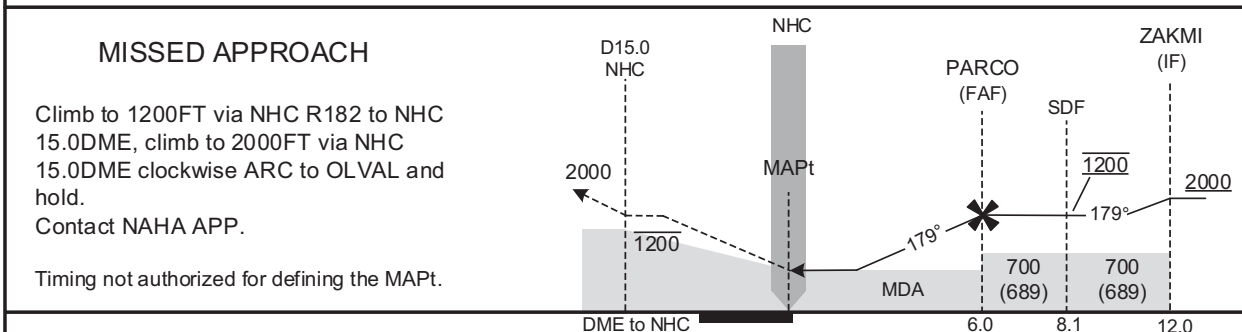
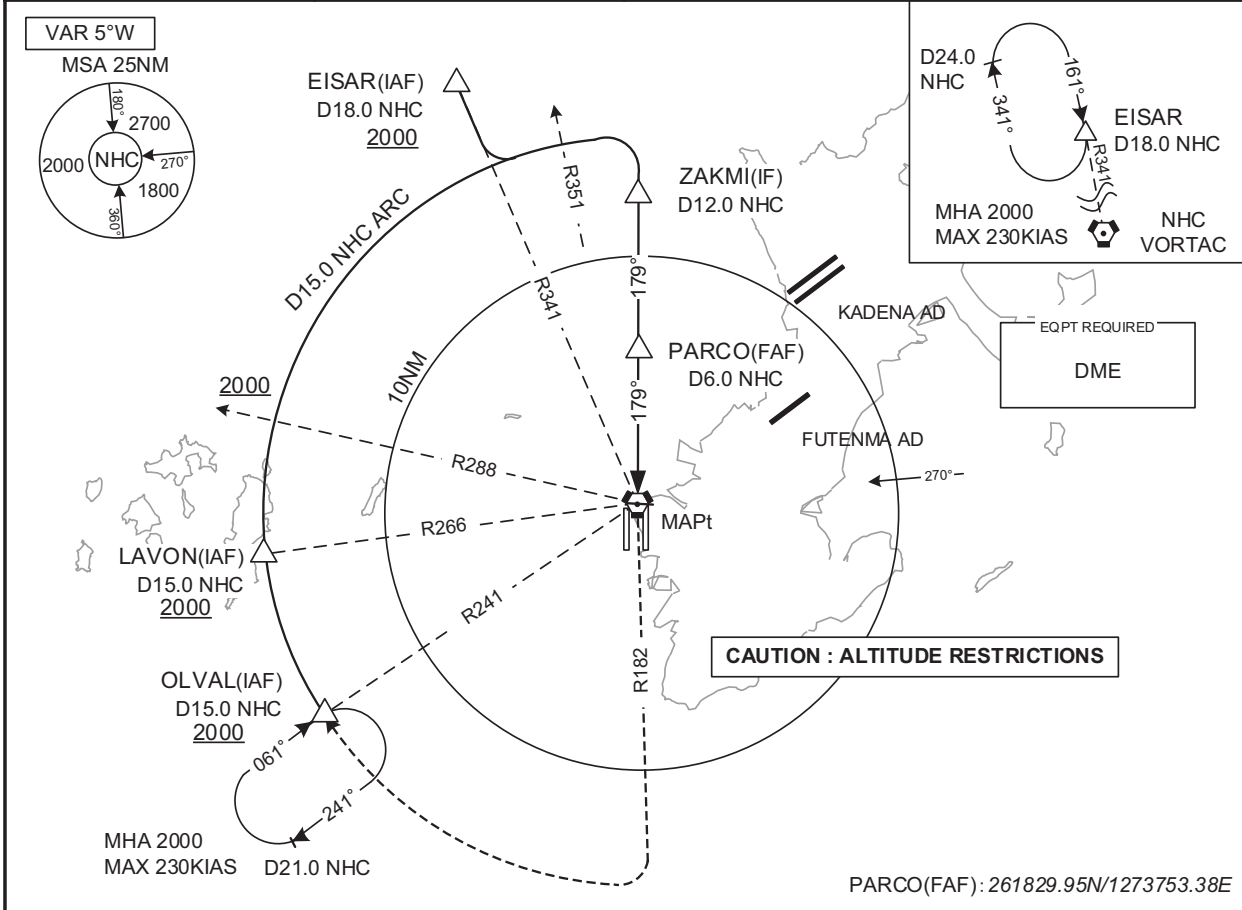

<b>MINIMA</b>		<b>AD elev. 11</b>	
<b>CAT</b>	<b>CIRCLING</b>		
	<b>MDA(H)</b>	<b>VIS</b>	
<b>A</b>	<b>620 (609)</b>	<b>1600</b>	
<b>B</b>		<b>2400</b>	
<b>C</b>		<b>3200</b>	
<b>D</b>			

CHANGE : Description of VAR.  
Circling to WEST side of RWY only.

INSTRUMENT APPROACH CHART

ROAH / NAHA

VOR C

<b>NAHA APP</b> 119.1 - 335.8(N) 126.5 - 258.3(S)	<b>NAHA VORTAC</b> 116.5 NHC CH-112X 26°12'31"N/127°38'34"E	<b>NAHA TWR</b> 118.75 - 118.1 247.8 - 308.6	<b>RADAR AVBL</b> ATIS 127.8 - 293.0
---	--	--	---

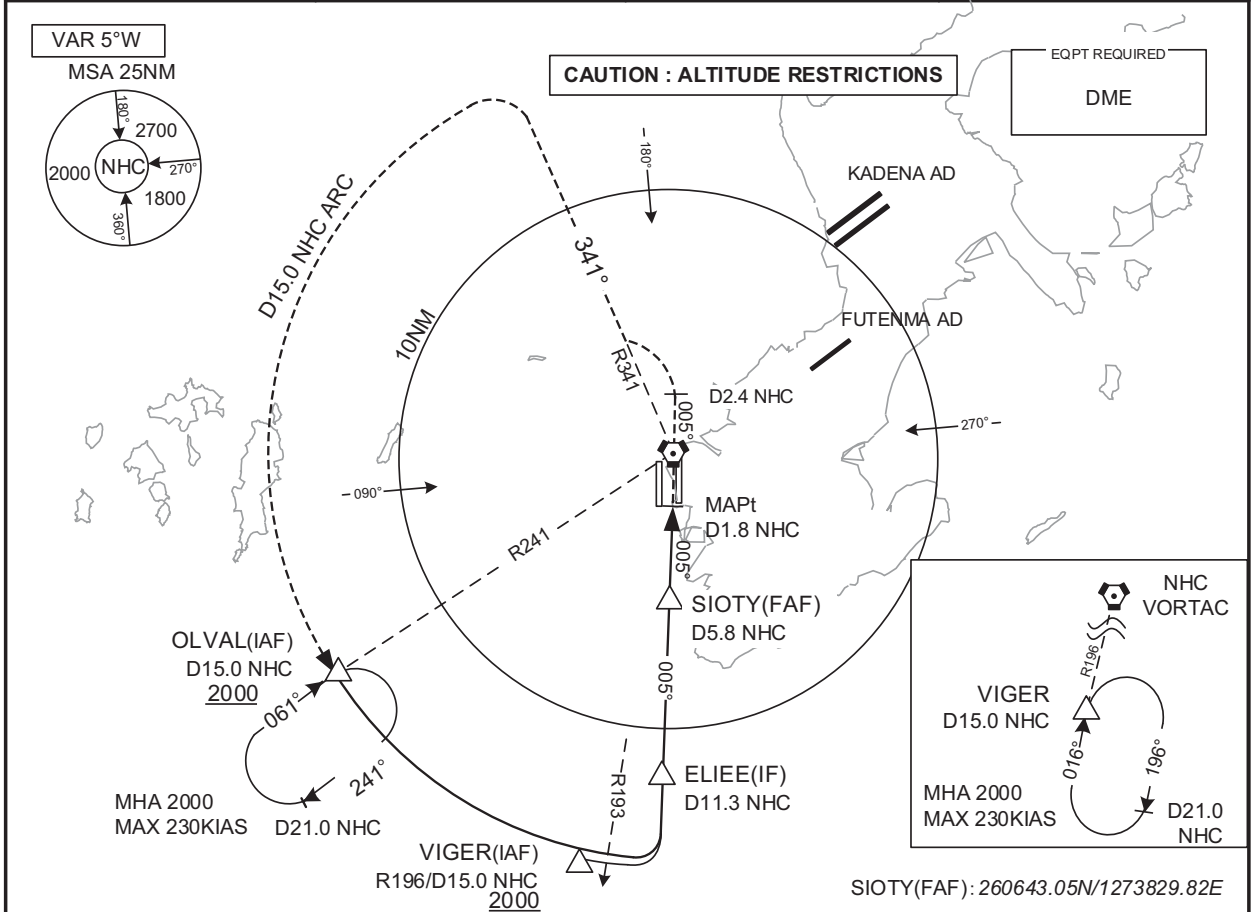

MISSED APPROACH

Climb to 1200FT via NHC R005 to NHC 2.4DME, turn left proceed via NHC R341 to NHC 15.0DME, climb to 2000FT via NHC 15.0 DME counterclockwise ARC to OLVAL and hold.

Contact NAHA APP.

Timing not authorized for defining the MAPt.

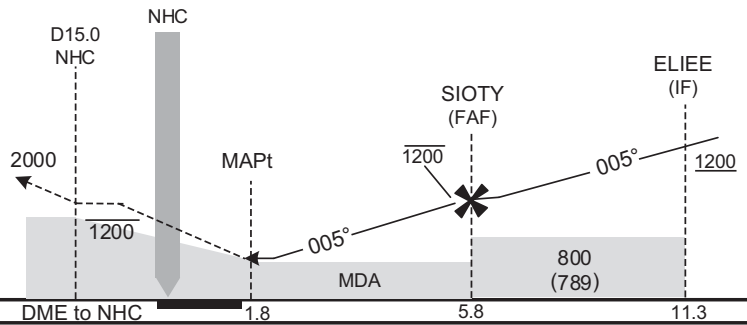

CHANGE : Description of VAR.

MINIMA		AD elev. 11	
CAT	CIRCLING		
	MDA(H)	VIS	
A	620 (609)	1600	
B		2400	
C		3200	
D			

Circling to WEST side of RWY only.

INSTRUMENT APPROACH CHART

ROAH / NAHA

TACAN D

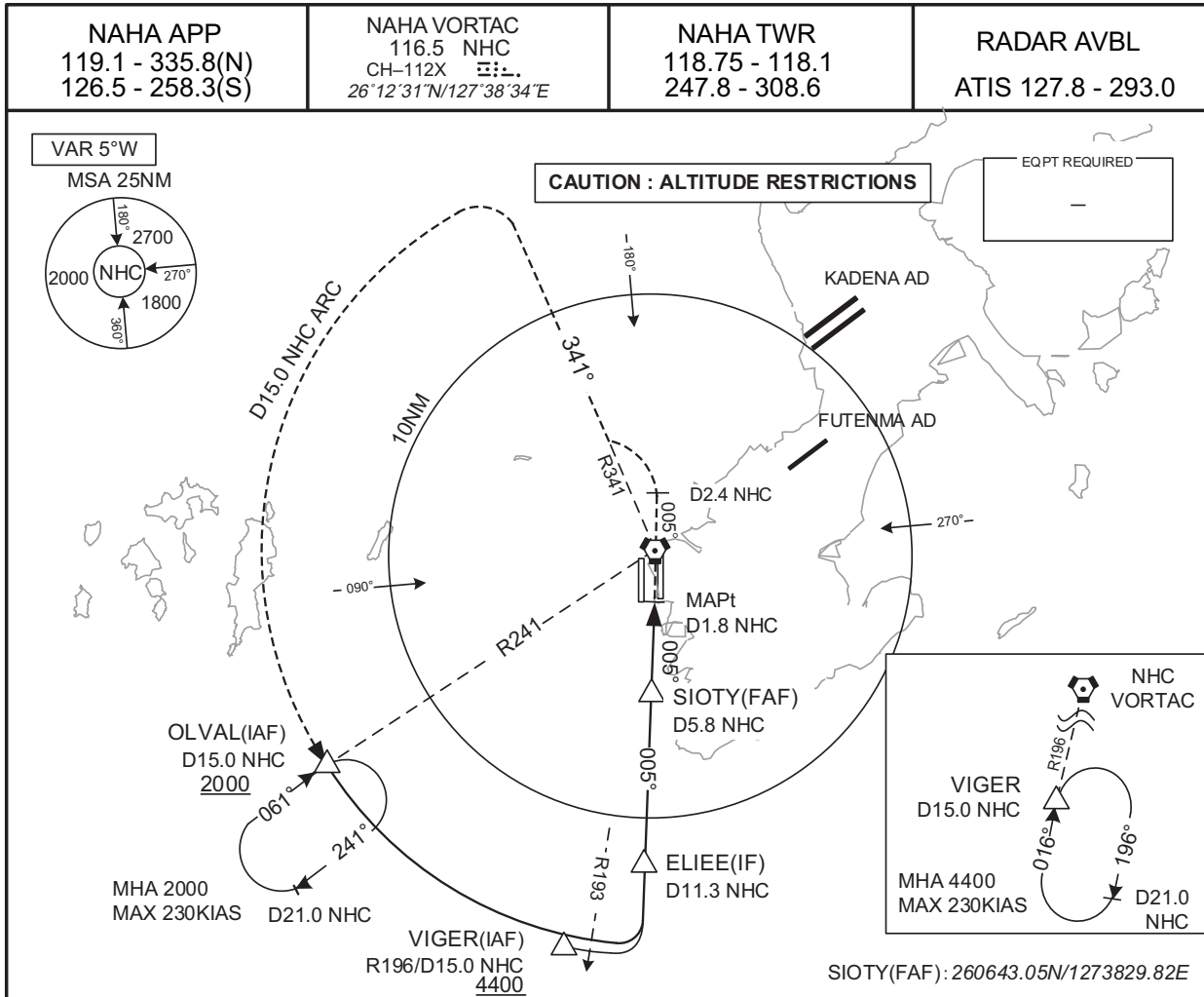

**MISSED APPROACH**

Climb to 1200FT via NHC R005 to NHC 2.4DME, turn left proceed via NHC R341 to NHC 15.0DME, climb to 2000FT via NHC 15.0 DME counterclockwise ARC to OLVAL and hold.  
Contact NAHA APP.

Timing not authorized for defining the MAPt.

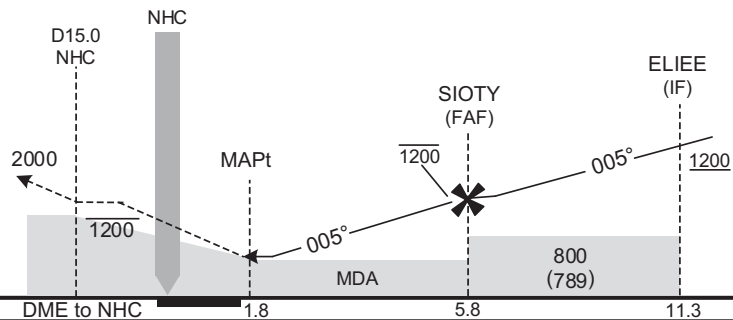

CHANGE : Description of VAR.

MINIMA		AD elev. 11
CAT	CIRCLING	
	MDA(H)	VIS
A	700 (689)	1600
B		2400
C		3200
D		

Circling to WEST side of RWY only.



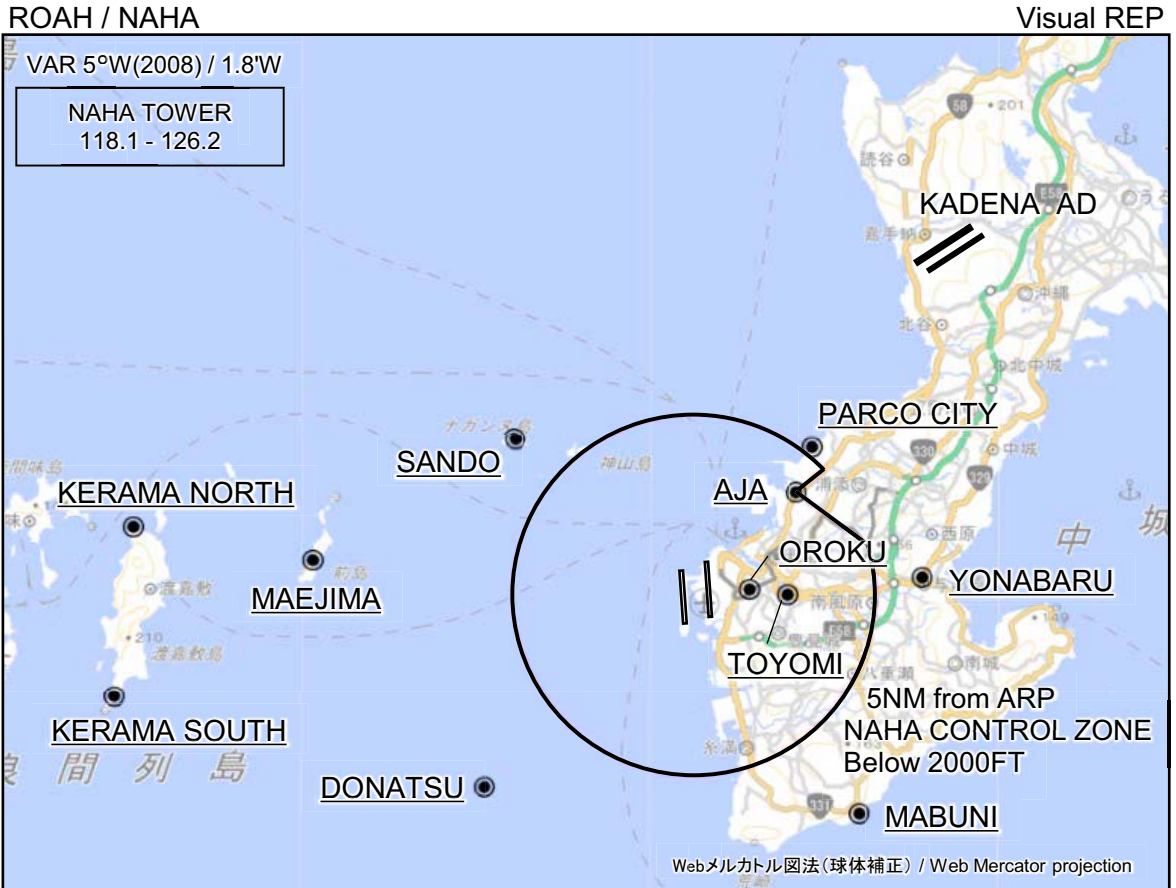

※図中に標高を示す数字がある場合、単位はメートル(m)である。The unit of measurement used to express elevation is meter(m).

CHANGE : Map updated. BRG/DIST from ARP. Visual REP established(Oroku, Parco City, Toyomi).

Call sign	BRG / DIST from ARP	Remarks
サンド Sando	311°T / 6.6NM	ナガンヌ島 Island
慶良間ノース Kerama North	277°T / 15.4NM	渡嘉敷島北端 North edge of island
前島 Maejima	276°T / 10.5NM	前島 Island
慶良間サウス Kerama South	260°T / 16.1NM	渡嘉敷島南端 South edge of island
ドーナツ Donatsu	227°T / 7.8NM	ルカン礁 Coral reef
パルコシティ Parco City	037°T / 5.2NM	パルコシティ Shopping mall
安謝 Aja	043°T / 4.0NM	国道58号線安謝橋 Bridge
小禄 Oroku	083°T / 1.5NM	モノレール小禄駅 Station
与那原 Yonabaru	085°T / 6.2NM	国道329号線与那原交叉点 Intersection
とよみ Toyomi	090°T / 2.5NM	とよみ大橋と爬龍橋の交点 Intersection
摩文仁 Mabuni	143°T / 7.5NM	平和祈念公園 Park





ROAH / NAHA

Minimum Vectoring Altitude CHART

VAR 5°W (2011)

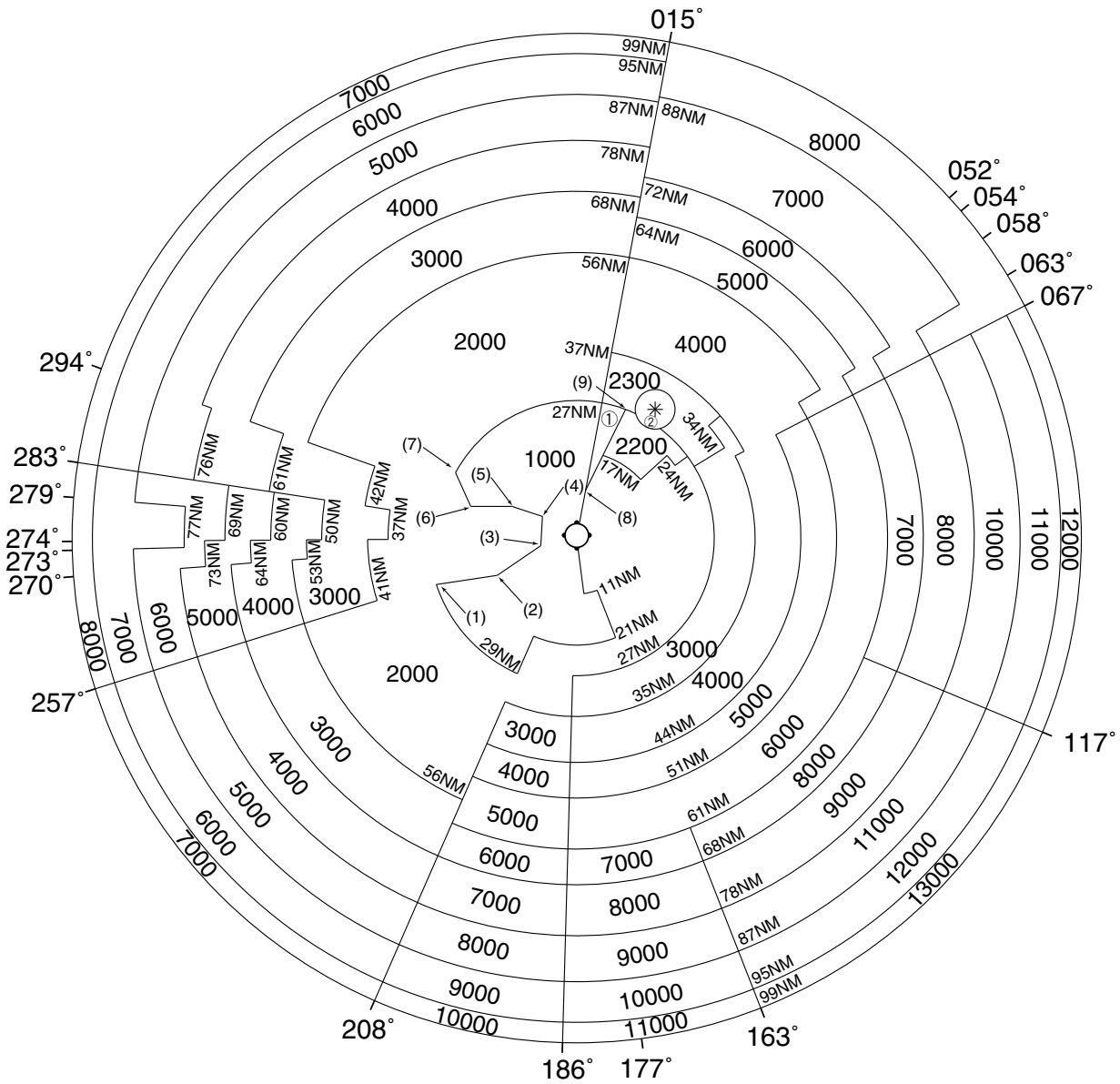

- |        |                      |                      |                                |
|--------|----------------------|----------------------|--------------------------------|
| ① 1500 | (1) 260301N/1270807E | (6) 261829N/1271524E | CENTER: 261231N/1273834E (NHC) |
| ② 2600 | (2) 260459N/1272121E | (7) 262505N/1271157E | * : 263759N/1275528E           |
|        | (3) 261057N/1273045E | (8) 262154N/1274025E | RADIUS 3.9NM                   |
|        | (4) 261640N/1273102E | (9) 263755N/1274900E |                                |
|        | (5) 261835N/1272422E |                      |                                |