

AD 2 AERODROMES

ROYN AD 2.1 AERODROME LOCATION INDICATOR AND NAME

ROYN - YONAGUNI

ROYN AD 2.2 AERODROME GEOGRAPHICAL AND ADMINISTRATIVE DATA

1	ARP coordinates and site at AD	242803N/1225847E 075°/1.00km from RWY 08 THR
2	Direction and distance from (city)	124km W from ISHIGAKI City
3	Elevation/ Reference temperature	49ft / 32.7°C(2001 - 2005)
4	Geoid undulation at AD ELEV PSN	76ft
5	MAG VAR/ Annual change	5°W(2022) / 7°W
6	AD Administration, address, telephone, telefax, telex, AFS, e-mail and/or Web-site addresses	OKINAWA PREF. Public AP. 4350, Aza-Yonaguni, Yonaguni-cho, Yaeyama-gun, Okinawa Pref Tel 0980-87-8375, 0980-87-3266 Fax 0980-87-2913, E-mail:aa063002@pref.okinawa.lg.jp Web: http://www.pref.okinawa.jp/
7	Types of traffic permitted (IFR/ VFR)	IFR/VFR
8	Remarks	Nil

ROYN AD 2.3 OPERATIONAL HOURS

1	AD Administration	2300 - 1030
2	Customs and immigration	On request Customs: 0980-87-2804 Immigration: 0980-82-2333
3	Health and sanitation	Quarantine (human): On request (0980-82-4940) Quarantine (animal, plant): Nil
4	AIS Briefing Office	Nil
5	ATS Reporting Office(ARO)	Nil
6	MET Briefing Office	H24 (NAHA)
7	ATS	2300 - 1030 Remarks: AFIS provided by Naha Airport Office.
8	Fuelling	Nil
9	Handling	2300 - 1030
10	Security	2300 - 1030
11	De-icing	Nil
12	Remarks	Nil

ROYN AD 2.4 HANDLING SERVICES AND FACILITIES

1	Cargo-handling facilities	Ask AD Administration
2	Fuel/ oil types	Nil
3	Fuelling facilities/ capacity	Nil
4	De-icing facilities	Nil
5	Hangar space for visiting aircraft	Nil
6	Repair facilities for visiting aircraft	Nil
7	Remarks	Nil

ROYN AD 2.5 PASSENGER FACILITIES

1	Hotels	Hotels in Yonaguni-cho
2	Restaurants	Restaurants in Yonaguni-cho
3	Transportation	Busses and Taxis
4	Medical facilities	Clinic in Yonaguni-cho 4.0km
5	Bank and Post Office	Post Office in Yonaguni-cho
6	Tourist Office	Nil
7	Remarks	Nil

ROYN AD 2.6 RESCUE AND FIRE FIGHTING SERVICES

1	AD category for fire fighting	CAT 6
2	Rescue equipment	Chemical fire fighting truck x 2
3	Capability for removal of disabled aircraft	Incapable
4	Remarks	Nil

ROYN AD 2.7 SEASONAL AVAILABILITY-CLEARING

1	Types of clearing equipment	Not Applicable
2	Clearance priorities	Not Applicable
3	Remarks	Nil

ROYN AD 2.8 APRONS, TAXIWAYS AND CHECK LOCATIONS DATA

1	Apron surface and strength	Surface: Asphalt-concrete Strength: PCN 40/F/A/X/T
2	Taxiway width, surface and strength	Width: 23m Surface: Asphalt-concrete Strength: PCN 52/F/A/X/T
3	ACL and elevation	Not Available
4	VOR checkpoints	Not Available
5	INS checkpoints	Spot NR S-1 : 242756.96N/1225845.44E S-2 : 242757.51N/1225847.70E
6	Remarks	Nil

ROYN AD 2.9 SURFACE MOVEMENT GUIDANCE AND CONTROL SYSTEM AND MARKINGS

1	Use of aircraft stand ID signs, TWY guide lines and Visual docking/ parking guidance system of aircraft stands	Nil
2	RWY and TWY markings and LGT	RWY: RWY08/26 (Marking): RWY designation, RWY CL, RWY THR, RWY middle point, TDZ, RWY side stripes, Aiming point (LGT): RCLL, REDL, RENL, RTHL TWY: (Marking): TWY CL, RWY HLDG PSN, TWY side stripe (LGT): TWY edge LGT, TWY CL LGT
3	Stop bars	Nil
4	Remarks	(Marking): Overrun area, Apron TWY CL (LGT): Apron flood LGT

ROYN AD 2.10 AERODROME OBSTACLES

In Area2 See Obstacle data

In Area3 To be developed

ROYN AD 2.11 METEOROLOGICAL INFORMATION PROVIDED

1	Associated MET Office	NAHA
2	Hours of service MET Office outside hours	H24 (NAHA)
3	Office responsible for TAF preparation Periods of validity	Nil
4	Trend forecast Interval of issuance	Nil
5	Briefing/ consultation provided	Briefing is available upon inquiry at NAHA
6	Flight documentation Language(s) used	C En
7	Charts and other information available for briefing or consultation	S ₆ , U ₈₅ , U ₇ , U ₅ , U ₃ , U ₂₅ , U ₂ /T _r , P _S , P ₅ , P ₃ , P ₂₅ , P _{SWE} , P _{SWF} , P _{SWG} , P _{SWI} , P _{SWM} , P _{SW} (domestic), E, C, W _E , W _F , W _G , W _I , W, N
8	Supplementary equipment available for providing information	Nil
9	ATS units provided with information	RADIO
10	Additional information(limitation of service, etc.)	Nil

ROYN AD 2.12 RUNWAY PHYSICAL CHARACTERISTICS

Designations RWY NR	TRUE BRG	Dimensions of RWY(M)	Strength(PCN) and surface of RWY	THR coordinates THR geoid undulation	THR elevation and highest elevation of TDZ of precision APP RWY
1	2	3	4	5	6
08	075.27°	2000x45	PCN 52/F/A/X/T Asphalt-concrete	242754.37N 1225812.86E 76ft	THR ELEV: 71.9FT
26	255.27°	2000x45	PCN 52/F/A/X/T Asphalt-concrete	242810.89N 1225921.54E 76ft	THR ELEV: 41.6FT

Slope of RWY	Strip Dimensions(M)	RESA(Overrun) Dimensions(M)	Remarks
7	10	11	14
See below figure	2120x150 2120x150	91x156 200x156	RWY Grooving : 30m x 2000m

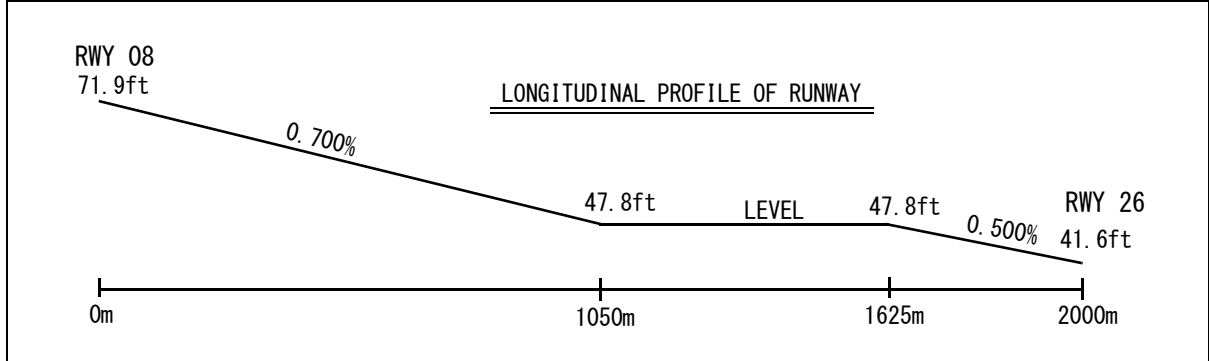

ROYN AD 2.13 DECLARED DISTANCES

RWY Designator	TORA (m)	TODA (m)	ASDA (m)	LDA (m)	Remarks
1	2	3	4	5	6
08	2000	2000	2000	2000	Nil
26	2000	2000	2000	2000	Nil

ROYN AD 2.14 APPROACH AND RUNWAY LIGHTING

RWY Designator	APCH LGT type LEN INTST	RTHL Color WBAR	PAPI (VASIS) Angle DIST FM THR MEHT	RTZL LEN	RCLL LEN Spacing Color INTST	REDL LEN Spacing Color INTST	RENL Color WBAR	STWL LEN Color
1	2	3	4	5	6	7	8	9
08	-	Green	PAPI 3.0° /LEFT 356.1m 49ft	-	2,000m 30m Coded color LIH	2,000m 60m Coded color LIH	Red	Nil(*2)
26	SALS (*1) 420m LIH	Green -	PAPI 3.0°/LEFT 276.6m 49ft	-	2,000m 30m Coded color LIH	2,000m 60m Coded color LIH	Red	Nil(*2)
Remarks								
10								
SALS with RAI(LEN:360m)(*1) Overrun area edge LGT(LEN:60m Color:Red)(*2) RWY THR ID LGT for RWY 08 THR (Color: White)								

ROYN AD 2.15 OTHER LIGHTING, SECONDARY POWER SUPPLY

1	ABN/IBN location, characteristics and hours of operation	ABN: 242756N/1225853E, White/Green EV4.3sec, HO
2	LDI location and LGT Anemometer location and LGT	LDI : Nil Anemometer : AVBL
3	TWY edge and centerline lighting	TWY edge and center line lights installed, see AD2.9
4	Secondary power supply/ switch-over time	Within 15sec: All Lights
5	Remarks	Nil

ROYN AD 2.16 HELICOPTER LANDING AREA

Nil

ROYN AD 2.17 ATS AIRSPACE

Designation and lateral limits		Vertical limits (ft)	Airspace classification	ATS unit call sign Language	Remarks
1		2	3	4	6
Yonaguni Information Zone	Area within a radius of 5nm of Yonaguni ARP	----- 3000	-	Yonaguni Radio En	Nil

ROYN AD 2.18 ATS COMMUNICATION FACILITIES

Service designation	Call sign	Frequency	Hours of operation	Remarks
1	2	3	4	5
AFIS	Yonaguni Radio	118.5MHz	2300 - 1030	Operated by Naha Airport Office.

ROYN AD 2.19 RADIO NAVIGATION AND LANDING AIDS

Type of aid (VOR declination)	ID	Frequency	Hours of operation	Position of transmitting antenna coordinates	Elevation of DME transmitting antenna	Remarks
1	2	3	4	5	6	7
VOR (5°W/2019)	YNE	115.05MHz	H24	242753.72N/1225951.86E		Unusable: 140° -170° beyond 20nm
DME	YNE	1058MHz (CH-97Y)	H24	242753.72N/1225951.86E	314.6ft	BLW 4000ft.
LOC 26	IYN	108.55MHz	2300-1030	242752.42N/1225804.79E		LOC 26: 235m (771ft) away FM RWY 08 THR, BRG (MAG) 260.21°
LOC-DME 26	IYN	1109MHz (CH-22Y)	2300-1030	242750.22N/1225805.42E		DME 26: 235m (771ft) inside FM RWY 08 THR, 70m (230ft) S of RCL. ELEV 25.9m (85ft). Unusable: beyond 30° south (90Hz) side of course
MSAS		1575.42MHz	H24			Transmitting antennas are satellite based.

LOC and LOC-DME for RWY26

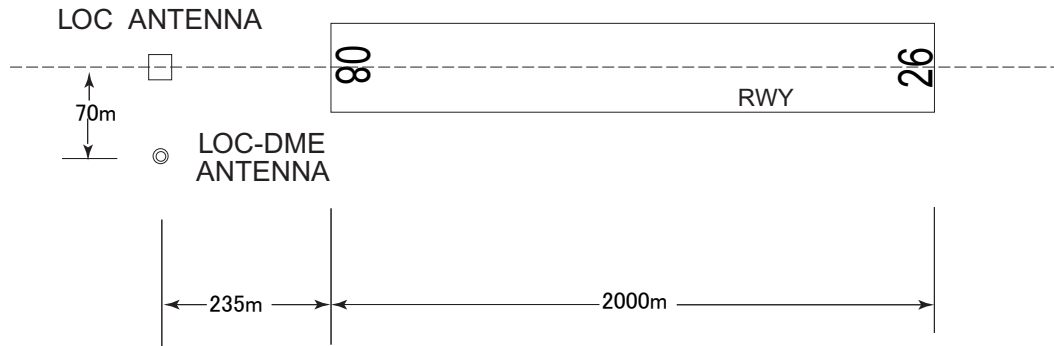

REMARKS : 1. LOC beam BRG(MAG) 260.21°
2. ELEV of LOC-DME 25.9m(85ft)

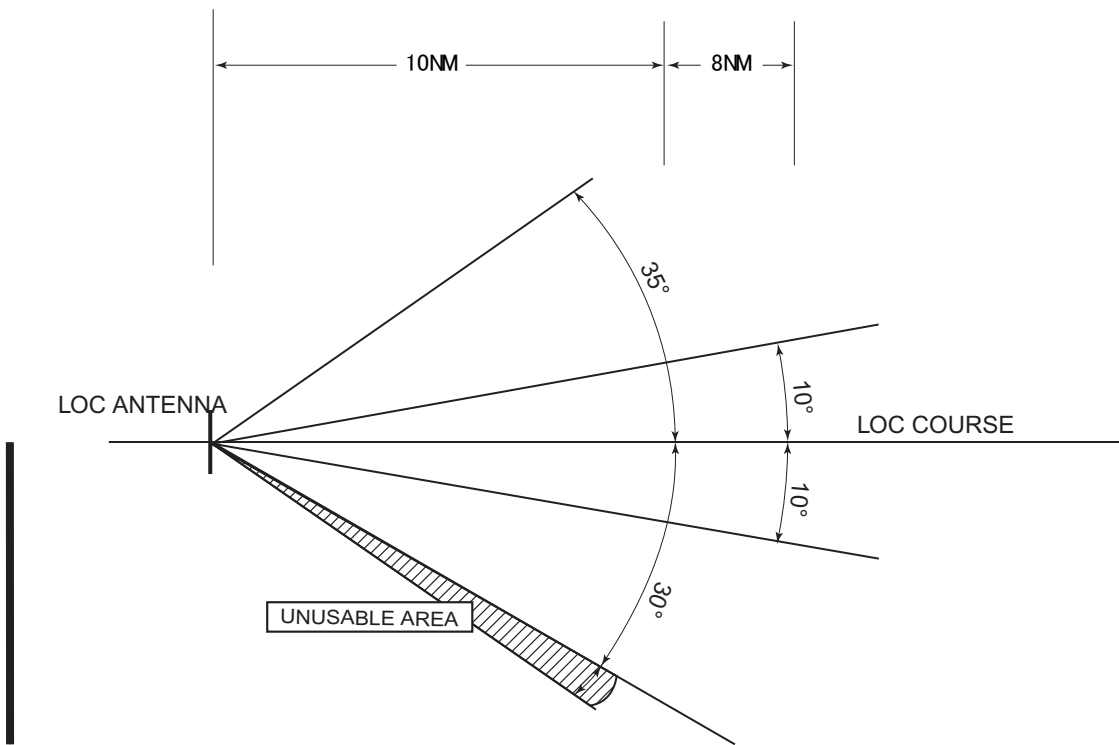

UNUSABLE :BEYOND 30DEG SOUTH (90Hz) SIDE OF COURSE.

ROYN AD 2.20 LOCAL TRAFFIC REGULATIONS

1. Airport regulations

On use of YONAGUNI airport, aircraft operator is required to notify Okinawa Pref. in advance.

2. Taxiing to and from stands

Nil

3. Parking area for small aircraft(General aviation)

Nil

4. Parking area for helicopters

Nil

5. Apron - taxiing during winter conditions

Nil

6. Taxiing - limitations

Nil

7. School and training flights - technical test flights - use of runways

Nil

8. Helicopter traffic - limitation

Nil

9. Removal of disabled aircraft from runways

Nil

ROYN AD 2.21 NOISE ABATEMENT PROCEDURES

Ask AD administration

ROYN AD 2.22 FLIGHT PROCEDURES

TAKE OFF MINIMA

	RWY	ACFT CAT	REDL & RCLL	REDL or RCLL or RCL Marking	NIL (DAYTIME ONLY)
			CEIL-VIS	CEIL-VIS	CEIL-VIS
Multi-Engine ACFT-with TKOF ALTN AP Filed	08	A,B,C,D	0-400m	0-400m	0-500m
	26		900-2400m* 300-2400m** 0-400m***	900-2400m* 300-2400m** 0-400m***	900-2400m* 300-2400m** 0-500m***
OTHER	08	A,B,C,D	AVBL LDG MINIMA		
	26				

* Applicable to Conventional Departure in case of not climbing with 9.0%.

**Applicable to RNAV Departure in case of not climbing with 7.2%.

***Applicable to Conventional Departure in case of climbing with 9.0% gradient up to 900FT.

***Applicable to RNAV Departure in case of climbing with 7.2% gradient up to 600FT.

ROYN AD 2.23 ADDITIONAL INFORMATION

Ask AD administration

ROYN AD 2.24 CHARTS RELATED TO AN AERODROME

Aerodrome/Heliport Chart
 Standard Departure Chart - Instrument (TAKZO, ABASA)
 Standard Departure Chart - Instrument (AYAKA-RNAV)
 Standard Arrival Chart - Instrument (ABASA-RNAV)
 Instrument Approach Chart (LOC RWY26)
 Instrument Approach Chart (VOR RWY26)
 Instrument Approach Chart (RNP RWY26)
 Other Chart (Visual REP)
 Other Chart (MVA CHART)

ROYN / YONAGUNI

AD CHART

CHANGE : VAR.

YONAGUNI AIRPORT

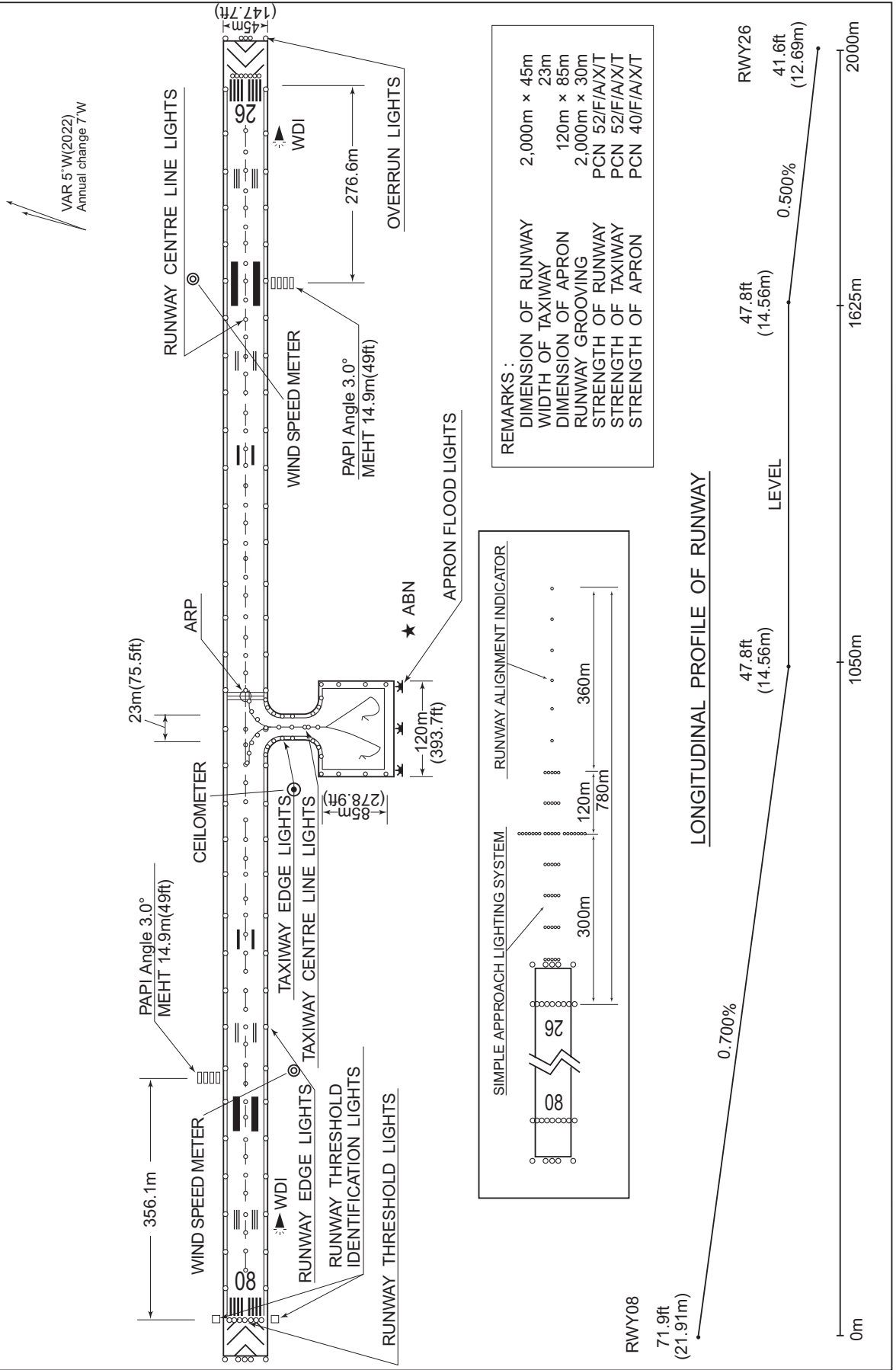

STANDARD DEPARTURE CHART -INSTRUMENT

ROYN / YONAGUNI

SID

TAKZO TWO DEPARTURE

RWY 08 : Climb RWY HDG until 3NM from RWY end/YNE 2.7DME, turn left,...

RWY 26 : Climb RWY HDG until 700FT, turn right, ...climb via YNE R022 to TAKZO.

Note RWY08 : 6.7% climb gradient required up to 700FT.

OBST ALT 89FT located at 0.1NM 126° FM end of RWY08.

RWY26 : No turn before DER.

In case of climbing with 9.0 % gradient up to 900FT, another TKOF WX MINIMA is applicable.

OBST ALT 358FT located at 0.6NM 236° FM end of RWY26,

OBST ALT 912FT located at 2.1NM 115° FM end of RWY26.

ABASA TWO DEPARTURE

RWY 08 : Climb RWY HDG until 3NM from RWY end/YNE 2.7DME, turn right,...

RWY 26 : Climb RWY HDG until 700FT, turn right, ...climb via YNE R101 to ABASA.

Note RWY08 : 6.7% climb gradient required up to 700FT.

OBST ALT 89FT located at 0.1NM 126° FM end of RWY08.

RWY26 : No turn before DER.

In case of climbing with 9.0 % gradient up to 900FT, another TKOF WX MINIMA is applicable.

OBST ALT 358FT located at 0.6NM 236° FM end of RWY26,

OBST ALT 912FT located at 2.1NM 115° FM end of RWY26.

CHANGE : PROC renamed. Radial FM YNE. Note RWY08 added. OBST chart added.

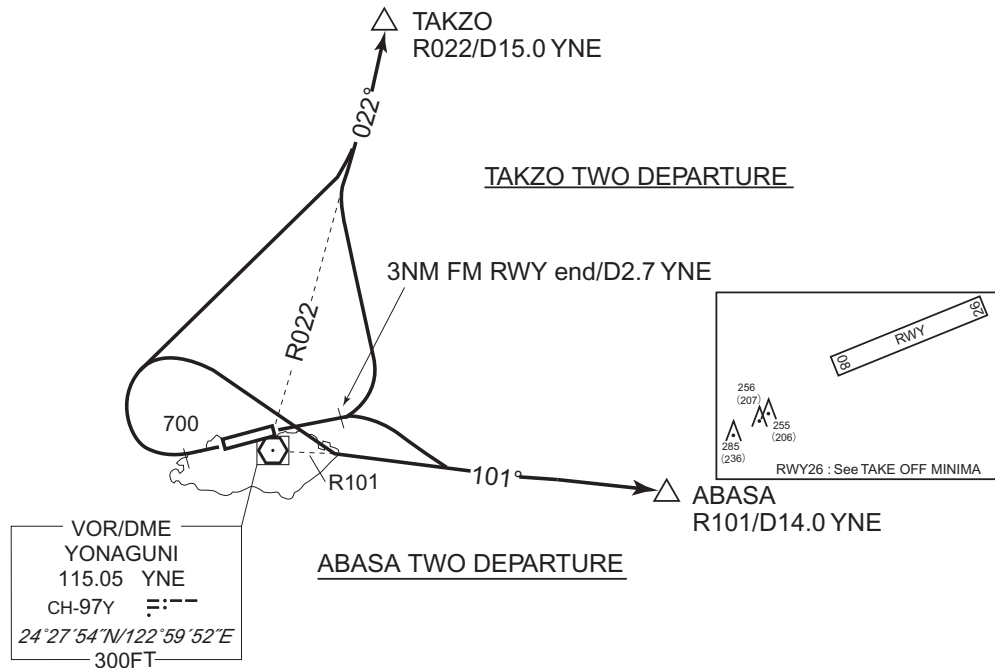

STANDARD DEPARTURE CHART -INSTRUMENT

ROYN / YONAGUNI

RNAV SID

AYAKA ONE DEPARTURE	RNP1
---------------------	------

Note GNSS required.

VAR 5°W

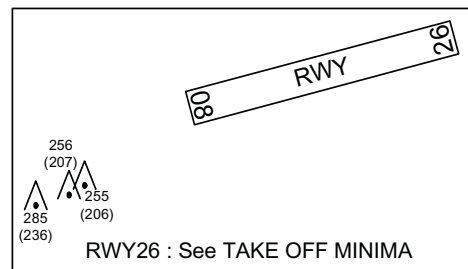
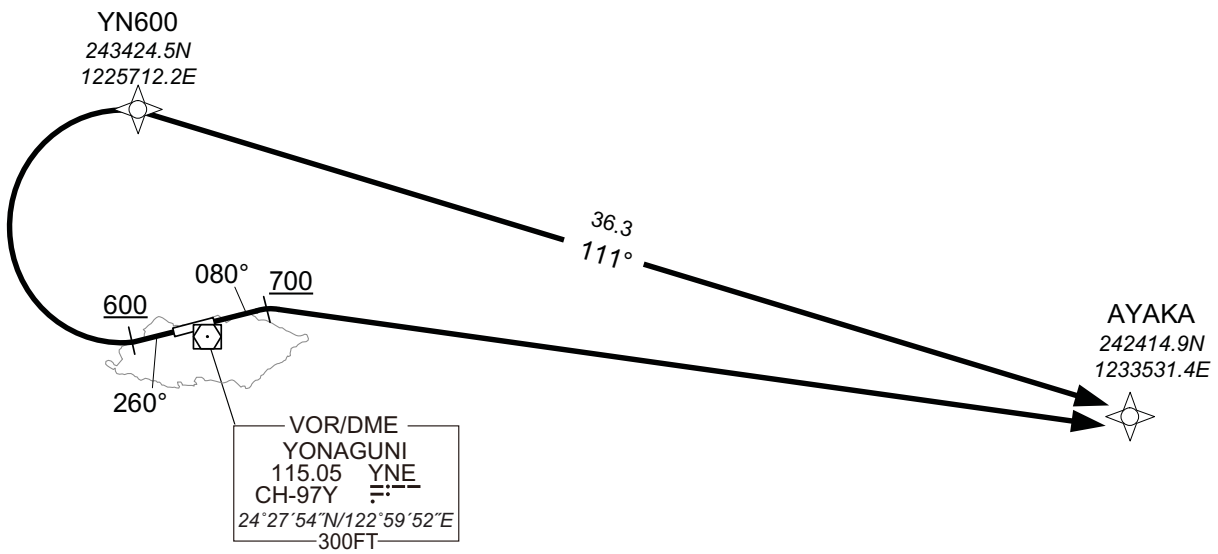

CHANGE : Navigation Specification(Basic RNP1 → RNP1).

RWY08 : Climb on HDG080° at or above 700FT, turn right direct to AYAKA.
 RWY26 : Climb on HDG260° at or above 600FT, turn right direct to YN600,to AYAKA.

Note RWY08 : 6.7% climb gradient required up to 700FT.
 OBST ALT 89FT located at 0.1NM 126° FM end of RWY08.

RWY26 : In case of climbing with 7.2% gradient up to 600FT, another TKOF WX
 MINIMA is applicable.
 OBST ALT 271FT located at 0.5NM 237° FM end of RWY26.

STANDARD DEPARTURE CHART -INSTRUMENT

ROYN / YONAGUNI

RNAV SID

AYAKA ONE DEPARTURE

RWY08

Serial Number	Path Descriptor	Waypoint Identifier	Fly Over	Course °M(°T)	Magnetic Variation	Distance (NM)	Turn Direction	Altitude (FT)	Speed (KIAS)	Vertical Angle	Navigation Specification
001	VA	-	-	080 (075.2)	-4.6	-	-	+700	-	-	RNP1
002	DF	AYAKA	-	-	-4.6	-	R	-	-	-	RNP1

RWY26

Serial Number	Path Descriptor	Waypoint Identifier	Fly Over	Course °M(°T)	Magnetic Variation	Distance (NM)	Turn Direction	Altitude (FT)	Speed (KIAS)	Vertical Angle	Navigation Specification
001	VA	-	-	260 (255.2)	-4.6	-	-	+600	-	-	RNP1
002	DF	YN600	-	-	-4.6	-	R	-	-	-	RNP1
003	TF	AYAKA	-	111 (106.1)	-4.6	36.3	-	-	-	-	RNP1

CHANGE : Navigation Specification(Basic RNP1 → RNP1).

STANDARD ARRIVAL CHART-INSTRUMENT

ROYN / YONAGUNI

RNAV STAR RWY26

ABASA ARRIVAL	RNP1
---------------	------

Note GNSS required.

VAR 5°W

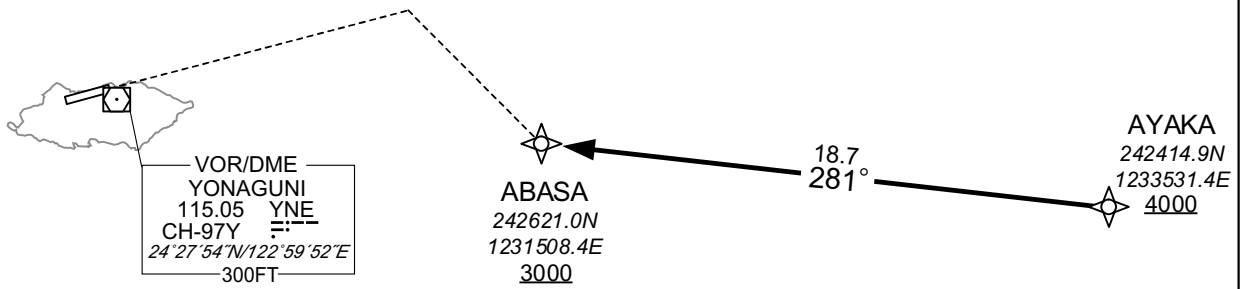

CHANGE : Navigation Specification(Basic RNP1 → RNP1).

From AYAKA at or above 4000FT, to ABASA at or above 3000FT.

Serial Number	Path Descriptor	Waypoint Identifier	Fly Over	Course °M(°T)	Magnetic Variation	Distance (NM)	Turn Direction	Altitude (FT)	Speed (KIAS)	Vertical Angle	Navigation Specification
001	IF	AYAKA	—	—	-4.6	—	—	+4000	—	—	RNP1
002	TF	ABASA	—	281 (276.5)	-4.6	18.7	—	+3000	—	—	RNP1

INTENTIONALLY LEFT BLANK

INSTRUMENT APPROACH CHART

ROYN / YONAGUNI LOC RWY26

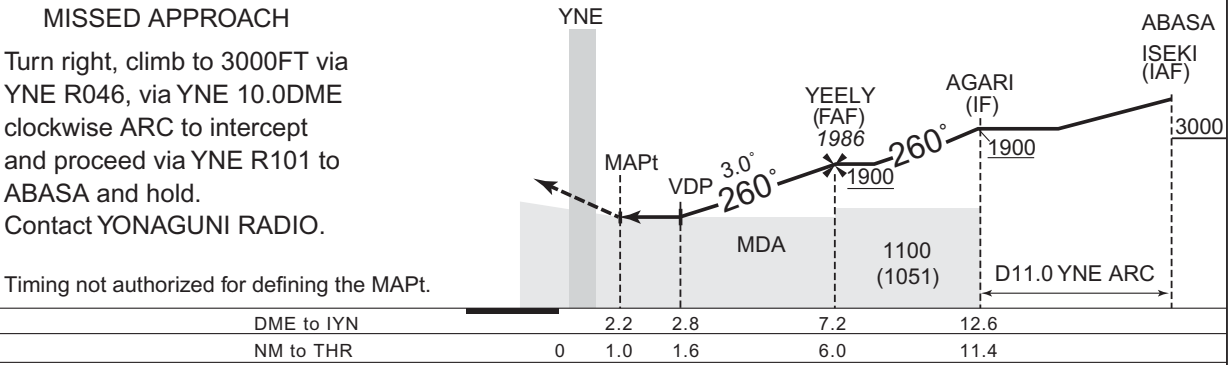
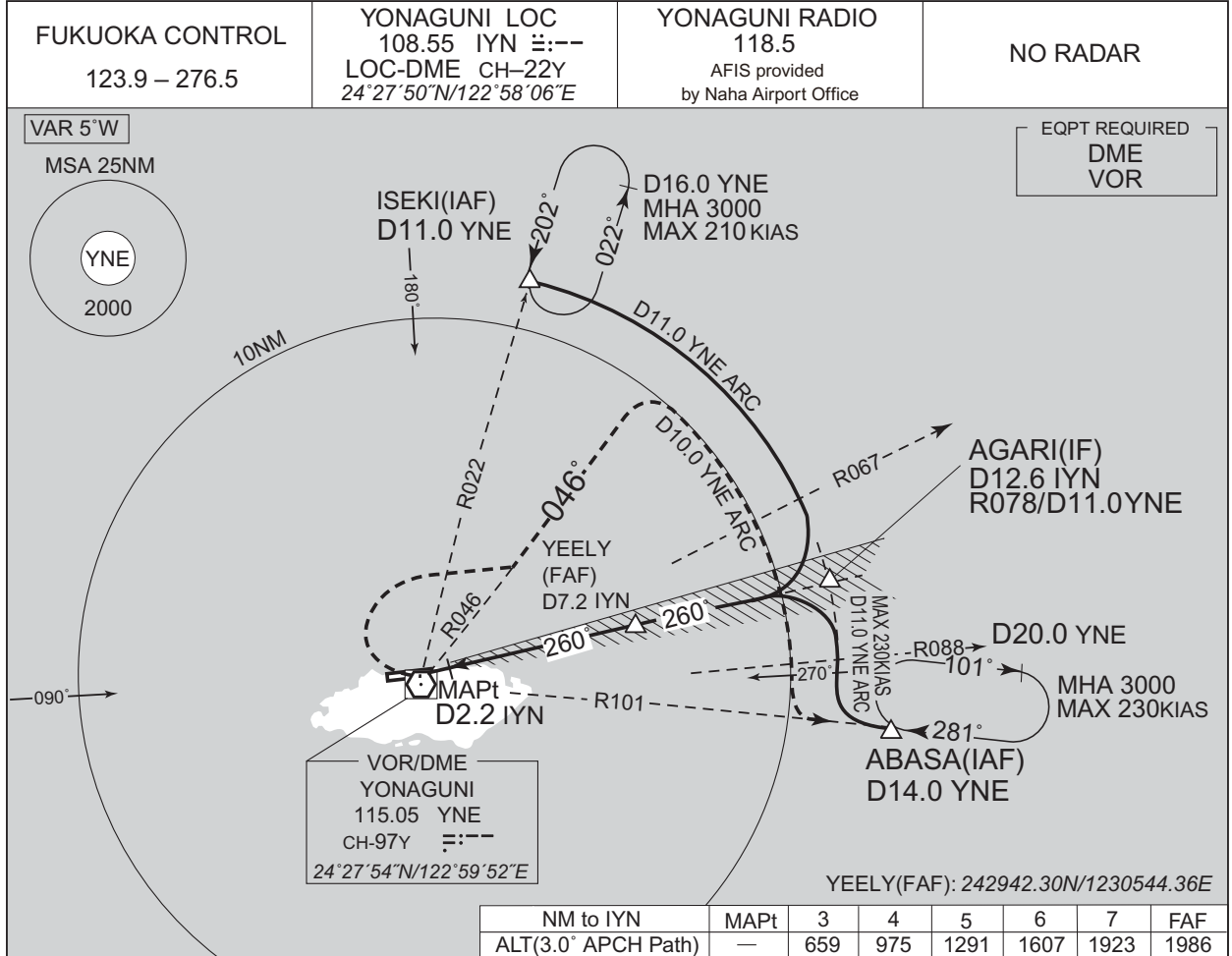

CHANGE : PROC course.

Missed APCH climb gradient MNM 5.0%

	MINIMA	THR elev. 42	AD elev. 49	
CAT	CIRCLING			
	MDA(H)	CMV	MDA(H)	VIS
A	570 (521)	1000	1020 (971)	1600
B		1200		2400
C		1600		3200
D				

MINIMA with Missed APCH climb gradient of 2.5% are not established.
Circling to NORTH side of RWY only.

INSTRUMENT APPROACH CHART

ROYN / YONAGUNI

VOR RWY26

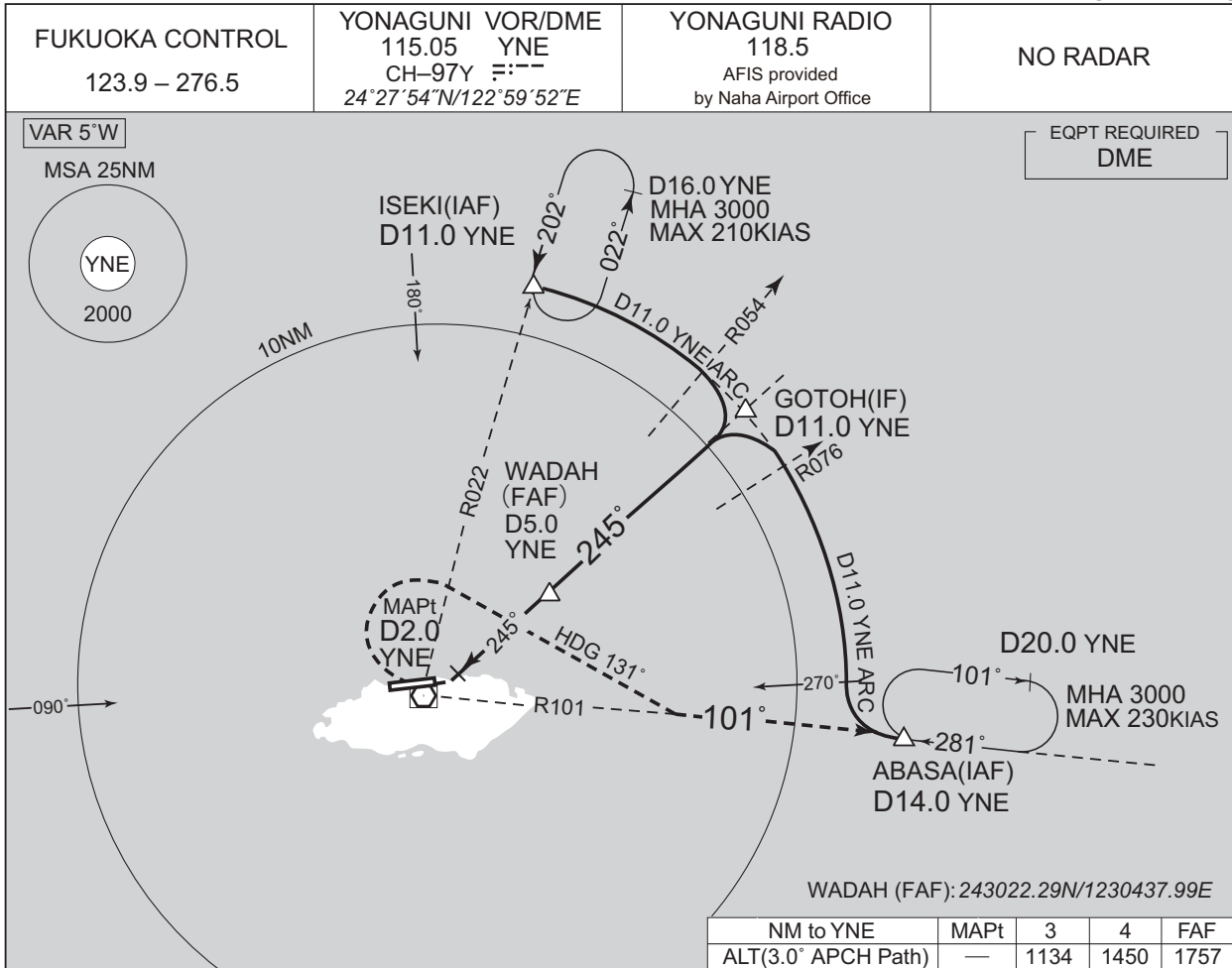

MISSED APPROACH

Turn right, climb to 3000FT via HDG 131° to intercept and proceed via YNE R101 to ABASA and hold.
Contact YONAGUNI RADIO.

Timing not authorized for defining the MAPt.

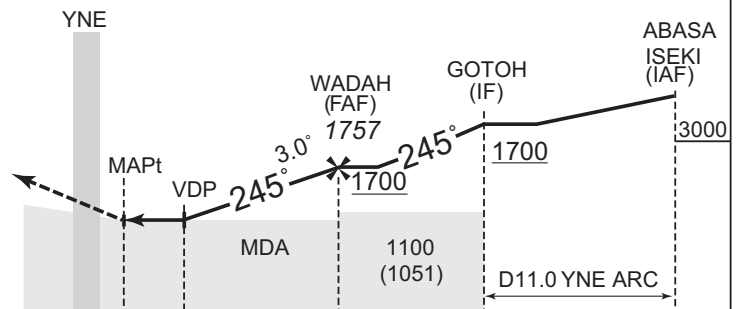

DME to YNE	0	2.0	2.3	5.0	11.0
NM to THR	0	2.3	2.6	5.3	11.3

Missed APCH climb gradient MNM 5.0%

MINIMA THR elev. 42 AD elev. 49

CAT	CIRCLING			
	MDA(H)	CMV	MDA(H)	VIS
A	880 (831)	1200	1020 (971)	1600
B		1400		2400
C		1800		3200
D				

MINIMA with Missed APCH climb gradient of 2.5% are not established.
Circling to NORTH side of RWY only.

CHANGE : Description of VAR.

INSTRUMENT APPROACH CHART

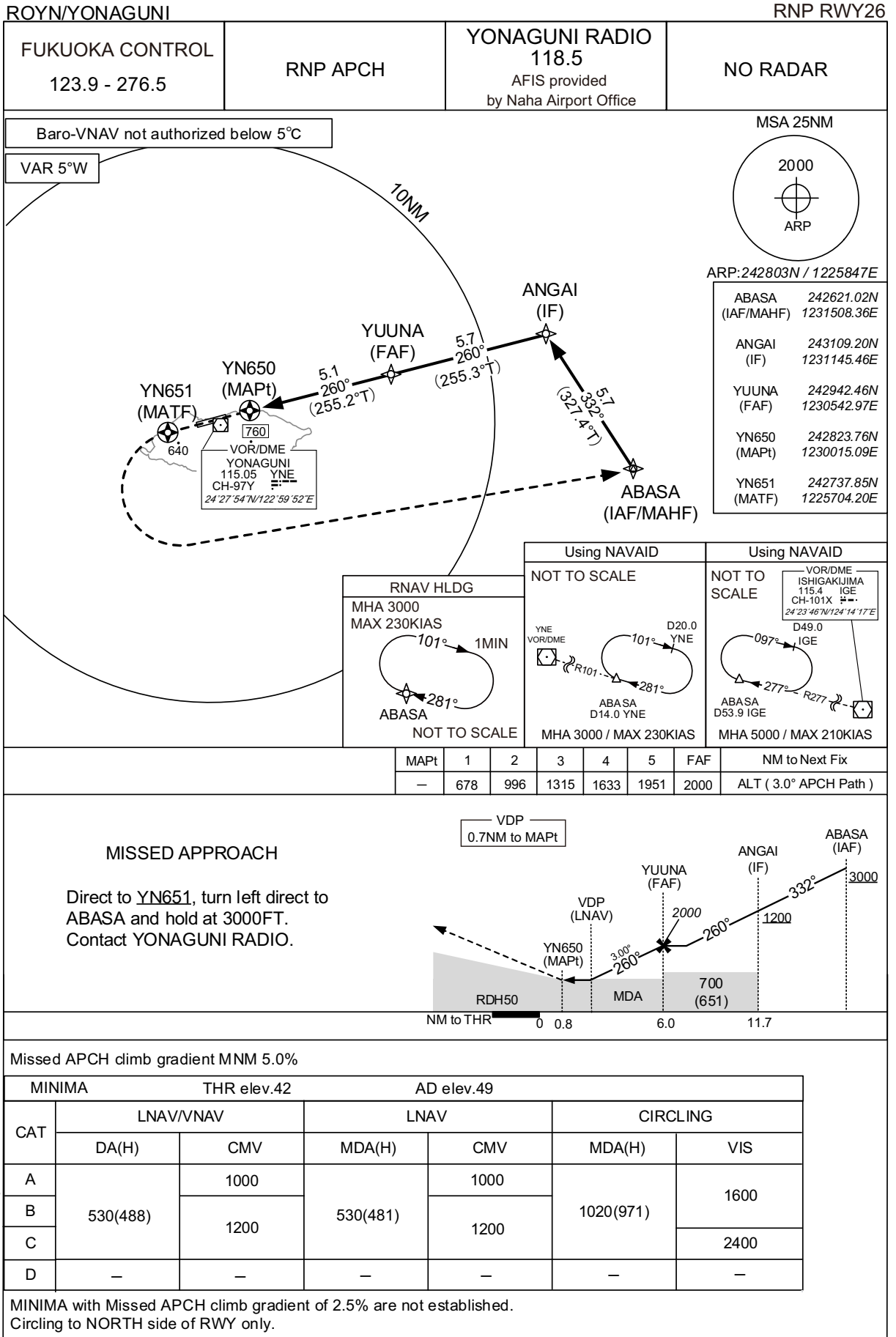

CHANGE : Description of VAR.

INTENTIONALLY LEFT BLANK

ROYN / YONAGUNI

Visual REP

VAR 5°W(2022) / 7°W

YONAGUNI RADIO
118.5

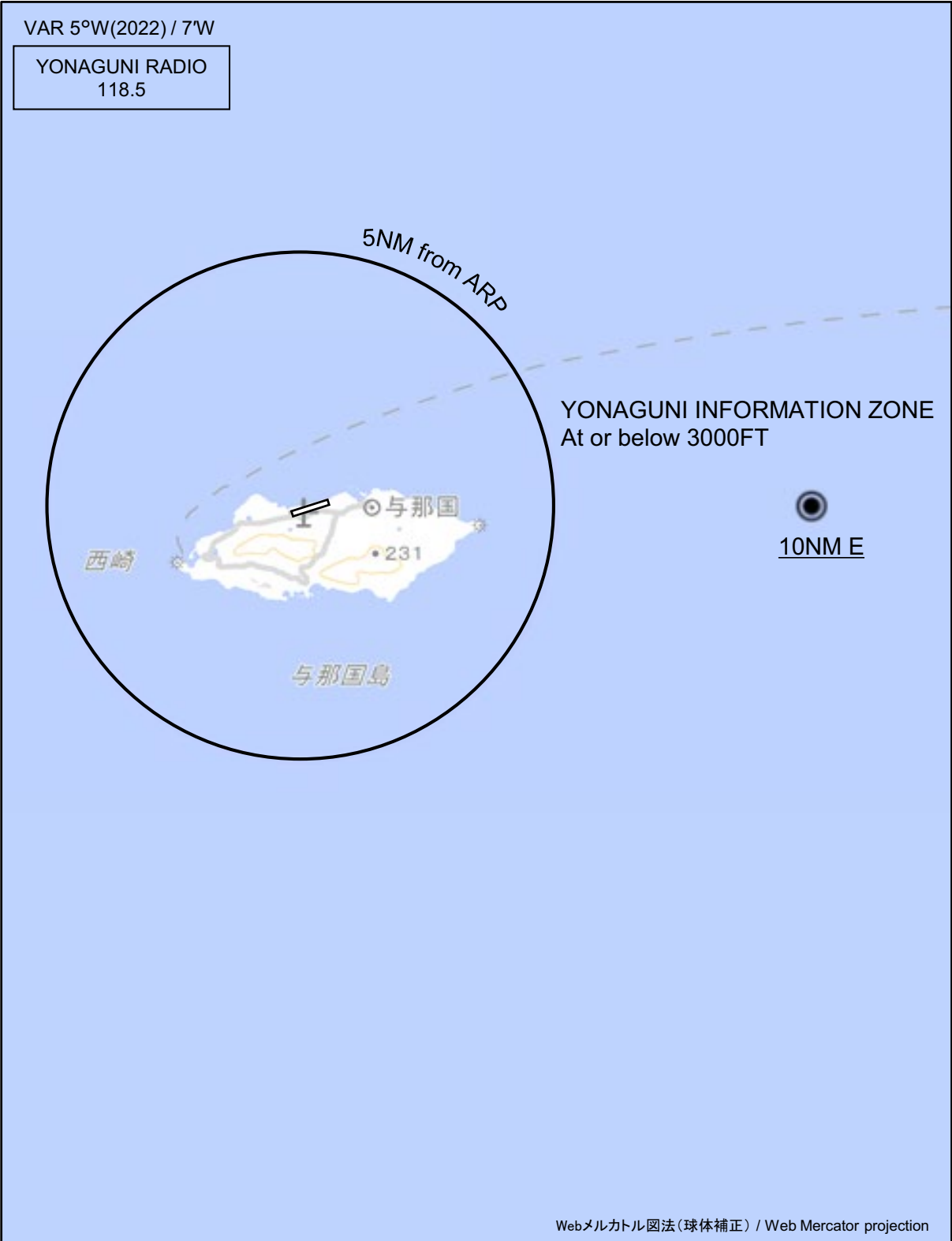

CHANGE : Map updated. BRG/DIST from ARP.

※図中に標高を示す数字がある場合、単位はメートル(m)である。The unit of measurement used to express elevation is meter(m).

Call sign	BRG / DIST from ARP	Remarks
10NM E	090°T / 10.0NM	海上 Over the sea

ROYN / YONAGUNI

Minimum Vectoring Altitude CHART

